

# AIRBEST



Vacuum Solutions Supplier

**AIRBEST**

Make Smart , Go Together



## Company Introduction

AIRBEST was established in 2006, engaged in R&D, production and sales of vacuum gripping products (vacuum generators, vacuum suction cups and vacuum grippers, etc).

Products are used in different industries, mainly including intelligent manufacturing, automotive metal stamping, packaging, woodworking, industrial robots, foods, pharmaceuticals, electronics, etc.

We pay attention to the practical application of products, quality-orientation and innovation first. So far we acquired many patents.

In 2022, AIRBEST became a brand by Piab Group. AIRBEST constantly serves customers and makes improvements, contributes our professional technology in vacuum gripping field.

Appreciate your attention and support to AIRBEST.

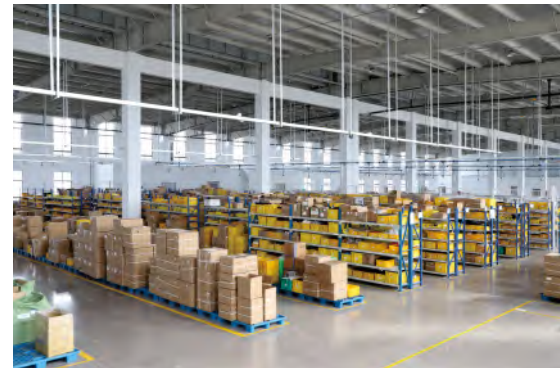

# Contents

## A Vacuum Technology

1	Vacuum Technology Introduction
6	Application Symbol
7	Product Characteristics Symbol
8	Thread Instruction
9	Connector Selection
10	PJS Series Universal Insert Fitting
12	PJF Series Locking Fitting
14	PJT Series Thread Adaptor
14	Level Compensator
17	Suction Cup + Fitting
20	Suction Cup + Level Compensator (PSPE)
21	Suction Cup + Level Compensator (PSPF)
22	Suction Cup + Level Compensator
23	Application of Vacuum Technology
24	How to use sponge suction cups

## B Vacuum Generators

25	AZK Series
34	AZQ Series
39	AZX Series
44	AZD Series
47	AGS Series
57	AGP Series
59	AGX Series
61	AGE Series
64	ABM/ABX Series
70	ABM/ABX Combined type
75	AMC Series
81	AM/AL/AH Series
90	AM/AL Combined type
95	AMDSeries
99	AZW Series
102	AZR Series
107	ABT Series
110	ABPSeries
112	ABQ Series
114	AEVC Series
117	AZL Series
121	ALH Series
124	AZH Series
130	AZU Series
133	ACV Series
138	ASBP Series
141	ALS Series
144	ACP Series
147	ACPF Series
150	ACPS Series
152	APB Series

## C Vacuum Suction Cups

155	SZ Series
163	SPH Series
169	SP3 Series
183	SUF Series
184	SAN Series
185	SAO Series
192	SOFA Series
193	STP Series
195	SFT Series
198	SFA Series
201	SBT Series
202	SBLSeries
205	SBLP Series
207	SBS Series
209	SFP Series
212	SBP Series
216	SXP Series
220	SGP Series
223	SBOF Series
226	STC Series
230	SFF Series
234	SOB Series
237	SOF Series
241	SOG Series
244	SFM Series
248	SOM Series
251	SBF Series
254	SDM Series
256	SFU Series
260	SFK Series
263	SHT Series
265	SDL Series
266	SFG Series
269	SFGT Series
271	SFD Series
273	SB Series
278	SBA Series
283	SF Series
289	SU Series
293	SP2F Series
300	SPA Series
309	SPD Series
311	SPF Series
323	SPC Series
329	SPJ Series
338	SPU Series
341	SH Series
348	SHB Series
355	SBB Series
357	SOP Series
359	SNP Series

## D Special Vacuum Grippers

361	SLG Series
364	SNC Series
366	SNT Series
368	SLP Series
371	SLB Series
375	SLW Series

## E Vacuum Grippers

377	TXN Series
385	TXD Series
388	TXC Series
393	TXM Series
397	TXP Series
399	TXH Series
403	TXL Series

## F Mounting Parts

407	PSPE Series
411	PSPL Series
413	PSPS Series
416	PSPT Series
420	PSPH Series
423	PSPD Series
426	PSPF Series
429	PJS Series
433	PJT Series
435	PJF Series
437	PJB Series
438	PJE Series
439	PJH Series

## G Vacuum Accessories

441	ZFS Series
443	ZFA Series
446	ZFD Series
447	ZFB Series
449	ZFL Series
450	ZFP Series
452	ZVAB Series
453	ZVAC Series
454	ZVEA Series
455	ZVR Series
457	ZVRM Series
459	ZVCM Series
460	ZVD Series
461	ZVS Series
463	ZPDT Series
467	ZPDE Series
471	ZPMR Series
472	ZSA Series



**A** Vacuum Technology

## Vacuum level

The difference between standard atmospheric pressure and absolute pressure.

## Pressure unit

Positive pressure conversion table

	Pa(N/m <sup>2</sup> )	kPa	bar	kg/cm <sup>2</sup>	torr	psi(ibf/in <sup>2</sup> )	inHg
<b>1 Pa</b>	1	0.001	0.00001	10.1792×10 <sup>-6</sup>	7.50062×10 <sup>-3</sup>	0.145038×10 <sup>-3</sup>	0.3×10 <sup>-3</sup>
<b>1 kPa</b>	1,000	1	0.01	10.1792×10 <sup>-3</sup>	7.50062	0.145038	0.3
<b>1 bar</b>	100,000	100	1	1.01972	750.062	14.5038	30
<b>1 kg/cm<sup>2</sup></b>	98,066.5	98.0665	0.980665	1	735.559	14.2233	29.42
<b>1 torr</b>	133.322	0.133322	1.33322×10 <sup>-3</sup>	1.35951×10 <sup>-3</sup>	1	19.3368×10 <sup>-3</sup>	0.04
<b>1 psi</b>	6,894.76	6.89476	68.9476×10 <sup>-3</sup>	70.3096×10 <sup>-3</sup>	51.7149	1	2.07

Negative pressure conversion table

	mbar	kPa	-kPa	%vacuum	torr	-mmHg	-inHg
<b>Atmospheric pressure</b>	1,013	101.3	0	0	760	0	0
	913	91.3	10	9.9	685	75	3
	813	81.3	20	19.7	610	150	6
	713	71.3	30	29.6	535	225	9
	613	61.3	40	39.5	460	300	12
	513	51.3	50	49.3	385	375	15
	413	41.3	60	59.2	310	450	18
	313	31.3	70	69.1	235	525	21
	213	21.3	80	79	160	600	24
	113	11.3	90	89	85	675	27
<b>Absolute vacuum</b>	0	0	101.3	100	0	760	30

## Flow

Air volume flows through specified cross section per unit time

Flow conversion table

	m <sup>3</sup> /s	m <sup>3</sup> /h	NL/min	NL/s	ft <sup>3</sup> /min(scfm)
<b>1 m<sup>3</sup>/s</b>	1	3,600	60,000	1,000	2,118.9
<b>1 m<sup>3</sup>/h</b>	0.28×10 <sup>-3</sup>	1	16.6667	0.2778	0.5885
<b>1 NL/min</b>	16.67×10 <sup>-6</sup>	0.06	1	0.0167	0.035
<b>1 NL/s</b>	1×10 <sup>-3</sup>	3.6	60	1	2.1189
<b>1 ft<sup>3</sup>/min</b>	0.472×10 <sup>-3</sup>	1.6992	28.32	0.4720	1

## How to produce vacuum

Compressed air flows in high speed, which sucks the air in vacuum chamber, then vacuum chamber has negative pressure

## Instructions for suction cups' applications

We separated applications in vacuum applied to sealed and unsealed systems. Sealed systems are all applications where there is no leakage between the suction cup and the substrate

Examples: Handling of glass plates / handling of smooth surface metal plates / Evacuation of containers / Tests of tightness

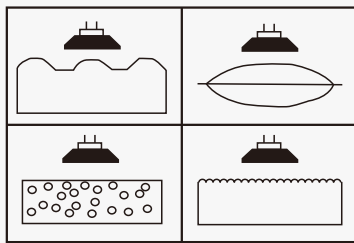

Figure 1.1 types of surface

Unsealed systems applications are that where there is leaking through the suction cup and the substrate, where the product is porous, or through the edge of the pad in the case of rough substrates. There is the possibility of applications where leakage occurs by both ways

Examples: Handling of cardboard box / Handling of foam / Handling of rough ceramic floor

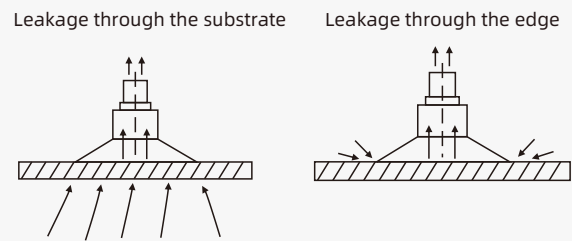

Figure 1.2 Unsealed system

## Types of suction cups

### Flat suction cups

- Small course of work, suitable for fast gripping
- Good for handling flat objects
- Suitable for horizontal or vertical loads and flip over

### 1.5 Bellows suction cups

- Good for handling objects with uneven surface and curved objects
- Large course of work, compensate for varying workpiece heights
- Suitable for horizontal or vertical loads, slightly flip over

### Multiple bellows suction cups

- Large course of work, compensate for varying workpiece heights
- Good for handling objects with uneven surface and curved objects
- Limited load capacity, not suitable for fast gripping and flip over

We recommend the ideal vacuum level for suction cups working is -60kPa~-80kPa, because the energy consumption ratio is greatly reduced when the vacuum level beyond -80kPa

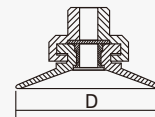

Figure 1.3 Flat suction cups

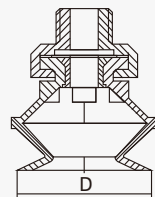

Figure 1.4 1.5 Bellows suction cups



Figure 1.5 Multiple bellows suction cups

## Suction force

Suction force means the maximum weight of the object, which can be gripped in vertical lifting; it is proportional to the pressure difference and effective suction area

Calculation formula of suction force:  $F = P \times S$

$F$  = Suction force

$P$  = Vacuum level, the difference between atmospheric pressure and internal pressure of suction cups.

$S$  = Effective suction area

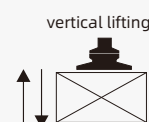

Figure 1.6 Movement

## Lateral force

Lateral force means the maximum weight of the object, which can be gripped in lateral lifting; it is related to suction force of suction cups and friction

Calculation formula of lateral force:  $F_L = P \times S \times \mu$   
 $\mu =$  Friction coefficient

Friction coefficient “ $\mu$ ” is the ratio of friction and suction force between the suction cups and workpiece, the inner structure of suction cups and surface of workpiece has influence on the friction coefficient. For the same type surface of workpiece, the friction coefficient of suction cups with inner support is larger than the flat suction cups; for the same suction cup, the friction coefficient of workpiece with dry and rough surface is larger than the smooth surface workpiece

Table 1.1 Friction coefficient (reference)

Surface of workpiece	Friction coefficient $\mu$
Wet or oily surface	0.1~0.4
Smooth and flat surface (glass, slate, plastic, metal)	0.5
Rough and flat surface (dry)	1

## Safety factor

The suction force or lateral force is theoretical value, many other important factors should be considered in practical application, such as the size and shape of suction cups, smoothness, hardness and shape of workpiece, handling speed, flip over, etc. The safety factor k should be considered when choose the model of suction cups,  $k \geq 2$

Table 1.2 Safety factor (reference)

Type of workpiece or working type	Safety factor k
Smooth and flat workpiece	2
Smooth and flat workpiece with fast movement or flip over	4
Rough or irregular workpiece	4
Carton packages	4
Softbag packages	6

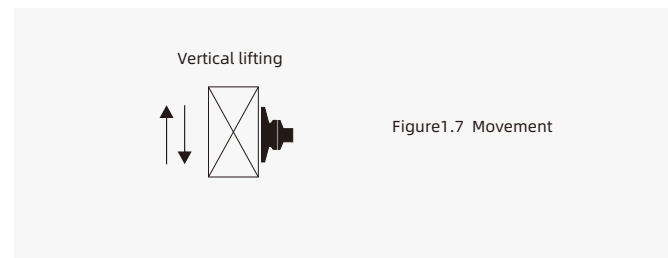

## Selection of diameter of the suction cup

According the formulas, we could calculate the approximate diameter of suction cups

Table1.3 Formulas for diameter for different type of suction cup

D=diameter of suction cup (mm) V=vacuum level (-kPa)  
 k=safety factor (refer to table 1.2) m=weight of workpiece (kg)  
 n=number of suction cups in the application

Type of suction cups	Formula	Type of suction cups	Formula
1.5 bellow type 	$D = 152 \times \sqrt{\frac{m \times k}{V \times n}}$	Multiple bellows 	$D = (223.5 \sim 558.5) \times \sqrt{\frac{m \times k}{V \times n}}$
Flat type 	$D = 139.5 \times \sqrt{\frac{m \times k}{V \times n}}$	Theoretical (without deformation)	$D = 117 \times \sqrt{\frac{m \times k}{V \times n}}$

## Example

### Sealed system

Determine the type and number of suction cups for handling an aluminum plate, with smooth and flat surface, size 2000x2000mm, weight 260kg. The manipulation will be done through a pulley in the horizontal direction at low speed

The handling surface is nearly smooth and flat  
Safety factor is 2

To ensure the stability of handling and avoid the deformation and bending of aluminum plate under gravity, we use 8pcs suction cups and calculate the result in case of vacuum level -60kPa

From Table 1.3, we could conclude that:

$$m=260\text{kg} \quad k=2 \quad V=-60\text{kPa} \quad n=8$$

$$D=139.5 \times \sqrt{\frac{m \times k}{V \times n}} \Rightarrow D=139.5 \times \sqrt{\frac{260 \times 2}{60 \times 8}} = 145.19\text{mm} \approx \boxed{150\text{mm}}$$

According to the result, we could choose AIRBEST flat suction cup SPF150 or SF150

## Layout of hoses

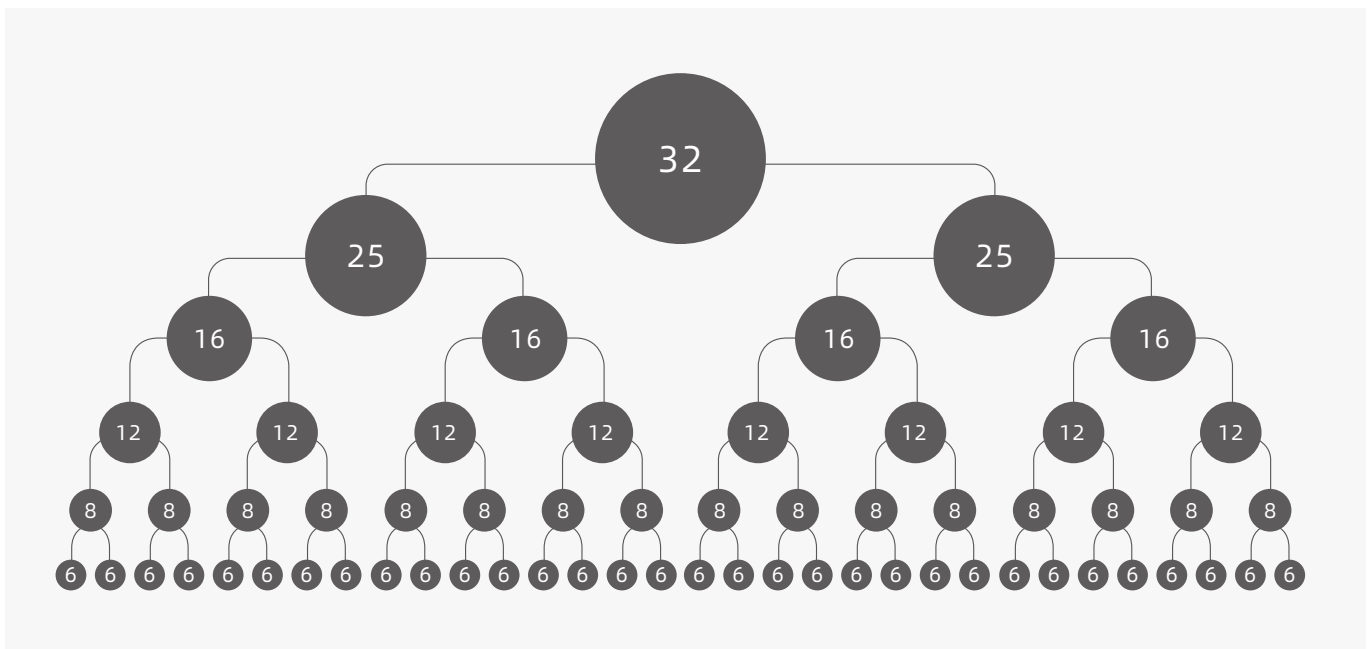

Common application (for reference):

- ◇ The diameter mentioned above, for hoses dia. ≤ 16mm means outer diameter; dia. > 16mm, means inner diameter
- ◇ The hoses layout above is for reference only, please consider the actual application

### Material characteristic

Material	Short time contact temperature(°C) ≤ 30s	Long time contact temperature(°C) > 30s	Wear resistance	Oil resistance	Weather and ozone	Resistivity
<b>N</b> - NBR	- 20 ~ +110	- 10 ~ +80	◎	◎	○	-
<b>S</b> - Silicone	- 40 ~ +250	- 30 ~ +200	×	×	◎	-
<b>CN</b> - Conductive NBR	- 10 ~ +100	- 10 ~ +70	◎	◎	○	10 <sup>5</sup> -10 <sup>9</sup>
<b>CS</b> - Conductive silicone	- 30 ~ +200	- 20 ~ +160	×	×	○	10 <sup>5</sup> -10 <sup>9</sup>
<b>U</b> - Polyurethane	+10 ~ +60	+10 ~ +40	◎	◎	◎	-
<b>HK</b> - Extra high temp rubber	- 10 ~ +350	- 5 ~ +250	◎	○	○	-
<b>E</b> - EPDM	- 30 ~ +150	- 20 ~ +120	○	×	◎	-
<b>HS</b> - High temp silicone	- 20 ~ +300	- 10 ~ +250	△	×	◎	-
<b>HD</b> - High temp/mark free material	- 10 ~ +180	- 5 ~ +160	◎	◎	◎	-
<b>NR</b> - Natural rubber	- 20 ~ +80	- 10 ~ +60	◎	×	△	-
<b>NF</b> - Neoprene foam rubber	- 20 ~ +80	- 10 ~ +60	◎	△	◎	-
<b>OF</b> - Geranium foam rubber	- 20 ~ +80	- 10 ~ +60	◎	×	×	-

◎: Excellent ○: Good △: Fair ×: Unsuitable

### Suction cups storage instruction

**Temperature**

The suitable temperature for suction cups storage is 15°C~25°C (59°F~77°F)

**Humidity**

The relative humidity of storage environment should be less than 65% and without condensation, avoid extremely wet or dry storage environment

**Lights**

Please store in dark environment, avoid direct sunlight or strong UV

**Radiation**

Keep away from ionizing radiation

**Ozone**

Ozone will cause harm to the products

**Deformation**

The products should be stored in a loose space to avoid being squeezed

**Stock turnover**

Follow "First In First Out" for the stocks

### Color and hardness of suction cup

**Examples**

<b>S</b> - Silicone		Color is red, calibration hardness is 50°
<b>WS</b> - White silicone		Color is white, calibration hardness is 50°
<b>CS</b> - Conductive silicone		Color is black, there is red dot on surface ,calibration hardness is 55°

Suction cup's color, hardness are shown as above icon for your reference. Besides, slight color difference caused by catalogue printing and difference between calibration hardness of material and actual hardness of suction cup are normal. (Generally within ±5°)

UI	Industry	Description	Recommendation		Applicable Suction cups
			Vacuum generator	Suction cup	
	PACKAGING (Carton)	Mainly for handling, logistics, stacking, storage of carton and soon. The features are that the workpiece is easy to deform, porous, medium weight, various sizes, and has high requirement for wear resistance of the suction cup	Vacuum gripper, multi stage vacuum pump, etc take advantage of flow to compensate leakage loss	NBR, PU, etc. Excellent wear resistance, recommend bellows suction cups	TXC, TXM SB, SPC
	PACKAGING (Plastic Bag)	Mainly for gripping, destacking, handling of plastic bag, purchasing bag, cat food bag and dog food bag. The features are that the workpiece can be both soft and hard and has wrinkles, and has high requirement for deformation and adaptability of suction cup itself	Select vacuum generator according to weight and characteristic of workpiece	Silicone, soft and flexible, recommend multiple bellows suction cups	SBL, SBLP STP, SPJ SFA
	GLASS	Mainly for handling, gripping of universal glass, industry glass, float glass and so on. The features are that workpiece is heavy, flat, smooth, hard and it has requirement of powerful lateral gripping force	Select vacuum generator according to weight and characteristic of workpiece	NBR, excellent wear resistance, recommend flat suction cups	SFG, SF
	METAL SHEET (Sheet Metal)	Metal sheet industry, mainly for handling, fixing and processing of metal plate. The features are that the workpiece is easy to deform, with oily surface, curved metal plate, heavy weight and has high requirement for big internal support, anti slip, anti deformation of suction cup	Select vacuum generator according to weight and characteristic of workpiece	NBR, PU etc. excellent wear resistance, recommend flat or 1.5 bellows suction cups	SFF, SFM STC, SBF SOF, SOB SDM, SOM
	META SHEET (Thick Metal Plate)	Metal sheet industry, mainly for handling, fixing and processing of metal plate. The features are that the workpiece is, with oily surface, heavy weight and has high requirement for large internal support, slip resistance, anti deformation of suction cup	Select vacuum generator according to weight and characteristic of workpiece	NBR, PU, etc. excellent wear resistance, recommend flat suction cups	SFF, SFM SDM, SOF SFK
	AUTOMOTIVE	Automotive industry, mainly for glass, curved metal plate, tyre and so on. The features are that metal plate is with uneven and curved surface, glass is smooth and with heavy weight, and has high requirement for slip resistance	Select vacuum generator according to weight and characteristic of workpiece	NBR, PU etc. excellent wear resistance and good oil resistance	SBF, SFG SFF, SFM STC, SBF SOF, SOB
	WOOD	Wood industry, mainly for handling of wood plate, fiberboard, wooden handicraft and so on. The features are uneven surface, porous, heavy weight, good sealness and large internal support for suction cup	Multistage vacuum generator AM/AL, etc. Take advantage of flow to compensate the flow loss between suction cup and workpiece	NBR, excellent wear resistance	SF, SPF SFU, SFD SOM
	FABRIC	Fabric industry, mainly for handling of cloth, gauze and so on. The features are workpiece is easy to deform, porous, light weight, overlap, and has requirement of large vacuum flow for suction cup	Select vacuum generator according to weight and characteristic of workpiece	POM material special gripper, which is with suction cup, recommend flow gripper	SLP, SLB
	COMPOSITE MATERIAL	Mainly for handling leather, fiber plate, the features are that the workpieces are porous, light, and overlapping and has requirement of large vacuum flow for suction cup	Select vacuum generator according to weight and characteristic of workpiece	Select suction cup according to actual condition	SLB
	STONE	Stone industry, mainly for handling marble, bricks, and so on. The features are that workpiece is with uneven surface and has requirement for large deformation of suction cup	Multistage vacuum generator AM/AL, etc. Take advantage of flow to compensate the flow loss between suction cup and workpiece	NF-Neoprene foam rubber OF-Geranium foam rubber large deformation and good tightness, recommend foam rubber suction cup	SOP, SNP
	INJECTION MOLDING	Plastic industry, mainly for handling in latter procedure of plastic injection molding. The features are high temperature resistance, workpiece with curved surface, and has high requirement for high temperature	Select vacuum generator according to weight and characteristics of workpiece	Silicone, HD high temp material, recommend high temp material suction cup	Silicone, HD high temp material, other special custom-made products
	ROBOT	Robot terminal components, supporting robot to grip and handle. The features are that it requires fast response, combined type saving pipes, system with high safety factor.	Select vacuum generator according to weight and characteristics of workpiece	Select suction cup according to workpiece	--
	MACHINE	Machine terminal components, supporting intelligent manufacture equipment to grip and handle. The features are that they are small size, light weight, compact and most of them are metal products	Select vacuum generator according to weight and characteristics of workpiece	Select suction cup according to workpiece	--
	ELECTRONICS (Screen)	Handling of the screen of mobilephone, tablet PC, etc. The features are mark free, without deformation, slip resistance, small and light, etc.	Select vacuum generator according to weight and characteristics of workpiece	Flat suction cup, mark free suction cup which is HD material, halogenation, and teflon tape	SNT, SZU SZC, SZB SPC, SLP SP3, etc.
	ELECTRONICS (PCB Board)	Electronics industry, mainly for handling electronic components. The features are that workpiece is with small surface, light weight, without mark, and has high requirement for conductivity of suction cup	Select vacuum generator according to weight and characteristics of workpiece	Materials like NBR, Si or conductive NBR, Conductive Si, etc are soft, wear resistant and conductive. Recommend flat, or 1.5 bellows suction cups	SZU, SZC SZB, SAN SAO, SLB TXC, SP3, etc.
	PHARMACEUTICALS	Pharmaceuticals industry, mainly for handling of medical kits, medical devices, etc. The features are that there is alcohol, chemical reagent on the surface of workpiece, and it has high requirement for chemical resistance of suction cup	Select vacuum generator according to working environment and characteristic	Special plastic material, corrosion resistance, alcohol resistance, wear resistance, weather resistance	SBOF
	FOOD	Food industry, mainly for handling of bread, chocolate, milk, etc. The features are irregular shape of surface of workpiece, light weight, plastic bag package, and it has high requirement for material of suction cup	Select vacuum generator according to weight and characteristics of workpiece	FDA silicone, soft seal or FDA POM suction cup	SBL, SBLP SNT, SBS
	NEW ENERGY (Photovoltaic)	New energy industry, mainly for handling of solar cell, circuit board. The features are that the workpiece is porous, fragile and require soft contact and large vacuum flow and average air flow	Air flow is well distributed, smoothly gripping	Wafer gripper	SLW
	NEW ENERGY (Li Battery)	New energy li battery industry, mainly for handling of battery pack, battery. The features are corrosion resistant, explosion proof of soft package gripping, safe and reliable	Select vacuum generator according to weight and characteristics of workpiece	Suction cup with corrosion resistant material, such as EPDM, fluorine rubber	SLB, SF SB, etc.

UI	Characteristic	Description	Applicable suction cups
	Porous	Suitable for porous workpiece, main features are that vacuum generator with low vacuum level and large vacuum flow(usually use flow gripper)is through flow to compensate air permeability loss to create vacuum to grip workpiece	SLB, SLP
	Curved surface	Suitable for workpiece with curved surface or certain slope surface. Usually adopt bellows suction cups to compensate the plane.	All bellows suction cups
	Slip resistance	For workpiece with smooth surface and prevent it from side slip when grip. Generally adopt flat with ribs or flat with pattern suction cup	All flat with ribs suction cups and flat with pattern suction cups
	Rough surface	Mainly for workpiece with rough surface such as wood plate, stone. In order to prevent air leakage, usually adopt sponge suction cup to compensate the micro space to grip the workpiece	SNP, SOP
	Heavy load	For gripping workpiece with heavy load, generally adopt heavy load suction cups and mounting parts	Flat suction cup with big diameter PSPH heavy load level compensator.
	Non-rotating	Mainly for workpiece having precise positioning and direction requirement.It needs non-rotating function	Non-rotating level compensator etc.
	FDA	For workpiece requiring safety certificate in food industry of medical industry, usually adopt food grade white silicone of POM suction cups with FDA	WS material suction cup, SNT-P series
	Tube shaped object	Adopt special concave suction cups for tube shaped or stick shaped workpieces	SOG
	Long and narrow object	Adopt oval suction cups special for long and narrow workpiece	SOB, SOF
	Corrosion resistance	Adopt fluorine rubber or EPDM suction cups for requirements of corrosion resistance, (such as battery liquid, chemical environment)	F/E material suction cups
	Long life time	Adopt suction cups with special material for high weariness occasion which is longer than average life	V/U material suction cups
	Spherical objects	Adopt deep taper suction cup to grip spherical objects	SZD, SBS
	Water resistance Oil resistance	Adopt special suction cups with oil resistant material and design	SFM, SBF, STC, SFF, etc.
	Composite product	Composite product integrated with vacuum generator and suction cups, save space,easy to assemble and wide usage	SLB, SLW, SLP, SNT, SLF, etc.
	Anti-deformation	Select different suction cups for different workpieces and conditions to grip workpiece without deformation	SF, SFF, SFT, SFA, etc.
	Temperature resistance up to 180°C	Adopt suction cups with high temperature resistant material for gripping workpiece with high temperature 180°C	HD suction cup, Silicone suction cup
	Temperature resistance up to 400°C	Gripping workpiece with high temperature 400°C	SHT

M5 M

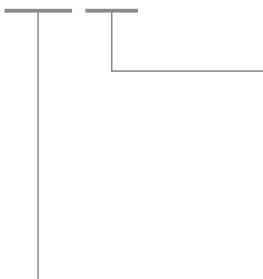

**Thread**

<b>M</b>	Male thread
<b>F</b>	Female thread

**Types of thread**

<b>M</b>	Metric thread
<b>G</b>	British standard pipe thread
<b>T</b>	NPT thread
<b>N</b>	NPSF thread
<b>R</b>	British conical pipe thread

**Example**

Types of thread	Size	
<b>M</b>	5	<b>M5:</b> M5
<b>G</b>	1	<b>G1:</b> G1/8
<b>T</b>	4	<b>T4:</b> NPT1/2
<b>N</b>	8	<b>N8:</b> NPSF1"
<b>R</b>	12	<b>R12:</b> R1"1/2
...	...	

**Connection thread instruction**

<b>G1M</b>	G1/8 Male thread	<b>G6F</b>	G3/4 Female thread
<b>G2M</b>	G1/4 Male thread	<b>G8F</b>	G1" Female thread
<b>G3M</b>	G3/8 Male thread	<b>G12F</b>	G1"1/2 Female thread
<b>G4F</b>	G1/2 Female thread		

Note: Thread pitch which is not indicated in the catalogue, is considered as national standard coarse thread specification.

P J S - \*\*\*

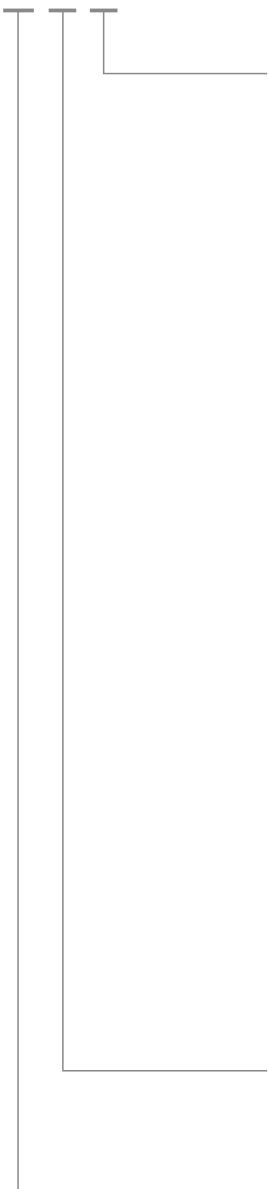

### Categories of connector

<b>S</b>	Universal inserted fitting for suction cup
<b>T</b>	Adapter
<b>F</b>	Locking fitting
<b>B</b>	Ball joint
<b>H</b>	Universal holder
<b>E</b>	Flexible joint
<b>P</b>	One-touch fitting
<b>Q</b>	Pagoda fitting

### Product code for connector

<b>J</b>	Connector
----------	-----------

### Product code for mounting parts

<b>P</b>	Mounting parts
----------	----------------





## Mounting Parts for Universal Suction Cup -Locking Fitting Selection Instruction

Series	Size range	Suction cup connection				
		M5F	M8F	G1F	G2F	G3F
SB	5-15	●				
	17-40			●		
	50				●	●
	75				●	
SBA	11-25	●				
	33-78				●	
SBF	All sizes				●	●
SBOF	All sizes				●	
SFT	15-24	●		●		
	30-40				●	
SBL	15	●				
	20-40			●		
	50				●	●
SBLP	30				●	
	40					●
SF	15	●				
	20-40			●		
	50				●	●
SU	2-8	●				
	20-40			●		
	50				●	●
SUF	All sizes	●				
STC	All sizes				●	
SFF	All sizes				●	
SFM	50-120				●	
SOB	All sizes				●	
SOF	All sizes				●	
SOG	15×40	●				
	35×100				●	
SFP	All sizes			●		
SBP	10-15	●				
	20-40			●		
	50				●	●
	70					●
SXP	20-40			●		
	50				●	●
	70					●

## Mounting Parts for Universal Suction Cup -Locking Fitting Selection Instruction

Series	Size range	Suction cup connection				
		M5F	M8F	G1F	G2F	G3F
SGP	25-45			●		
	55				●	●
SAN	All sizes	●				
SAO	All sizes					
SPA	10-20	●				
	30B	●				
	25-50		●			
SPC	5-7	●				
	10-20	●				
	30-60					
	90					
SPF	2-3.5					
	5-8	●				
	10-15	●				
	20	●				
	25-40	●				
	50					
	60-95					
	120-300					
SPJ	4					
	6-8	●				
	10-15	●				
	20-25	●				
	30-40	●				
	50					
	60-80					

## Adapter Selection Instruction

Thread(1)	Thread(2)											
	M5F	M5M	M8F	M8M	G1F	G1M	G2F	G2M	G3F	G3M	G4F	G4M
M5F	●											
M5M		●	●	●								
M8F		●	●									
M8M				●	●	●						
G1F				●	●							
G1M						●	●	●				
G2F						●	●					
G2M								●	●	●		
G3F								●	●			
G3M										●	●	●

Example: PJT-M5M-M8F

◇ Note: For detailed sizes of adapter, please refer to PJT series on page 433-434

## Level compensator selection instruction

Series	Applicable industry	Description
PSPE	Electronics industry for light and small load	Small and light level compensator, port specifications are M5 male thread and SC type
PSPT	All industries	Conventional level compensator Port specification is M8, G1/8, G1/4, G3/8 male thread and G1/8, G1/4 female thread
PSPH	Metal sheet, automotive, machinery, etc. for heavy load	Heavy-duty level compensator, connection thread on suction cup side is G3/8, G1/2 male thread
PSPF	All industries, mainly used with suction cup SPA series, SPJ series, SPF series	Compact external level compensator, port specification is M5, M8 female thread, M10 male thread
PSPD	Metal sheet, automotive, machinery, glass, packaging, etc. For heavy load	Double spring heavy-duty level compensator, can balance the deformation of the workpiece and the mounting plate of the level compensator
PSPL	For light or small size load, such as electronics industry	Retraction type level compensator, thread of connection port is M5 female thread

**P SP E - I 20 L A4 M5M - M10**

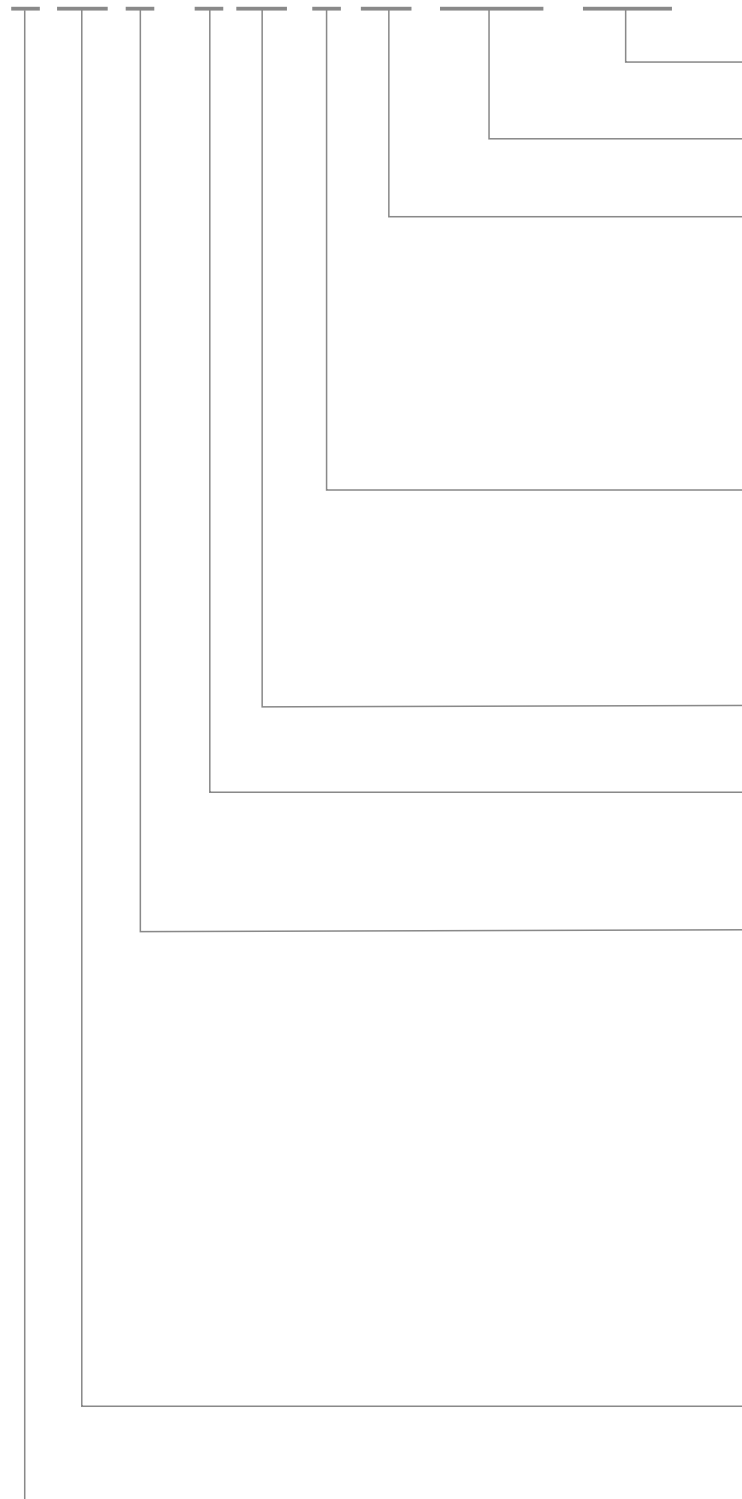

**Mounting thread**

**Suction cup connection**

**Lateral vacuum port connection**

<b>Nil</b>	Non-lateral vacuum port connection
<b>A</b>	One-touch fitting, example: A4, $\phi 4$ one-touch fitting
<b>B</b>	Pagoda fitting, example: B4, $\phi 4$ pagoda fitting
<b>M</b>	Metric thread fitting, example: M5, M5 male thread fitting
<b>R</b>	Taper pipe thread connection, example: R1, Rc 1/8 taper pipe fitting

**Rotary type**

<b>Nil</b>	Vertical rotating
<b>R</b>	Vertical non-rotating
<b>L</b>	Lateral rotating
<b>B</b>	Lateral non-rotating

**Buffer stroke**

**Buffer style**

<b>I</b>	Built-in spring
<b>E</b>	External spring

**Categories of level compensator**

<b>E</b>	Small and light level compensator
<b>T</b>	Standard level compensator
<b>H</b>	Heavy-duty level compensator
<b>F</b>	Compact level compensator with external spring
<b>D</b>	Double spring heavy-duty level compensator
<b>L</b>	Retraction type level compensator

**Product code for level compensator**

<b>SP</b>	Level compensator
-----------	-------------------

**Product code for mounting parts**

<b>P</b>	Mounting parts
----------	----------------

# Level Compensator Selection Instruction

Series	Vacuum port	Mounting connection	Buffer stroke (mm)											Vacuum port+rotary type							
			6	10	15	20	25	30	40	50	60	75	90	110	Nil Vertical rotating	R Vertical non-rotating	L Lateral rotating	B Lateral non-rotating			
PSPE	M5M	M8	●	●	●		●											●	●		
	M5M	M10		●		●		●	●	●							●	●	●	●	
	M5F	M10		●		●		●	●	●							●				
	M8M M8F	M14		●		●		●		●							●				
PSPT	M8M M8F	M14		●		●		●		●							●				
	G1/8M	M16		●		●		●		●							●		●		
	G1/8F	M16		●		●		●		●							●				
	G1/4M	M18		●		●		●		●								●	●		
											●	●	●	●				●			
	G1/4F	M18		●		●		●		●							●				
	G3/8M	M18		●		●		●		●								●	●		
											●	●	●	●			●				
PSPH	G3/8M	M30					●			●		●	●				●				
	G1/2M	M30					●			●		●	●				●				
PSPD	G1/4M	M20					●			●							●	●			
	G3/8M	M30					●			●			●				●	●			
	G1/2M	M30					●			●			●				●	●			
PSPL	M5F	M10		●	●	●											●				

Series	Vacuum port	Mounting connection	Buffer stroke (mm)					Vacuum port+rotary type		
			4	6	10	15	30	Nil Vertical rotating	L Lateral rotating	
PSPF	M5F	M11	●			●			●	●
		M14		●		●		●	●	
	M8F	M14		●		●		●	●	
	M10M	M16			●		●		●	

◇ Note: "●" - standard type, contact with sales if need customized one

## Suction cup(without fitting)+PJS series fitting for suction cup

Item	Model	Applicable suction cup
Fitting for suction cup	PJS-M5M-ST2	SPC5、7
	PJS-M5M-SPC10	SPC10
	PJS-M5M-SPC20	SPC15、18、20

◇ The above table is from page 327

Suction cup(without fitting)

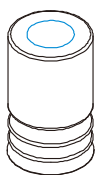

**SPC 10 N**

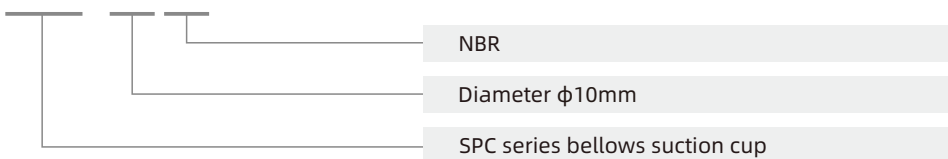

Remark: For suction cup connection, please refer to mounting parts of SPC 10

PJS series fitting for suction cup

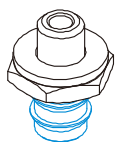

**PJS-M5M-SPC10**

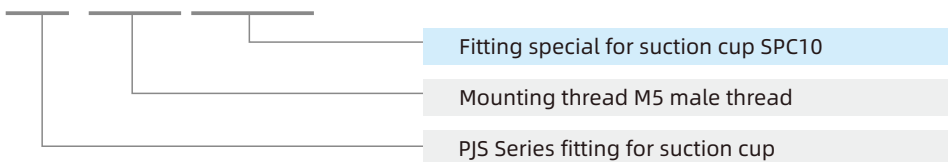

vacuum pad connection port specifications are matching

Suction cup + PJS series fitting for suction cup

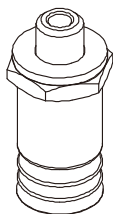

**SPC 10 N - M5M**

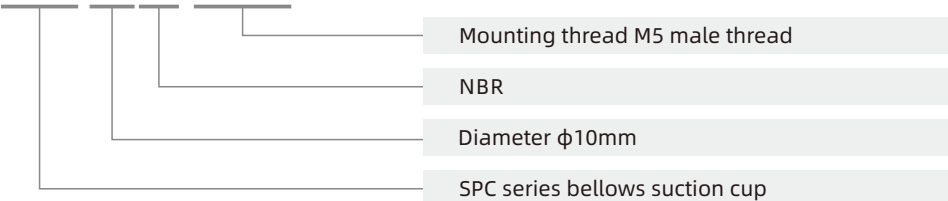

- Note:1. For description of shape of fitting for suction cup which is non-integrated vulcanized with fitting(it means that suction cup can be changed separately), please refer to PJS series fitting for suction cup on page 10-11 or parts selection of each series of suction cups. For actual dimensions of fitting, please refer to PJS series 429-432
2. All of fitting for non-integrated vulcanized suction cup can be found in instruction of each series, which is easy for customers to select model

## Suction cup(with fitting)+PJT adapter

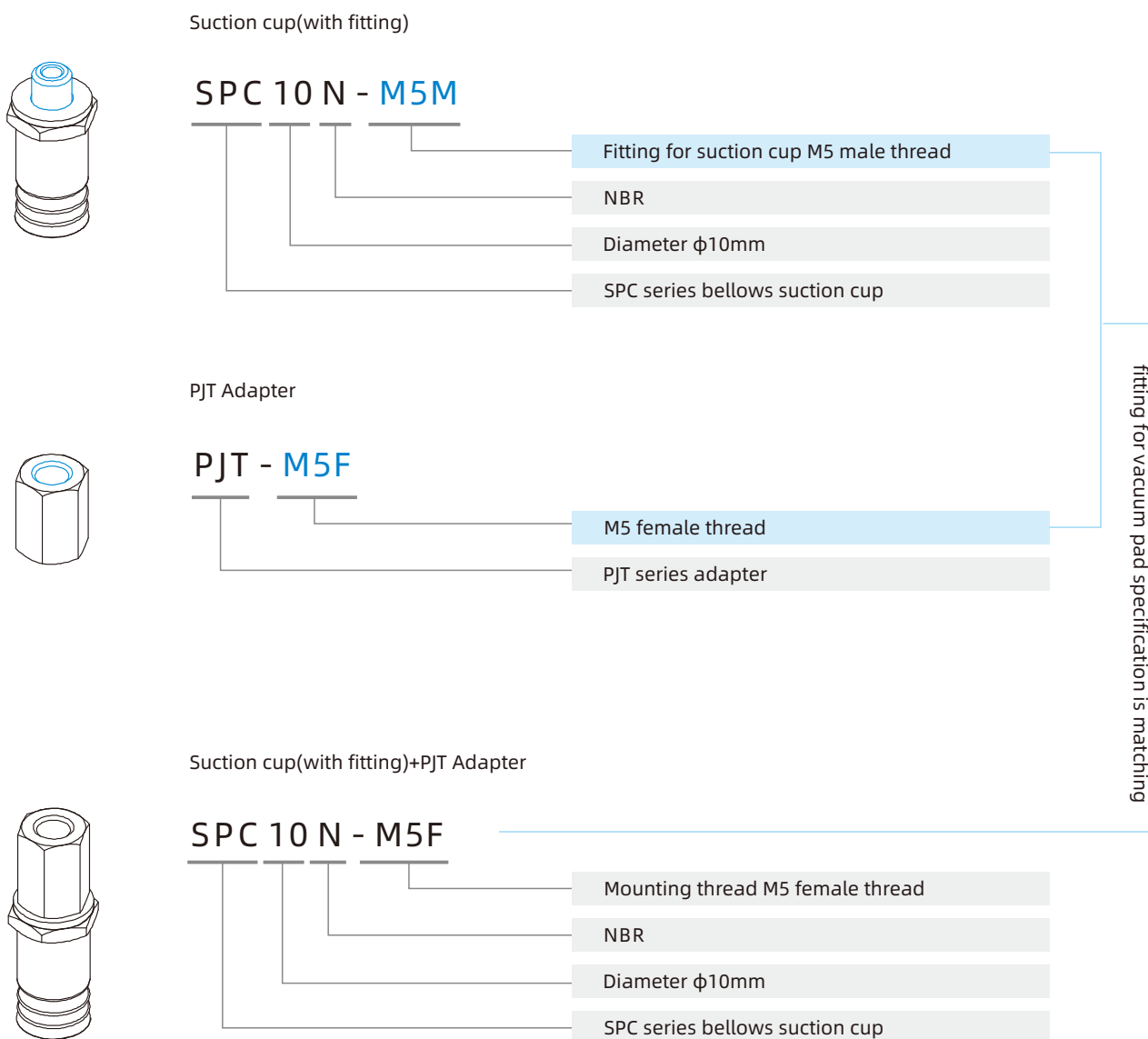

Note:1. The above example is fitting for suction cup changing from M5M to M5F  
 2. Please refer to convertible specifications of PJT adapter on page 14, and real dimensions on page 433-434

Suction cup(with fitting)+PJF locking fitting

Suction cup(with fitting)

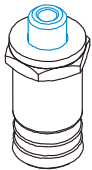

**SPC 10 N - M5M**

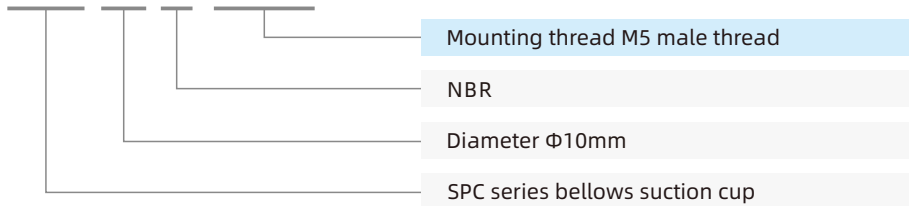

PJF Locking fitting

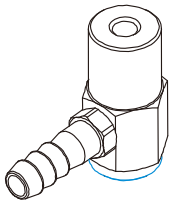

**PJF - LB6 - M4F - M5F**

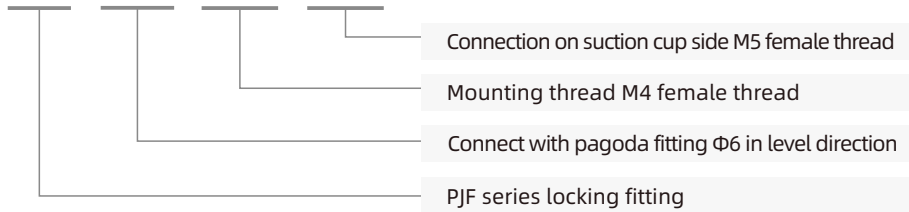

The specifications of fitting for suction cup matches

Suction cup(with fitting)+PJF Locking fitting

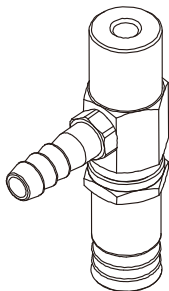

**SPC 10 N - LB6 - M4F**

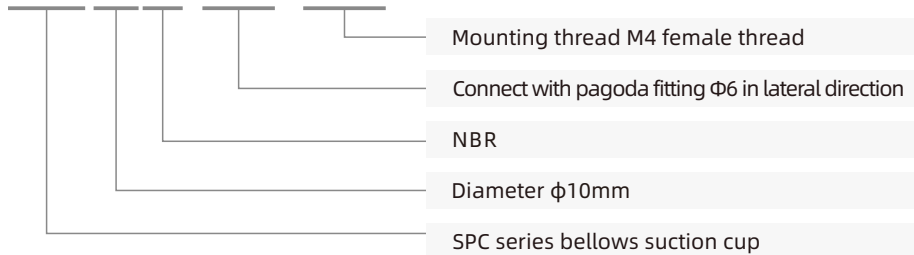

Note: 1. The above example is suction cup SPC10N with locking fitting PJF-LB6-M4F-M5F  
 2. Please refer to detailed specifications of PJF adapter on page 435-436

Suction cup(with fitting)+adapter+level compensator(standard)

model /connection	M5M
SB5 - 15	●
SB17 - 40	-
SB50	-

◇ The above table is from page 274

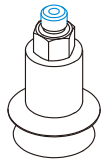

Suction cup (with fitting)

SB 15 N - M5M

- M5 male thread
- NBR
- Diameter  $\phi$ 15 mm
- SB series 1.5 bellows suction cup

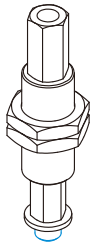

Level compensator(E type)

PSP E - I 10 R M5M - M10

- Mounting nut M10
- M5 female thread connection
- Non-rotating type
- Buffer stroke 10 mm
- Buffer style: built-in spring
- Level compensator E type
- Fixed serial number of level compensator



Adapter (PJT series)

PJT - M5F

- M5 female thread
- T series universal mounting parts-adapter

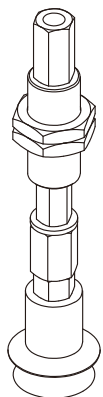

Suction cup+Adapter+Level compensator

SB 15 N - E I 10 R - M10

- Mounting nut M10
- Non-rotating
- Buffer stroke 10 mm
- Buffer style: built-in
- Level compensator E type
- NBR
- Diameter  $\phi$ 15 mm
- SB series bellows suction cup

Not match

Switch

Suction cup(with fitting)+ Level compensator



Suction cup (with fitting)

**SPC 20 N - M5M**

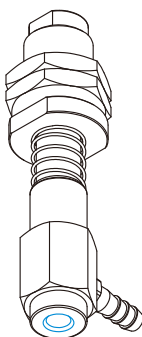
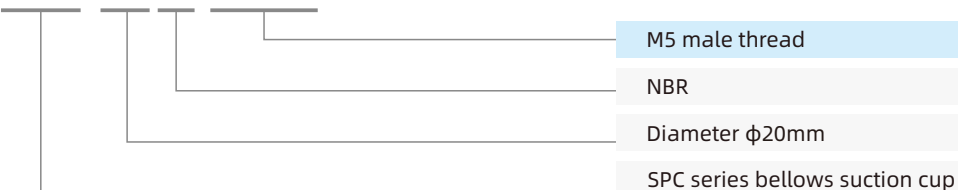

PSPF Level compensator

**PSP F - E 6 L B6 M5F - M14**

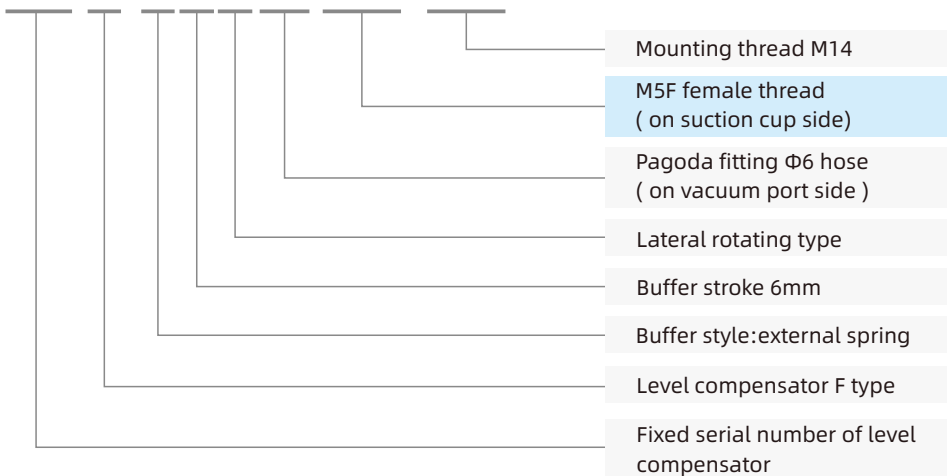

Specifications of fitting for suction cup matches

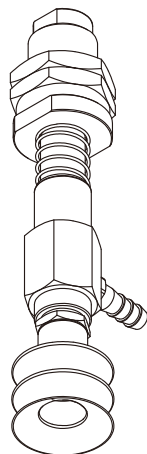

Suction cup(with fitting) +PSPF Level compensator

**SPC 20 N - F E 6 L B6 - M14**

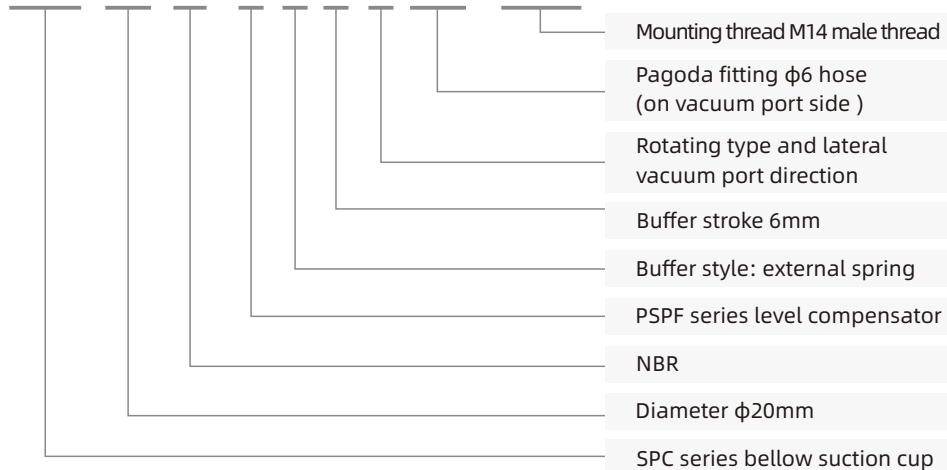

Note: 1. The above example is suction cup SPC20N-M5M with level compensator PSPF-E6LB6M5F-M14  
 2. Please refer to PSPF level compensator on page 426-428

# Selection Instruction for Suction Cup +Level Compensator

Recommend applicable level compensators according to suction cups



Series	Size range	Recommend level compensator (AIRBEST standard)				
		PSPE	PSPT	PSPH	PSPF	PSPD
SB	5-15	●				
	17-75		●			
	110-150			●		
SBA	11-25	●				
	33-78		●			
SBB	All sizes			●		●
SBF	All sizes		●			
SBOF	All sizes		●			
SFT	15-24	●	●			
	30-40		●			
SFA	All sizes	●				
STP	All sizes		●			
SBL	15	●				
	20-50		●			
SBLP	30		●			
	40-50 *					
SF	15	●				
	20-75		●			
	110-200			●		●
	300*					
SU	2-8	●				
	20-80		●			
SUF	All sizes	●				
SFG	All sizes			●		●
SFU	All sizes			●		●
STC	All sizes		●			
SFF	All sizes		●			
SFM	All sizes		●			
SDM	All sizes		●			
SHT	All sizes		●			
SOB	All sizes		●			
SOF	All sizes		●			
SOG	15x40	●				
	35x100		●			
SFP	All sizes		●			

Series	Size range	Recommend level compensator (AIRBEST standard)			
		PSPE	PSPT	PSPH	PSPF
SBP	10-15	●			
	20-70		●		
SXP	All sizes		●		
SGP	All sizes		●		
SDL	All sizes		●		
SZD	10-25	●			
	40	●	●		
SH	All sizes		●		
SHB	All sizes		●		
SZC	10-32	●			
	40-50	●	●		
SZU	2-32	●			
	40-50	●	●		
SZB	6-32	●			
	40-50	●	●		
SAN	All sizes	●			
SAO	All sizes	●			
SPA	All sizes				●
SPC	5-60				●
	90		●		
SPF	2-95				●
	120-200*				
SPJ	4-50				●
	60-80		●		●
SPU	10-50				●
	60-100		●		
SNP	50-75		●		
	68		●	●	
	140			●	
SOP	40-64		●		
	92		●	●	
	127-220			●	

Note:1. "●" means that selected suction cup directly matches the recommended level compensator  
 2. "\*" means that there is no level compensator directly for this item

---

## Working Environment

### Warning

1. Protection measures must be provided to ensure safety, if there is risk of falling
2. Because the connector of the vacuum device is not explosion-proof, the pressure in vacuum pipe which is 0.1MPa or more for a long time is not safe, please note
3. When there are two pieces or more suction cups connected to one vacuum generator, the workpiece may fall off if one of the suction cups failure
4. Do not use the products in the environment with corrosive gas, flammable gas, explosive gas, chemicals, seawater or steam, which are not allowed enter into the vacuum system
5. Don't block the ports of vacuum generators or increase the exhaust resistance, will otherwise it cause flow loss or vacuum reduction
6. Protective cover should be added when the equipment is exposed in sunlight directly
7. Avoid using the equipment in environment of excessive vibration, which may cause failure

## Design/Setting

### Note

1. Please pay attention to the vacuum level drop, it may be caused by the unstable air supply or power supply failure, and the workpiece may fall. Protective measures must be made
2. Check the mark of each port on vacuum generator, wrong connection to the vacuum system will damage the equipments
3. The supplied air to vacuum generator should be clean, and lubricant should not be used in the supplied air. Impurities or oil in compressed air will cause failure and reduce the performance
4. If there is leakage from workpiece or pipes, the vacuum flow will not be enough to hold the workpiece. If the connection pipe is too long or thick, the action time will be longer as the volume of pipe is increased
5. The effective sectional area of pipe for vacuum port should be selected according to the maximum vacuum flow of the vacuum generator. The effective sectional area of pipe for air supply port should be selected according to the maximum air consumption of the vacuum generator
6. The max. vacuum level, max. vacuum flow and air consumption are the values at the rated air supply pressure and under the test conditions. The values may differ to the weather, altitude as well as the test methods
7. Noise level is the value under the test conditions, but not a guaranteed value
8. Evacuation time is the time for evacuating 1L measuring vessel

---

## Maintenance

### Warning

1. Elements of silencer and filter elements should be maintained and examined regularly. Block in elements will reduce the performance or cause products damage
2. Need to study the components of vacuum generator before replacement.
3. Do not wash or spray equipment with water or solvents
4. In vacuum system, do not use lubricator in the front pipe of vacuum generator, dirties will be blocked in the nozzle and affect the performance of vacuum generator
5. Do not use PTFE tape for connection use (especially the fittings), this tape would fall off easily and block the pipe, affecting the performance of vacuum generator

---

## Installation

### Warning

1. Don't block the ports of vacuum generators or increase the exhaust resistance, otherwise it will cause flow loss or vacuum reduction
2. Do not remove the shell, the shell will be damaged or leaking if it's forced to shake or rotate
3. Do not use the equipment in the flammable or explosive environment, which may cause fire or explosion

## How to use sponge suction cups

Sponge suction cup is a foamed rubber suction cup with fluffy structure and low porous density. Compared to other material, the tension of foam material itself is insufficient and it cannot be used as a buffer zone by its own deformation.

Therefore, when setting the compression stroke of the sponge suction cup, it needs to be closer to the suction cup itself and try to avoid pulling the sponge outward (internal compression does not affect the performance of the sponge). If there is a pulling trend, it will affect the service life of the sponge suction cup, and attention should be paid when using it. When using a sponge suction cup, ensure that the sponge is compressed to the root, generate a vacuum and ensure that the workpiece can be lifted after the vacuum is achieved.

Otherwise, relying on the sponge's own tension to extract the workpiece will cause the sponge to tear and the product to fail.

## Recommended setting of workpiece distance for sponge suction cups, case description.

Sponge suction cups should be pressed to the root.

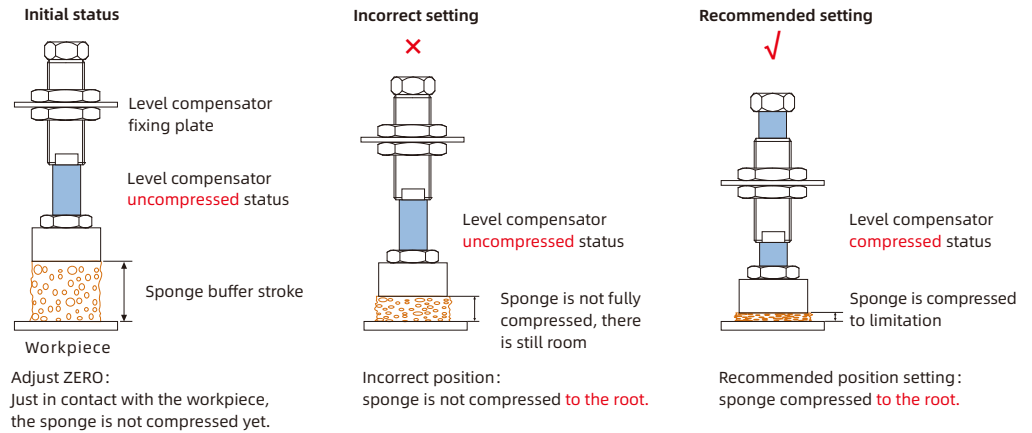

## Incorrect settings can damage the sponge

Incorrect setting may cause tearing and failure of sponge suction cups, reducing product life.

Incorrect setting, vacuum instruct issued under this status

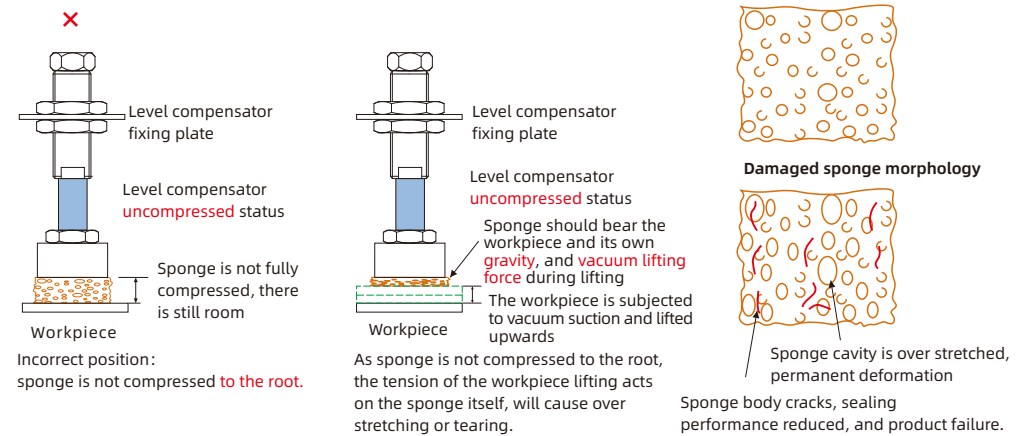

## Recommended usage of sponge suction cups

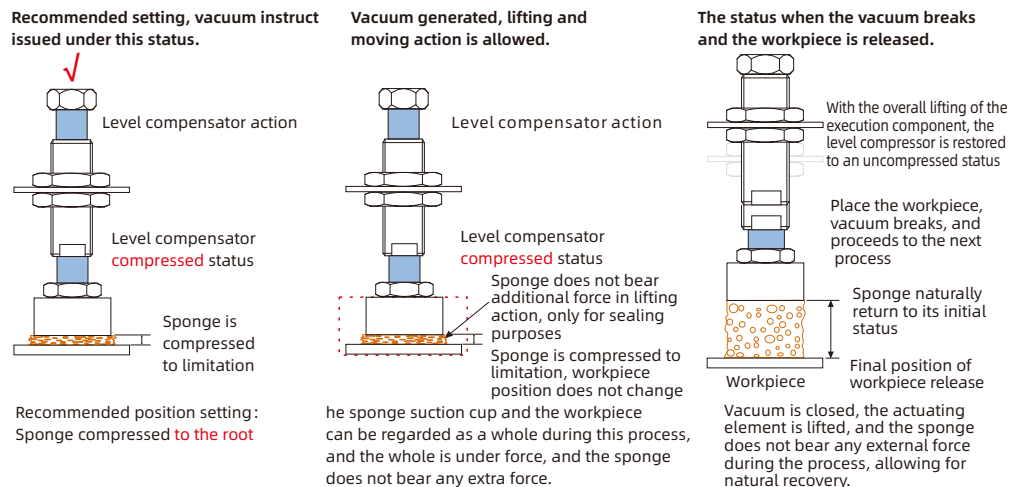



**B** Vacuum Generators

# Vacuum Generators Series



## Products overview

### Vacuum Generators

#### 25 AZK Series

##### Integrated Vacuum Generator

- ◇ Max.vacuum level: -91kPa
- ◇ Max.vacuum flow: 68NL/min



ELECTRONICS PACKAGING PLASTIC



RoHS

#### 57 AGP Series

##### Multistage Vacuum Generator

- ◇ Max.vacuum level: -93kPa
- ◇ Max.vacuum flow: 68NL/min



ELECTRONICS PACKAGING METAL SHEET



RoHS

#### 34 AZQ Series

##### Mini Integrated Vacuum Generator

- ◇ Max.vacuum level: -91kPa
- ◇ Max.vacuum flow: 35NL/min



ELECTRONICS PACKAGING PLASTIC



RoHS

#### 59 AGX Series

##### Multistage Vacuum Generator

- ◇ Max.vacuum level: -95kPa
- ◇ Max.vacuum flow: 390NL/min



ELECTRONICS PACKAGING METAL SHEET



RoHS

#### 39 AZX Series

##### Large flow Integrated Vacuum Generator

- ◇ Max.vacuum level: -85kPa
- ◇ Max.vacuum flow: 220NL/min



ELECTRONICS PACKAGING PLASTIC



RoHS

#### 61 AGE Series

##### Mechanical Energy-saving Vacuum Generator

- ◇ Max.vacuum level: -92kPa
- ◇ Max.vacuum flow: 41NL/min



GLASS METAL SHEET



RoHS

#### 44 AZD Series

##### Energy-saving Vacuum Generator

- ◇ Max.vacuum level: -83kPa
- ◇ Max.vacuum flow: 90NL/min



UNIVERSAL



RoHS

#### 64 ABM/ABX Series

##### Mini Vacuum Generator

- ◇ Max.vacuum level: -92kPa
- ◇ Max.vacuum flow: 220NL/min



METAL SHEET PACKAGING PLASTIC



RoHS

#### 47 AGS Series

##### Multistage Vacuum Generator

- ◇ Max.vacuum level: -95kPa
- ◇ Max.vacuum flow: 372NL/min



ELECTRONICS PACKAGING METAL SHEET



RoHS

#### 70 ABM/ABX Series

##### Mini Combined Type Vacuum Generator

- ◇ Max.vacuum level: -92kPa
- ◇ Max.vacuum flow: 32NL/min



METAL SHEET PACKAGING PLASTIC



RoHS

# Vacuum Generators Series

## Products overview



### Vacuum Generators

#### 75 AMC Series

##### Multistage Vacuum Generator

- ◇ Max.vacuum level: -95kPa
- ◇ Max.vacuum flow: 1,650NL/min



RoHS

#### 102 AZR Series

##### Mini Vacuum Generator With Fast Blow-off

- ◇ Max.vacuum level: -88kPa
- ◇ Max.vacuum flow: 12.5NL/min

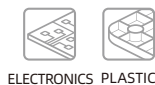

RoHS

#### 81 AM/AL/AH Series

##### Multistage Vacuum Generator

- ◇ Max.vacuum level: -100.8kPa
- ◇ Max.vacuum flow: 1,230NL/min



RoHS

#### 107 ABT Series

##### Mini Vacuum Generator

- ◇ Max.vacuum level: -92kPa
- ◇ Max.vacuum flow: 46NL/min



RoHS

#### 90 AM/AL Series

##### Combined Type Multistage Vacuum Generator

- ◇ Max.vacuum level: -92kPa
- ◇ Max.vacuum flow: 3,970NL/min



RoHS

#### 110 ABP Series

##### Vacuum Generator with Fast Blow-off

- ◇ Max.vacuum level: -81kPa
- ◇ Max.vacuum flow: 38NL/min



RoHS

#### 95 AMD Series

##### Large Flow Vacuum Generator

- ◇ Max.vacuum level: -95kPa
- ◇ Max.vacuum flow: 1,410NL/min



RoHS

#### 112 ABQ Series

##### Vacuum Generator with Fast Blow-off

- ◇ Max.vacuum level: -81kPa
- ◇ Max.vacuum flow: 38NL/min



RoHS

#### 99 AZW Series

##### Large Flow Integrated Vacuum Generator

- ◇ Max.vacuum level: -95kPa
- ◇ Max.vacuum flow: 140NL/min



RoHS

#### 114 AEVC Series

##### Vacuum Generator with Fast Blow-off

- ◇ Max.vacuum level: -85kPa
- ◇ Max.vacuum flow: 35NL/min



RoHS

# Vacuum Generators Series

## Products overview



### Vacuum Generators

#### 117 AZL Series

##### Multistage Vacuum Generator

- ◇ Max.vacuum level: -84kPa
- ◇ Max.vacuum flow: 200NL/min



#### 133 ACV Series

##### Basic Vacuum Generator

- ◇ Max.vacuum level: -90kPa
- ◇ Max.vacuum flow: 350NL/min



#### 121 ALH Series

##### Basic Vacuum Generator

- ◇ Max.vacuum level: -90kPa
- ◇ Max.vacuum flow: 9.5NL/min



#### 138 ASBP Series

##### Basic Vacuum Generator

- ◇ Max.vacuum level: -85kPa
- ◇ Max.vacuum flow: 72NL/min



#### 124 AZH Series

##### Basic Vacuum Generator

- ◇ Max.vacuum level: -88kPa
- ◇ Max.vacuum flow: 85NL/min



#### 141 ALS Series

##### Linear Single Stage Vacuum Generator

- ◇ Max.vacuum level: -85kPa
- ◇ Max.vacuum flow: 14.4NL/min



#### 130 AZU Series

##### Basic Vacuum Generator

- ◇ Max.vacuum level: -85kPa
- ◇ Max.vacuum flow: 21NL/min



#### 144 ACP Series

##### Conveying Vacuum Generator

- ◇ Max.vacuum level: -84kPa
- ◇ Max.vacuum flow: 3,390NL/min



# Vacuum Generators Series

## Products overview

### Vacuum Generators

#### 147 ACPF Series

##### Conveying Vacuum Generator

- ◇ Max.vacuum level: -35kPa
- ◇ Max.vacuum flow: 5,610NL/min



#### 152 APB Series

##### High Pressure Vacuum Blower

- ◇ Max.vacuum level: -48kPa
- ◇ Max.vacuum flow: 1,110m<sup>3</sup>/h



#### 150 ACP5 Series

##### Conveying Vacuum Generator

- ◇ Max.vacuum level: -12kPa
- ◇ Max.vacuum flow: 8,640NL/min



# AZK Series

## Integrated Vacuum Generator

**AIRBEST**



ELECTRONICS    PACKAGING    PLASTIC



### Features

- ◇ Energy-efficient nozzle design
- ◇ With energy-saving control device
- ◇ With normally open vacuum supply valve
- ◇ Small size and light weight. The volume is 85cm<sup>3</sup>
- ◇ Transparent filter housing
- ◇ Single body with L bracket, DIN guide rail installation for integrated body, centralized air supply

### Advantages

- ◇ Vacuum flow increased by 50% and air consumption decreased by 30%
- ◇ Air consumption reduced by 90%(compared with non-energy saving type)
- ◇ Power outage or power off does not affect vacuum producing and prevent the workpiece from falling
- ◇ The device is compact and can be installed directly in the handling system
- ◇ The cleanliness is visible and easy to replace
- ◇ Simple installation, can be installed directly on the distribution box
- ◇ It has the function of automatic blow-off

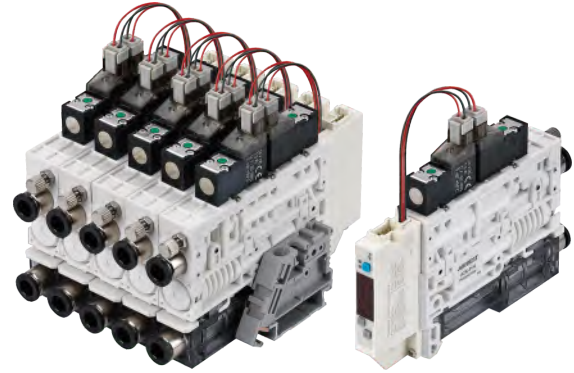

### Applications

- ◇ Integrated vacuum generator for handling airtight and slightly porous workpieces
- ◇ Vacuum producing and monitoring in automation systems
- ◇ For robot handling applications and linear axes
- ◇ Pick and place applications with very short time
- ◇ Used for systems that require high dynamic handling of workpieces and with limited space
- ◇ Usually used for handling small parts in fully automated systems

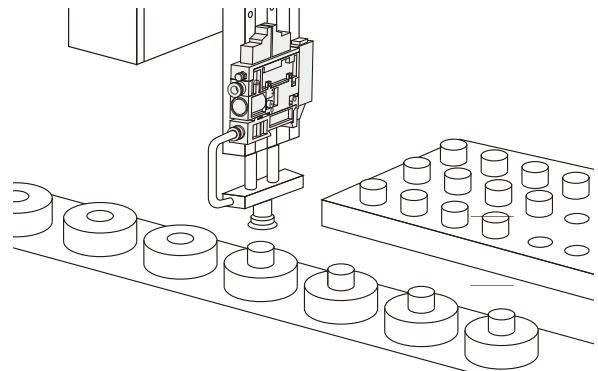

### Structure - With vacuum source type (Vacuum generator type)

- ◇ (1) Vacuum supply valve
- ◇ (2) Vacuum release valve
- ◇ (3) Vacuum pressure switch
- ◇ (4) Vacuum release adjusting valve
- ◇ (5) Air supply port
- ◇ (6) Silencer
- ◇ (7) Vacuum port
- ◇ (8) Vacuum filter
- ◇ (9) DIN guide rail installation

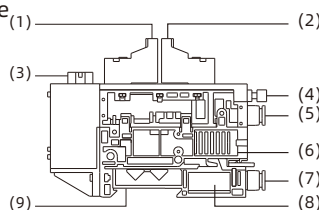

### Structure - Without vacuum source type (Vacuum pump type)

- ◇ (1) Vacuum supply valve
- ◇ (2) Vacuum release valve
- ◇ (3) Vacuum pressure switch
- ◇ (4) Vacuum release adjusting valve
- ◇ (5) Air supply port
- ◇ (6) Vacuum pump connector
- ◇ (7) Vacuum port
- ◇ (8) Vacuum filter
- ◇ (9) DIN guide rail installation

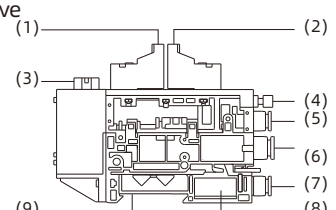

Vacuum Generator

AZK

AZQ

AZX

AZD

AGS

AGP

AGX

AGE

ABM/ABX

ABM/ABX  
Combined Type

AMC

AM/AL/AH

AM/AL  
Combined Type

AMD

AZW

AZR

ABT

ABP

ABQ

AEVC

AZL

ALH

AZH

AZU

ACV

ASBP

ALS

ACP

ACPF

ACPS

APB

# AZK Series

## Integrated Vacuum Generator

### Structure-Vacuum generator type - Pipe connection at the exhaust port

- ◇ (1) Vacuum supply valve
- ◇ (2) Vacuum release valve
- ◇ (3) Vacuum pressure switch
- ◇ (4) Vacuum release adjusting valve
- ◇ (5) Air supply port
- ◇ (6) Pipe connection at the exhaust port
- ◇ (7) Vacuum port
- ◇ (8) Vacuum filter
- ◇ (9) DIN guide rail installation

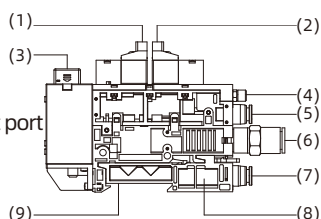

### Structure-Vacuum generator type - External silencer

- ◇ (1) Vacuum supply valve
- ◇ (2) Vacuum release valve
- ◇ (3) Vacuum pressure switch
- ◇ (4) Vacuum release adjusting valve
- ◇ (5) Air supply port
- ◇ (6) Silencer
- ◇ (7) Vacuum port
- ◇ (8) Vacuum filter
- ◇ (9) DIN guide rail installation

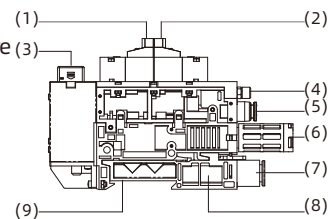

### How to order

**AZK - S × 8 - NO - N - D - 08**  

①
②
③
④
⑤
⑥
⑦

① Series	② Specification	③ Stack	④ Control valve specification
AZK	S - Low vacuum level type X - High vacuum level type P - Low air supply pressure and high vacuum level type L - Large flow type B - Vacuum pump type	Nil - Single body 2 3 ... 8	Nil - Supply valve NC + release valve NC NO - Supply valve NO + release valve NC STD - Supply valve (Self - holding type) + release valve NC
⑤ Vacuum switch			
Nil	Without vacuum switch	NR	NPN, With RS485 communication
N	NPN, without energy saving function	PR	PNP, With RS485 communication
P	PNP, without energy saving function	NER	NPN, With RS485 communication
NE	NPN, with energy saving function	PER	PNP, With RS485 communication
PE	PNP, with energy saving function	NEO	NPN, NO type new energy-saving function
NK	NPN, with centralized wiring function	PEO	PNP, NO type new energy-saving function
PK	PNP, with centralized wiring function		
⑥ Bracket		⑦ Exhaust port connection pipe diameter	
Nil	Single air supply, without bracket	Nil	Built-in/external silencer
F	Single air supply, with bracket(single body)	8	φ8 Quick plug connector
D	Single air supply, guide rail installation(integrated)	10	φ10 Quick plug connector
DP	Centralized air supply, guide rail installation(integrated)		

- ◇ Note: 1. In the vacuum switch options, NE/PE/NER/PER/NEO/PEO are equipped with check valves (disc valves) and have energy-saving functions. The other options have no energy-saving functions.
- 2. Energy saving function is not optional for L-large flow type and B-Vacuum pump type.
- 3. Centralized air supply is not optional for B-Vacuum pump type.
- 4. Vacuum switches NE/PE/NK/PK/NER/PER/NEO/PEO are not available in STD - supply valve (self - holding type)
- 5. In the vacuum switch options, the N/P/NR/PR types have no energy-saving functions and include solenoid valve wires (30mm in length, DC24V power supply). The others are connected to the control valve by the vacuum switch.
- 6. Except for the N/P/NR/PR types, all other pressure switches have the function of automatic blow-off back after the vacuum signal is disconnected. The function can be set to be on or off in the F8 option of the pressure switch. STD - supply valve (self - holding type) + release valve NC does not have this function.
- 7. The new energy-saving function NEO/PEO can only select NO - supply valve NO + release valve NC. After connecting the air source, the maximum vacuum level can be achieved and the energy-saving function is activated.

# AZK Series

## Integrated Vacuum Generator



### Technical parameters

Model	Air supply pressure range bar	Rated air supply pressure bar	Max. vacuum level -kPa	Max. vacuum flow NL/min	Max. break flow rate NL/min	Air consumption NL/min	Noise level dB(A)	Without pressure switch	Weight g With pressure switch
AZK-S	3.0~6.0	6.0	74	44	60	26	64~68	88.5	102.5
AZK-X	3.0~6.0	5.0	91	41	54	29	64~68	88.5	102.5
AZK-P	3.0~6.0	3.7	88	40	46	32	64~68	88.5	102.5
AZK-L	3.0~6.0	5.0	90	68	48	85	74~80	102	114
AZK-B	3.0~6.0	-	-	40(Note)	100	-	-	101.5	113.5

Model	Recommended hose dia.(mm) Air supply port P	Recommended hose dia.(mm) Vacuum pump connector	Recommended hose dia.(mm) Vacuum port V	Recommended hose dia.(mm) Exhaust port V
AZK-S	φ6	-	-	Built-in silencer/φ8/φ10
AZK-X	φ6	-	-	Built-in silencer/φ8/φ10
AZK-P	φ6	-	-	Built-in silencer/φ8/φ10
AZK-L	φ6	-	-	External silencer/φ8/φ10
AZK-B	φ4	φ6	φ6	-

◇ Note: For model AZK-B, the max. vacuum flow per piece is 40NL/min

### Vacuum flow(NL/min) at different vacuum levels(-kPa)

Model	Air supply pressure bar	Air consumption NL/min	0	10	20	30	40	50	60	70	80	90	Max. vacuum level -kPa
AZK-S	6.0	26	44.0	38.0	32.0	22.0	12.0	10.0	8.5	4.0	-	-	74
AZK-X	5.0	29	41.0	36.0	26.0	13.7	11.0	9.3	6.6	4.6	2.7	2.0	91
AZK-P	3.7	32	40.0	35.0	25.2	17.7	10.9	8.0	5.6	4.2	1.5	1.0	88
AZK-L	5.0	85	68.0	62.0	42.0	26.0	20.6	16.2	9.0	7.2	7.2	5.0	90

### Evacuation time(s/L) to reach different vacuum levels(-kPa)

Model	Air supply pressure bar	Air consumption NL/min	10	20	30	40	50	60	70	80	90	Max. vacuum level -kPa
AZK-S	6.0	26	0.01	0.19	0.50	1.02	1.72	2.60	3.88	-	-	74
AZK-X	5.0	29	0.02	0.14	0.47	0.96	1.56	2.50	3.87	6.00	-	91
AZK-P	3.7	32	0.05	0.30	0.71	1.26	1.95	2.97	4.49	6.95	-	88
AZK-L	5.0	85	0.06	0.16	0.33	0.60	0.95	1.43	2.14	3.03	6.16	90

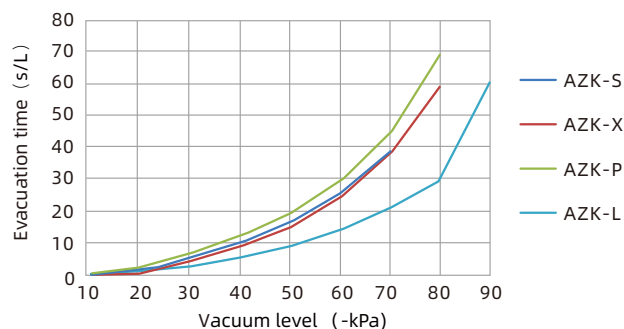
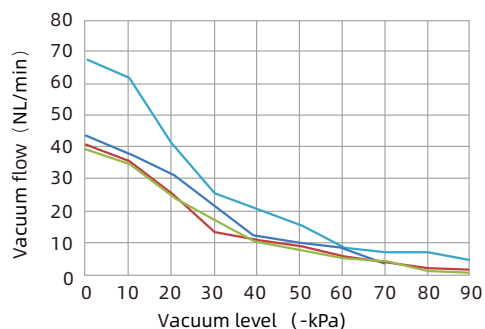

# AZK Series

## Integrated Vacuum Generator

### Technical parameters - Pressure switch

Model	ZPDC-N/P/NR/PR	ZPDC-NE/PE/NK/PK/NER/PER/NEO/PEO
Pressure range	-100~100kPa	-100~100kPa
Setting pressure range	-105~105kPa	-105~105kPa
Proof pressure	500kPa	500kPa
General gas	Air, Non-corrosive, non flammable gas	Air, Non-corrosive, non flammable gas
Power supply voltage	24V DC±10%, RIPPLE (P-P) 10% or less	24V DC±10%, RIPPLE(P-P)10% or less
Current consumption	≤40mA(Without load)	≤40mA (Without load)
Switch output Output mode	2NPN / 2PNP open collector output or 485-A、485-B output+1~5V linear analog output	1NPN / 1PNP open collector output or 485-A、485-B output
Max. load current	125mA	125mA
Max. supply voltage	30V DC (NPN ) 24V DC (PNP)	24V DC
Residual voltage	≤1.5V	≤1.5V
Response time	≤2.5ms (chattering-proof function: 25ms, 100ms, 250ms, 500ms, 1000ms, 1500ms selectable)	≤2.5ms (chattering-proof function: 2.5ms, 20ms, 100ms, 500ms, 1000ms, 1999ms selectable)
Output short circuit protection	Yes	OUT switch: Yes; V-Sol/D-Sol: No
Repeatability	±0.2%F.S.±1 digit	
Display	3½LED 7 segment display (Red) display (Sampling rate: 5 times/sec)	
Indicator accuracy	±2% F.S. ±1 digit	
Switch ON indicator	OUT1:Green/OUT2:Red	
Environmental resistance IP Grade	IP40	
Ambient temp.range	Operation: 0~50°C	
Withstand voltage	1000VAC in 1minute (between case and lead wire)	
Insulation resistance	50MΩ min. (at 500V DC, between case and lead wire)	
Temperature characteristic	±2%F.S. ( at temperature range of 0~50°C)	
Lead wire	Oil proof PVC cable (0.15mm <sup>2</sup> )	

### Air circuit schematic diagram

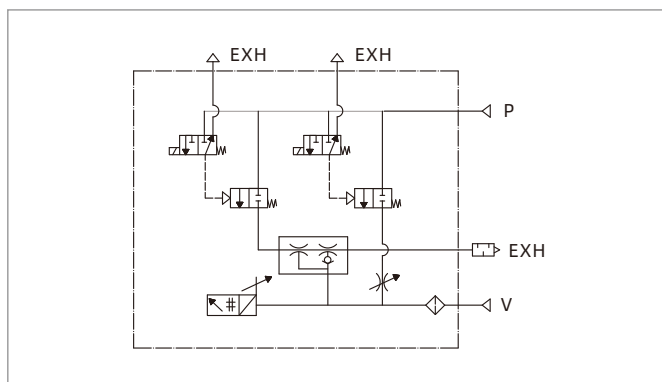

AZK-S(X/P/L)-N(P/NK/PK/NR/PR)

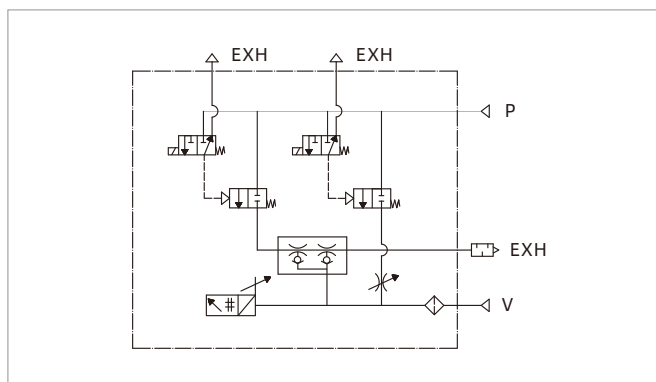

AZK-S(X/P)- NE(PE/NER/PER/NEO/PEO)

# AZK Series

## Integrated Vacuum Generator

### Air circuit schematic diagram

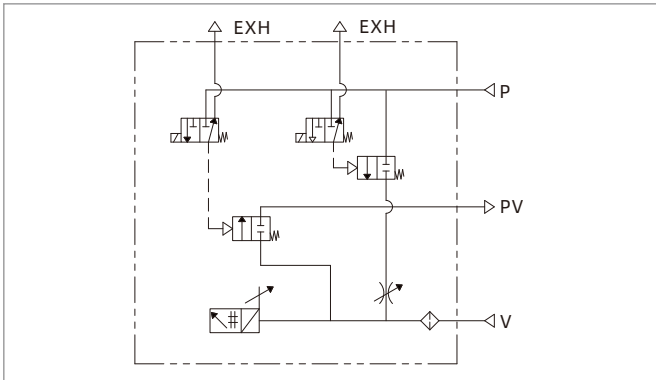

AZK-B-N(P)

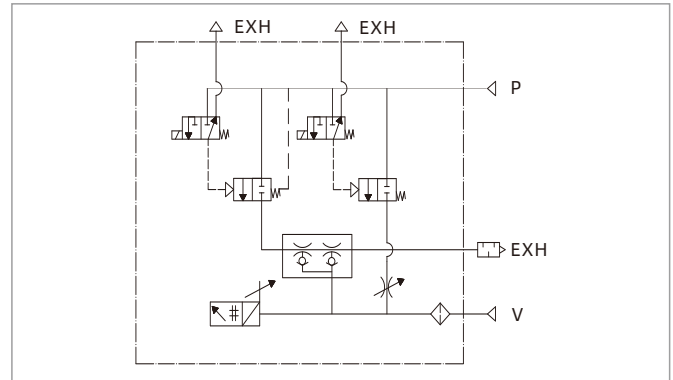

AZK-S(X/P/L)-STD

### Output circuit wiring diagrams

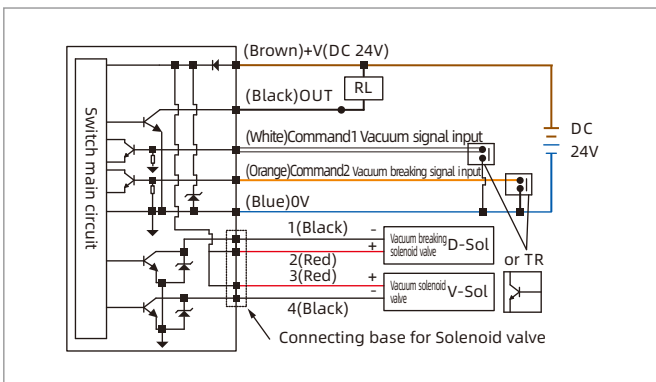

ZPDC-NE(NK/NEO)NPN output

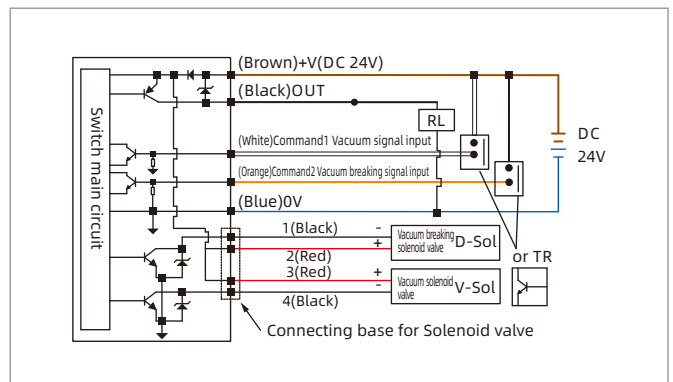

ZPDC-PE(PK/PEO)PNP output

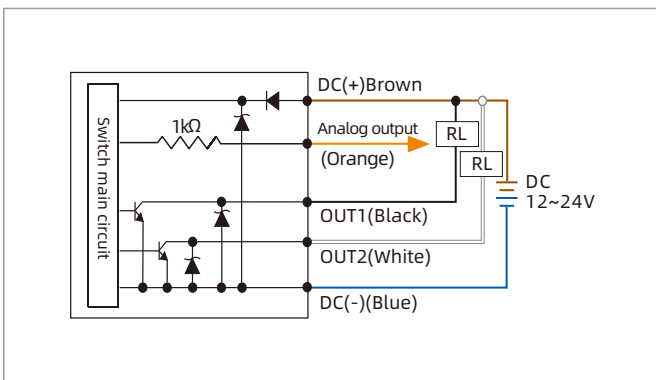

ZPDC-N 2NPN+1Analog voltage output(1~5V)

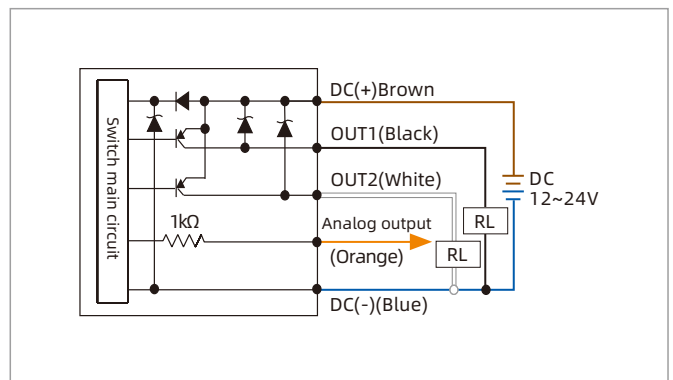

ZPDC-P 2PNP+1Analog voltage output(1~5V)

# AZK Series

## Integrated Vacuum Generator



### Output circuit wiring diagrams

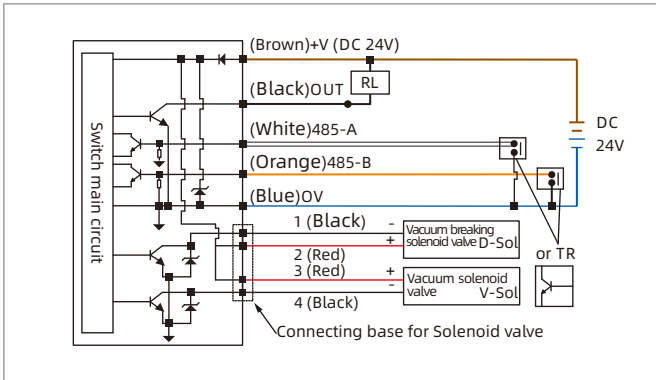

ZPDC-NR-E NPN output

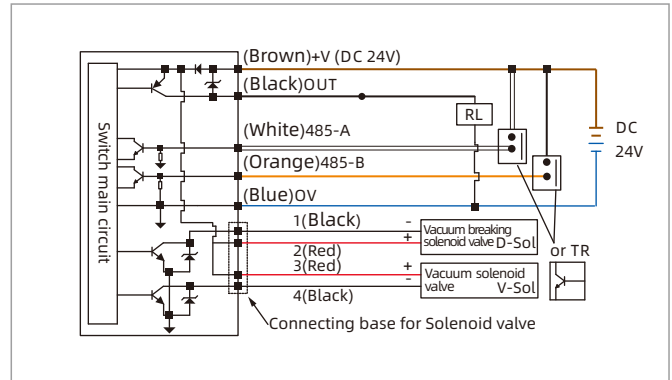

ZPDC-PR-E PNP output

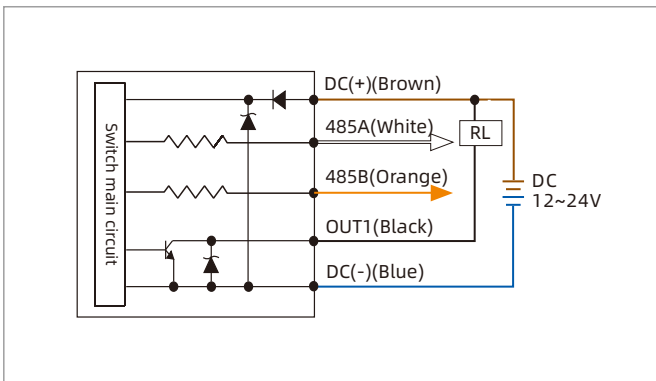

ZPDC-NR 1NPN+1 set Rs485

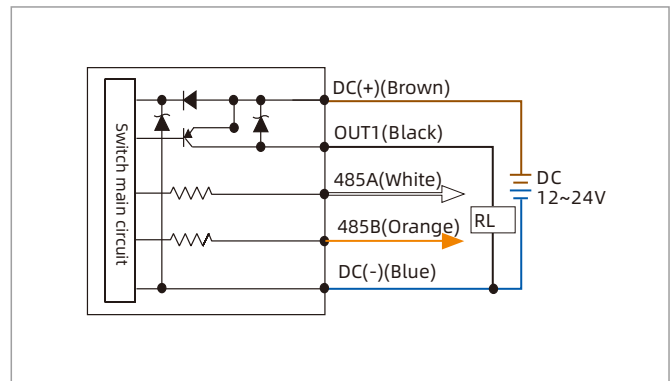

ZPDC-PR 1PNP+1 set Rs485

### Centralized air supply dimensions(mm)

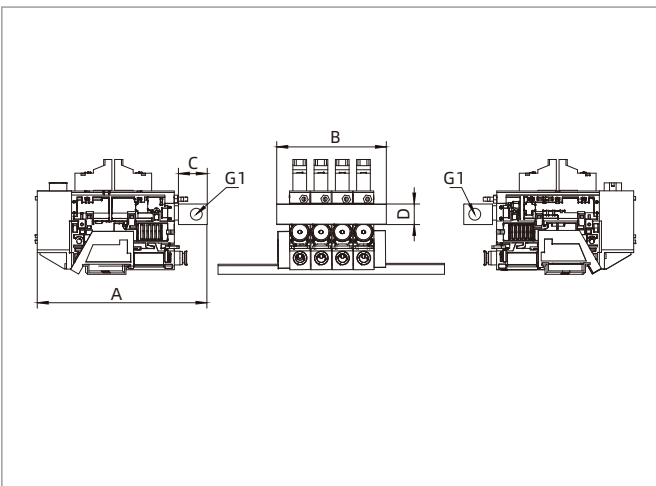

Stack	A	B	C	D	G1
2	124	49	21	15	G1/8
3	124	64.5	21	15	G1/8
4	124	80	21	15	G1/8
5	124	95.5	21	15	G1/8
6	124	111	21	15	G1/8
7	124	126.5	21	15	G1/8
8	124	142	21	15	G1/8

Max.number of manifold stations that can operate simultaneously	AZK-X	AZK-P	AZK-S	AZK-L
Air supply from one side	6	6	6	4
Air supply from both sides	8	8	8	8

# AZK Series

## Integrated Vacuum Generator

### Dimensions(mm)

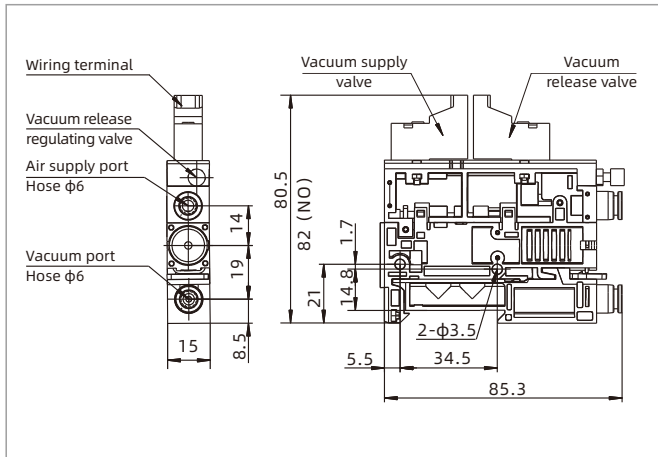

AZK-□ Single body

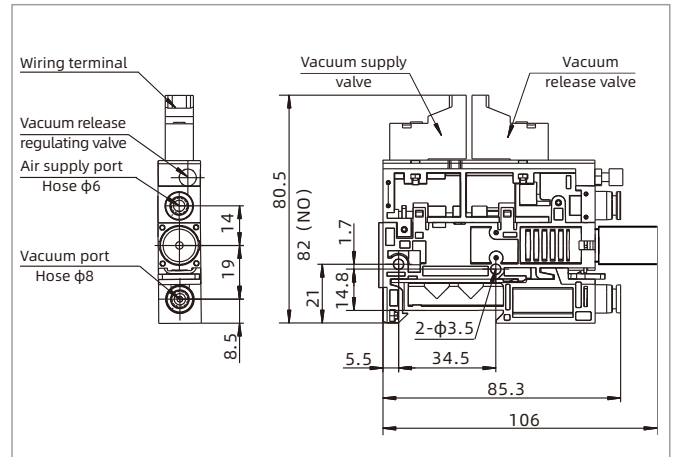

AZK-L Single body

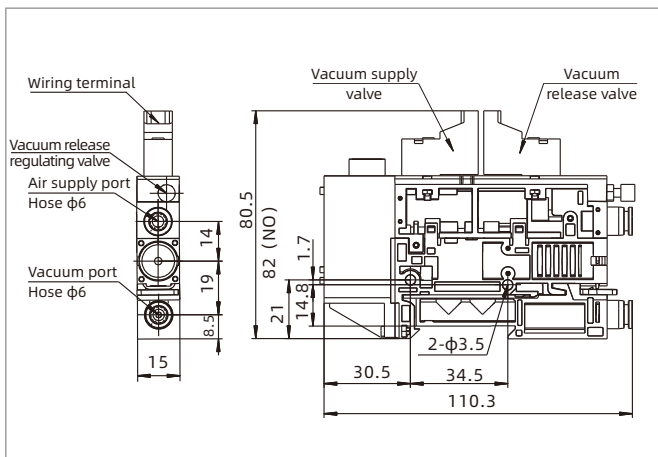

AZK-□-□ Single body with pressure switch

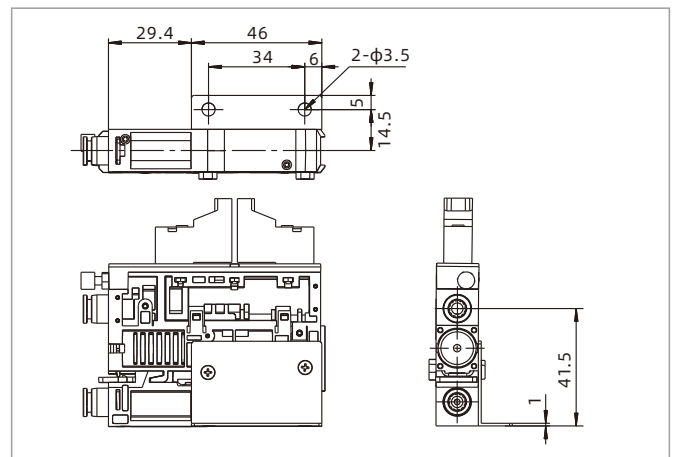

AZK-□-F Single body with mounting bracket

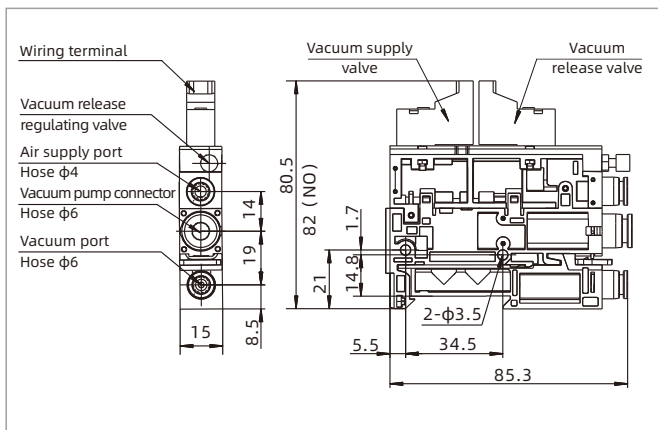

AZK-B Single body

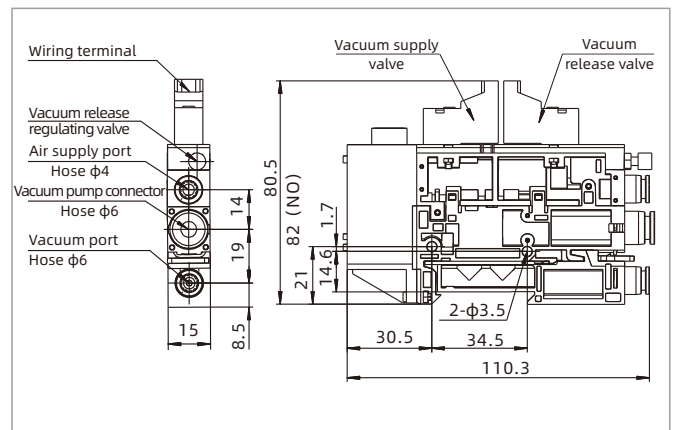

AZK-B-□ Single body with pressure switch

Vacuum Generator

AZK

AZQ

AZX

AZD

AGS

AGP

AGX

AGE

ABM/ABX

ABM/ABX  
Combined Type

AMC

AM/AL/AH

AM/AL  
Combined Type

AMD

AZW

AZR

ABT

ABP

ABQ

AEVC

AZL

ALH

AZH

AZU

ACV

ASBP

ALS

ACP

ACPF

ACPS

APB

# AZK Series

## Integrated Vacuum Generator

### Dimensions(mm)

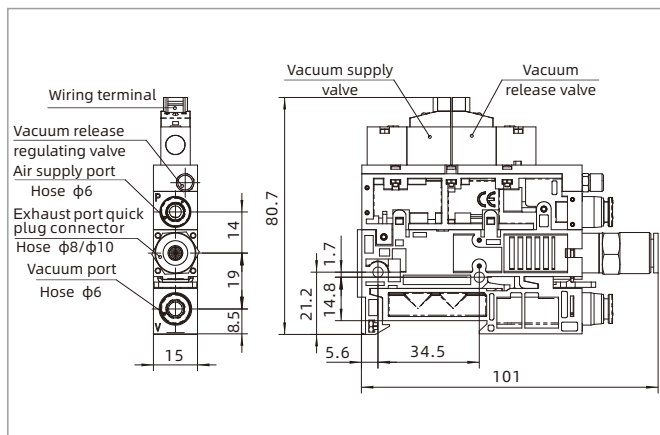

AZK-□-08(10) Single body exhaust port quick plug connector

### Installation Diagram

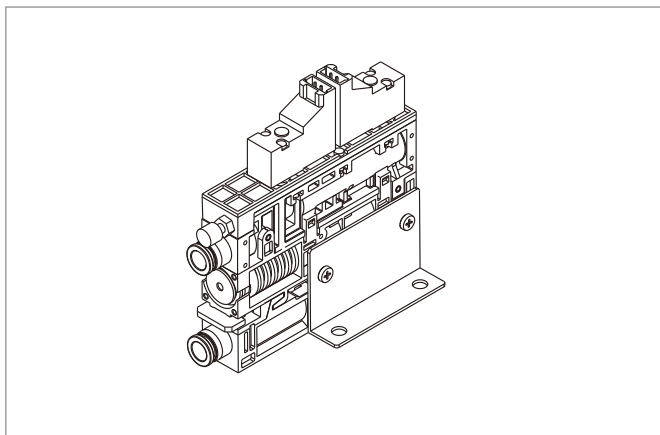

Single body with bracket

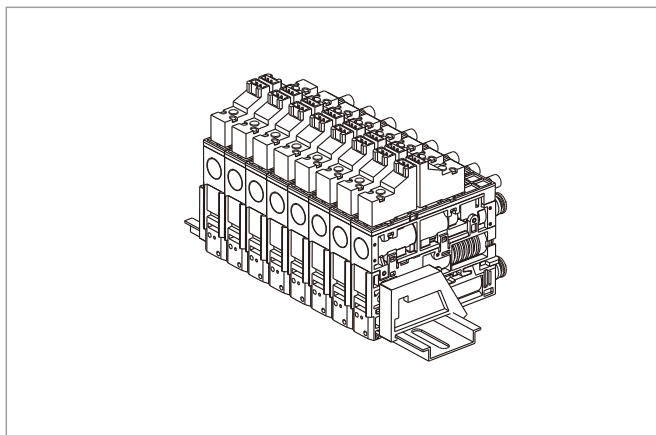

Combined type with guide rail

# AZK Series

## Integrated Vacuum Generator

### Repair kits

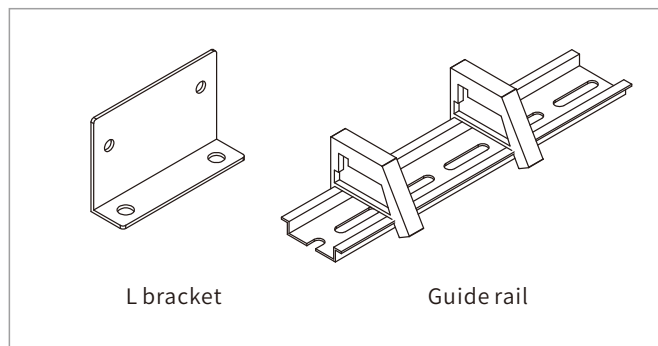
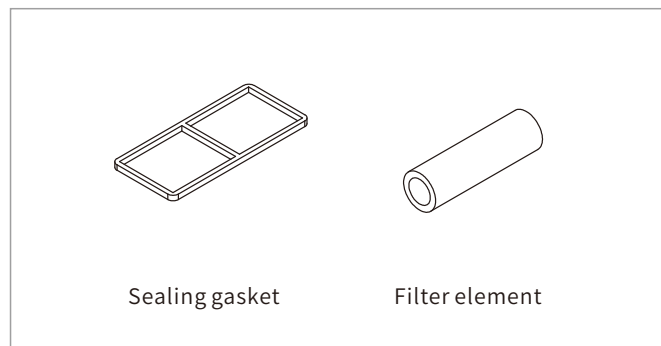

Item	Model	Remark
Filter parts	AZK-FE	Filter element + sealing gasket
Filter parts	AZK-L-FE	Filter element + sealing gasket (Large flow)
Solenoid valve leadwire	AZK-N	Plug lead wire length 300mm
Solenoid valve leadwire	AZK-3M	Plug lead wire length 3000mm
Energy-saving leadwire	AZK-NE	Ends lead wire
Solenoid valve	AZK-NC-R	Normally closed solenoid valve (NC)
Solenoid valve	AZK-NO-R	Normally open solenoid valve(NO)
Solenoid valve	AZK-STD-R	Bistable solenoid valve
Bracket mounting parts	AZK-F	L bracket+M3.5x20screw/nut(2 pcs each)
Pressure switch	ZPDC-N	NPN output pressure gauge
Pressure switch	ZPDC-NE	NE(NPN output) pressure gauge
Pressure switch	ZPDC-P	PNP output pressure gauge
Pressure switch	ZPDC-PE	PE(PNP output) pressure gauge
Pressure switch	ZPDC-NR	NPN output with RS485 communication pressure gauge
Pressure switch	ZPDC-PR	PNP output with RS485 communication pressure gauge
Pressure switch	ZPDC-NER	NE (NPN output) with RS485 communication pressure gauge
Pressure switch	ZPDC-PER	PE (PNP output) with RS485 communication pressure gauge
Pressure switch	ZPDC-NEO	NE (NPN output) new NO type vacuum gauge
Pressure switch	ZPDC-PEO	PE (PNP output) new NO type vacuum gauge
Pressure switch power cord	ZPDC-CB	Pressure switch 5 core wires
Guide rail mounting parts(2-3 layers)	AZK-2-D	Length 130mm
Guide rail mounting parts(4-5 layers)	AZK-4-D	Length 165mm
Guide rail mounting parts(6-7 layers)	AZK-6-D	Length 200mm
Guide rail mounting parts(8 layers)	AZK-8-D	Length 235mm

# AZQ Series

## Mini Integrated Vacuum Generator

**AIRBEST**



### Features

- ◇ Multi-nozzle design
- ◇ Small size and light weight. The volume is 43.5cm<sup>3</sup>
- ◇ Centralized air supply
- ◇ No noise (vacuum pump type)
- ◇ With digital vacuum pressure switch

### Advantages

- ◇ The device is compact and can be installed directly in the handling system
- ◇ Simple installation, can be installed directly on the distribution box
- ◇ Vacuum pump type is suitable for centralized vacuum station system



### Applications

- ◇ Vacuum producing and monitoring in automation systems
- ◇ For robot handling applications and linear axes
- ◇ Pick and place applications with very short time
- ◇ Used for systems that require high dynamic handling of workpieces and with limited space
- ◇ Usually used for handling small parts in fully automated systems

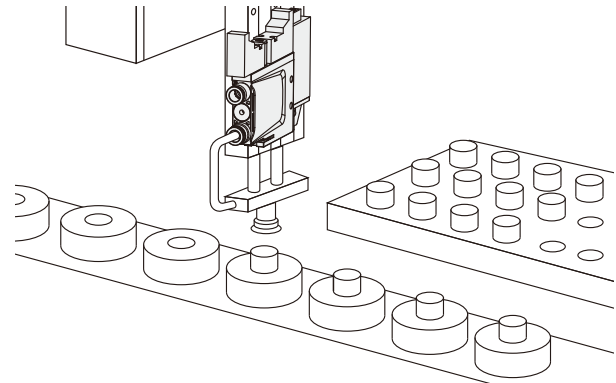

### Structure - Without vacuum source type (Vacuum pump type)

- ◇ (1) Vacuum release valve
- ◇ (2) Vacuum release adjusting valve
- ◇ (3) Vacuum supply valve
- ◇ (4) Vacuum pressure switch
- ◇ (5) Air supply port
- ◇ (6) Vacuum pump connector
- ◇ (7) Vacuum port

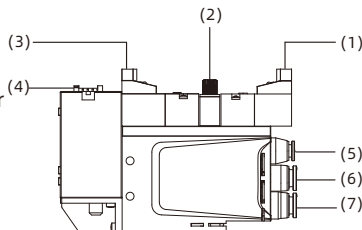

### With vacuum source type (Vacuum generator type)

- ◇ (1) Vacuum release valve
- ◇ (2) Vacuum release adjusting valve
- ◇ (3) Vacuum supply valve
- ◇ (4) Vacuum pressure switch
- ◇ (5) Air supply port
- ◇ (6) Exhaust port
- ◇ (7) Vacuum port

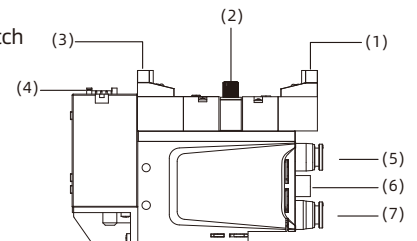

# AZQ Series

## Mini Integrated Vacuum Generator

### How to order

**AZQ - T × 8 - 04 - N - DP**  
 ①            ②            ③            ④            ⑤            ⑥

① Series	② Specifications	③ Stack	④ Vacuum port specification	⑤ Vacuum switch	⑥ Air supply
AZQ	X - High vacuum level type T - Large flow type B - Vacuum pump type	Nil - Single body 2 3 .... 10	Nil - φ6One-touch fitting 04 - φ4One-touch fitting	N - 2NPN output + 1 analog output (1~5V) P - 2PNP output + 1 analog output (1~5V) NK - NPN, with centralized wiring function PK - PNP, with centralized wiring function	Nil - Individual air supply DP - Centralized air supply

◇ Note: 1. It is recommended to install an air filter with a filtration accuracy of 5um or less for positive pressure air supply of the vacuum generator (without the need for an oil mist filter)  
2. Only concentrated air supply for non-single type

### Technical parameters

Model	Air supply pressure range bar	Rated air supply pressure bar	Max. vacuum level -kPa	Max. vacuum flow NL/min	Air consumption NL/min	Noise dB(A)	Weight g	Recommended hose dia.(mm)	Air supply port P	Vacuum port V	Vacuum pump connector
AZQ-X	3.0~6.0	5.0	91	12	8.2	64~70	75.4	φ6	φ4/φ6	-	-
AZQ-T	3.0~6.0	4.5	84	16	15.5	64~70	75.4	φ6	φ4/φ6	-	-
AZQ-B	3.0~6.0	-	-	40(Note)	-	-	78.2	φ4	φ4/φ6	φ6	φ6

◇ Note: For model AZQ-B-□-□-□-DP, the max. vacuum flow per piece is 15NL/min

### Vacuum flow(NL/min) at different vacuum levels(-kPa)

Model	Air supply pressure bar	Air consumption NL/min	0	10	20	30	40	50	60	70	80	90	Max. vacuum level -kPa
AZQ-X	5.0	8.2	12	9.5	6.4	5.6	5.1	4.4	3.2	2.1	0.9	-	90
AZQ-T	4.5	15.5	16	14.5	10.7	9.1	8.0	6.7	4.8	2.8	-	-	84

### Evacuation time(s/L) to reach different vacuum levels(-kPa)

Model	Air supply pressure bar	Air consumption NL/min	10	20	30	40	50	60	70	80	90	Max. vacuum level -kPa
AZQ-X	5.0	8.2	0.49	1.37	2.90	4.70	6.98	10.03	14.90	23.20	59.52	90
AZQ-T	4.5	15.5	0.34	0.76	1.51	2.40	3.76	5.61	8.94	16.86	-	84

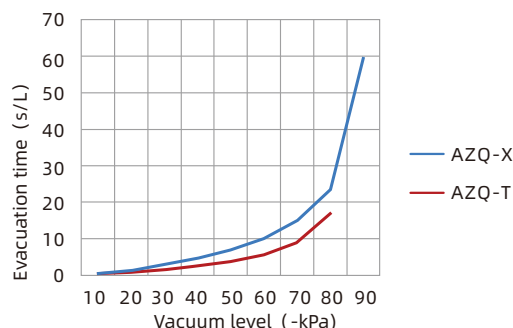
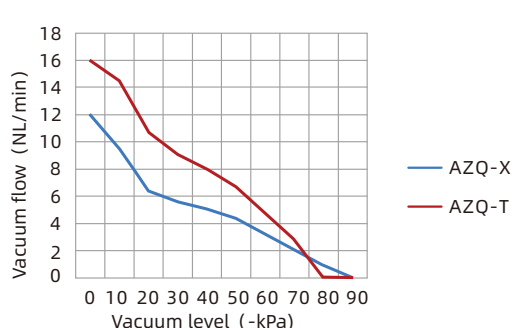

# AZQ Series

## Mini Integrated Vacuum Generator

### Technical parameters - Pressure switch

Model	ZPDC-□
Pressure range	-100~100kPa
Setting pressure range	-105~105kPa
Proof pressure	500kPa
General gas	Air, Non-corrosive, non flammable gas
Power supply voltage	12-24V DC±10%, RIPPLE (P-P) 10% or less
Current consumption	≤40mA(Without load)
Switch output Output mode	2NPN or 2PNP open collector output+1~5V linear analog output
Max. load current	125mA
Max. supply voltage	30V DC (NPN) 24V DC (PNP)
Residual voltage	≤1.5V
Response time	≤2.5ms (chattering-proof function: 25ms, 100ms, 250ms, 500ms, 1000ms, 1500ms selectable)
Output short circuit protection	Yes
Repeatability	±0.2%F.S.±1 digit
Display	3½LED 7 segment display (Red) display (Sampling rate: 5 times/sec)
Indicator accuracy	±2% F.S. ±1 digit At ambient temperature: 25±3°C
Switch ON indicator	OUT1:Green/OUT2:Red
Environmental resistance IP Grade	IP40
Ambient temp.range	Operation: 0~50°C
Withstand voltage	1000VAC in 1minute (between case and lead wire)
Insulation resistance	50MΩ min. (at 500V DC, between case and lead wire)
Temperature characteristic	±2%F.S. (at temperature range of 0~50°C)
Lead wire	Oil proof PVC cable (0.15mm <sup>2</sup> )

### Output circuit wiring diagrams

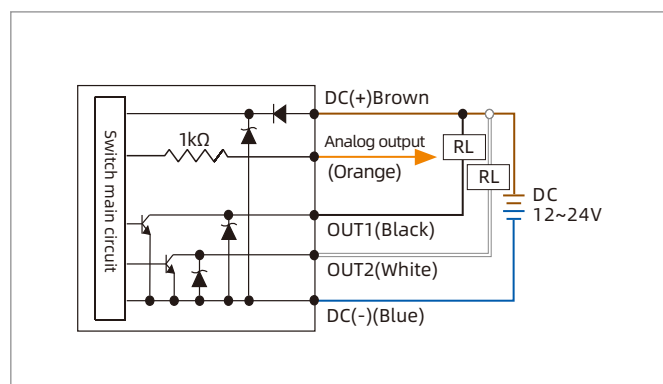

ZPDC-N 2NPN+1 Analog voltage output (1-5V)

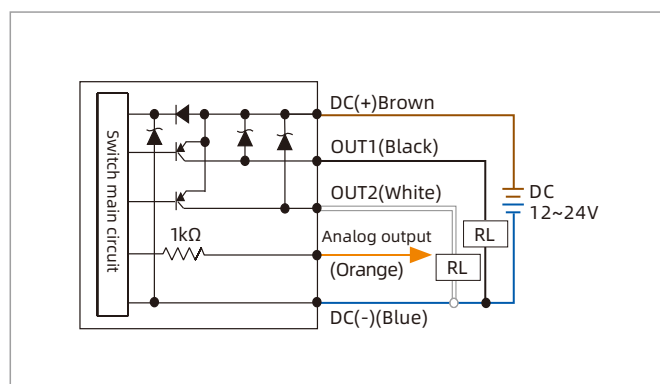

ZPDC-P 2PNP+1 Analog voltage output (1-5V)

# AZQ Series

## Mini Integrated Vacuum Generator

### Centralized air supply dimensions(mm)

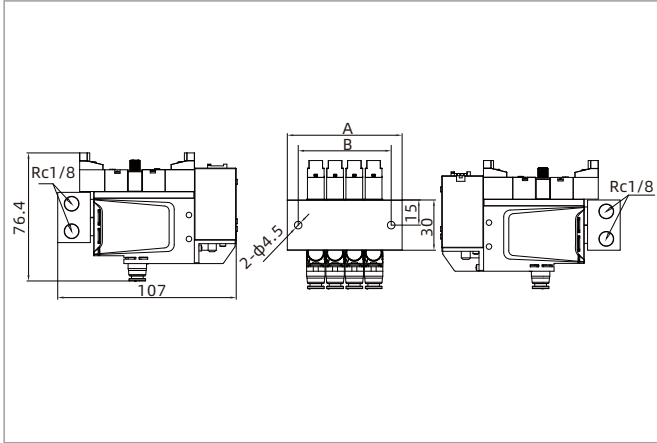

Vacuum pump type

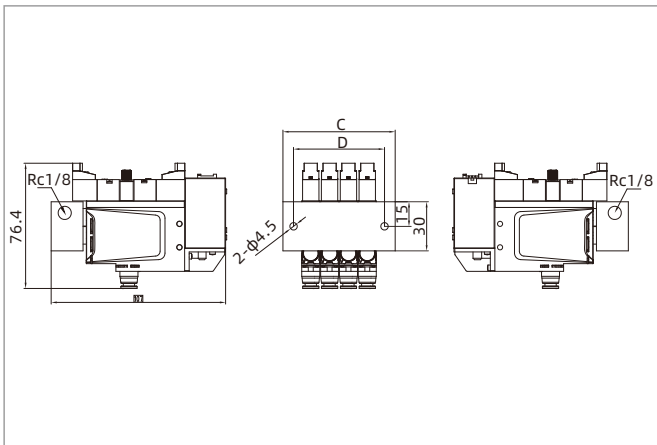

Vacuum generator type

Stack	A	B	C	D
2	45.5	32.5	45.5	32.5
4	68.5	55.5	68.5	55.5
6	91.5	78.5	91.5	78.5
8	114.5	101.5	114.5	101.5
10	-	-	137.5	124.5

- ◇ Note: 1. AZQ-X/T/B dual integrated vacuum generator is a standard product, while using single piece with dual centralized gas supply, vacant port should be blocked  
 2. While using 5 pieces or more AZQ-B for integrating, recommend air supply on both sides

### Dimensions(mm)

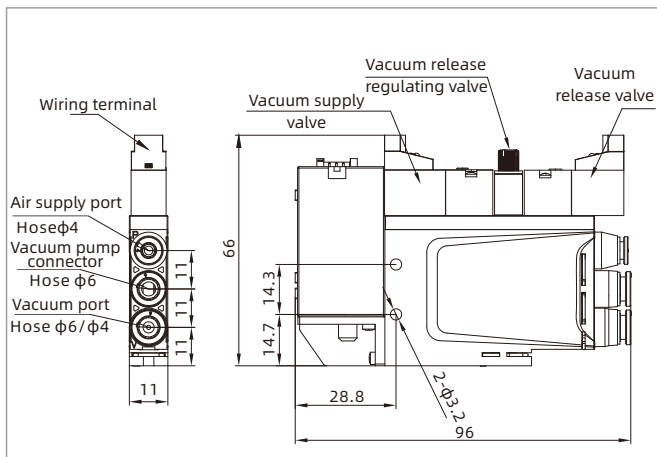

AZQ-B-□ Single body of vacuum pump type

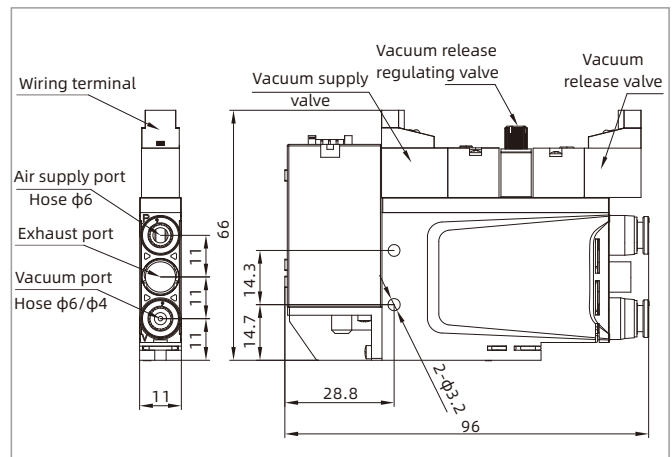

AZQ-□-□ Single body of vacuum generator type

Vacuum Generator

AZK

AZQ

AZX

AZD

AGS

AGP

AGX

AGE

ABM/ABX

ABM/ABX Combined Type

AMC

AM/AL/AH

AM/AL Combined Type

AMD

AZW

AZR

ABT

ABP

ABQ

AEVC

AZL

ALH

AZH

AZU

ACV

ASBP

ALS

ACP

ACPF

ACPS

APB

# AZQ Series

## Mini Integrated Vacuum Generator

### Air circuit schematic diagram

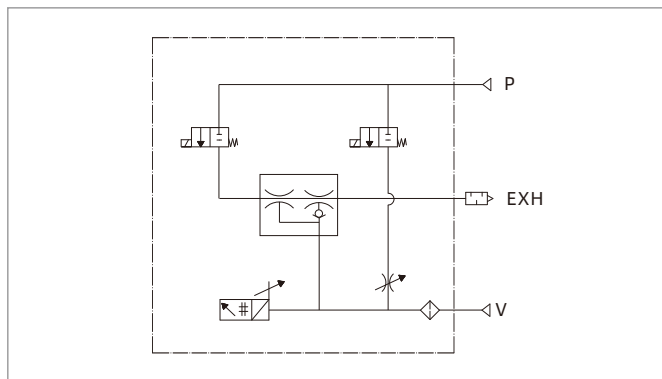

AZQ

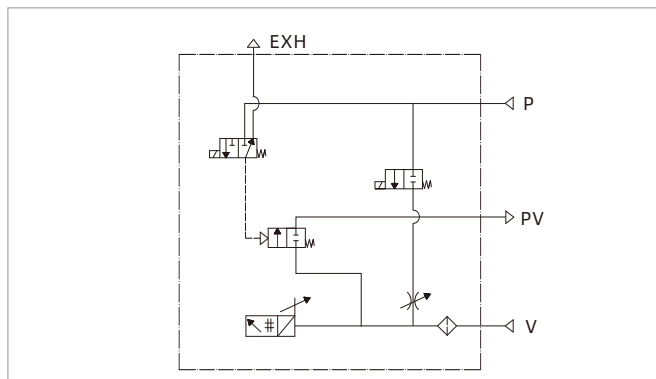

AZQ-B

### Repair kits

Item	Model	Remark
Solenoid valve leadwire	AZK-N	Plug lead wire length 300mm
Solenoid valve leadwire	AZK-3M	Plug lead wire length 3000mm
Solenoid valve	AZQ-I23	Vacuum solenoid valve
Solenoid valve	AZK-F23	Blow-off solenoid valve
Pressure switch	ZPDC-N	NPN output pressure gauge
Pressure switch	ZPDC-NE	NE(NPN output) pressure gauge
Pressure switch	ZPDC-P	PNP output pressure gauge
Pressure switch	ZPDC-PE	PE(PNP output) pressure gauge
Pressure switch power cord	ZPDC-CB	Pressure switch 5 core wires

# AZX Series

## Large Flow Integrated Vacuum Generator

**AIRBEST**



ELECTRONICS



PACKAGING



PLASTIC

### Features

- ◇ Energy-efficient nozzle design
- ◇ Integrated with control valve, vacuum gauge and regulating valve
- ◇ Modular design

### Advantages

- ◇ Large vacuum flow can be produced under the condition of low air consumption
- ◇ Integrated design, saving piping and wiring, controlling setting time, etc.
- ◇ High reliability and stability

### Applications

- ◇ Integrated vacuum generator for handling porous workpieces
- ◇ Vacuum producing and monitoring in automation systems
- ◇ For robot handling applications and linear axes
- ◇ Pick and place applications with very short time
- ◇ Used for systems that require high dynamic handling of workpieces and with limited space

### Structure

- ◇ (1) Vacuum supply valve
- ◇ (2) Vacuum release valve
- ◇ (3) Vacuum pressure switch
- ◇ (4) Release port
- ◇ (5) Air supply port
- ◇ (6) Vacuum port
- ◇ (7) Exhaust port
- ◇ (8) Mounting hole
- ◇ (9) Threaded mounting hole

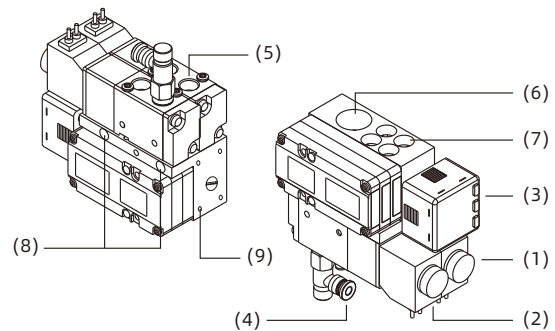
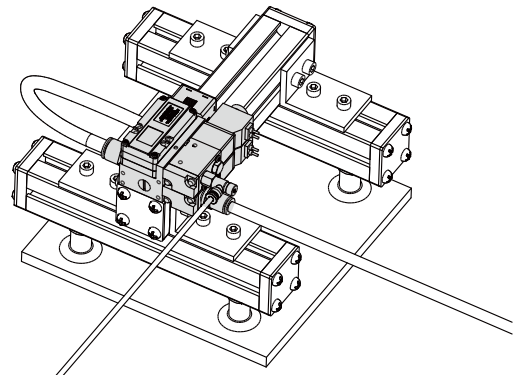

Vacuum Generator

AZK

AZQ

**AZX**

AZD

AGS

AGP

AGX

AGE

ABM/ABX

ABM/ABX  
Combined Type

AMC

AM/AL/AH

AM/AL  
Combined Type

AMD

AZW

AZR

ABT

ABP

ABQ

AEVC

AZL

ALH

AZH

AZU

ACV

ASBP

ALS

ACP

ACPF

ACPS

APB

### How to order

## AZX 20 - N

①      ②      ③

① Series	② Specification	③ Vacuum switch
AZX	20 30	N - 1NPN output+1 analog voltage output (1-5V) P - 1PNP output+1 analog voltage output (1-5V)

### Selection

Model/ Vacuum switch N	P
AZX20-N	AZX20-P
AZX30-N	AZX30-P

### Technical parameters

Model	Air supply pressure range bar	Max. vacuum level -kPa	Max. vacuum flow NL/min	Air consumption NL/min	Noise level dB(A)	Weight g	Recommended hose dia. mm	
							Air supply port P	Vacuum port V
AZX20	4.5~6.0	85	141~150	90~120	60~70	411	φ8	φ12
AZX30	4.5~6.0	85	175~220	130~160	60~70	424	φ10	φ12

### Vacuum flow(NL/min) at different vacuum levels(-kPa)

Model	Air supply pressure bar	Air consumption NL/min	Vacuum level (-kPa)										Max. vacuum level -kPa
			0	10	20	30	40	50	60	70	80		
AZX20	4.5	55	141	77	45	39.5	29.5	25	17.5	12	3	85	
AZX30	4.5	87	175	105	70	63	53	40	26	14	6.5	85	
AZX20	6.0	85	150	100	55	38	30	24	16	11	3.2	85	
AZX30	6.0	125	220	150	81	65	50	38	27	18	5	85	

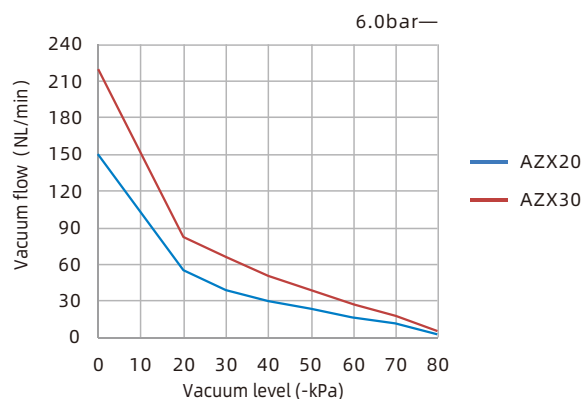
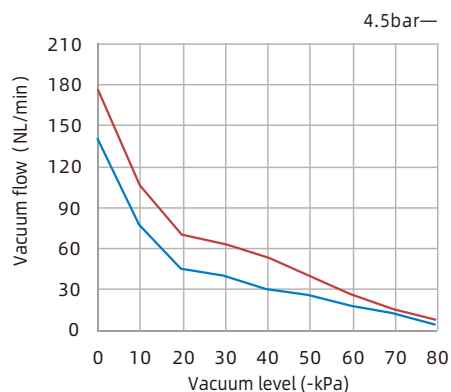

# AZX Series



## Large Flow Integrated Vacuum Generator

### Evacuation time(s/L) to reach different vacuum levels(-kPa)

Model	Air supply pressure bar	Air consumption NL/min	10	20	30	40	50	60	70	80	Max. vacuum level -kPa
AZX20	4.5	55	0.04	0.12	0.23	0.41	0.65	0.93	1.33	2.03	85
AZX30	4.5	87	0.03	0.09	0.16	0.27	0.43	0.66	0.95	1.43	85
AZX20	6.0	85	0.02	0.15	0.28	0.46	0.71	1.02	1.48	2.55	85
AZX30	6.0	125	0.02	0.08	0.14	0.31	0.49	0.69	1.02	1.75	85

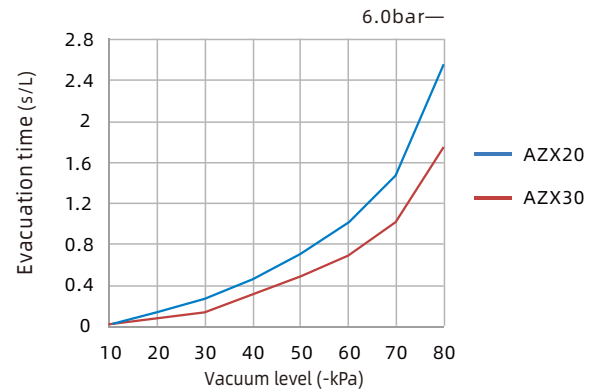
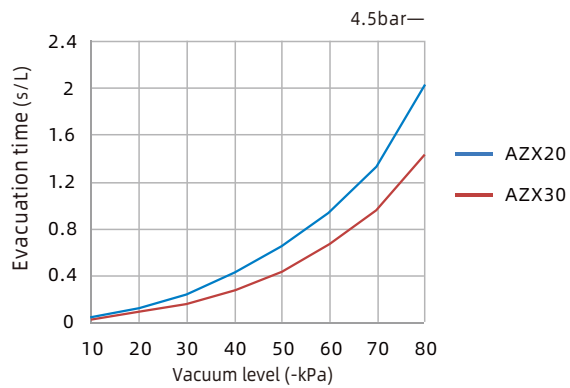

### Output circuit wiring diagrams

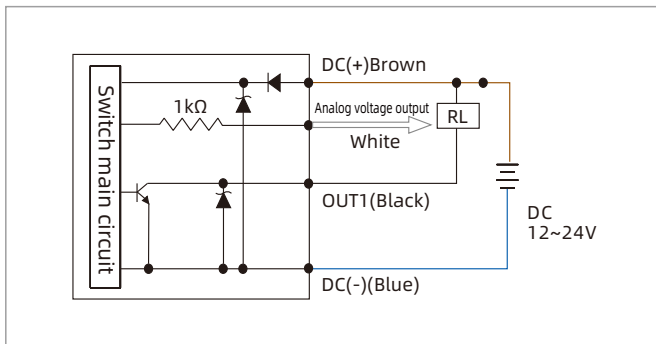

ZPDT-CNV-R1M 1NPN+Analog voltage output(1-5V)

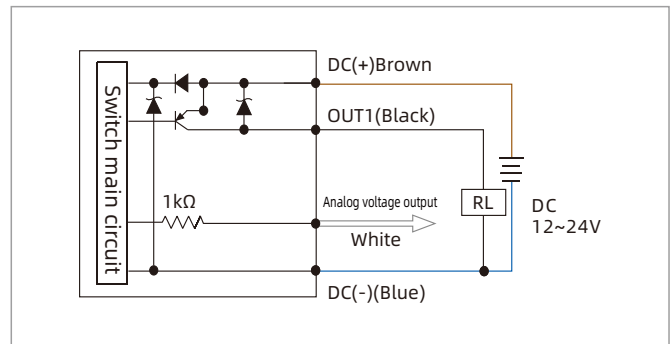

ZPDT-CPV-R1M 1PNP+Analog voltage output(1-5V)

Vacuum Generator

AZK

AZQ

AZX

AZD

AGS

AGP

AGX

AGE

ABM/ABX

ABM/ABX  
Combined Type

AMC

AM/AL/AH

AM/AL  
Combined Type

AMD

AZW

AZR

ABT

ABP

ABQ

AEVC

AZL

ALH

AZH

AZU

ACV

ASBP

ALS

ACP

ACPF

ACPS

APB

### Technical parameters

Model	ZPDT-C (Compound)	
Rated pressure range	-100.0~100.0kPa	
Setting pressure range	-103.0~103.0kPa	
Withstand pressure	500kPa	
Fluid	Air, Non-corrosive gas/Non-flammable gas	
Pressure unit	kPa	0.1
Set pressure resolution	MPa	-
	kgf/cm <sup>2</sup>	0.001
	bar	0.001
	psi	0.01
	inHg	0.1
	mmHg	1
Power supply voltage	12 to 24V Dc±10%, ripple(P-P)10% or less	
Current consumption	≤40mA (Without load)	
Switch output	Output type	Open collector output (NPN or PNP)
	load current	Max.125mA
	Residual voltage	≤1.0V
Analog output	Response time	≤2.5ms (Chattering-proof function: 25ms,100ms,250ms, 500ms, 1000ms, 1500ms selectable)
	Output Voltage	1-5V ±2.5%F.S (within rated pressure range)
	Output impedance	1kΩ
Display	Linearity	±1% F.S.
	Display	Three colors (Red/ Green/ Orange)Sampling rate:5 times/sec,2 times/sec,1 time/sec for choice.)
	Indicator accuracy	±1%F.S.±1 digit (ambient temperature: 25±3°C)
	Repeatability	±0.3%F.S.±1 digit
	Switch ON Indicator	Orange (1 indicator)OUT1
Environmental resistance	IP Grade	IP40
	Ambient temperature	0~50°C
	Temperature characteristic	±3% F.S. Comparative parameter temperature 25°C (at temp. range of 0~50°C)
	Storage temperature	Storage: -10-60°C (No condensation or freezing)
	Ambient temperature	Operation/ storage: 35-85%HR (No condensation)
Withstand voltage	1000VAC1 minute (between case and lead wire)	
Insulation resistance	More than 50MΩ (500V DC) (between case and lead wire)	
Vibration resistance	Complex amplitude 1.5mm Or 10G, 10Hz~150Hz~10Hz for 1 minute, two hours each direction of X, Y and Z	
Impact resistance	100m/s <sup>2</sup> (10G) 3 times each direction of X, Y and Z	
Lead wire	Oil-resistance cable (0.15mm <sup>2</sup> )	
Weight	67g (with 2 meters lead wire)	

# AZX Series

## Large Flow Integrated Vacuum Generator



### Dimensions(mm)

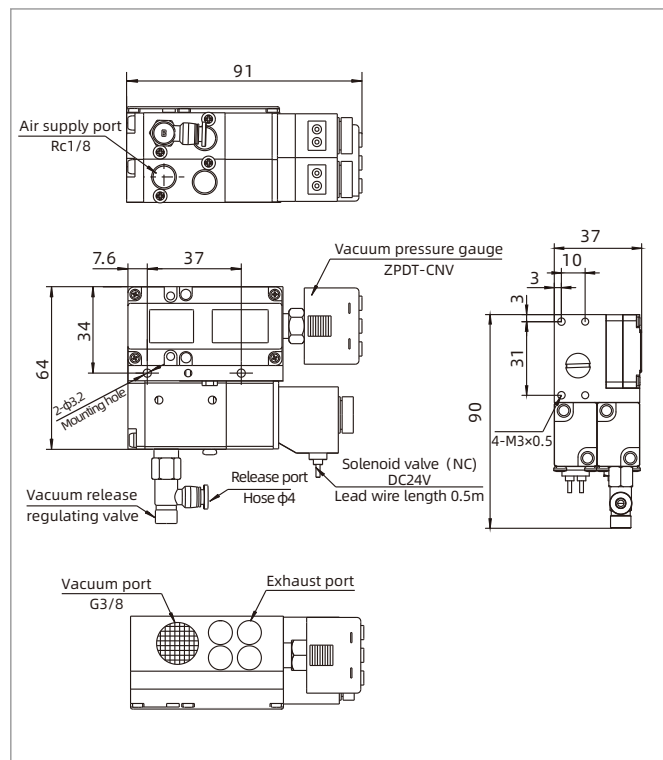

AZX20-N      AZX20-P

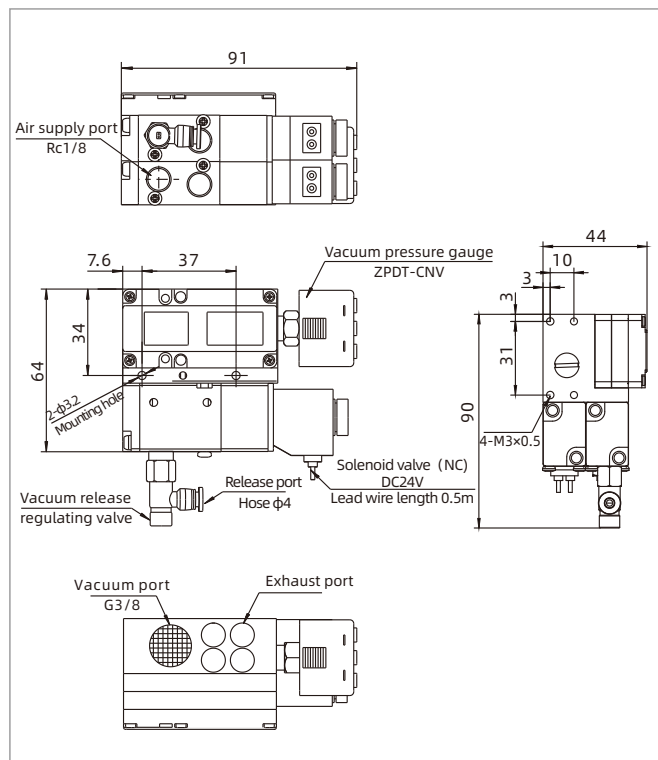

AZX30-N      AZX30-P

Vacuum Generator

AZK

AZQ

**AZX**

AZD

AGS

AGP

AGX

AGE

ABM/ABX

ABM/ABX  
Combined Type

AMC

AM/AL/AH

AM/AL  
Combined Type

AMD

AZW

AZR

ABT

ABP

ABQ

AEVC

AZL

ALH

AZH

AZU

ACV

ASBP

ALS

ACP

ACPF

ACPS

APB

# AZD Series

## Energy-saving Vacuum Generator

AIRBEST



UNIVERSAL



### Features

- ◇ Multistage vacuum generator with energy-efficient nozzle design
- ◇ Energy-saving function, it is integrated with vacuum unit, silencer, digital pressure gauge and vacuum energy saving control
- ◇ It has the function of debugging

### Advantages

- ◇ Large vacuum flow can be produced under the condition of low air consumption
- ◇ Easy to install, space saving, it can help customers to reduce cost most
- ◇ Customers can adjust and control the interval according to the actual application



### Applications

- ◇ Used in vacuum systems, where there are higher requirements for compressed air energy consumption occasions
- ◇ The vacuum generator is highly integrated with energy saving devices
- ◇ The energy-saving vacuum generator is suitable for the occasions where there is air leakage in the process of adsorption

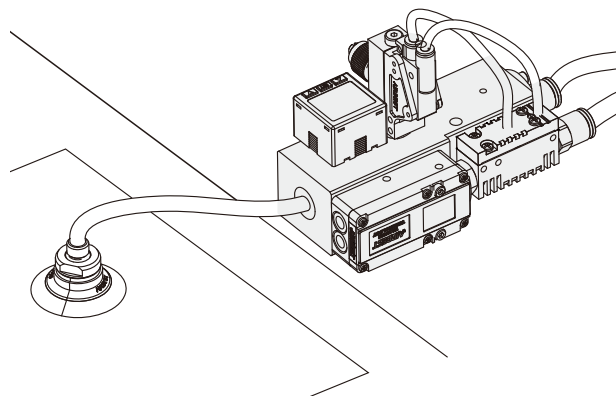

### Structure

- ◇ (1) Digital pressure gauge
- ◇ (2) Vacuum port
- ◇ (3) Vacuum generator
- ◇ (4) Adjusting screw
- ◇ (5) Mounting hole
- ◇ (6) Vacuum release port
- ◇ (7) Air supply port

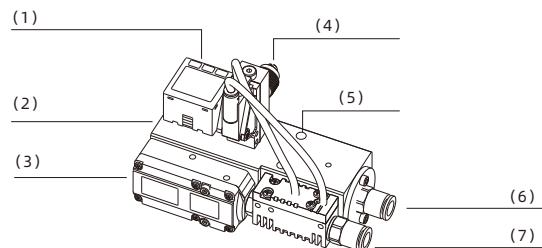

# AZD Series

## Energy-saving Vacuum Generator

### How to order

AZD 20 - ES - P  
 ①      ②      ③      ④

① Series	② Specification	③ Energy saving(ES) mode	④ Vacuum switch
AZD	20	ES - Pneumatic energy saving	Nil - 1NPN output+1 analog voltage output (1-5V) P - 1PNP output+1 analog voltage output (1-5V)

### Technical parameters

Model	Air supply pressure range bar	Rated air supply pressure bar	Max. vacuum level -kPa	Max. vacuum flow NL/min	Max. break flow rate NL/min
AZD20	4.0~7.0	5.0	83	90	52

Model	Air consumption NL/min	Noise level dB(A)	Working temperature °C	Weight g	Recommended hose dia.(mm) Air supply port P    Vacuum port V
AZD20	70	69	0~60	620	φ8      φ10

### Vacuum flow(NL/min) at different vacuum levels(-kPa)

Model	Air supply pressure bar	Air consumption NL/min	0	10	20	30	40	50	60	70	Max. vacuum level -kPa
AZD20	5.0	70	90	72	43	35	22	19	14	11	83

### Evacuation time(s/L) to reach different vacuum levels(-kPa)

Model	Air supply pressure bar	Air consumption NL/min	10	20	30	40	50	60	70	Max. vacuum level -kPa
AZD20	5.0	70	0.08	0.2	0.39	0.63	0.99	1.5	4.15	83

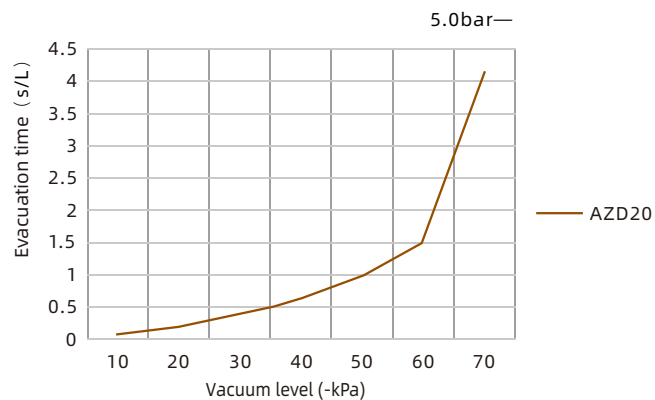
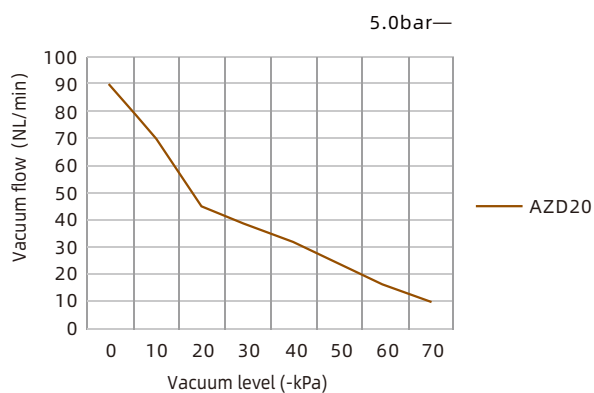

# AZD Series

## Energy-saving Vacuum Generator

### Dimensions(mm)

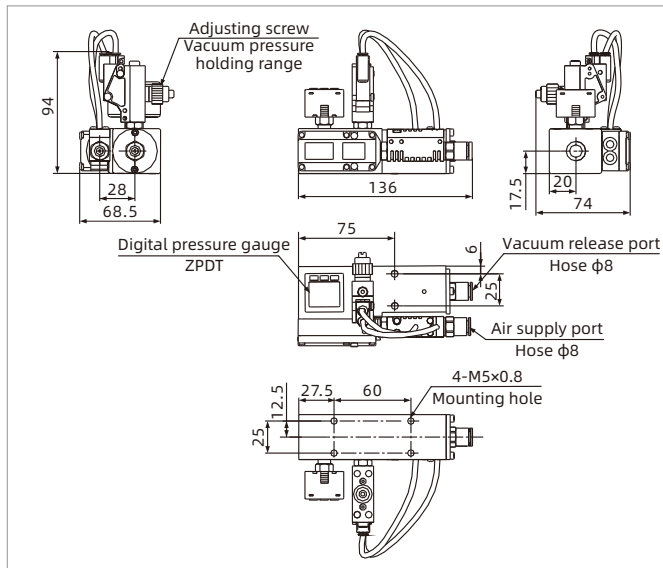

AZD20-ES

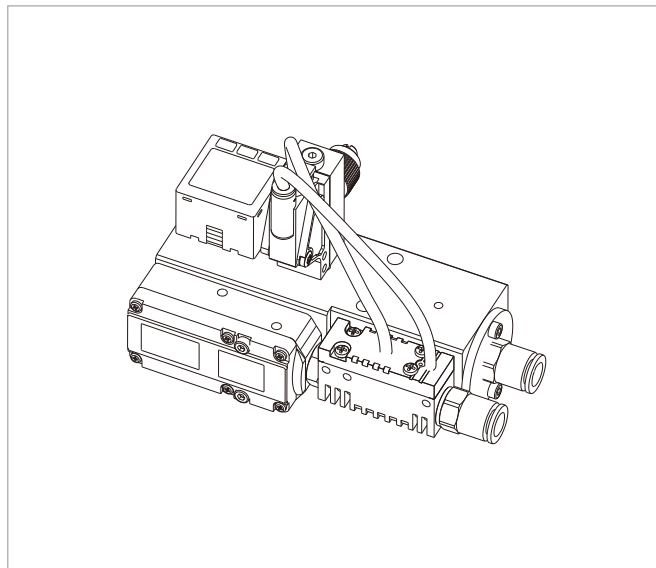

AZD20-ES Schematic diagram

# AGS Series

## Vacuum Generator

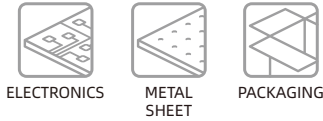

### Features

- ◇ Fast suction, high vacuum degree, low air consumption
- ◇ The workpiece can be of airtight or porous material
- ◇ Dirt and dust resistance
- ◇ Small size, light weight, simple structure
- ◇ External silencer is optional

### Advantages

- ◇ High efficient and energy-saving vacuum generator, it can reach the max. vacuum level quickly, effectively compensate air leakage
- ◇ Suitable vacuum generators can be selected according to different working conditions
- ◇ Long maintenance time, simple cleaning, no need tools
- ◇ Can be used in occasions with limited space and weight, easy to install
- ◇ Reduce product noise most



### Applications

- ◇ The multistage vacuum generator is suitable for handling cartons, packaging materials and porous materials
- ◇ Applicable to the working conditions that require high vacuum flow, fast evacuation and low air consumption

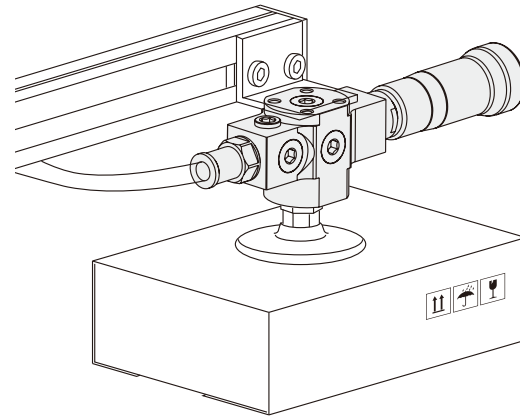

### Structure

- ◇ (1) Housing
- ◇ (2) Vacuum cartridge
- ◇ (3) Air supply port

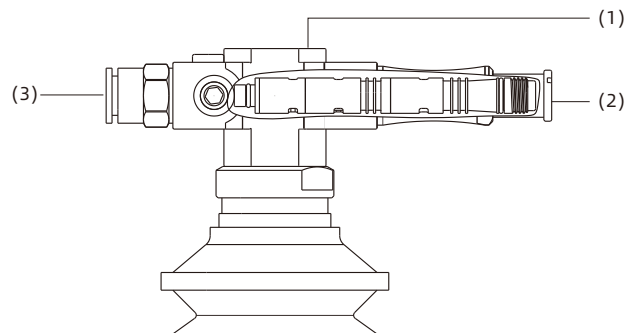

Vacuum Generator

AZK

AZQ

AZX

AZD

**AGS**

AGP

AGX

AGE

ABM/ABX

ABM/ABX  
Combined Type

AMC

AM/AL/AH

AM/AL  
Combined Type

AMD

AZW

AZR

ABT

ABP

ABQ

AEVC

AZL

ALH

AZH

AZU

ACV

ASBP

ALS

ACP

ACPF

ACPS

APB

# AGS Series

## Vacuum Generator

### How to order

AGS - N - S08-2 - V - S  
 ①            ②            ③            ④            ⑤

① Series	② Housing type	③ Specification	④ Non-return valve	⑤ Silencer
AGS	C (MICRO)	S02 - 2 X2.5 - 2 T05 - 2	Nil - Without non-return valve	Nil - Without silencer
	N (MINI)	S08 - 2 S08 - 3 X10 - 2 X10 - 3 P12 - 2 P12 - 3 D16 - 2	Nil - Without non-return valve V - With non-return valve	Nil - Without silencer S - With silencer ZSC8
	D (MIDI)	S32 - 2 S32 - 3 X40 - 2 X40 - 3	Nil - Without non-return valve V - With non-return valve	Nil - Without silencer S - With silencer ZSC16

### Selection

Model/Non-return valve selection Nil - Without non-return valve		V - With non-return valve	
AGS-C-S02-2		-	
AGS-C-X2.5-2		-	
AGS-C-T05-2		-	
AGS-N-S08-2	AGS-N-S08-2-S	AGS-N-S08-2-V	AGS-N-S08-2-V-S
AGS-N-S08-3	AGS-N-S08-3-S	AGS-N-S08-3-V	AGS-N-S08-3-V-S
AGS-N-X10-2	AGS-N-X10-2-S	AGS-N-X10-2-V	AGS-N-X10-2-V-S
AGS-N-X10-3	AGS-N-X10-3-S	AGS-N-X10-3-V	AGS-N-X10-3-V-S
AGS-N-P12-2	AGS-N-P12-2-S	AGS-N-P12-2-V	AGS-N-P12-2-V-S
AGS-N-P12-3	AGS-N-P12-3-S	AGS-N-P12-3-V	AGS-N-P12-3-V-S
AGS-N-D16-2	AGS-N-D16-2-S	-	-
AGS-D-S32-2	AGS-D-S32-2-S	AGS-D-S32-2-V	AGS-D-S32-2-V-S
AGS-D-S32-3	AGS-D-S32-3-S	AGS-D-S32-3-V	AGS-D-S32-3-V-S
AGS-D-X40-2	AGS-D-X40-2-S	AGS-D-X40-2-V	AGS-D-X40-2-V-S
AGS-D-X40-3	AGS-D-X40-3-S	AGS-D-X40-3-V	AGS-D-X40-3-V-S

◇ Note: The mounting accessories are ordered separately except the default specification

# AGS-C Series

## Vacuum Generator

### Features

- ◇ Small size, simple structure, easy to install
- ◇ Vacuum port G1/8 female thread can be directly connected to the suction cup
- ◇ A variety of vacuum cartridges can be freely selected, suitable for different applications
- ◇ Multi-angle installation position and installation accessories are available for convenient installation



### Technical parameters

Model	Air supply pressure range bar	Max. vacuum level -kPa	Max. vacuum flow NL/min	Air consumption NL/min	Noise level dB(A)	Weight g	Recommended hose dia.(mm)	
							Air supply port	Vacuum port
AGS-C-S02-2	4.0~6.0	75	16.2	8.0	70	34	φ4	G1/8
AGS-C-X2.5-2	4.5~6.0	90	17.2	10.5	72	34	φ4	G1/8
AGS-C-T05-2	4.0~6.0	84	19.5	21.5	78	34	φ4	G1/8

### Vacuum flow(NL/min) at different vacuum levels(-kPa)

Model	Air supply pressure bar	Air consumption NL/min	Vacuum level (-kPa)									Max. vacuum level -kPa
			0	10	20	30	40	50	60	70		
AGS-C-S02-2	4.0	6.0	14.2	8.1	5.2	3.8	2.2	-	-	-	55	
	5.0	7.0	15.7	10.0	5.5	4.5	3.4	2.2	-	-	70	
	6.0	8.0	16.2	12.2	6.3	4.6	3.9	3.0	2.0	-	75	
AGS-C-X2.5-2	4.5	9.0	14.9	9.9	4.8	4.1	3.3	2.6	1.7	-	85	
	5.0	9.5	15.6	11.6	6.6	4.0	3.3	2.6	1.7	-	90	
	6.0	10.0	17.2	14.2	9.3	4.5	3.3	2.3	1.4	-	89	
AGS-C-T05-2	4.0	16.0	19.5	17.7	13.5	9.0	6.1	5.0	3.3	1.8	84	
	6.0	21.5	18.7	17.4	15.1	13.1	9.7	6.0	2.7	1.8	75	

### Evacuation time(s/L) to reach different vacuum levels(-kPa)

Model	Air supply pressure bar	Air consumption NL/min	Vacuum level (-kPa)								Max. vacuum level -kPa
			10	20	30	40	50	60	70	80	
AGS-C-S02-2	4.0	6.0	0.4	1.4	2.8	5.1	-	-	-	-	55
	5.0	7.0	0.3	1.2	2.5	4.1	6.6	11.1	-	-	70
	6.0	8.0	0.3	1.1	2.4	4.1	6.2	9.0	14.3	-	75
AGS-C-X2.5-2	4.5	9.0	0.4	1.3	3.2	4.6	6.5	9.8	15.3	25.70	85
	5.0	9.5	0.3	0.9	2.4	4.3	6.7	9.5	14.1	22.03	90
	6.0	10.0	0.2	0.7	1.7	3.7	5.9	9.5	14.5	22.41	89
AGS-C-T05-2	4.0	16.0	0.2	0.5	1.1	2.2	3.4	5.2	9.0	17.36	84
	6.0	21.5	0.2	0.5	0.9	1.5	2.6	4.7	7.7	16.09	75

# AGS-C Series

## Vacuum Generator

### Dimensions(mm)

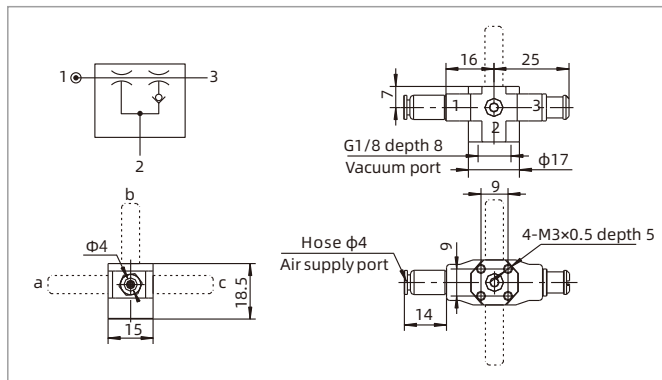

### Mounting accessory(mm)

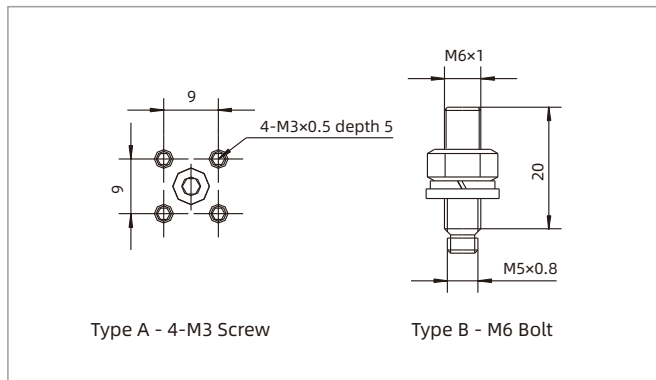

AGS-C

◇ Note: Type B is optional for above drawing a/b/c. Default mounting accessory is type A for AGS-C series

# AGS-N Series

## Vacuum Generator

### Features

- ◇ Small size, simple structure, easy to install
- ◇ Vacuum port G3/8 female thread can be directly connected to the suction cup
- ◇ A variety of vacuum cartridges can be freely selected, suitable for different applications
- ◇ Multi-angle installation position and installation accessories are available for convenient installation
- ◇ Exhaust port can be connected with external silencer



### Technical parameters

Model	Air supply pressure range bar	Max. vacuum level -kPa	Max. vacuum flow NL/min	Air consumption NL/min	Noise level dB(A)	Weight g	Recommended hose dia.(mm)	
							Air supply port	Vacuum port
AGS-N-S08-2	4.0~6.0	75	46	27	62	61	φ6	G3/8
AGS-N-S08-3	4.0~6.0	75	68	27	68	65	φ6	G3/8
AGS-N-X10-2	4.5~6.0	93	44	34	78	61	φ6	G3/8
AGS-N-X10-3	4.5~6.0	93	68	34	74	65	φ6	G3/8
AGS-N-P12-2	1.7~4.0	90	42	33	68	61	φ6	G3/8
AGS-N-P12-3	1.7~4.0	90	68	33	71	65	φ6	G3/8
AGS-N-D16-2	6.0	72	40	46	77	61	φ6	G3/8

### Vacuum flow(NL/min) at different vacuum levels(-kPa)

Model	Air supply pressure bar	Air consumption NL/min	Vacuum level (-kPa)										Max. vacuum level -kPa
			0	10	20	30	40	50	60	70	80		
AGS-N-S08-2	4.0	19.0	44.0	34.0	22.6	14.4	10.8	6.4	-	-	-	60	
	5.0	23.0	46.0	40.0	28.5	17.3	12.8	9.5	6.1	-	-	70	
	6.0	27.0	46.0	42.0	32.6	22.6	12.0	9.8	8.3	5.9	-	75	
AGS-N-S08-3	4.0	19.0	60.0	38.0	24.0	14.9	11.5	6.8	-	-	-	60	
	5.0	23.0	66.0	40.0	32.0	19.1	13.3	9.9	6.5	-	-	70	
	6.0	27.0	68.0	42.0	36.0	24.0	13.0	10.2	8.4	6.3	-	75	
AGS-N-X10-2	4.5	27.5	44.0	40.0	28.4	18.8	10.7	9.4	6.9	4.6	2.3	90	
	5.0	30.0	44.0	40.0	30.6	22.2	13.5	8.9	6.6	4.5	2.0	93	
	6.0	34.5	42.0	40.0	33.0	26.9	18.7	9.4	6.2	4.6	1.4	91	
AGS-N-X10-3	4.5	27.5	64.0	40.0	32.0	18.0	11.3	9.7	7.3	4.9	2.7	90	
	5.0	30.0	66.0	40.0	34.0	24.0	14.3	9.3	6.9	4.8	2.4	93	
	6.0	34.5	68.0	44.0	34.0	30.0	20.0	10.5	6.5	4.9	1.7	91	
AGS-N-P12-2	1.7	19.0	36.0	19.0	10.5	6.6	2.8	-	-	-	-	43	
	2.2	22.5	38.0	28.0	15.5	11.0	7.7	3.8	-	-	-	58	
	3.14	29.0	42.0	36.0	25.6	14.9	10.4	8.9	6.6	4.2	1.9	90	
AGS-N-P12-3	4.0	35.0	42.0	38.0	30.0	23.0	15.0	8.0	5.9	4.3	1.1	88	
	1.7	19.0	46.0	19.8	10.5	7.0	3.0	-	-	-	-	43	
	2.2	22.5	52.0	30.0	12.0	8.2	5.8	2.7	-	-	-	58	
AGS-N-D16-2	3.14	29.0	62.0	38.0	28.0	10.0	7.7	6.7	4.8	2.9	1.4	90	
	4.0	35.0	68.0	40.0	34.0	24.0	11.4	5.7	4.2	3.0	1.2	88	
	6.0	46.0	40.0	38.0	30.5	26.7	22.0	17.0	12.0	3.5	-	72	

# AGS-N Series

## Vacuum Generator

### Evacuation time(s/L) to reach different vacuum levels(-kPa)

Model	Air supply pressure bar	Air consumption NL/min	10	20	30	40	50	60	70	80	Max. vacuum level -kPa
AGS-N-S08-2	4.0	19.0	0.07	0.25	0.56	1.02	1.89	5.24	-	-	60
	5.0	23.0	0.07	0.22	0.47	0.85	1.53	2.40	6.43	-	70
	6.0	27.0	0.07	0.20	0.39	0.74	1.35	2.14	3.35	-	75
AGS-N-S08-3	4.0	19.0	0.06	0.22	0.53	0.93	1.72	4.61	-	-	60
	5.0	23.0	0.06	0.19	0.44	0.83	1.35	2.23	6.33	-	70
	6.0	27.0	0.05	0.19	0.38	0.68	1.26	2.08	3.05	-	75
AGS-N-X10-2	4.5	27.5	0.11	0.27	0.52	0.98	1.65	2.41	3.87	6.20	90
	5.0	30.0	0.12	0.27	0.48	0.83	1.49	2.49	3.77	6.19	93
	6.0	34.5	0.12	0.26	0.45	0.72	1.21	2.33	3.68	6.35	91
AGS-N-X10-3	4.5	27.5	0.06	0.19	0.40	0.76	1.45	2.21	3.49	5.55	90
	5.0	30.0	0.05	0.19	0.37	0.66	1.26	2.14	3.45	5.60	93
	6.0	34.5	0.05	0.18	0.35	0.59	1.02	2.10	3.31	5.72	91
AGS-N-P12-2	1.7	19.0	0.15	0.55	1.26	2.90	-	-	-	-	43
	2.2	22.5	0.14	0.37	0.88	1.58	2.78	-	-	-	58
	3.14	29.0	0.12	0.29	0.59	1.07	1.86	2.66	4.33	6.72	90
	4.0	35.0	0.12	0.26	0.49	0.77	1.50	2.48	3.98	7.05	88
AGS-N-P12-3	1.7	19.0	0.13	0.52	1.22	2.75	-	-	-	-	43
	2.2	22.5	0.08	0.31	0.70	1.33	2.54	-	-	-	58
	3.14	29.0	0.06	0.21	0.45	0.94	1.58	2.40	3.83	6.07	90
	4.0	35.0	0.06	0.20	0.38	0.67	1.26	2.36	3.75	6.57	88
AGS-N-D16-2	6.0	46.0	0.04	0.18	0.39	0.62	0.95	1.47	3.10	-	72

### Dimensions(mm)

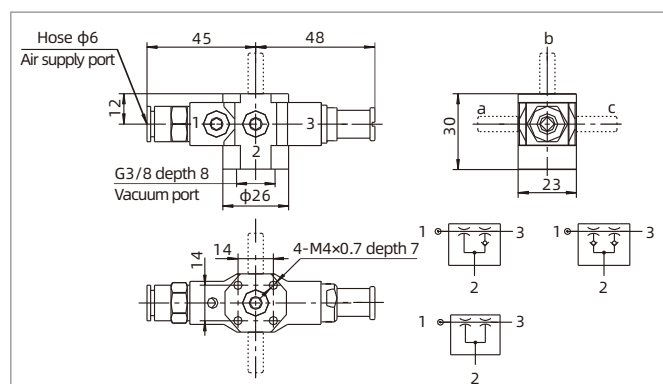

AGS-N (MINI type 2 stages)

◇ Note: Type D/E are optional for above drawing a/b/c. Default mounting accessory is type C for AGS-N series

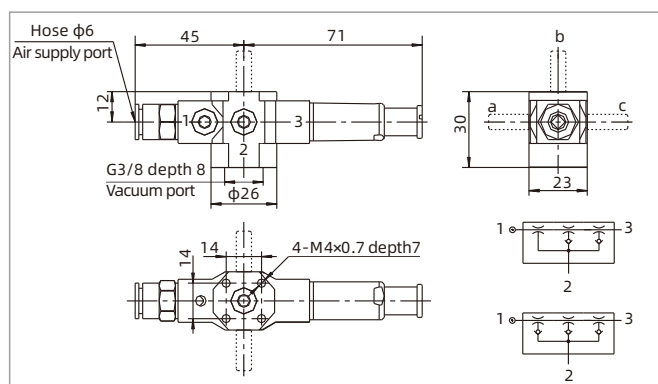

AGS-N (MINI type 3 stages)

### Model selection

Housing	Vacuum cartridge
MINI type 2 stages	S08-2, X10-2, P12-2, D16-2
MINI type 3 stages	S08-3, X10-3, P12-3

# AGS-N Series

## Vacuum Generator

### Mounting accessory(mm)

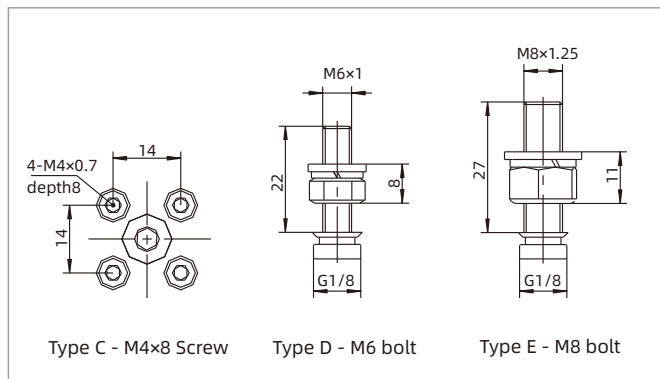

### Silencer(mm)

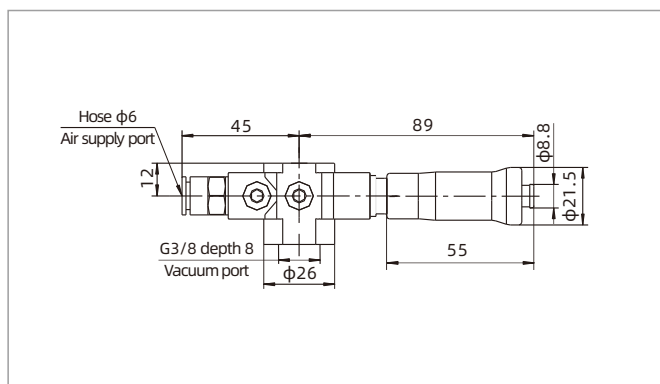

MINI type 2 stages

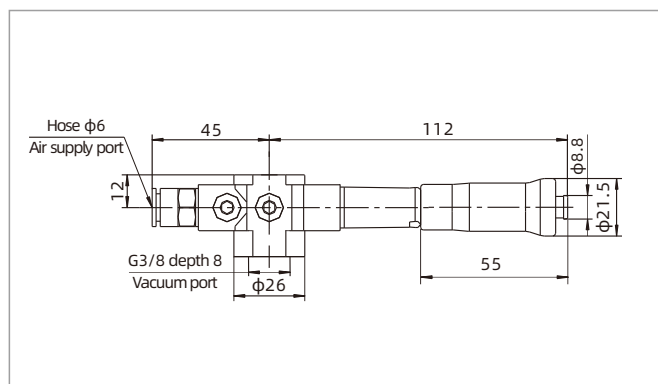

MINI type 3 stages

Housing	Silencer
MINI type 2 stages	ZSC8
MINI type 3 stages	ZSC8

Model	Working pressure range Mpa	Ambient temperature and fluid temperature °C	Noise reduction dB(A)
ZSC8	0.1~0.6	2~50	10

◇Note: The noise reduction value is a test value under laboratory environmental conditions (not a guaranteed value).

# AGS-D Series

## Vacuum Generator

### Features

- ◇ Small size, simple structure, easy to install
- ◇ Vacuum port G1/2 female thread can be directly connected to the suction cup
- ◇ A variety of vacuum cartridges can be freely selected, suitable for different applications
- ◇ Multi-angle installation position and installation accessories are available for convenient installation
- ◇ Suitable for occasions requiring large vacuum flow
- ◇ Exhaust port can be connected with external silencer



### Technical parameters

Model	Air supply pressure range bar	Max. vacuum level -kPa	Max. vacuum flow NL/min	Air consumption NL/min	Noise level dB(A)	Weight g	Recommended hose dia.(mm)	
							Air supply port	Vacuum port
AGS-D-S32-2	4.0~6.0	75	178.0	130.0	82	259	φ8	G1/2
AGS-D-S32-3	4.0~6.0	75	360.0	130.0	82	272	φ8	G1/2
AGS-D-X40-2	4.5~6.0	95	170.0	135.0	89	259	φ8	G1/2
AGS-D-X40-3	4.5~6.0	95	372.0	135.0	89	272	φ8	G1/2

### Vacuum flow(NL/min) at different vacuum levels(-kPa)

Model	Air supply pressure bar	Air consumption NL/min	Vacuum level (-kPa)										Max. vacuum level -kPa
			0	10	20	30	40	50	60	70	80	90	
AGS-D-S32-2	4.0	120	172	136	92	60	44	26.2	10.5	-	-	-	60
	5.0	125	180	156	116	72	48	36.0	26.9	12.8	-	-	70
	6.0	130	178	164	134	94	50	38.0	32.0	18.3	-	-	75
AGS-D-S32-3	4.0	120	350	152	110	64	50	26.7	11.5	-	-	-	60
	5.0	125	370	185	125	90	50	36.2	27.3	13.9	-	-	70
	6.0	130	390	210	135	100	65	35.1	30.3	18.3	-	-	75
AGS-D-X40-2	4.5	120	170	136	100	58	40	36.0	25.0	17.8	11.7	3.1	91
	5.0	125	170	140	106	74	46	34.0	24.0	17.6	10.8	2.9	95
	6.0	135	162	142	116	92	68	40.0	22.5	17.8	9.4	2.3	94
AGS-D-X40-3	4.5	120	350	175	120	80	44	32.7	24.5	17.8	11.6	3.2	91
	5.0	125	360	190	125	95	65	36.0	26.0	17.6	10.8	2.8	95
	6.0	135	380	220	130	105	90	54.0	26.0	17.8	9.3	2.2	94

### Evacuation time(s/L) to reach different vacuum levels(-kPa)

Model	Air supply pressure bar	Air consumption NL/min	Vacuum level (-kPa)							Max. vacuum level -kPa
			10	20	30	40	50	60	70	
AGS-D-S32-2	4.0	120	0.04	0.08	0.16	0.27	0.47	0.98	-	60
	5.0	125	0.04	0.08	0.14	0.25	0.39	0.63	1.17	70
	6.0	130	0.04	0.08	0.13	0.21	0.36	0.55	0.86	75
AGS-D-S32-3	4.0	120	0.03	0.08	0.15	0.26	0.44	0.94	-	60
	5.0	125	0.03	0.07	0.13	0.23	0.38	0.61	1.07	70
	6.0	130	0.03	0.05	0.10	0.18	0.36	0.56	0.87	75

# AGS-D Series

## Vacuum Generator



### Evacuation time(s/L) to reach different vacuum levels(-kPa)

Model	Air supply pressure bar	Air consumption NL/min	10	20	30	40	50	60	70	80	90	Max. vacuum level -kPa
AGS-D-X40-2	4.5	120	0.04	0.08	0.15	0.28	0.46	0.66	0.99	1.15	-	91
	5.0	125	0.04	0.08	0.14	0.24	0.41	0.66	1.02	1.52	3.27	95
	6.0	135	0.04	0.08	0.14	0.20	0.30	0.57	0.95	1.55	3.70	94
AGS-D-X40-3	4.5	120	0.03	0.07	0.13	0.23	0.38	0.63	0.97	1.50	3.25	91
	5.0	125	0.03	0.07	0.14	0.21	0.37	0.62	0.99	1.46	3.23	95
	6.0	135	0.03	0.05	0.10	0.16	0.27	0.47	0.86	1.45	3.92	94

### Dimensions(mm)

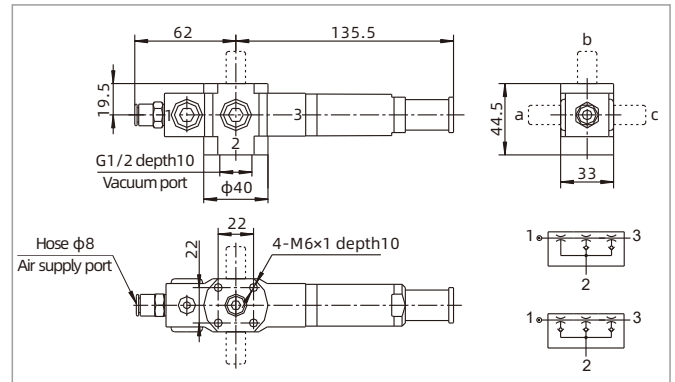
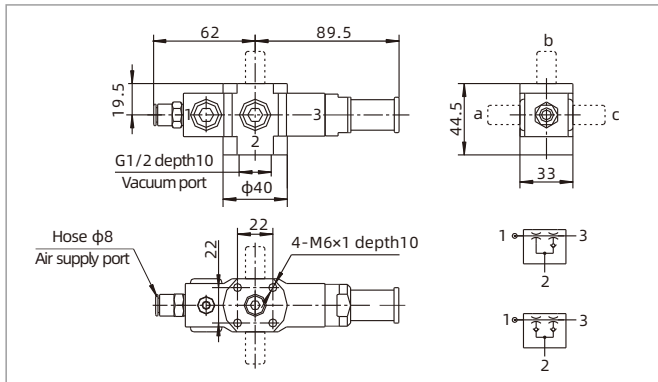

AGS-D (MIDI type 2 stages)

AGS-D (MIDI type 3 stages)

◇ Note: Type G/H/K are optional for above drawing a/b/c. Default mounting accessory is type F for AGS-D series

### Model selection

Housing	Vacuum cartridge
MIDI type 2 stages	S32-2, X40-2
MIDI type 3 stages	S32-3, X40-3

### Mounting accessory(mm)

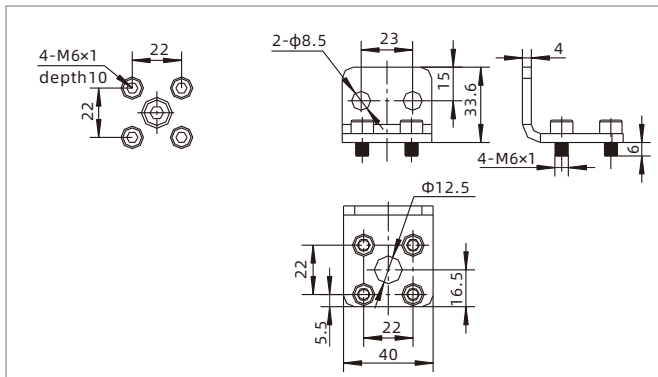

Type F - M6 Screw

Type G - M6 Screw + L type bracket

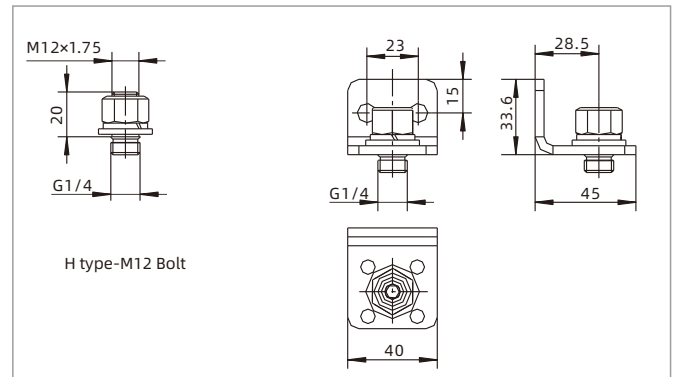

Type H - M12 Bolt

Type K - M12 Bolt + L type bracket

Vacuum Generator

AZK

AZQ

AZX

AZD

AGS

AGP

AGX

AGE

ABM/ABX

ABM/ABX Combined Type

AMC

AM/AL/AH

AM/AL Combined Type

AMD

AZW

AZR

ABT

ABP

ABQ

AEVC

AZL

ALH

AZH

AZU

ACV

ASBP

ALS

ACP

ACPF

ACPS

APB

# AGS-D Series

## Vacuum Generator

### Silencer(mm)

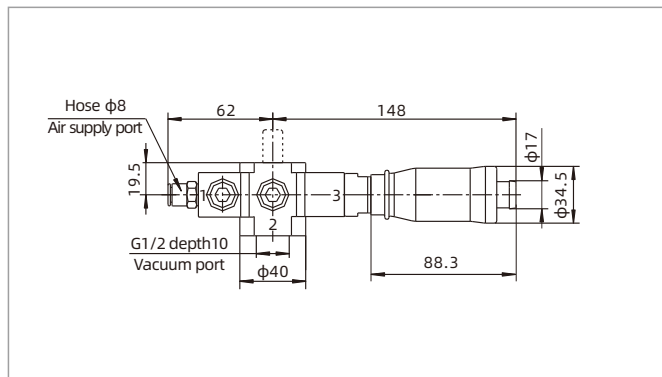

MIDI type 2 stages

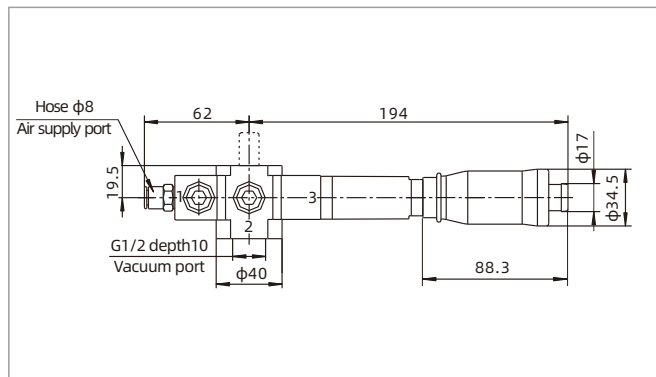

MIDI type 3 stages

Housing	Silencer
MIDI type 2 stages	ZSC16
MIDI type 3 stages	ZSC16

Model	Working pressure range Mpa	Ambient temperature and fluid temperature °C	Noise reduction dB(A)
ZSC16	0.1~0.6	2~50	10

◇Note: The noise reduction value is a test value under laboratory environmental conditions (not a guaranteed value).

# AGP Series

## Vacuum Generator



ELECTRONICS



METAL SHEET



PACKAGING

### Features

- ◇ Fast evacuation, high vacuum level, low air consumption
- ◇ Built-in vacuum cartridge
- ◇ Small size, simple structure, groove type installation structure
- ◇ There are 6 vacuum ports with G1/8 female thread

### Advantages

- ◇ High efficient and energy-saving vacuum generator, can quickly reach the max. vacuum level
- ◇ The suitable vacuum generators can be selected according to different working conditions
- ◇ Simple installation structure, can be installed quickly
- ◇ Multiple suction cups can be connected at the same time
- ◇ Reduce product noise



### Applications

- ◇ The working conditions where multiple suction cups are directly installed at the same time
- ◇ Applicable to the working conditions that require fast evacuation and low air consumption

### Structure

- ◇ Housing can be freely matched with vacuum cartridges with different performance parameters
- ◇ The air supply port is directly inserted into the φ6 hose, the vacuum port is G1/8 female thread

### How to order

**AGP - S08-3**  
 ①                      ②

① Series	② Specification
AGP	S08-3 (-75kPa) X10-3 (-93kPa) P12-3 (-90kPa)

Vacuum Generator

AZK

AZQ

AZX

AZD

AGS

**AGP**

AGX

AGE

ABM/ABX

ABM/ABX  
Combined Type

AMC

AM/AL/AH

AM/AL  
Combined Type

AMD

AZW

AZR

ABT

ABP

ABQ

AEVC

AZL

ALH

AZH

AZU

ACV

ASBP

ALS

ACP

ACPF

ACPS

APB

# AGP Series

## Vacuum Generator

### Vacuum flow(NL/min) at different vacuum levels(-kPa)

Model	Air supply pressure bar	Air consumption NL/min	0	10	20	30	40	50	60	70	80	Max. vacuum level -kPa
AGP-S08-3	4.0	19.0	60.0	38.0	24.0	14.9	11.5	6.8	-	-	-	60
	5.0	23.0	66.0	40.0	32.0	19.1	13.3	9.9	6.5	-	-	70
	6.0	27.0	68.0	42.0	36.0	24.0	13.0	10.2	8.4	6.3	-	75
AGP-X10-3	4.5	27.5	64.0	40.0	32.0	18.0	11.3	9.7	7.3	4.9	2.7	90
	5.0	30.0	66.0	40.0	34.0	24.0	14.3	9.3	6.9	4.8	2.4	93
	6.0	34.5	68.0	44.0	34.0	30.0	20.0	10.5	6.5	4.9	1.7	91
AGP-P12-3	1.7	19.0	46.0	19.8	10.5	7.0	3.0	-	-	-	-	43
	2.2	22.5	52.0	30.0	12.0	8.2	5.8	2.7	-	-	-	58
	3.14	29.0	62.0	38.0	28.0	10.0	7.7	6.7	4.8	2.9	1.4	90
	4.0	35.0	68.0	40.0	34.0	24.0	11.4	5.7	4.2	3.0	1.2	88

### Evacuation time(s/L) to reach different vacuum levels(-kPa)

Model	Air supply pressure bar	Air consumption NL/min	10	20	30	40	50	60	70	80	Max. vacuum level -kPa
AGP-S08-3	4.0	19.0	0.06	0.22	0.53	0.93	1.72	4.61	-	-	60
	5.0	23.0	0.06	0.19	0.44	0.83	1.35	2.23	6.33	-	70
	6.0	27.0	0.05	0.19	0.38	0.68	1.26	2.08	3.05	-	75
AGP-X10-3	4.5	27.5	0.06	0.19	0.40	0.76	1.45	2.21	3.49	5.55	90
	5.0	30.0	0.05	0.19	0.37	0.66	1.26	2.14	3.45	5.60	93
	6.0	34.5	0.05	0.18	0.35	0.59	1.02	2.10	3.31	5.72	91
AGP-P12-3	1.7	19.0	0.13	0.52	1.22	2.75	-	-	-	-	43
	2.2	22.5	0.08	0.31	0.70	1.33	2.54	-	-	-	58
	3.14	29.0	0.06	0.21	0.45	0.94	1.58	2.40	3.83	6.07	90
	4.0	35.0	0.06	0.20	0.38	0.67	1.26	2.36	3.75	6.57	88

### Dimensions(mm)

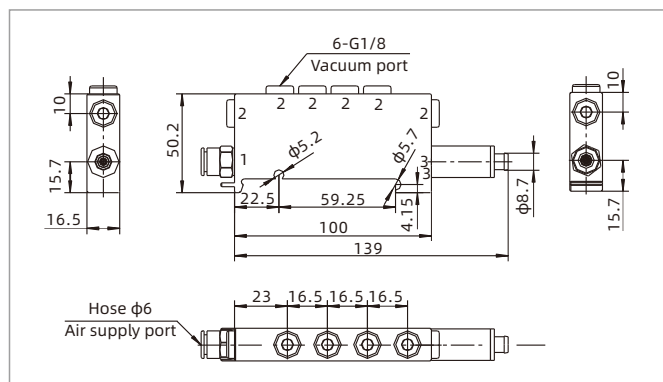

AGP

### AGP Air circuit schematic diagram

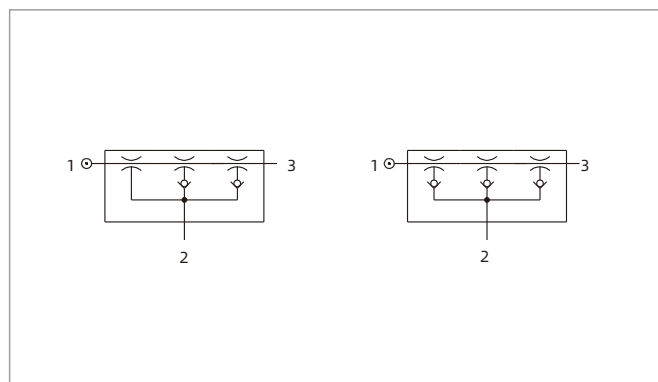

◇ Note: 1. Air supply port, 2. Vacuum port, 3. Exhaust port

# AGX Series

## Vacuum Generator



ELECTRONICS



METAL SHEET



PACKAGING

### Features

- ◇ Fast evacuation, high vacuum level, low air consumption
- ◇ Built-in vacuum cartridge
- ◇ Small size, simple structure, groove type installation structure
- ◇ There are 6 vacuum ports with G1/4 female thread

### Advantages

- ◇ High efficient and energy-saving vacuum generator, can quickly reach the max. vacuum level
- ◇ The suitable vacuum generators can be selected according to different working conditions
- ◇ Simple installation structure, can be installed quickly
- ◇ Multiple suction cups can be connected at the same time
- ◇ Reduce product noise



### Applications

- ◇ The working conditions where multiple suction cups are directly installed at the same time
- ◇ Applicable to the working conditions that require fast evacuation and low air consumption

### Structure

- ◇ Housing can be freely matched with vacuum cartridges with different performance parameters
- ◇ The air supply port is directly inserted into the φ8 hose, the vacuum port is G1/4 female thread

### How to order

## AGX - S32-3

①                      ②

① Series	② Specification
AGX	S32-3 (-75kPa) X40-3 (-95kPa)

Vacuum Generator

AZK

AZQ

AZX

AZD

AGS

AGP

**AGX**

AGE

ABM/ABX

ABM/ABX  
Combined Type

AMC

AM/AL/AH

AM/AL  
Combined Type

AMD

AZW

AZR

ABT

ABP

ABQ

AEVC

AZL

ALH

AZH

AZU

ACV

ASBP

ALS

ACP

ACPF

ACPS

APB

# AGX Series

## Vacuum Generator

### Vacuum flow(NL/min) at different vacuum levels(-kPa)

Model	Air supply pressure bar	Air consumption NL/min	0	10	20	30	40	50	60	70	80	90	Max. vacuum level -kPa
AGX-S32-3	4.0	120	350	152	110	64	50	26.7	11.5	-	-	-	60
	5.0	125	370	185	125	90	50	36.2	27.3	13.9	-	-	70
	6.0	130	390	210	135	100	65	35.1	30.3	18.3	-	-	75
AGX-X40-3	4.5	120	350	175	120	80	44	32.7	24.5	17.8	11.6	3.2	91
	5.0	125	360	190	125	95	65	36.0	26.0	17.6	10.8	2.8	95
	6.0	135	380	220	130	105	90	54.0	26.0	17.8	9.3	2.2	94

### Evacuation time(s/L) to reach different vacuum levels(-kPa)

Model	Air supply pressure bar	Air consumption NL/min	10	20	30	40	50	60	70	80	90	Max. vacuum level -kPa
AGX-S32-3	4.0	120	0.03	0.08	0.15	0.26	0.44	11.5	-	-	-	60
	5.0	125	0.03	0.07	0.13	0.23	0.38	27.3	1.07	-	-	70
	6.0	130	0.03	0.05	0.10	0.18	0.36	30.3	0.87	-	-	75
AGX-X40-3	4.5	120	0.03	0.07	0.13	0.23	0.38	24.5	0.97	1.50	3.25	91
	5.0	125	0.03	0.07	0.14	0.21	0.37	26.0	0.99	1.46	3.23	95
	6.0	135	0.03	0.05	0.10	0.16	0.27	26.0	0.86	1.45	3.92	94

### Dimensions(mm)

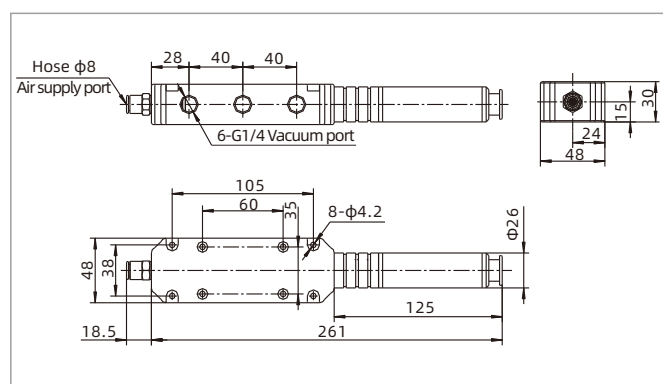

AGX

### AGX Air circuit schematic diagram

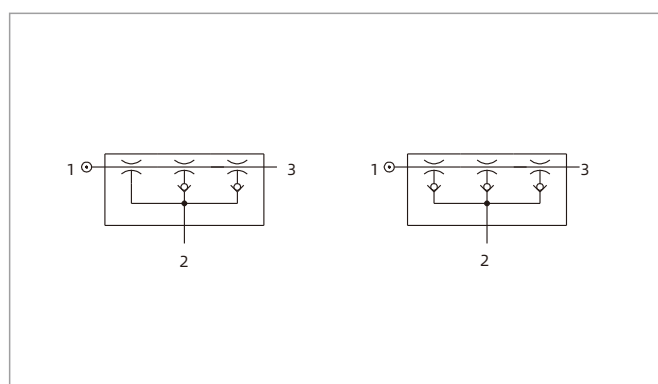

◇ Note: 1. Air supply port, 2. Vacuum port, 3. Exhaust port

# AGE Series

## Mechanical Energy-saving Vacuum Generator

**AIRBEST**



GLASS



METAL SHEET

RoHS

### Features

- ◇ Mechanical energy saving mode, the generator itself automatically saves energy after the vacuum level reaches the set value, and then the air supply stops
- ◇ Optional energy saving function can save up to 99% of the air consumption
- ◇ Can adapt to a variety of working conditions, can work in dust and water environment
- ◇ Internal blow valve allows rapid release of workpiece and maintain vacuum in sealed applications in the event of system or power failure
- ◇ Internal filter is equipped to protect the device from dust and particles

### Advantages

- ◇ Energy-saving function is realized by the generator itself, electric control is not required
- ◇ Strong anti-pollution ability
- ◇ Energy-saving function, it can help customers to minimize the cost
- ◇ Two-stage generator, vacuum level can reach to -92kPa quickly

### Applications

- ◇ Applicable to glass, metal sheet and other workpieces with good sealed surface
- ◇ Applicable to the occasions with water, dust and other places where the electric precision instrument can not work properly
- ◇ Suitable for glass grinding

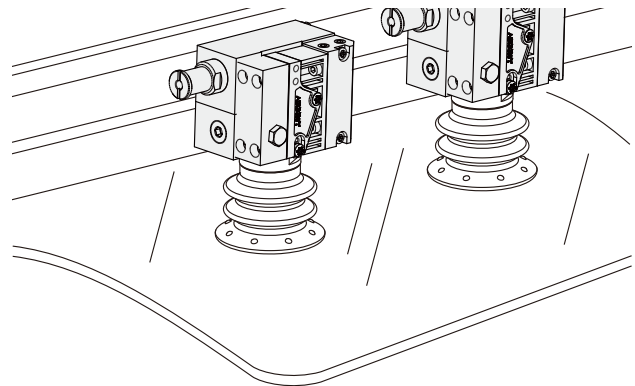

### Structure

- ◇ (1) Exhaust port
- ◇ (2) Mounting hole
- ◇ (3) Air supply port
- ◇ (4) Vacuum release port
- ◇ (5) Vacuum port
- ◇ (6) Vacuum detecting port
- ◇ (7) Energy-saving system adjustment rod

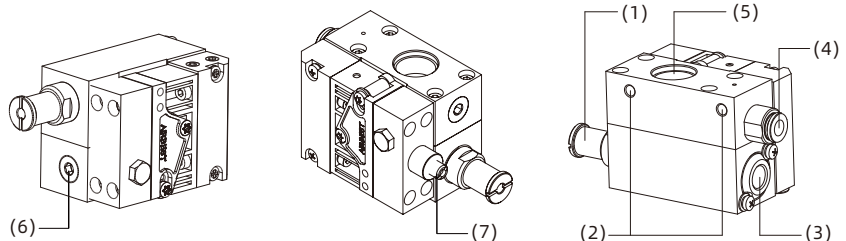

Note: The energy saving adjustable rod is only available in AGE-AS

Vacuum Generator

AZK

AZQ

AZX

AZD

AGS

AGP

AGX

**AGE**

ABM/ABX

ABM/ABX  
Combined Type

AMC

AM/AL/AH

AM/AL  
Combined Type

AMD

AZW

AZR

ABT

ABP

ABQ

AEVC

AZL

ALH

AZH

AZU

ACV

ASBP

ALS

ACP

ACPF

ACPS

APB

### How to order

## AGE - ES

①      ②

① Series	② Control device
AGE	Nil - Default, without control device ES - Energy-saving system AS - Energy-saving system adjustment rod

◇ Note: In AGE-ES, the adjustable range is from -50kPa to -70kPa

### Selection

Model/Control device	ES	AS
Nil		
AGE	AGE-ES	AGE-AS

### Technical parameters

Model	Rated air supply pressure bar	Max.vacuum level -kPa	Max.vacuum flow NL/min	Noise level dB(A)	Weight g
AGE	5.0	92	41	68.5	177
AGE-ES	5.0	92	41	68.5	258
AGE-AS	5.0	92	41	68.5	263

### Vacuum flow(NL/min) at different vacuum levels(-kPa)

Model	Air supply pressure bar	Air consumption NL/min	0	10	20	30	40	50	60	70	80	90	Max. vacuum level -kPa
AGE	5.0	29	42.1	31.3	23.8	15.8	10.4	8.4	6.0	3.6	1.3	0	92

### Evacuation time(s/L) to reach different vacuum levels(-kPa)

Model	Air supply pressure bar	Air consumption NL/min	10	20	30	40	50	60	70	80	90	Max. vacuum level -kPa
AGE	5.0	29	0.14	0.28	0.47	0.79	1.64	2.59	4.09	6.68	22.32	92

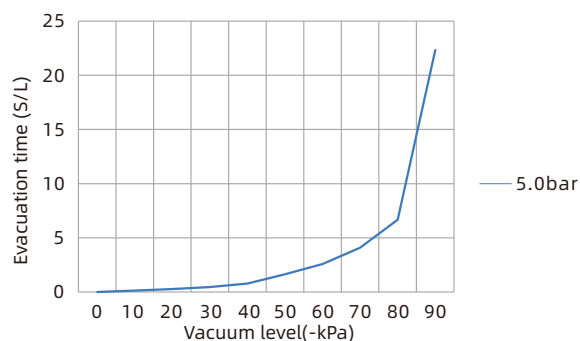
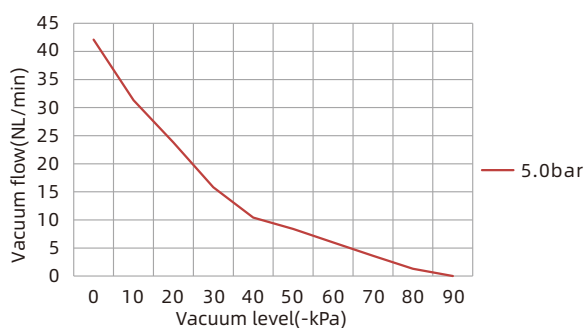

# AGE Series

## Mechanical Energy-saving Vacuum Generator



### Dimensions(mm)

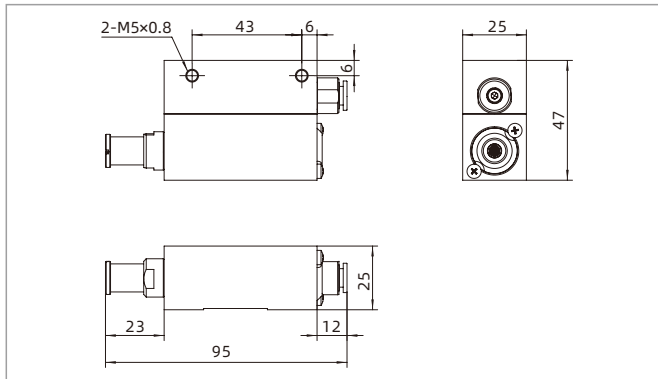

AGE

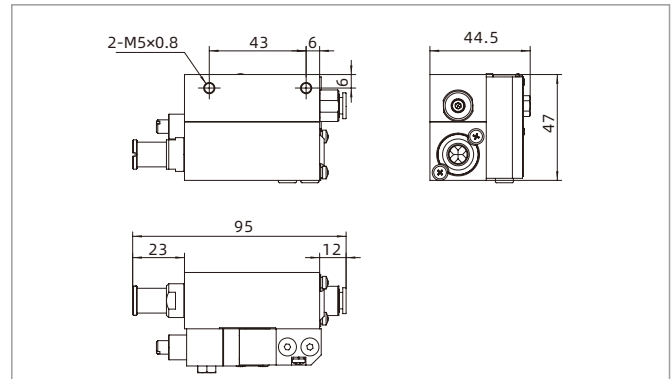

AGE-ES

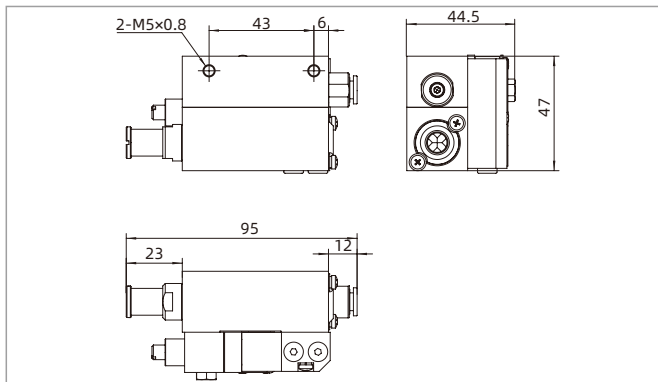

AGE-AS

### Air circuit schematic diagram

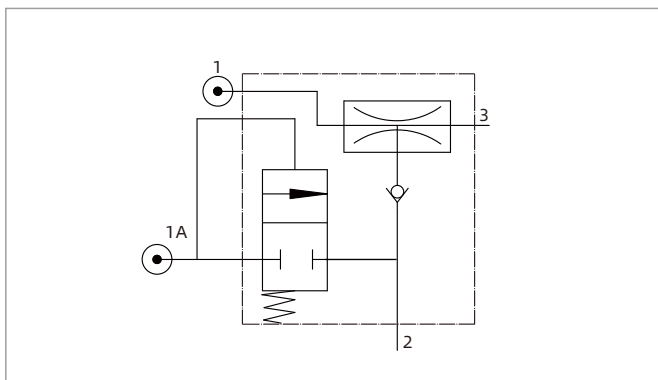

AGE

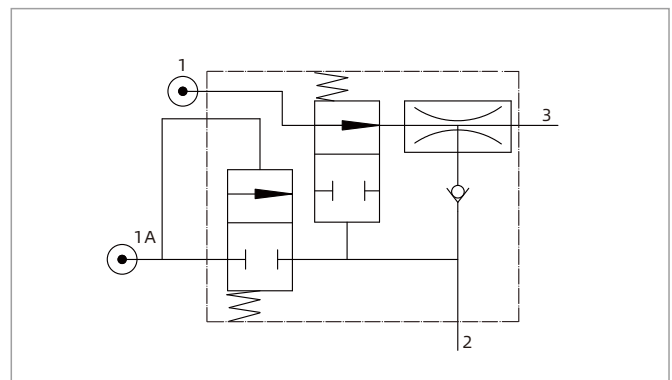

AGE-ES

Vacuum Generator

AZK

AZQ

AZX

AZD

AGS

AGP

AGX

**AGE**

ABM/ABX

ABM/ABX  
Combined Type

AMC

AM/AL/AH

AM/AL  
Combined Type

AMD

AZW

AZR

ABT

ABP

ABQ

AEVC

AZL

ALH

AZH

AZU

ACV

ASBP

ALS

ACP

ACPF

ACPS

APB

# ABM/ABX Series

## Mini Vacuum Generator



METAL SHEET



PACKAGING



PLASTIC

### Features

- ◇ Energy-efficient nozzle design
- ◇ Small size, light weight, can be connected with suction cup directly
- ◇ There are a variety of air port specifications (A,NA ,B,NB,C,NC)
- ◇ Built-in silencer and external silencer are optional

### Advantages

- ◇ It can produce more vacuum flow in the condition of less air consumption
- ◇ For the occasions with limited installation space and weight
- ◇ Suitable port connection specifications can be selected according to the on-site requirements
- ◇ It can meet different requirements of vacuum flow in different working conditions
- ◇ Reduce product noise greatly



### Applications

- ◇ Universal vacuum generator, widely used in all kinds of vacuum systems
- ◇ Suitable for metal plate handling, packaging machinery, injection molding and industrial robot technology field

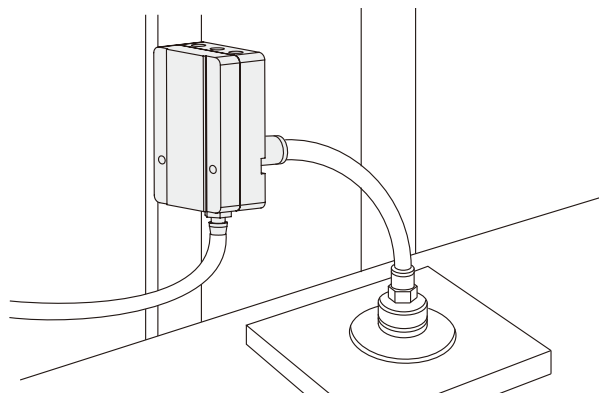

### Structure

- ◇ (1) Air supply port
- ◇ (2) Vacuum port
- ◇ (3) Exhaust port
- ◇ (4) Vacuum filter
- ◇ (5) Silencer

A NA type

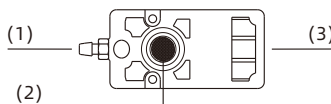

C NC type

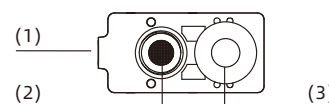

B NB type

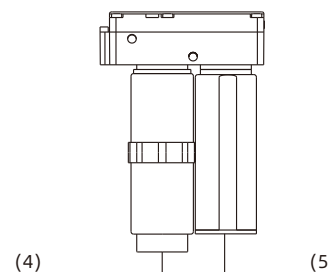
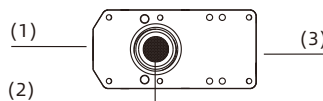

# ABM/ABX Series

## Mini Vacuum Generator

### How to order

**ABM 10 - B - F**  
 ①      ②      ③      ④

① Series	② Specification	③ Port connection	④ Sealing
ABM - Universal type (-85kPa)	5	A NA	Nil - Default,NBR
ABX - High vacuum level type (-92kPa)	10	B NB	F - Fluorine rubber
	20	C NC	E - EPDM
	30	(Refer to table1)	

### Port connection table1

Port connection	Air supply port	Vacuum port	Exhaust port	Applicable vacuum generator	
<b>A</b>	M5-φ6	G1/8	Internal silencer	ABM5、10	ABX5、10
<b>NA</b>	M5-φ6	NPSF1/8	Internal silencer	ABM5、10	ABX5、10
<b>B</b>	G1/8	G3/8	Internal silencer	ABM5、10、20、30	ABX5、10、20、30
<b>NB</b>	NPSF1/8	NPSF3/8	Internal silencer	ABM5、10、20、30	ABX5、10、20、30
<b>C</b>	G1/8	G3/8	External silencer	ABM5、10、20、30	ABX5、10、20、30
<b>NC</b>	NPSF1/8	NPSF3/8	External silencer	ABM5、10、20、30	ABX5、10、20、30

### Selection - ABM

Model/ Specification	A	NA	B	NB	C	NC
<b>ABM5-□</b>	ABM5-A	ABM5-NA	ABM5-B	ABM5-NB	ABM5-C	ABM5-NC
<b>ABM10-□</b>	ABM10-A	ABM10-NA	ABM10-B	ABM10-NB	ABM10-C	ABM10-NC
<b>ABM20-□</b>	-	-	ABM20-B	ABM20-NB	ABM20-C	ABM20-NC
<b>ABM30-□</b>	-	-	ABM30-B	ABM30-NB	ABM30-C	ABM30-NC

### Selection - ABX

Model/ Specification	A	NA	B	NB	C	NC
<b>ABX5-□</b>	ABX5-A	ABX5-NA	ABX5-B	ABX5-NB	ABX5-C	ABX5-NC
<b>ABX10-□</b>	ABX10-A	ABX10-NA	ABX10-B	ABX10-NB	ABX10-C	ABX10-NC
<b>ABX20-□</b>	-	-	ABX20-B	ABX20-NB	ABX20-C	ABX20-NC
<b>ABX30-□</b>	-	-	ABX30-B	ABX30-NB	ABX30-C	ABX30-NC

# ABM/ABX Series

## Mini Vacuum Generator



### Technical parameters - ABM

Model	Air supply pressure range bar	Max. vacuum level -kPa	Max. vacuum flow NL/min	Air consumption NL/min	Noise level dB(A)	Working temperature °C	Recommended hose dia. mm	
							Air supply port P	Vacuum port V
ABM5	4.5~6.0	85	35~37	12~20	50~65	-20~80	φ6	φ8
ABM10	4.5~6.0	85	70~75	28~42	55~68	-20~80	φ6	φ10
ABM20	4.5~6.0	85	141~150	55~85	60~68	-20~80	φ8	φ12
ABM30	4.5~6.0	85	175~220	87~125	60~68	-20~80	φ10	φ12

### Technical parameters - ABX

Model	Air supply pressure range bar	Max. vacuum level -kPa	Max. vacuum flow NL/min	Air consumption NL/min	Noise level dB(A)	Working temperature °C	Recommended hose dia. mm	
							Air supply port P	Vacuum port V
ABX5	4.5~6.0	92	30~32	18~22	50~65	-20~80	φ6	φ8
ABX10	4.5~6.0	92	52~63	31~40	55~68	-20~80	φ6	φ10
ABX20	4.5~6.0	92	110~125	79~89	60~69	-20~80	φ8	φ12
ABX30	4.5~6.0	92	180~185	128~137	60~69	-20~80	φ10	φ12

◇ Note: Max. air supply pressure is 7.0 bar

### Vacuum flow(NL/min) at different vacuum levels(-kPa)

Model	Air supply pressure bar	Air consumption NL/min	0	10	20	30	40	50	60	70	80	Max. vacuum level -kPa
ABM5	4.5	12	35.0	20.5	12.0	10.5	8.5	6.5	4.5	2.5	0.8	85
ABM10	4.5	28	70.0	40.5	25.0	21.0	18.0	14.0	9.5	5.0	1.3	85
ABM20	4.5	55	141.0	77.0	45.0	39.5	29.5	25.0	17.5	12.0	3.0	85
ABM30	4.5	87	175.0	105.0	70.0	63.0	53.0	40.0	26.0	14.0	6.5	85
ABM5	6.0	20	37.0	25.0	15.5	12.0	8.0	6.0	4.0	2.7	0.6	85
ABM10	6.0	42	75.0	55.0	27.0	20.0	18.0	12.0	9.0	5.0	2.0	85
ABM20	6.0	85	150.0	100.0	55.0	38.0	30.0	24.0	16.0	11.0	3.2	85
ABM30	6.0	125	220.0	150.0	81.0	65.0	50.0	38.0	27.0	18.0	5.0	85

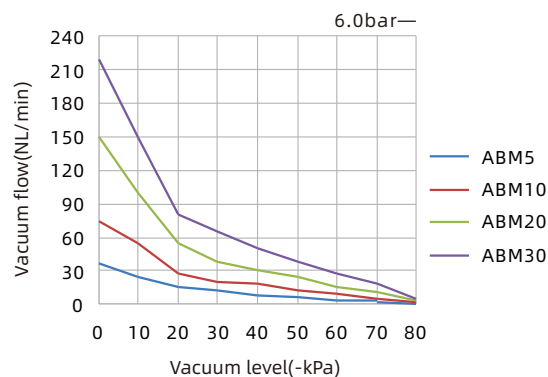
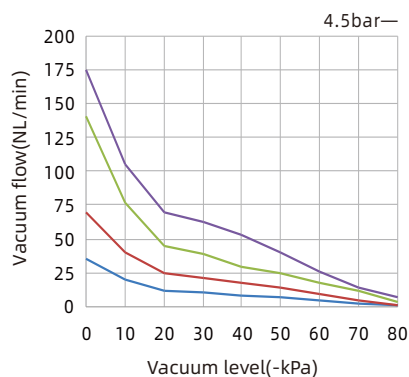

# ABM/ABX Series

## Mini Vacuum Generator



### Evacuation time(S/L) to reach different vacuum levels(-kPa)

Model	Air supply pressure bar	Air consumption NL/min	10	20	30	40	50	60	70	80	Max. vacuum level -kPa
ABM5	4.5	12	0.11	0.42	0.95	1.66	2.50	3.65	5.25	7.89	85
ABM10	4.5	28	0.08	0.20	0.44	0.80	1.24	1.80	2.55	3.80	85
ABM20	4.5	55	0.04	0.12	0.23	0.41	0.65	0.93	1.33	2.03	85
ABM30	4.5	87	0.03	0.09	0.16	0.27	0.43	0.66	0.95	1.43	85
ABM5	6.0	20	0.13	0.51	1.15	1.93	2.87	4.09	5.84	10.46	85
ABM10	6.0	42	0.03	0.23	0.53	0.92	1.37	1.95	2.77	4.62	85
ABM20	6.0	85	0.02	0.15	0.28	0.46	0.71	1.02	1.48	2.55	85
ABM30	6.0	125	0.02	0.08	0.14	0.31	0.49	0.69	1.02	1.75	85

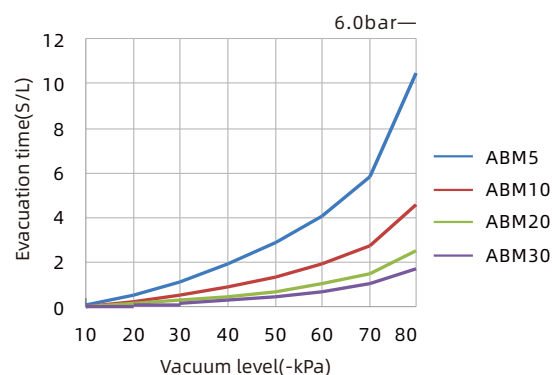
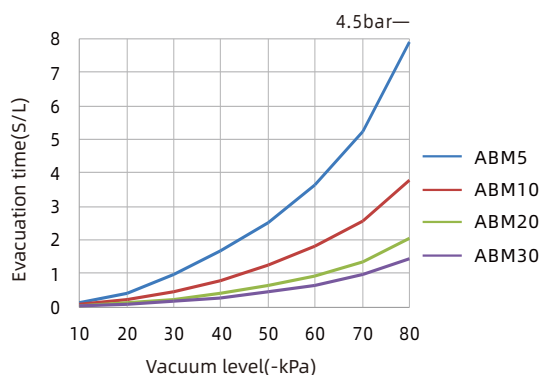

### Vacuum flow(NL/min) at different vacuum levels(-kPa)

Model	Air supply pressure bar	Air consumption NL/min	0	10	20	30	40	50	60	70	80	90	Max. vacuum level -kPa
ABX5	4.5	18	30.0	13.0	7.5	7.0	6.0	5.0	4.0	3.2	1.8	0.4	92
ABX10	4.5	31	52.0	24.0	18.0	15.0	13.0	10.5	8.0	6.0	2.5	0.8	92
ABX20	4.5	79	100.0	46.0	34.0	30.5	25.0	21.0	17.0	10.5	5.0	1.6	92
ABX30	5.0	128	180.0	95.0	55.0	45.5	40.5	30.5	25.0	19.0	11.5	3.0	92
ABX5	6.0	22	32.0	20.0	8.5	7.5	6.0	5.0	4.0	3.0	1.5	0.15	92
ABX10	6.0	40	63.0	36.0	18.0	16.0	12.5	10.5	8.5	6.0	3.5	0.5	92
ABX20	6.0	89	125.0	73.0	35.0	30.0	25.0	22.0	18.0	12.0	7.0	0.9	92
ABX30	6.0	137	185.0	103.0	51.0	46.0	38.0	31.0	25.0	19.0	12.0	1.8	92

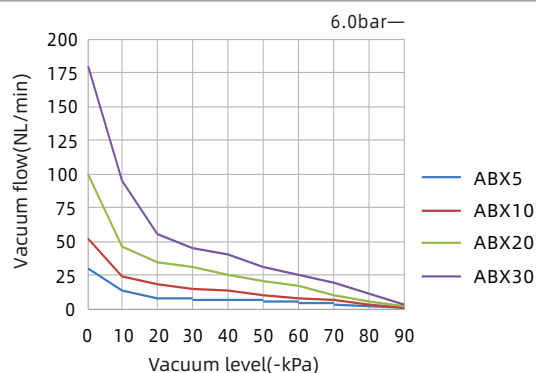
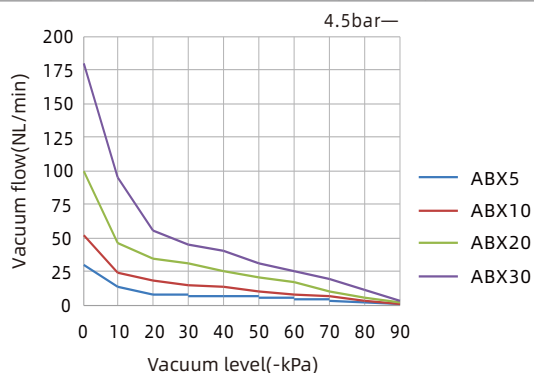

Vacuum Generator

AZK

AZQ

AZX

AZD

AGS

AGP

AGX

AGE

ABM/ABX

ABM/ABX Combined Type

AMC

AM/AL/AH

AM/AL Combined Type

AMD

AZW

AZR

ABT

ABP

ABQ

AEVC

AZL

ALH

AZH

AZU

ACV

ASBP

ALS

ACP

ACPF

ACPS

APB

# ABM/ABX Series

## Mini Vacuum Generator



### Evacuation time(s/L) to reach different vacuum levels(-kPa)

Model	Air supply pressure bar	Air consumption NL/min	10	20	30	40	50	60	70	80	90	Max. vacuum level -kPa
ABX5	4.5	18	0.13	0.60	1.26	2.30	3.20	4.50	6.15	8.50	15.50	92
ABX10	4.5	31	0.11	0.30	0.65	1.10	1.55	2.15	2.85	4.70	10.20	92
ABX20	4.5	79	0.09	0.16	0.32	0.55	0.80	1.50	1.80	2.70	5.00	92
ABX30	5.0	128	0.06	0.12	0.23	0.36	0.53	0.76	1.10	1.60	2.90	92
ABX5	6.0	22	0.15	0.71	1.52	2.54	3.72	5.12	6.95	9.70	21.00	92
ABX10	6.0	40	0.09	0.32	0.71	1.18	1.74	2.40	3.26	4.55	10.20	92
ABX20	6.0	89	0.05	0.15	0.31	0.52	0.77	1.08	1.54	2.15	4.92	92
ABX30	6.0	137	0.03	0.13	0.23	0.38	0.58	0.82	1.11	1.54	3.00	92

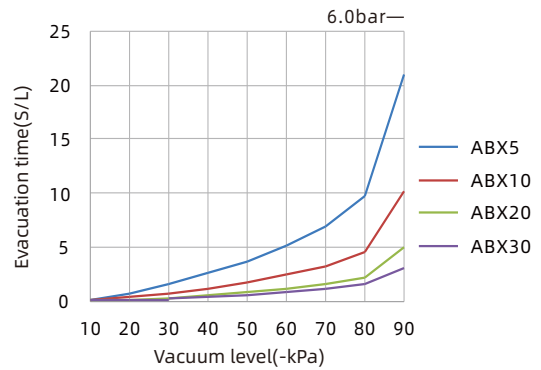
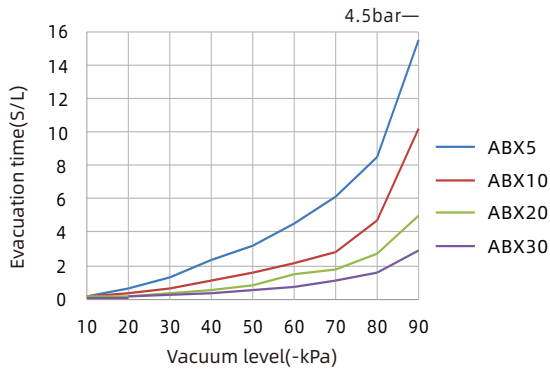

### Dimensions(mm)

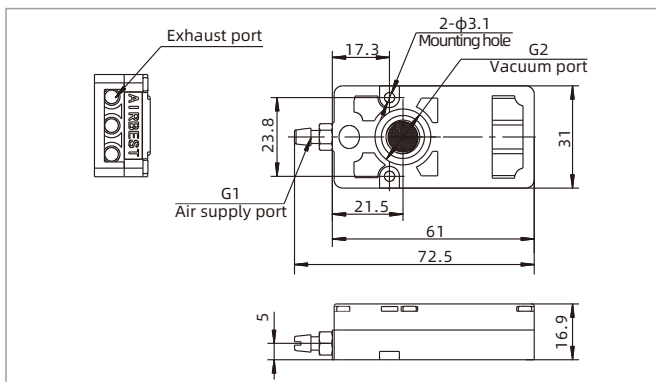

ABM5-A/NA ABM10-A/NA  
 ABX5-A/NA ABX10-A/NA

Model/size	G1	G2	Weight g
ABM/ABX5-A	φ6	G1/8	58
ABM/ABX5-NA	φ6	NPSF1/8	58
ABM/ABX10-A	φ6	G1/8	59
ABM/ABX10-NA	φ6	NPSF1/8	59

# ABM/ABX Series

## Mini Vacuum Generator



### Dimensions(mm)

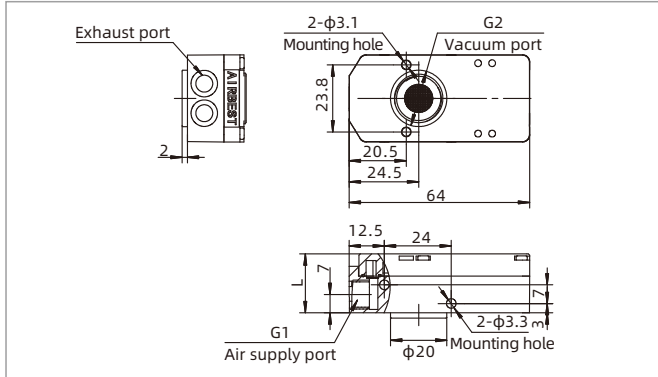

ABM(5-30)-B/NB      ABX(5-30)-B/NB

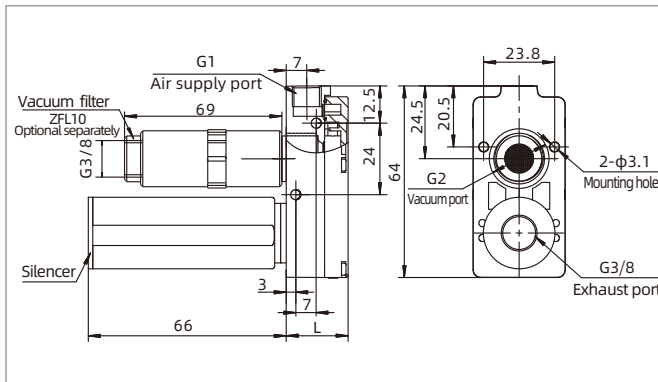

ABM(5-30)-C/NC      ABX(5-30)-C/NC

Model/size	G1	G2	L	Weight g
ABM/ABX5-B	G1/8	G3/8	20.7	64
ABM/ABX5-NB	NPSF1/8	NPSF3/8	20.7	64
ABM/ABX10-B	G1/8	G3/8	20.7	64
ABM/ABX10-NB	NPSF1/8	NPSF3/8	20.7	64
ABM/ABX20-B	G1/8	G3/8	28	77
ABM/ABX20-NB	NPSF1/8	NPSF3/8	28	77
ABM/ABX30-B	G1/8	G3/8	35	89
ABM/ABX30-NB	NPSF1/8	NPSF3/8	35	89

Model/size	G1	G2	L	Weight g
ABM/ABX5-C	G1/8	G3/8	20.7	84
ABM/ABX5-NC	NPSF1/8	NPSF3/8	20.7	84
ABM/ABX10-C	G1/8	G3/8	20.7	87
ABM/ABX10-NC	NPSF1/8	NPSF3/8	20.7	87
ABM/ABX20-C	G1/8	G3/8	28	100
ABM/ABX20-NC	NPSF1/8	NPSF3/8	28	100
ABM/ABX30-C	G1/8	G3/8	35	112
ABM/ABX30-NC	NPSF1/8	NPSF3/8	35	112

### Repair kits

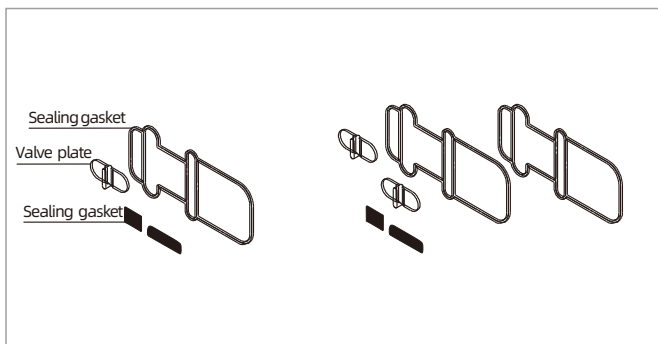

ABM10-PK

ABM20-PK

ABM30-PK

Item	Sealing kits model			Model	Applicable vacuum generator
	NBR	F	E		
Sealing kits	ABM10-PK	ABM10-F-PK	ABM10-E-PK	-	ABM/ABX(5-10)
Sealing kits	ABM20-PK	ABM20-F-PK	ABM20-E-PK	-	ABM/ABX20
Sealing kits	ABM30-PK	ABM30-F-PK	ABM30-E-PK	-	ABM/ABX30
Vacuum filter	-	-	-	ZFL10	ABM/ABX(5-30)-B,NB,C,NC
Silencer	-	-	-	ZSA-G3M	ABM/ABX(5-30)-C,NC

Vacuum Generator

AZK  
AZQ  
AZX  
AZD

AGS  
AGP  
AGX

AGE

ABM/ABX

ABM/ABX Combined Type

AMC

AM/AL/AH

AM/AL Combined Type

AMD

AZW

AZR

ABT

ABP

ABQ

AEVC

AZL

ALH

AZH

AZU

ACV

ASBP

ALS

ACP

ACPF

ACPS

APB

# ABM/ABX Series

## Mini Combined Type Vacuum Generator



METAL SHEET



PACKAGING



PLASTIC



### Features

- ◇ Energy-efficient nozzle design
- ◇ Small size, light weight, compact structure, easy installation
- ◇ Can be operated with a single pneumatic control valve, each vacuum circuit can be controlled by each ABM/ABX and does not affect the running of other circuits

### Advantages

- ◇ It can produce more vacuum flow in the condition of less air consumption
- ◇ For the occasions with limited installation space and weight
- ◇ It is convenient to control, it can control each circuit separately in the working condition of multiple units are used seperately
- ◇ It can meet different requirements of vacuum flow in different working conditions



### Applications

- ◇ Universal vacuum generator, widely used in all kinds of vacuum systems
- ◇ Suitable for metal plate handling, packaging machinery, injection molding and industrial robot technology field

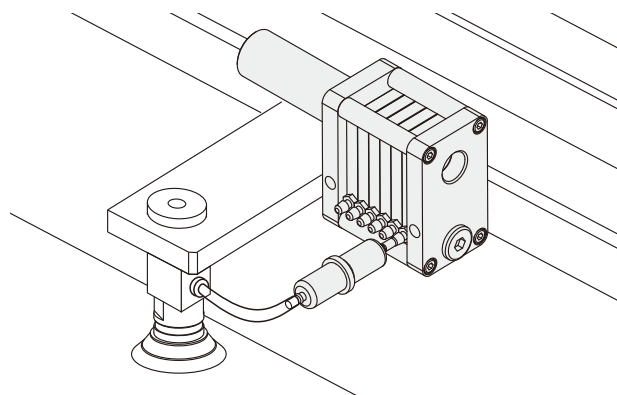

### Structure

- ◇ (1) Air supply port
- ◇ (2) Mounting hole
- ◇ (3) Silencer
- ◇ (4) Vacuum port
- ◇ (5) Vacuum filter

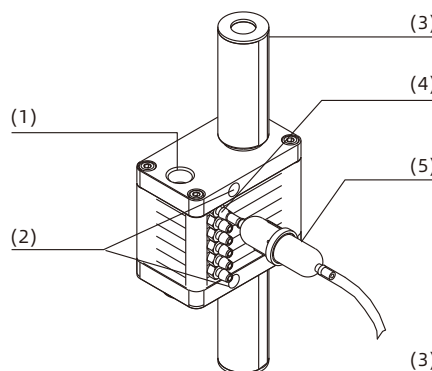

# ABM/ABX Series

## Mini Combined Type Vacuum Generator

### How to order

**ABM 5 × 5 - 4 - F**  
 ①      ②      ③      ④      ⑤

① Series	② Specification	③ Vacuum stack	④ Hose inner dia.at vacuum port	⑤ Sealing
ABM - Universal type(-85kPa)	5	2	4 - φ4mm	Nil - Default, NBR
ABX - High vacuum level type(-92kPa)	10	3		F - Fluorine rubber
		.....		E - EPDM
		16		

### Selection

Model/ Specification	5	10	Model/ Specification	5	10
ABM□×2-4	ABM5×2-4	ABM10×2-4	ABX□×2-4	ABX5×2-4	ABX10×2-4
ABM□×3-4	ABM5×3-4	ABM10×3-4	ABX□×3-4	ABX5×3-4	ABX10×3-4
ABM□×4-4	ABM5×4-4	ABM10×4-4	ABX□×4-4	ABX5×4-4	ABX10×4-4
ABM□×5-4	ABM5×5-4	ABM10×5-4	ABX□×5-4	ABX5×5-4	ABX10×5-4
ABM□×6-4	ABM5×6-4	ABM10×6-4	ABX□×6-4	ABX5×6-4	ABX10×6-4
ABM□×7-4	ABM5×7-4	ABM10×7-4	ABX□×7-4	ABX5×7-4	ABX10×7-4
ABM□×8-4	ABM5×8-4	ABM10×8-4	ABX□×8-4	ABX5×8-4	ABX10×8-4
ABM□×9-4	ABM5×9-4	ABM10×9-4	ABX□×9-4	ABX5×9-4	ABX5×9-4
ABM□×10-4	ABM5×10-4	ABM10×10-4	ABX□×10-4	ABX5×10-4	ABX5×10-4
ABM□×11-4	ABM5×11-4	ABM10×11-4	ABX□×11-4	ABX5×11-4	ABX5×11-4
ABM□×12-4	ABM5×12-4	ABM10×12-4	ABX□×12-4	ABX5×12-4	ABX5×12-4
ABM□×13-4	ABM5×13-4	ABM10×13-4	ABX□×13-4	ABX5×13-4	-
ABM□×14-4	ABM5×14-4	ABM10×14-4	ABX□×14-4	ABX5×14-4	-
ABM□×15-4	ABM5×15-4	ABM10×15-4	ABX□×15-4	ABX5×15-4	-
ABM□×16-4	ABM5×16-4	ABM10×16-4	ABX□×16-4	ABX5×16-4	-

Vacuum Generator

AZK

AZQ

AZX

AZD

AGS

AGP

AGX

AGE

ABM/ABX

ABM/ABX  
Combined Type

AMC

AM/AL/AH

AM/AL  
Combined Type

AMD

AZW

AZR

ABT

ABP

ABQ

AEVC

AZL

ALH

AZH

AZU

ACV

ASBP

ALS

ACP

ACPF

ACPS

APB

# ABM/ABX Series

## Mini Combined Type Vacuum Generator



### Technical parameters

Model	Air supply pressure range bar	Max. vacuum level -kPa	Max. vacuum flow NL/min	Air consumption NL/min	Noise level dB(A)	Working temperature °C	Weight g	Recommended hose dia. (mm)		
								Air supply port P	Vacuum port V	Exhaust port E
ABM5×2-4	4.5~6.0	85	25×2	29~41	50~60	-20~80	67	φ6	φ6	G3/8×1
ABM5×3-4	4.5~6.0	85	25×3	44~64	50~60	-20~80	80	φ6	φ6	G3/8×1
ABM5×4-4	4.5~6.0	85	25×4	61~85	50~60	-20~80	247	φ8	φ6	G3/8×1
ABM5×5-4	4.5~6.0	85	25×5	71~104	60~65	-20~80	255	φ8	φ6	G3/8×1
ABM5×6-4	4.5~6.0	85	25×6	89~125	60~65	-20~80	281	φ8	φ6	G3/8×1
ABM5×7-4	4.5~6.0	85	25×7	104~145	60~65	-20~80	299	φ8	φ6	G3/8×1
ABM5×8-4	4.5~6.0	85	25×8	120~168	60~65	-20~80	317	φ10	φ6	G3/8×1
ABM5×9-4	4.5~6.0	85	25×9	132~190	60~65	-20~80	335	φ10	φ6	G3/8×1
ABM5×10-4	4.5~6.0	85	25×10	148~211	60~65	-20~80	353	φ10	φ6	G3/8×1
ABM5×11-4	4.5~6.0	85	25×11	165~232	60~65	-20~80	371	φ10	φ6	G3/8×1
ABM5×12-4	4.5~6.0	85	25×12	180~252	60~65	-20~80	389	φ10	φ6	G3/8×2
ABM5×13-4	4.5~6.0	85	25×13	195~275	60~65	-20~80	417	φ10	φ6	G3/8×2
ABM5×14-4	4.5~6.0	85	25×14	208~293	60~65	-20~80	435	φ10	φ6	G3/8×2
ABM5×15-4	4.5~6.0	85	25×15	225~316	60~65	-20~80	453	φ12	φ6	G3/8×2
ABM5×16-4	4.5~6.0	85	25×16	241~335	60~65	-20~80	471	φ12	φ6	G3/8×2
ABM10×2-4	4.5~6.0	85	32×2	61~85	55~60	-20~80	67	φ8	φ6	G3/8×1
ABM10×3-4	4.5~6.0	85	32×3	91~125	60~65	-20~80	80	φ8	φ6	G3/8×1
ABM10×4-4	4.5~6.0	85	32×4	121~167	60~65	-20~80	247	φ10	φ6	G3/8×1
ABM10×5-4	4.5~6.0	85	32×5	151~212	60~65	-20~80	255	φ10	φ6	G3/8×1
ABM10×6-4	4.5~6.0	85	32×6	185~255	60~65	-20~80	281	φ10	φ6	G3/8×2
ABM10×7-4	4.5~6.0	85	32×7	211~295	60~65	-20~80	299	φ10	φ6	G3/8×2
ABM10×8-4	4.5~6.0	85	32×8	241~335	60~65	-20~80	327	φ10	φ6	G3/8×2
ABM10×9-4	4.5~6.0	85	32×9	271~376	60~65	-20~80	345	φ12	φ6	G3/8×2
ABM10×10-4	4.5~6.0	85	32×10	301~421	60~65	-20~80	363	φ12	φ6	G3/8×2
ABM10×11-4	4.5~6.0	85	32×11	332~463	60~65	-20~80	381	φ12	φ6	G3/8×2
ABM10×12-4	4.5~6.0	85	32×12	361~505	60~65	-20~80	399	φ12	φ6	G3/8×2

◇ Note: Max. air supply pressure is 7.0 bar

### Vacuum flow(NL/min) at different vacuum levels(-kPa)

Model	Air supply pressure bar	Air consumption NL/min	Vacuum level (-kPa)										Max. vacuum level -kPa
			0	10	20	30	40	50	60	70	80	90	
ABM5×1	6.0	20	25.0	15.0	12.5	11.0	10.0	7.5	5.5	2.0	0.6	-	85
ABM10×1	6.0	42	32.0	28.0	24.0	22.0	18.0	15.0	11.0	5.0	1.4	-	85

### Evacuation time(s/L) to reach different vacuum levels(-kPa)

Model	Air supply pressure bar	Air consumption NL/min	Vacuum level (-kPa)										Max. vacuum level -kPa
			10	20	30	40	50	60	70	80	90		
ABM5×1	6.0	20	0.20	0.59	1.10	1.58	2.40	3.52	5.30	10.30	-	85	
ABM10×1	6.0	42	0.12	0.28	0.60	0.81	1.18	1.82	2.65	5.21	-	85	

# ABM/ABX Series

## Mini Combined Type Vacuum Generator



### Technical parameters

Model	Air supply pressure range bar	Max. vacuum level -kPa	Max. vacuum flow NL/min	Air consumption NL/min	Noise level dB(A)	Working temperature °C	Weight g	Recommended hose dia. mm		
								Air supply port P	Vacuum port V	Exhaust port E
ABX5×2-4	4.5~6.0	92	23×2	43~49	55~60	-20~80	67	φ6	φ6	G3/8×1
ABX5×3-4	4.5~6.0	92	23×3	65~73	55~60	-20~80	80	φ6	φ6	G3/8×1
ABX5×4-4	4.5~6.0	92	23×4	85~96	60~63	-20~80	247	φ8	φ6	G3/8×1
ABX5×5-4	4.5~6.0	92	23×5	106~121	60~63	-20~80	255	φ8	φ6	G3/8×1
ABX5×6-4	4.5~6.0	92	23×6	130~144	60~63	-20~80	281	φ8	φ6	G3/8×1
ABX5×7-4	4.5~6.0	92	23×7	151~167	60~63	-20~80	299	φ8	φ6	G3/8×1
ABX5×8-4	4.5~6.0	92	23×8	173~193	60~63	-20~80	317	φ10	φ6	G3/8×1
ABX5×9-4	4.5~6.0	92	23×9	195~217	60~63	-20~80	335	φ10	φ6	G3/8×1
ABX5×10-4	4.5~6.0	92	23×10	215~241	60~63	-20~80	353	φ10	φ6	G3/8×1
ABX5×11-4	4.5~6.0	92	23×11	238~265	60~63	-20~80	371	φ10	φ6	G3/8×1
ABX5×12-4	4.5~6.0	92	23×12	260~289	60~63	-20~80	389	φ10	φ6	G3/8×2
ABX5×13-4	4.5~6.0	92	23×13	281~313	60~63	-20~80	417	φ10	φ6	G3/8×2
ABX5×14-4	4.5~6.0	92	23×14	335~346	60~63	-20~80	435	φ10	φ6	G3/8×2
ABX5×15-4	4.5~6.0	92	23×15	361~389	63~65	-20~80	453	φ10	φ6	G3/8×2
ABX5×16-4	4.5~6.0	92	23×16	346~385	63~65	-20~80	471	φ10	φ6	G3/8×2
ABX10×2-4	4.5~6.0	92	32×2	87~96	63~65	-20~80	67	φ8	φ6	G3/8×1
ABX10×3-4	4.5~6.0	92	32×3	130~145	63~65	-20~80	80	φ8	φ6	G3/8×1
ABX10×4-4	4.5~6.0	92	32×4	173~193	63~65	-20~80	247	φ10	φ6	G3/8×1
ABX10×5-4	4.5~6.0	92	32×5	215~241	63~65	-20~80	255	φ10	φ6	G3/8×1
ABX10×6-4	4.5~6.0	92	32×6	260~288	63~65	-20~80	281	φ10	φ6	G3/8×2
ABX10×7-4	4.5~6.0	92	32×7	303~337	63~65	-20~80	299	φ10	φ6	G3/8×2
ABX10×8-4	4.5~6.0	92	32×8	346~385	63~65	-20~80	327	φ10	φ6	G3/8×2
ABX10×9-4	4.5~6.0	92	32×9	389~433	63~65	-20~80	345	φ12	φ6	G3/8×2
ABX10×10-4	4.5~6.0	92	32×10	433~481	63~65	-20~80	363	φ12	φ6	G3/8×2
ABX10×11-4	4.5~6.0	92	32×11	476~529	63~65	-20~80	381	φ12	φ6	G3/8×2
ABX10×12-4	4.5~6.0	92	32×12	519~578	63~65	-20~80	399	φ12	φ6	G3/8×2

◇ Note: Max. air supply pressure is 7.0 bar.

### Vacuum flow(NL/min) at different vacuum levels(-kPa)

Model	Air supply pressure bar	Air consumption NL/min	Vacuum level -kPa											Max. vacuum level -kPa
			0	10	20	30	40	50	60	70	80	90		
ABX5×1	6.0	22	23.0	14.0	10.0	9.0	7.5	6.0	4.0	2.8	1.5	0.44	92	
ABX10×1	6.0	40	32.0	21.0	18.0	16.0	14.0	11.0	9.5	5.5	2.5	1.10	92	

### Evacuation time(s/L) to reach different vacuum levels(-kPa)

Model	Air supply pressure bar	Air consumption NL/min	Vacuum level -kPa											Max. vacuum level -kPa
			10	20	30	40	50	60	70	80	90			
ABX5×1	6.0	22	0.21	0.81	1.52	2.35	3.48	4.85	6.57	10.50	19.30	92		
ABX10×1	6.0	40	0.14	0.40	0.78	1.22	1.77	2.40	3.30	4.95	9.62	92		

Vacuum Generator

AZK

AZQ

AZX

AZD

AGS

AGP

AGX

AGE

ABM/ABX

ABM/ABX Combined Type

AMC

AM/AL/AH

AM/AL Combined Type

AMD

AZW

AZR

ABT

ABP

ABQ

AEVC

AZL

ALH

AZH

AZU

ACV

ASBP

ALS

ACP

ACPF

ACPS

APB

# ABM/ABX Series

## Mini Combined Type Vacuum Generator



### Dimensions(mm)

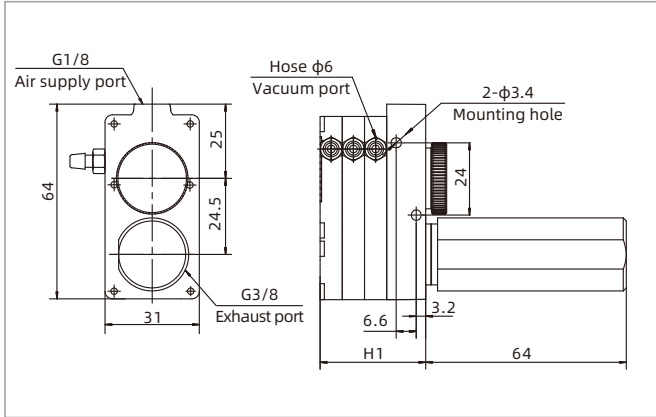

ABM/ABX□×2-4    ABM/ABX□×3-4

Model/size	H1	H2	L
ABM/ABX5×2-4	28	-	-
ABM/ABX5×3-4	36	-	-
ABM/ABX5×4-4	50.4	40.5	-
ABM/ABX5×5-4	58	48	-
ABM/ABX5×6-4	65.16	55.5	-
ABM/ABX5×7-4	73.2	63	-
ABM/ABX5×8-4	80.8	70	-
ABM/ABX5×9-4	88.4	77.5	-
ABM/ABX5×10-4	96	85	-
ABM/ABX5×11-4	103.6	92.5	-
ABM/ABX5×12-4	111.2	100	64
ABM/ABX5×13-4	118.8	107.5	64
ABM/ABX5×14-4	126.4	115	64
ABM/ABX5×15-4	134	122.5	64
ABM/ABX5×16-4	141.6	130	64

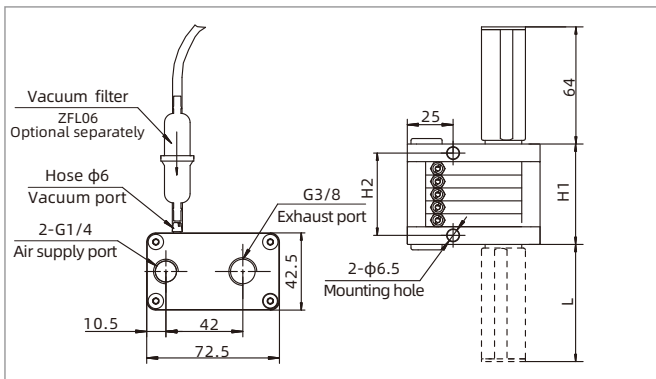

ABM/ABX□× (4-8)-4

Model/size	H1	H2	L
ABM/ABX10×2-4	28	-	-
ABM/ABX10×3-4	36	-	-
ABM/ABX10×4-4	50.4	40.4	-
ABM/ABX10×5-4	58	48	-
ABM/ABX10×6-4	65.6	55.6	-
ABM/ABX10×7-4	73.2	63.2	-
ABM/ABX10×8-4	80.8	70.8	-
ABM/ABX10×9-4	88.4	78.4	-
ABM/ABX10×10-4	96	86	-
ABM/ABX10×11-4	103.6	93.6	-
ABM/ABX10×12-4	111.2	101.2	64

### Repair kits

Item	Model
Vacuum filter	ZFL06
Silencer	ZSA-G3M

# AMC Series

## Multistage Vacuum Generator

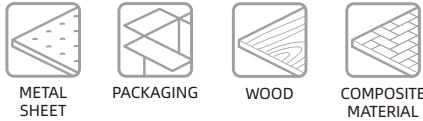

### Features

- ◇ High efficient and energy-saving multistage nozzle design
- ◇ Large vacuum flow
- ◇ Internal vacuum cartridges can be stacked assembly
- ◇ Various specifications of air supply port and vacuum port
- ◇ Energy-saving control device is optional

### Advantages

- ◇ Quick evacuation in low vacuum level range, reduce cost and shorten working cycle
- ◇ Producing large vacuum flow to handle porous workpieces fast and safely
- ◇ It can meet different requirements of vacuum flow in different working conditions
- ◇ It can be connected with different threads
- ◇ It is energy-saving when handling airtight workpieces



### Applications

- ◇ The multistage vacuum generator is suitable for handling cartons, packaging materials and porous materials
- ◇ It is used in the working condition requiring large vacuum flow, fast evacuation speed and less air consumption

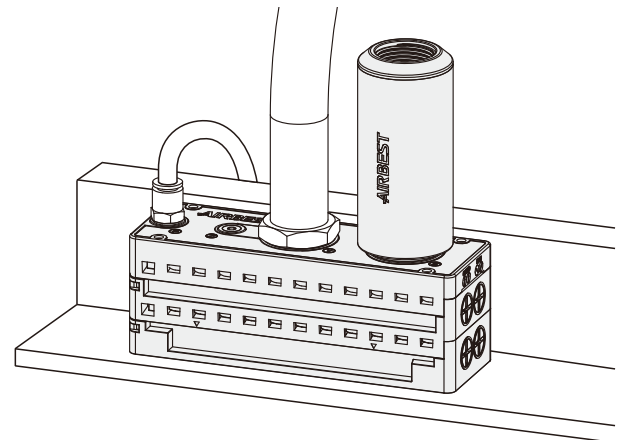

### Structure

- ◇ (1) Main body
- ◇ (2) Vacuum gauge
- ◇ (3) Silencer
- ◇ (4) Air supply port
- ◇ (5) Vacuum port
- ◇ (6) L-type mounting bracket
- ◇ (7) ES energy saving system

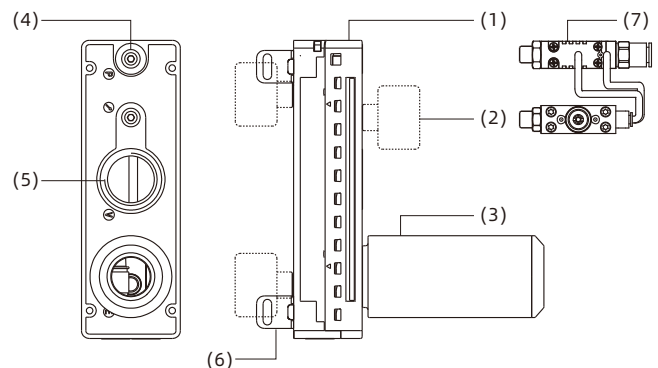

AZK

AZQ

AZX

AZD

AGS

AGP

AGX

AGE

ABM/ABX

ABM/ABX  
Combined Type

**AMC**

AM/AL/AH

AM/AL  
Combined Type

AMD

AZW

AZR

ABT

ABP

ABQ

AEVC

AZL

ALH

AZH

AZU

ACV

ASBP

ALS

ACP

ACPF

ACPS

APB

# AMC Series

## Multistage Vacuum Generator

### How to order

**AMC 25 L - AA - V - ES**  
 ①      ②      ③      ④      ⑤      ⑥

Series	Specification	Performance	④ Connection plate	⑤ Non-return valve	⑥ Control device
AMC	25	H - High vacuum level	AA	Nil - Default, without	Nil - Default, Without control device
	50	(-95kPa)	BA	non-return valve	ES - Energy saving system
	75	L - Large vacuum flow	CA	V - With non-return valve	
	100	(-75kPa)	DB		
	125		CC		
	150				

◇ Note: When -V non-return valve or -ES energy-saving system is selected, the vacuum filter is needed.

### Connection plate specifications

Connection plate	Air supply port <sup>(1)</sup>	Vacuum port <sup>(2)</sup>	Exhaust port <sup>(3)</sup>	Applicable vacuum generator
AA	G1/8	G3/4	G1"	AMC25, 50
BA	NPSF1/8	G3/4	G1"	AMC25, 50
CA	G1/4	G3/4	G1"	AMC25, 50, 75, 100
DB	NPT1/4	NPT3/4	G1"	AMC25, 50, 75, 100
CC	G1/4	G1"	G1"	AMC25, 50, 75, 100, 125, 150

### Selection - L (Large Vacuum flow type)

Model/ Specification	25	50	75	100	125	150
AMC□L-AA	AMC25L-AA	AMC50L-AA	-	-	-	-
AMC□L-AA-V	AMC25L-AA-V	AMC50L-AA-V	-	-	-	-
AMC□L-AA-V-ES	AMC25L-AA-V-ES	AMC50L-AA-V-ES	-	-	-	-
AMC□L-BA	AMC25L-BA	AMC50L-BA	-	-	-	-
AMC□L-BA-V	AMC25L-BA-V	AMC50L-BA-V	-	-	-	-
AMC□L-CA	AMC25L-CA	AMC50L-CA	AMC75L-CA	AMC100L-CA	-	-
AMC□L-CA-V	AMC25L-CA-V	AMC50L-CA-V	AMC75L-CA-V	AMC100L-CA-V	-	-
AMC□L-CA-V-ES	-	-	AMC75L-CA-V-ES	AMC100L-CA-V-ES	-	-
AMC□L-DB	AMC25L-DB	AMC50L-DB	AMC75L-DB	AMC100L-DB	-	-
AMC□L-DB-V	AMC25L-DB-V	AMC50L-DB-V	AMC75L-DB-V	AMC100L-DB-V	-	-
AMC□L-CC	AMC25L-CC	AMC50L-CC	AMC75L-CC	AMC100L-CC	AMC125L-CC	AMC150L-CC
AMC□L-CC-V	AMC25L-CC-V	AMC50L-CC-V	AMC75L-CC-V	AMC100L-CC-V	AMC125L-CC-V	AMC150L-CC-V
AMC□L-CC-V-ES	AMC25L-CC-V-ES	AMC50L-CC-V-ES	AMC75L-CC-V-ES	AMC100L-CC-V-ES	AMC125L-CC-V-ES	AMC150L-CC-V-ES

# AMC Series

## Multistage Vacuum Generator



### Selection - H (High vacuum level type)

Model/ Specification	25	50	75	100	125	150
AMC□H-AA	AMC25H-AA	AMC50H-AA	-	-	-	-
AMC□H-AA-V	AMC25H-AA-V	AMC50H-AA-V	-	-	-	-
AMC□H-AA-V-ES	AMC25H-AA-V-ES	AMC50H-AA-V-ES	-	-	-	-
AMC□H-BA	AMC25H-BA	AMC50H-BA	-	-	-	-
AMC□H-BA-V	AMC25H-BA-V	AMC50H-BA-V	-	-	-	-
AMC□H-CA	AMC25H-CA	AMC50H-CA	AMC75H-CA	AMC100H-CA	-	-
AMC□H-CA-V	AMC25H-CA-V	AMC50H-CA-V	AMC75H-CA-V	AMC100H-CA-V	-	-
AMC□H-CA-V-ES	-	-	AMC75H-CA-V-ES	AMC100H-CA-V-ES	-	-
AMC□H-DB	AMC25H-DB	AMC50H-DB	AMC75H-DB	AMC100H-DB	-	-
AMC□H-DB-V	AMC25H-DB-V	AMC50H-DB-V	AMC75H-DB-V	AMC100H-DB-V	-	-
AMC□H-CC	AMC25H-CC	AMC50H-CC	AMC75H-CC	AMC100H-CC	AMC125H-CC	AMC150H-CC
AMC□H-CC-V	AMC25H-CC-V	AMC50H-CC-V	AMC75H-CC-V	AMC100H-CC-V	AMC125H-CC-V	AMC150H-CC-V
AMC□H-CC-V-ES	AMC25H-CC-V-ES	AMC50H-CC-V-ES	AMC75H-CC-V-ES	AMC100H-CC-V-ES	AMC125H-CC-V-ES	AMC150H-CC-V-ES

### Technical parameters

Model	Rated air supply pressure bar	Max. vacuum level -kPa	Max. vacuum flow NL/min	Air consumption NL/min	Noise level dB(A)	Working temperature °C	Weight g	Vacuum chamber volume cm <sup>3</sup>	Recommended hose dia. mm	
									Air supply port P	Vacuum port V
AMC25L	6.0	75	360	130	63~68	-10~80	430	140	φ8	φ25
AMC50L	6.0	75	710	260	63~68	-10~80	435	140	φ8	φ25
AMC75L	6.0	75	1,050	390	63~68	-10~80	625	245	φ10	φ32
AMC100L	6.0	75	1,410	520	63~68	-10~80	630	245	φ10	φ32
AMC125L	6.0	75	1,500	650	63~68	-10~80	825	352	φ12	φ32
AMC150L	6.0	75	1,690	780	63~68	-10~80	830	352	φ12	φ32
AMC25H	5.0	95	354	135	63~68	-10~80	430	140	φ8	φ25
AMC50H	5.0	95	700	270	63~68	-10~80	435	140	φ8	φ25
AMC75H	5.0	95	980	405	63~68	-10~80	625	245	φ10	φ32
AMC100H	5.0	95	1,380	540	63~68	-10~80	630	245	φ10	φ32
AMC125H	5.0	95	1,480	675	63~68	-10~80	825	352	φ12	φ32
AMC150H	5.0	95	1,650	810	63~68	-10~80	830	352	φ12	φ32

### Vacuum flow(NL/min) at different vacuum levels(-kPa)

Model	Air supply pressure bar	Air consumption NL/min	Vacuum level (-kPa)								Max. vacuum level -kPa
			0	10	20	30	40	50	60	70	
AMC25L	6.0	130	360	210	156	102	54	36	30	21	75
AMC50L	6.0	260	710	420	312	204	108	72	60	42	75
AMC75L	6.0	390	1,050	630	468	306	162	108	90	66	75
AMC100L	6.0	520	1,410	840	624	408	216	144	120	84	75
AMC125L	6.0	650	1,500	948	744	510	270	180	150	126	75
AMC150L	6.0	780	1,690	1,074	888	612	324	216	180	132	75

# AMC Series

## Multistage Vacuum Generator



### Evacuation time(s/L) to reach different vacuum levels(-kPa)

Model	Air supply pressure bar	Air consumption NL/min	10	20	30	40	50	60	70	Max. vacuum level -kPa
AMC25L	6.0	130	0.020	0.050	0.100	0.180	0.330	0.530	0.800	75
AMC50L	6.0	260	0.010	0.025	0.050	0.090	0.170	0.270	0.400	75
AMC75L	6.0	390	0.007	0.017	0.033	0.060	0.110	0.180	0.270	75
AMC100L	6.0	520	0.005	0.013	0.025	0.045	0.083	0.130	0.200	75
AMC125L	6.0	650	0.005	0.012	0.022	0.036	0.066	0.110	0.160	75
AMC150L	6.0	780	0.004	0.010	0.018	0.030	0.055	0.090	0.130	75

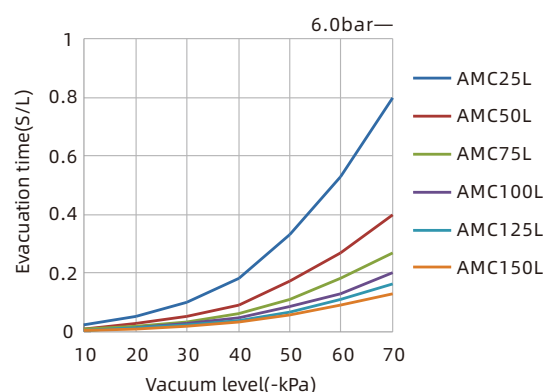
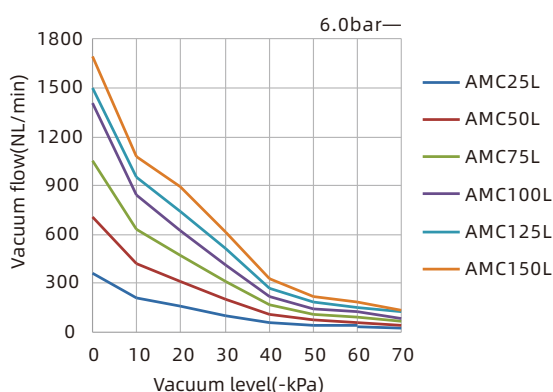

### Vacuum flow(NL/min) at different vacuum levels(-kPa)

Model	Air supply pressure bar	Air consumption NL/min	0	10	20	30	40	50	60	70	80	90	Max. vacuum level -kPa
AMC25H	5.0	135	354	180	120	78	43.8	34.8	25.8	19.2	10.8	1.8	95
AMC50H	5.0	270	700	360	240	156	87.6	69.6	51.6	38.4	21.6	3.6	95
AMC75H	5.0	405	980	540	360	234	131.4	104.4	77.4	57.6	32.4	5.4	95
AMC100H	5.0	540	1,380	720	480	312	175.2	139.2	103.2	76.8	43.2	7.2	95
AMC125H	5.0	675	1,480	810	570	390	219.0	174.0	129.0	96.0	54.0	9.0	95
AMC150H	5.0	810	1,650	918	684	468	262.8	206.4	154.8	115.2	64.8	10.8	95

### Evacuation time(s/L) to reach different vacuum levels(-kPa)

Model	Air supply pressure bar	Air consumption NL/min	10	20	30	40	50	60	70	80	90	Max. vacuum level -kPa
AMC25H	5.0	135	0.022	0.062	0.120	0.220	0.37	0.57	0.84	1.20	2.20	95
AMC50H	5.0	270	0.011	0.031	0.060	0.110	0.19	0.29	0.42	0.60	1.10	95
AMC75H	5.0	405	0.007	0.021	0.040	0.070	0.12	0.19	0.28	0.40	0.73	95
AMC100H	5.0	540	0.006	0.016	0.030	0.055	0.09	0.14	0.21	0.30	0.55	95
AMC125H	5.0	675	0.005	0.014	0.026	0.044	0.07	0.11	0.17	0.24	0.44	95
AMC150H	5.0	810	0.005	0.012	0.022	0.040	0.06	0.10	0.14	0.20	0.37	95

# AMC Series

## Multistage Vacuum Generator

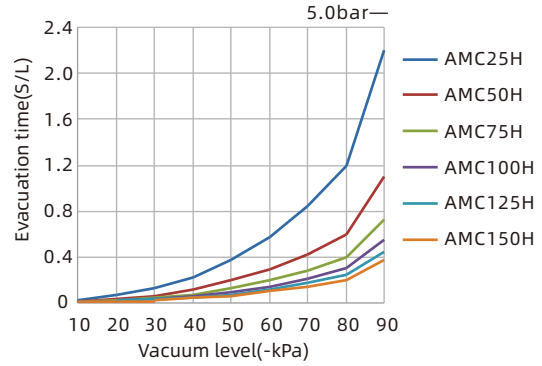
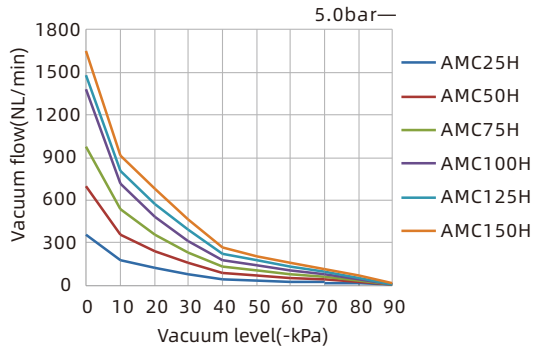

### Dimensions(mm)

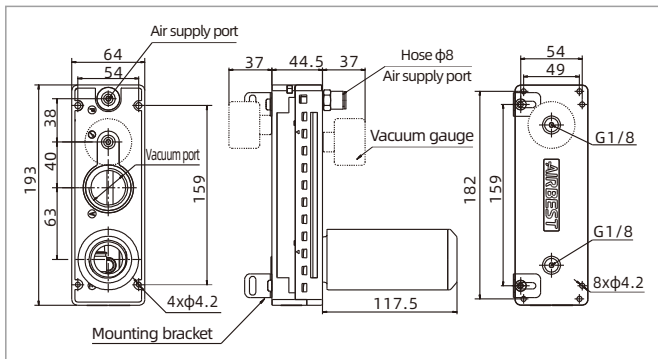

AMC25-50

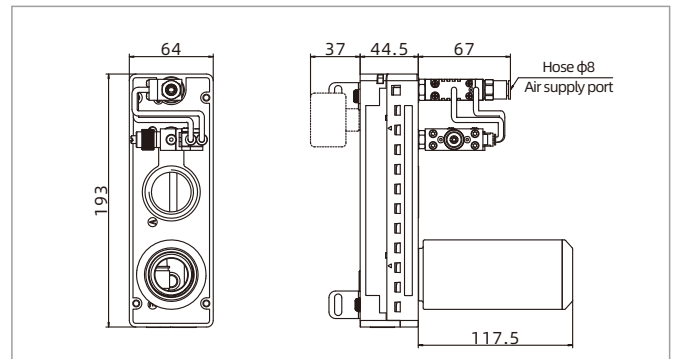

AMC25□-□-V-ES AMC50□-□-V-ES

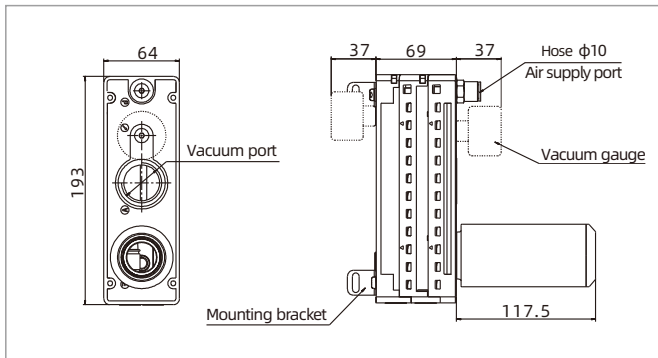

AMC75-100

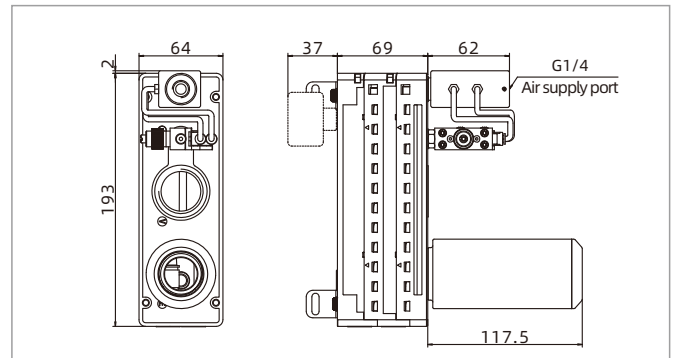

AMC75□-□-V-ES AMC100□-□-V-ES

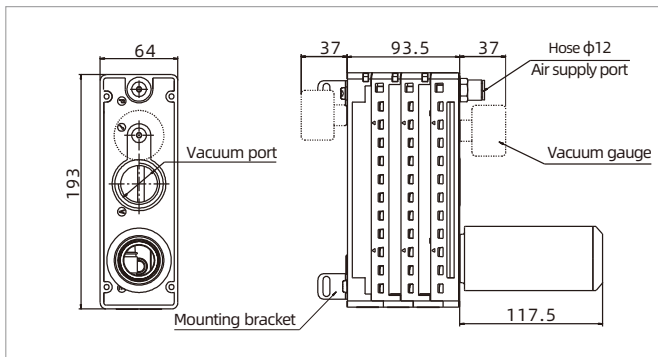

AMC125-150

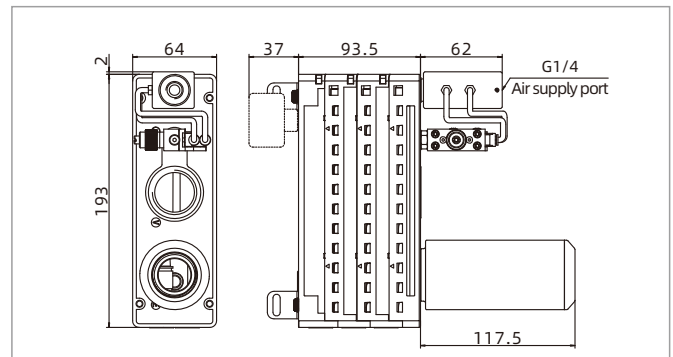

AMC125□-□-V-ES AMC150□-□-V-ES

Vacuum Generator

- AZK
- AZQ
- AZX
- AZD
- AGS
- AGP
- AGX
- AGE
- ABM/ABX
- ABM/ABX Combined Type
- AMC**
- AM/AL/AH
- AM/AL Combined Type
- AMD
- AZW
- AZR
- ABT
- ABP
- ABQ
- AEVC
- AZL
- ALH
- AZH
- AZU
- ACV
- ASBP
- ALS
- ACP
- ACPF
- ACPS
- APB

# AMC Series

## Multistage Vacuum Generator

### Dimensions(mm)

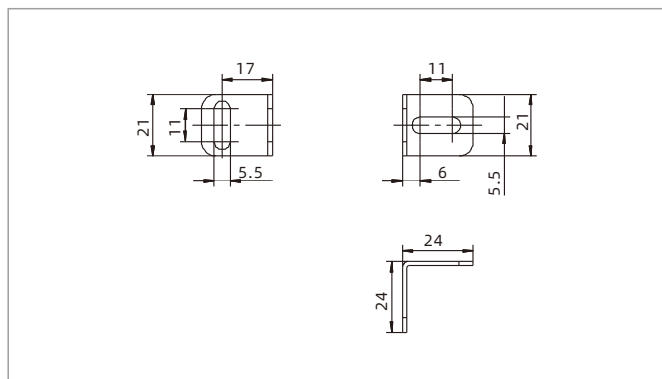

L type mounting bracket

### Air circuit schematic diagram

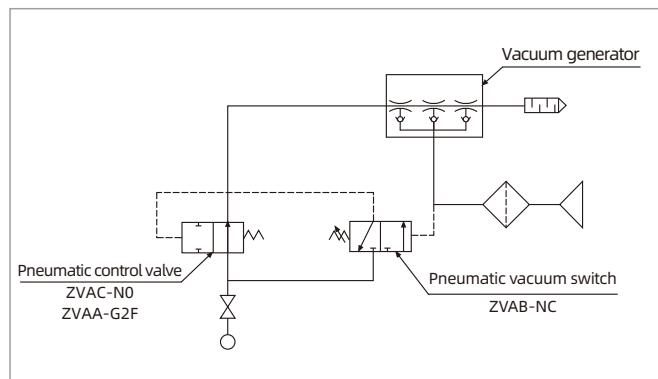

ES Energy saving system

### Accessory selection

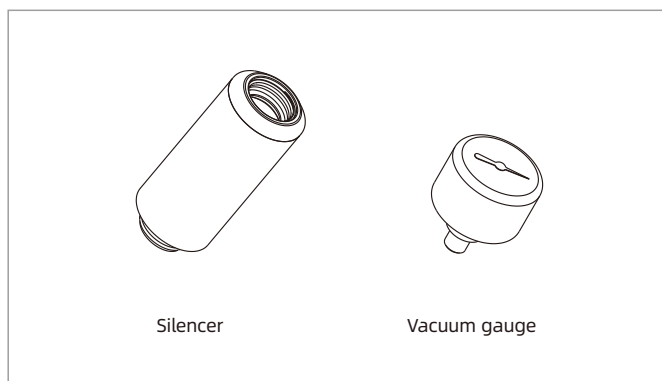

Silencer

Vacuum gauge

Mounting accessories

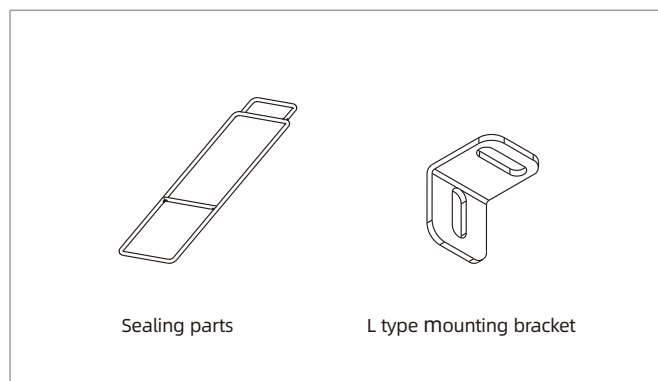

Sealing parts

L type mounting bracket

Mounting accessories

Item	Model	Remark
Silencer	ZSA-G8M	-
Vacuum gauge	ZPMR-V	-
Sealing ring	AMC50-R6	AMC25, 50/1 AMC75, 100/2 AMC125, 150/3
Mounting accessory kit	AMC50-R(2 brackets + 4 Screws + 1 $\phi$ 8 one-touch fitting)	AMC25, 50-AA
Mounting accessory kit	AMC100-R(2 brackets+ 4 Screws + 1 $\phi$ 10 one-touch fitting)	AMC25, 50, 75, 100-CA / AMC25, 50, 75, 100-CC
Mounting accessory kit	AMC150-R(2 brackets + 4 Screws + 1 $\phi$ 12 one-touch fitting)	AMC125, 150-CC

◇ Note: The mounting accessory kit includes 2 L-type brackets and 4 screws for the connection plate BA and DB

# AM/AL/AH Series

## Multistage Vacuum Generator

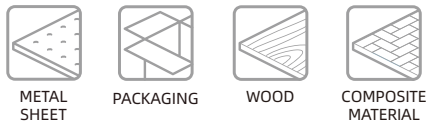

### Features

- ◇ Energy-efficient multistage nozzle design
- ◇ It has a very strong suction capacity
- ◇ A variety of specifications of air supply port and vacuum port
- ◇ Energy-saving system(ES) is optional

### Advantages

- ◇ Quick evacuation in low vacuum level range, reduce cost and shorten working cycle
- ◇ It can produce large vacuum flow, handle all porous workpieces fast and safely
- ◇ Different thread specifications can be used
- ◇ Save compressed air consumption when handling airtight workpieces



### Applications

- ◇ The multistage vacuum generator is suitable for handling cartons, packaging materials and porous materials
- ◇ Used for working conditions requiring large vacuum flow, fast evacuation and less air consumption

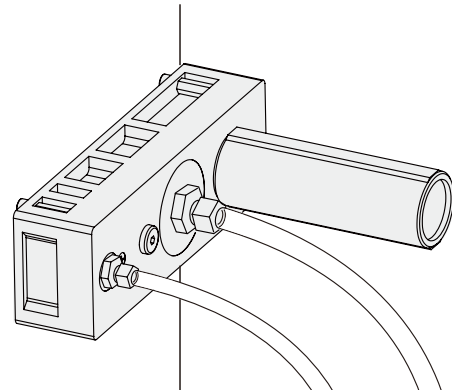

### Structure

- ◇ (1) The main body
- ◇ (2) Vacuum detecting port
- ◇ (3) Silencer
- ◇ (4) Air supply port
- ◇ (5) Mounting bracket
- ◇ (6) ES Energy-saving system

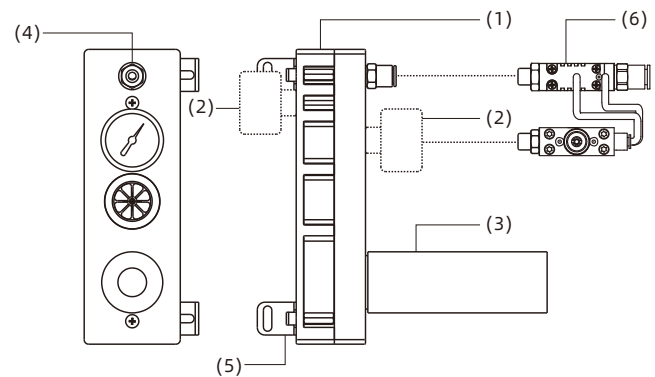

Vacuum Generator

- AZK
- AZQ
- AZX
- AZD
- AGS
- AGP
- AGX
- AGE
- ABM/ABX
- ABM/ABX Combined Type
- AMC
- AM/AL/AH**
- AM/AL Combined Type
- AMD
- AZW
- AZR
- ABT
- ABP
- ABQ
- AEVC
- AZL
- ALH
- AZH
- AZU
- ACV
- ASBP
- ALS
- ACP
- ACPF
- ACPS
- APB

# AM/AL/AH Series

## Multistage Vacuum Generator

### How to order

**AM 25L - AD - N - A - ES**  
 ①      ②      ③      ④      ⑤      ⑥

① Series	② Specification	③ Connection plate	④ Sealing	⑤ Non-return valve	⑥ Control device
AM - Universal type (-92kPa)	25L 50L 75L 100L 125L 150L	D B	N - NBR E - EPDM	Nil - Default, without non-return valve A - With non-return valve	Nil - Default, without control device
AL - Large vacuum flow type (-81kPa)	25 50 75 100 125 150	AD E	F - Fluorine rubber		PVD - Supply valve + Break valve
AH - High vacuum level type (-100.8kPa)	40 120	(Refer to table1)			ES - Energy-saving system only for AM-25L/50L AL-25/50 AH-40

◇ Note: When -A non-return valve or -ES energy-saving system is selected, the vacuum filter is needed.

### Connection plate table 1

Connection plate	Air supply port <sup>(1)</sup>	Vacuum port <sup>(2)</sup>	Exhaust port <sup>(3)</sup>	Connection plate material	Applicable vacuum generator
D	NPSF1/8	G3/4	G3/4	PPS	AM25-100、AL25-100、AH40-120
B	NPSF1/8	NPT3/4	NPT3/4	PPS	
AD	G1/4	G3/4	G3/4	Aluminum alloy	
E	NPT1/4	NPT3/4	NPT3/4	Aluminum alloy	
D	G1/4	G1"	G1"	PPS	AM125-150、AL125-150
B	NPT1/4	NPT1"	NPT1"	PPS	
AD	G1/4	G1"	G1"	Aluminum alloy	
E	NPT1/4	NPT1"	NPT1"	Aluminum alloy	

### Selection - AM series

Model/ Specification	25L	50L	75L	100L	125L	150L
AM□-D-N	AM25L-D-N	AM50L-D-N	AM75L-D-N	AM100L-D-N	AM125L-D-N	AM150L-D-N
AM□-D-N-A	AM25L-D-N-A	AM50L-D-N-A	AM75L-D-N-A	AM100L-D-N-A	AM125L-D-N-A	AM150L-D-N-A
AM□-D-N-A-ES	AM25L-D-N-A-ES	AM50L-D-N-A-ES	-	-	-	-
AM□-B-N	AM25L-B-N	AM50L-B-N	AM75L-B-N	AM100L-B-N	AM125L-B-N	AM150L-B-N
AM□-B-N-A	AM25L-B-N-A	AM50L-B-N-A	AM75L-B-N-A	AM100L-B-N-A	AM125L-B-N-A	AM150L-B-N-A
AM□-AD-N	AM25L-AD-N	AM50L-AD-N	AM75L-AD-N	AM100L-AD-N	AM125L-AD-N	AM150L-AD-N
AM□-AD-N-A	AM25L-AD-N-A	AM50L-AD-N-A	AM75L-AD-N-A	AM100L-AD-N-A	AM125L-AD-N-A	AM150L-AD-N-A
AM□-AD-N-A-ES	AM25L-AD-N-A-ES	AM50L-AD-N-A-ES	-	-	-	-
AM□-E-N	AM25L-E-N	AM50L-E-N	AM75L-E-N	AM100L-E-N	AM125L-E-N	AM150L-E-N
AM□-E-N-A	AM25L-E-N-A	AM50L-E-N-A	AM75L-E-N-A	AM100L-E-N-A	AM125L-E-N-A	AM150L-E-N-A
AM□-E-N-PVD	AM25L-E-N-PVD	AM50L-E-N-PVD	AM75L-E-N-PVD	AM100L-E-N-PVD	AM125L-E-N-PVD	AM150L-E-N-PVD

# AM/AL/AH Series

## Multistage Vacuum Generator



### Selection - AL series

Model/ Specification	25	50	75	100	125	150
AL□-D-N	AL25-D-N	AL50-D-N	AL75-D-N	AL100-D-N	AL125-D-N	AL150-D-N
AL□-D-N-A	AL25-D-N-A	AL50-D-N-A	AL75-D-N-A	AL100-D-N-A	AL125-D-N-A	AL150-D-N-A
AL□-D-N-A-ES	AL25-D-N-A-ES	AL50-D-N-A-ES	-	-	-	-
AL□-B-N	AL25-B-N	AL50-B-N	AL75-B-N	AL100-B-N	AL125-B-N	AL150-B-N
AL□-B-N-A	AL25-B-N-A	AL50-B-N-A	AL75-B-N-A	AL100-B-N-A	AL125-B-N-A	AL150-B-N-A
AL□-AD-N	AL25-AD-N	AL50-AD-N	AL75-AD-N	AL100-AD-N	AL125-AD-N	AL150-AD-N
AL□-AD-N-A	AL25-AD-N-A	AL50-AD-N-A	AL75-AD-N-A	AL100-AD-N-A	AL125-AD-N-A	AL150-AD-N-A
AL□-AD-N-A-ES	AL25-AD-N-A-ES	AL50-AD-N-A-ES	-	-	-	-
AL□-E-N	AL25-E-N	AL50-E-N	AL75-E-N	AL100-E-N	AL125-E-N	AL150-E-N
AL□-E-N-A	AL25-E-N-A	AL50-E-N-A	AL75-E-N-A	AL100-E-N-A	AL125-E-N-A	AL150-E-N-A
AL□-E-N-PVD	AL25-E-N-PVD	AL50-E-N-PVD	AL75-E-N-PVD	AL100-E-N-PVD	AL125-E-N-PVD	AL150-E-N-PVD

### Selection - AH series

Model/ Specification	40	120
AH□-D-N	AH40-D-N	AH120-D-N
AH□-D-N-A	AH40-D-N-A	AH120-D-N-A
AH□-D-N-A-ES	AH40-D-N-A-ES	-
AH□-B-N	AH40-B-N	AH120-B-N
AH□-B-N-A	AH40-B-N-A	AH120-B-N-A
AH□-AD-N	AH40-AD-N	AH120-AD-N
AH□-AD-N-A	AH40-AD-N-A	AH120-AD-N-A
AH□-AD-N-A-ES	AH40-AD-N-A-ES	-
AH□-E-N	AH40-E-N	AH120-E-N
AH□-E-N-A	AH40-E-N-A	AH120-E-N-A
AH□-E-N-PVD	AH40-E-N-PVD	AH120-E-N-PVD

### Technical parameters

Model	Rated air supply pressure bar	Max. vacuum level -kPa	Max. vacuum flow NL/min	Air consumption NL/min	Noise level dB(A)	Working temperature °C	Weight g	Recommended hose dia. mm	
								(Hose outer dia.) Air supply port	(Wired hose inner dia.) Vacuum port
AL25	6.0	81	360	105	81	-10~80	675	φ8	φ19
AL50	6.0	81	640	215	81	-10~80	675	φ10	φ19
AL75	6.0	81	850	320	81	-10~80	837	φ10	φ25
AL100	6.0	81	990	390	82	-10~80	837	φ10	φ25
AL125	6.0	81	1,170	480	82	-10~80	1,075	φ12	φ32
AL150	6.0	81	1,230	620	81	-10~80	1,075	φ12	φ32
AH40	6.0	99.8	150	155	81	-10~80	675	φ10	φ19
AH120	6.0	100.8	530	440	81	-10~80	837	φ12	φ19

Vacuum Generator

AZK

AZQ

AZX

AZD

AGS

AGP

AGX

AGE

ABM/ABX

ABM/ABX  
Combined Type

AMC

AM/AL/AH

AM/AL  
Combined Type

AMD

AZW

AZR

ABT

ABP

ABQ

AEVC

AZL

ALH

AZH

AZU

ACV

ASBP

ALS

ACP

ACPF

ACPS

APB

# AM/AL/AH Series

## Multistage Vacuum Generator



### Technical parameters

Model	Rated air supply pressure bar	Max. vacuum level -kPa	Max. vacuum flow NL/min	Air consumption NL/min	Noise level dB(A)	Working temperature °C	Weight g	Recommended hose dia. mm (Hose outer dia.)	Recommended hose dia. mm (Wired hose inner dia.)	Vacuum port
AM25L	3.4	92	360	116	80	-10~80	675	φ8		φ19
AM50L	3.4	92	600	230	81	-10~80	675	φ8		φ19
AM75L	3.4	92	760	365	81	-10~80	837	φ10		φ25
AM100L	3.4	92	850	445	81	-10~80	837	φ10		φ25
AM125L	3.4	92	1,150	545	82	-10~80	1,075	φ12		φ32
AM150L	3.4	92	1,200	655	82	-10~80	1,075	φ12		φ32
AM25L	6.0	89	420	185	80	-10~80	675	φ8		φ19
AM50L	6.0	89	700	370	81	-10~80	675	φ8		φ19
AM75L	6.0	89	950	610	81	-10~80	837	φ10		φ25
AM100L	6.0	89	1,010	720	81	-10~80	837	φ10		φ25
AM125L	6.0	89	1,400	780	82	-10~80	1,075	φ12		φ32
AM150L	6.0	89	1,500	810	82	-10~80	1,075	φ12		φ32

### Vacuum flow(NL/min) at different vacuum levels(-kPa)

Model	Air supply pressure bar	Air consumption NL/min	0	10	20	30	40	50	60	70	80	90	Max. vacuum level -kPa
AM25L	3.4	116	360	180	115	80	43	30	22.5	15.5	7.5	1.2	92
AM50L	3.4	230	600	320	250	135	75	60	46	30	13	1.5	92
AM75L	3.4	365	760	445	340	175	110	85	70	43	20	1.8	92
AM100L	3.4	445	850	550	430	280	145	115	85	60	28	2.2	92
AM125L	3.4	545	1,150	760	530	350	180	148	115	78	34.5	3.5	92
AM150L	3.4	655	1,200	830	550	360	215	170	130	90	36	5	92
AM25L	6.0	185	420	240	125	100	82	65	38	12.5	3.5	-	89
AM50L	6.0	370	700	510	290	195	160	115	70	22	8	-	89
AM75L	6.0	610	950	710	380	285	230	170	100	32	11	-	89
AM100L	6.0	720	1,010	800	460	385	310	215	125	42	15.5	-	89
AM125L	6.0	780	1,400	1,120	560	490	355	260	150	50	25	-	89
AM150L	6.0	810	1,500	1,110	630	560	385	315	210	65	26	-	89

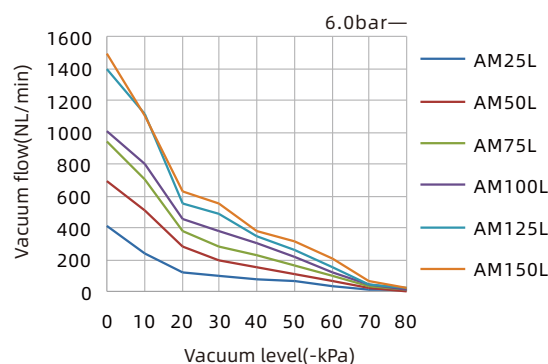
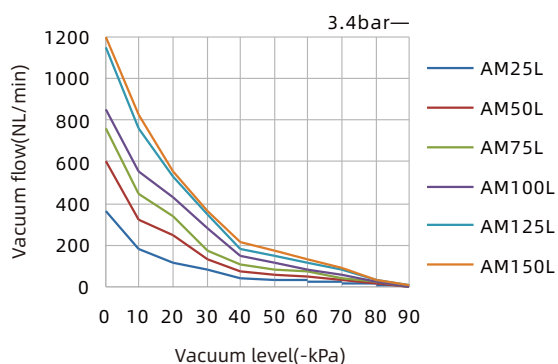

# AM/AL/AH Series

## Multistage Vacuum Generator



### Evacuation time(s/L) to reach different vacuum levels(-kPa)

Model	Air supply pressure bar	Air consumption NL/min	10	20	30	40	50	60	70	80	90	Max. vacuum level -kPa
AM25L	3.4	116	0.022	0.060	0.110	0.210	0.400	0.650	0.950	1.600	4.000	92
AM50L	3.4	230	0.014	0.031	0.060	0.100	0.200	0.340	0.500	0.800	2.500	92
AM75L	3.4	365	0.012	0.029	0.058	0.095	0.180	0.310	0.460	0.890	1.500	92
AM100L	3.4	445	0.010	0.025	0.043	0.075	0.110	0.190	0.270	0.450	1.200	92
AM125L	3.4	545	0.006	0.015	0.029	0.052	0.085	0.145	0.202	0.330	1.00	92
AM150L	3.4	655	0.005	0.013	0.027	0.045	0.070	0.105	0.230	0.460	0.900	92
AM25L	6.0	185	0.018	0.050	0.080	0.018	0.250	0.400	0.620	1.550	-	89
AM50L	6.0	370	0.010	0.022	0.048	0.080	0.110	0.200	0.350	0.780	-	89
AM75L	6.0	610	0.009	0.019	0.045	0.075	0.130	0.180	0.310	0.700	-	89
AM100L	6.0	720	0.007	0.018	0.038	0.055	0.080	0.120	0.190	0.470	-	89
AM125L	6.0	780	0.005	0.013	0.026	0.045	0.062	0.115	0.194	0.560	-	89
AM150L	6.0	810	0.003	0.009	0.014	0.03	0.060	0.095	0.200	0.800	-	89

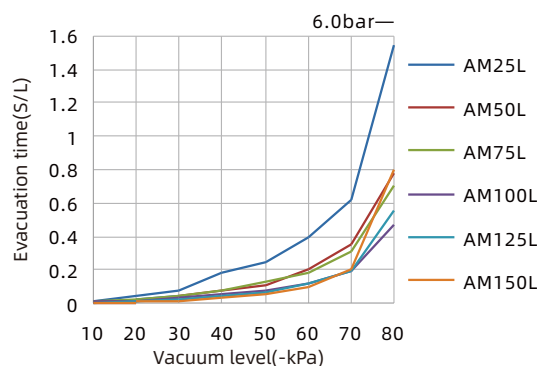
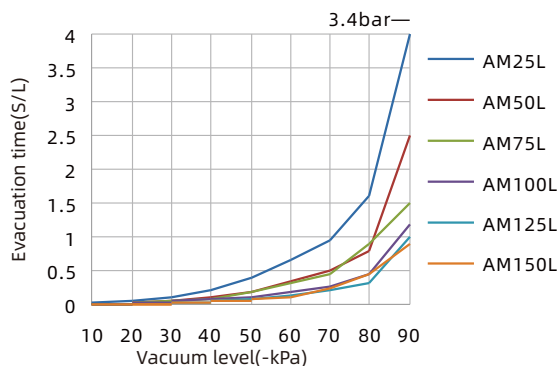

### Vacuum flow(NL/min) at different vacuum levels(-kPa)

Model	Air supply pressure bar	Air consumption NL/min	0	10	20	30	40	50	60	70	Max. vacuum level -kPa
AL25	6.0	105	360	196	135	85	45	36	27	17	81
AL50	6.0	215	640	320	205	145	95	65	45	25	81
AL75	6.0	320	850	430	320	190	130	105	65	40	81
AL100	6.0	390	990	580	460	300	185	130	95	52	81
AL125	6.0	480	1,170	720	541	350	200	150	125	65	81
AL150	6.0	620	1,230	760	560	410	210	160	148	85	81

Vacuum Generator

AZK  
AZQ  
AZX  
AZD  
AGS  
AGP  
AGX  
AGE

ABM/ABX  
ABM/ABX Combined Type  
AMC  
AM/AL/AH

AM/AL Combined Type  
AMD  
AZW  
AZR  
ABT

ABP  
ABQ

AEVC  
AZL  
ALH  
AZH  
AZU  
ACV  
ASBP

ALS  
ACP  
ACPF  
ACPS  
APB

# AM/AL/AH Series

## Multistage Vacuum Generator



### Evacuation time(s/L) to reach different vacuum levels(-kPa)

Model	Air supply pressure bar	Air consumption NL/min	10	20	30	40	50	60	70	Max. vacuum level -kPa
AL25	6.0	105	0.030	0.060	0.100	0.200	0.390	0.580	0.870	81
AL50	6.0	215	0.018	0.039	0.066	0.120	0.200	0.310	0.510	81
AL75	6.0	320	0.010	0.020	0.040	0.080	0.120	0.200	0.310	81
AL100	6.0	390	0.008	0.017	0.032	0.050	0.090	0.130	0.220	81
AL125	6.0	480	0.006	0.016	0.026	0.045	0.078	0.110	0.180	81
AL150	6.0	620	0.005	0.014	0.024	0.040	0.071	0.100	0.160	81

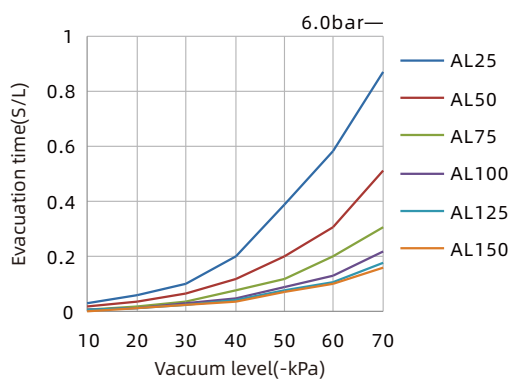
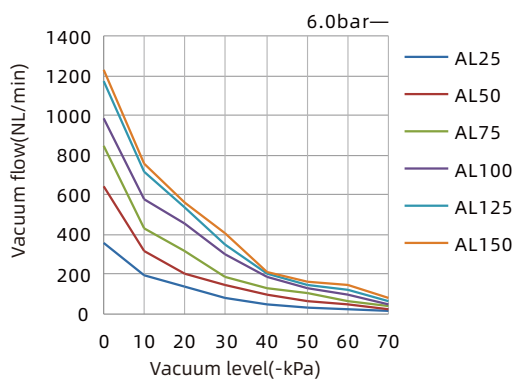

### Vacuum flow(NL/min) at different vacuum levels(-kPa)

Model	Air supply pressure bar	Air consumption NL/min	0	10	20	30	40	50	60	70	80	90	99	Max. vacuum level -kPa
AH40	6.0	155	150	145	105	52.5	27.5	20.5	15.0	8.5	5.5	3.0	0.2	99.8
AH120	6.0	440	530	420	265	141.0	85.0	65.0	45.0	33.0	21.5	6.0	0.5	100.8

### Evacuation time(s/L) to reach different vacuum levels(-kPa)

Model	Air supply pressure bar	Air consumption NL/min	10	20	30	40	50	60	70	80	90	99	Max. vacuum level -kPa
AH40	6.0	155	0.04	0.08	0.18	0.32	0.64	1.30	1.80	2.60	3.90	9.8	99.8
AH120	6.0	440	0.02	0.04	0.08	0.14	0.25	0.38	0.66	1.08	3.60	8.5	100.8

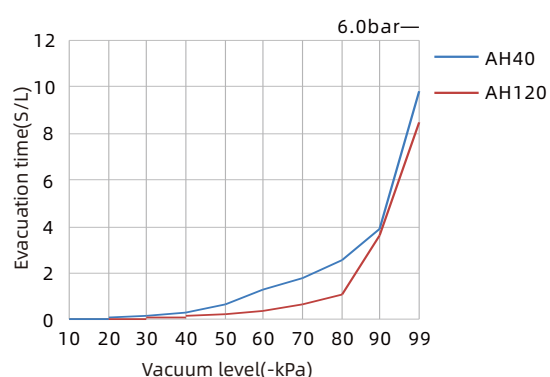
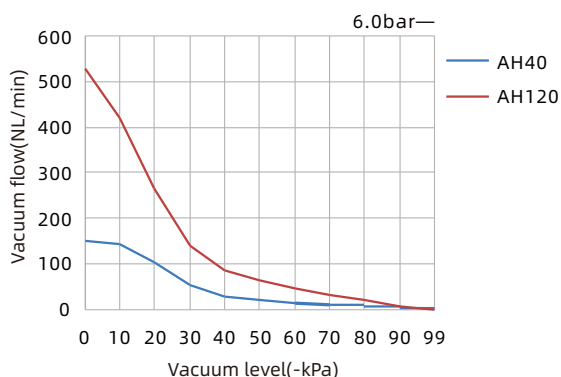

# AM/AL/AH Series

## Multistage Vacuum Generator



### Dimensions(mm)

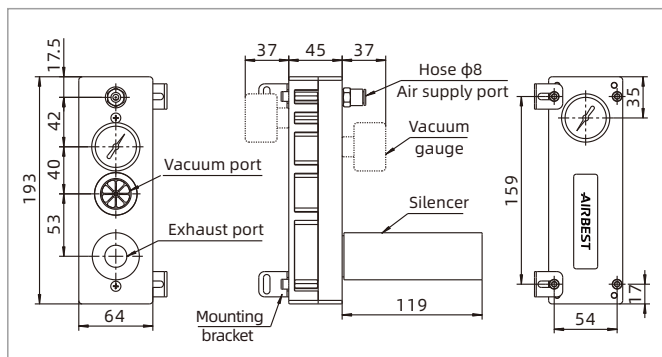

AM/AL25-50 AH40

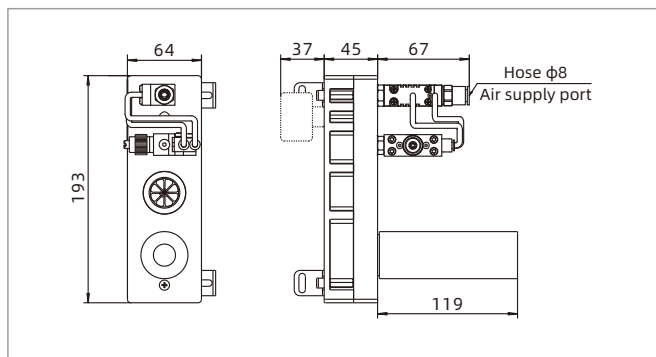

AM/AL25-50-N-A-ES

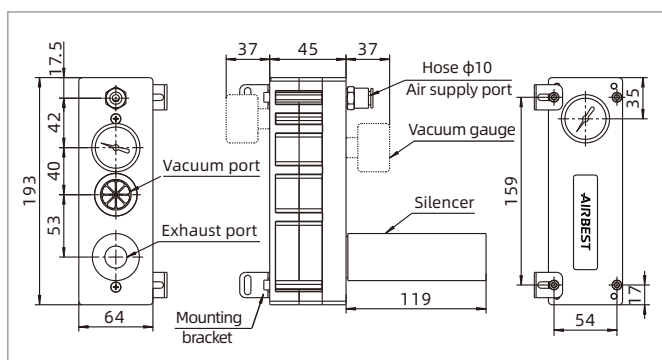

AM/AL75-100

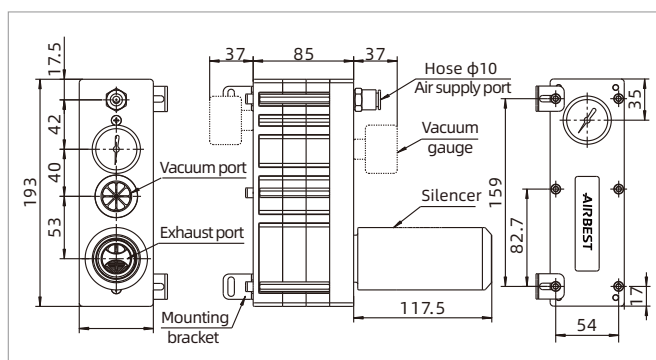

AM/AL125-150

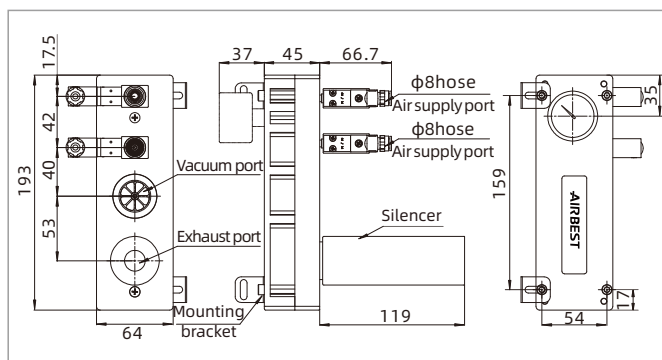

AM/AL25-50-D/B-PVD

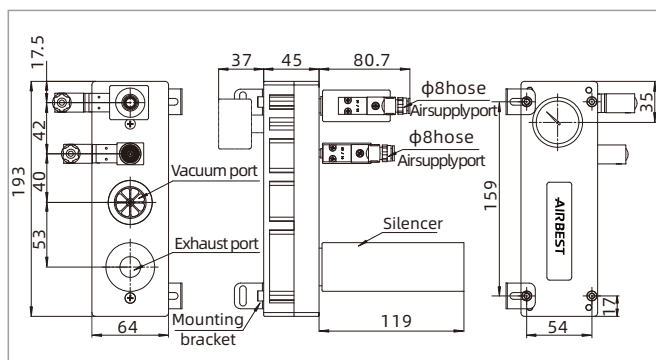

AM/AL25-50-AD/E-PVD

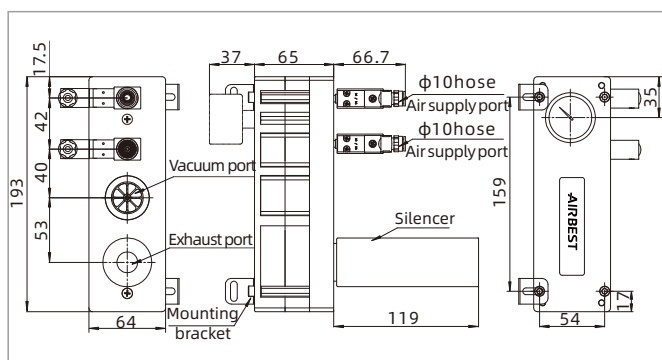

AM/AL75-100-D/B-PVD

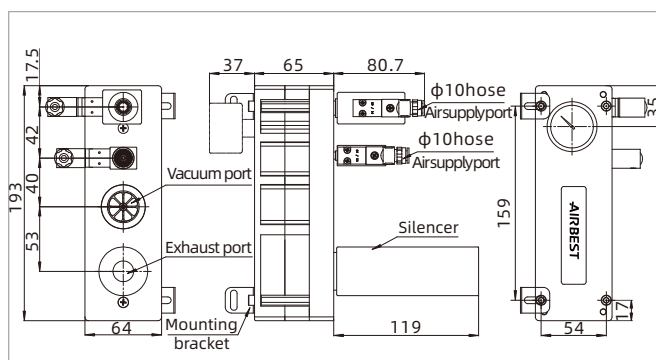

AM/AL75-100-AD/E-PVD

Vacuum Generator

AZK

AZQ

AZX

AZD

AGS

AGP

AGX

AGE

ABM/ABX

ABM/ABX  
Combined Type

AMC

AM/AL/AH

AM/AL  
Combined Type

AMD

AZW

AZR

ABT

ABP

ABQ

AEVC

AZL

ALH

AZH

AZU

ACV

ASBP

ALS

ACP

ACPF

ACPS

APB

# AM/AL/AH Series

## Multistage Vacuum Generator

### Dimensions(mm)

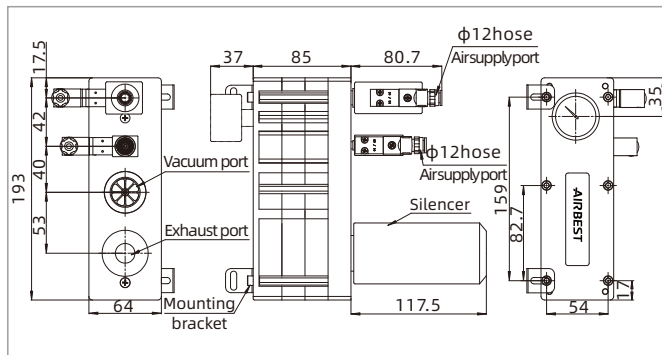

AM/AL125-150-□-□-PVD

# AM/AL/AH Series

## Multistage Vacuum Generator

### Dimensions(mm)

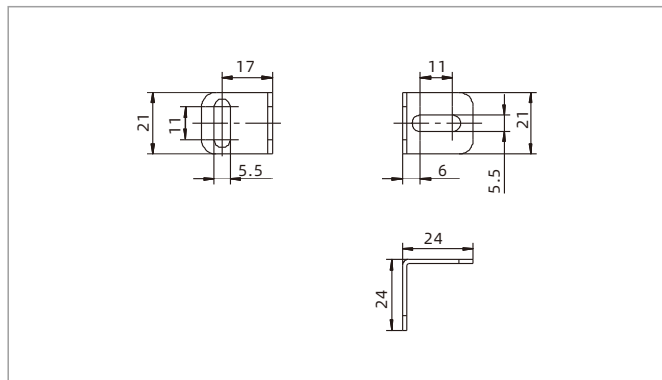

L type mounting bracket

### Air circuit schematic diagram

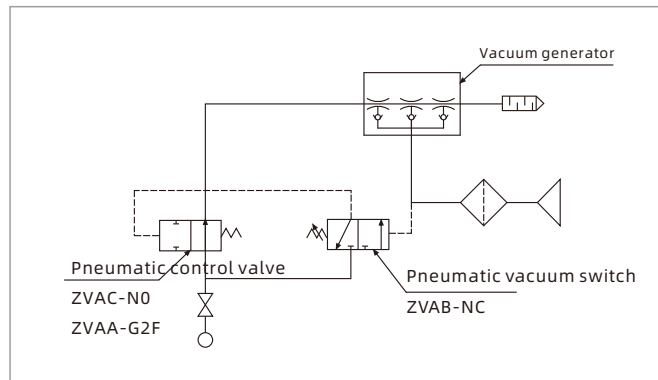

ES Energy-saving system

### Accessories

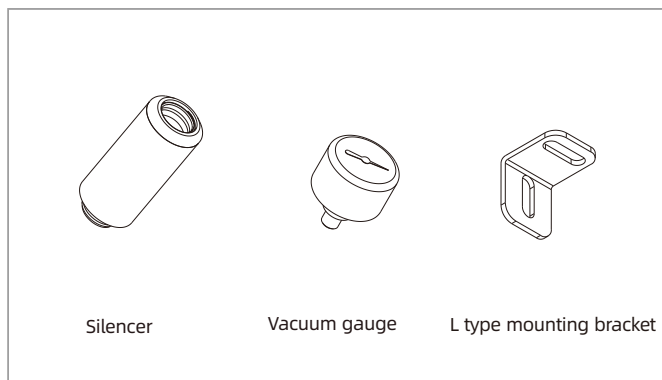

Mounting accessories

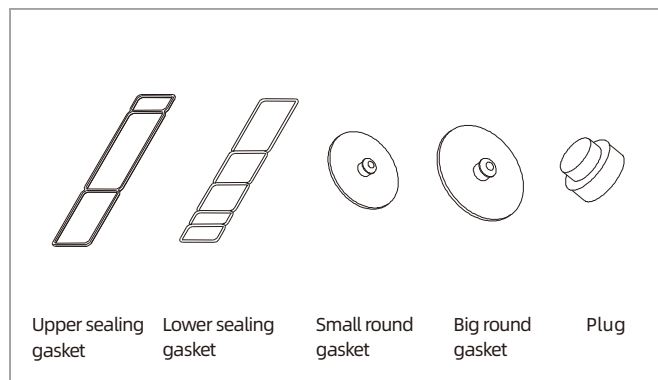

Repair kits-Sealing kits

Item	Model	Applicable vacuum generator
Silencer	ZSA-G6M	AM25-50, AL25-50, AH40
Vacuum gauge	ZPMR-V	AM25-50, AL25-50, AH40
Sealing kits	AM50L-PK (1 Upper sealing gasket+1 Lower sealing gasket+2 Small round gaskets+2 Plugs)	AM25-50, AL25-50, AH40
Mounting accessory kit	AM50L-D-R (2 brackets+4 screws+1 G1/8 φ8 one-touch fitting)	AM25-50, AL25-50, AH40
Mounting accessory kit	AM50L-E-R (2 brackets+4 screws+1 G1/4 φ8 one-touch fitting)	AM25-50, AL25-50, AH40
Silencer	ZSA-G6M	AM75-100, AL75-100, AH120
Vacuum gauge	ZPMR-V	AM75-100, AL75-100, AH120
Sealing kits	AM100L-PK (1 Upper sealing gasket+2 Lower sealing gaskets+2 Small round gaskets+4 Plugs)	AM75-100, AH120
Sealing kits	AL100-PK (1 Upper sealing gasket+2 Lower sealing gaskets+1 Small round gasket+1 Big round gasket+ 4 Plugs)	AL75-100
Mounting accessory kit	AM100L-D-R (2 brackets+4 screws+1 G1/8 φ10 one-touch fitting)	AM75-100, AL75-100, AH120
Mounting accessory kit	AM100L-E-R (2 brackets+4 screws+1 G1/4 φ10 one-touch fitting)	AM75-100, AL75-100, AH120
Silencer	ZSA-G8M	AM125-150, AL125-150
Vacuum gauge	ZPMR-V	AM125-150, AL125-150
Sealing kits	AM150L-PK (1 Upper sealing gasket+3 Lower sealing gaskets+1 Small round gasket+1 Big round gasket+6 Plugs)	AM125-150, AL125-150
Mounting accessory kit	AM150L-R (2 brackets+4 screws+1 G1/4 φ12 one-touch fitting)	AM125-150, AL125-150

◇ Note: The mounting accessory kit includes 2 L-type brackets and 4 screws for the connection plate B and E

# AM/AL Series



## Combined Type Multistage Vacuum Generator



METAL SHEET



PACKAGING



WOOD



COMPOSITE MATERIAL



### Features

- ◇ Energy-efficient multistage nozzle design
- ◇ It has a very strong suction capacity
- ◇ With mounting bracket
- ◇ External silencer

### Advantages

- ◇ Quick evacuation in low vacuum level range, reduce cost and shorten working cycle
- ◇ It can produce large vacuum flow, handle all porous workpieces fast and safely
- ◇ Easy installation and easy operation
- ◇ Reduce product noise greatly



### Applications

- ◇ The multistage large flow vacuum generator is suitable for handling cartons, packaging materials and porous materials
- ◇ Used in conveying systems, such as particulate matter, powder, etc
- ◇ Used for working conditions requiring large vacuum flow, fast evacuation and less air consumption

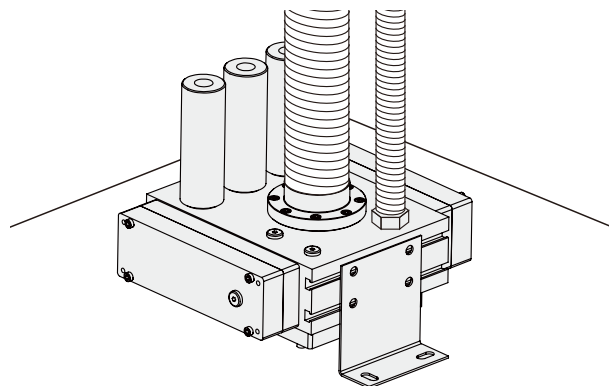

### Structure

- ◇ (1) Mounting hole for vacuum gauge
- ◇ (2) Mounting hole for positive pressure gauge
- ◇ (3) Vacuum port
- ◇ (4) Air supply port
- ◇ (5) Silencer

Standard

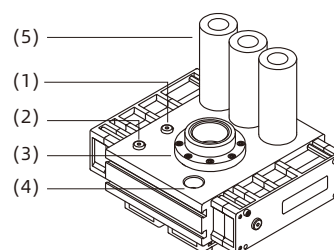

Lateral exhaust

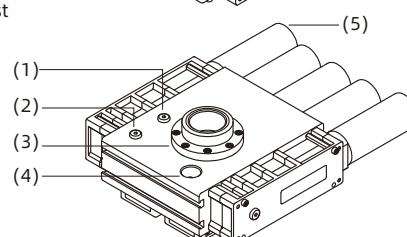

# AM/AL Series

## Combined Type Multistage Vacuum Generator

### How to order

## AM 200M P - N

①      ②      ③      ④

① Series	② Specification	③ Exhaust type	④ Sealing
AM - Universal type(-89kPa)	150M	Nil - Standard	N - NBR
AL - Large vacuum flow type(-81kPa)	200M	P - Lateral exhaust	E - EPDM
	300M		F - Fluorine rubber
	400M		
	500M		

### Selection - AM series

Model/ Specification	150	200	300	400	500
AM□M-N	AM150M-N	AM200M-N	AM300M-N	AM400M-N	AM500M-N
AM□MP-N	AM150MP-N	AM200MP-N	AM300MP-N	AM400MP-N	AM500MP-N

### Selection - AL series

Model/ Specification	150	200	300	400	500
AL□M-N	AL150M-N	AL200M-N	AL300M-N	AL400M-N	AL500M-N
AL□MP-N	AL150MP-N	AL200MP-N	AL300MP-N	AL400MP-N	AL500MP-N

### Technical parameters

Model	Rated air supply pressure bar	Max. vacuum level -kPa	Max. vacuum flow NL/min	Air consumption NL/min	Noise level dB(A)	Working temperature °C	Weight g	Recommended hose dia. mm (Hose outer dia.) Air supply port	Recommended hose dia. mm (Wired hose inner dia.) Vacuum port
AM150M	6.0	89	1,880	1,120	80	-10~80	3,724	φ16	φ32
AM200M	6.0	89	2,200	1,460	81	-10~80	3,892	φ16	φ32
AM300M	6.0	89	3,150	2,200	81	-10~80	5,525	φ16	φ45
AM400M	6.0	89	3,710	2,790	81	-10~80	6,447	φ16	φ45
AM500M	6.0	89	4,570	3,520	82	-10~80	7,929	φ16	φ60

Model	Rated air supply pressure bar	Max. vacuum level -kPa	Max. vacuum flow NL/min	Air consumption NL/min	Noise level dB(A)	Working temperature °C	Weight g	Recommended hose dia. mm (Hose outer dia.) Air supply port	Recommended hose dia. mm (Wired hose inner dia.) Vacuum port
AL150M	6.0	81	1,660	650	80	-10~80	3,724	φ16	φ32
AL200M	6.0	81	1,950	830	81	-10~80	3,892	φ16	φ32
AL300M	6.0	81	2,840	1,240	81	-10~80	5,525	φ21	φ45
AL400M	6.0	81	3,340	1,650	81	-10~80	6,447	φ21	φ45
AL500M	6.0	81	3,970	2,100	82	-10~80	7,929	φ16	φ60

## Combined Type Multistage Vacuum Generator

### Vacuum flow(NL/min) at different vacuum levels(-kPa)

Model	Air supply pressure bar	Air consumption NL/min	0	10	20	30	40	50	60	70	80	Max. vacuum level -kPa
AL150M	6.0	650	1,660	870	720	450	240	160	115	70	32	81
AL200M	6.0	830	1,950	1,140	870	520	305	230	160	105	38	81
AL300M	6.0	1,240	2,840	1,660	1,330	810	580	360	265	155	45	81
AL400M	6.0	1,650	3,340	2,200	1,730	1,110	630	590	370	225	80	81
AL500M	6.0	2,100	3,970	2,710	1,990	1,320	790	660	360	270	92	81

### Evacuation time(s/L) to reach different vacuum levels(-kPa)

Model	Air supply pressure bar	Air consumption NL/min	10	20	30	40	50	60	70	80	Max. vacuum level -kPa
AL150M	6.0	650	0.007	0.019	0.028	0.051	0.105	0.198	0.210	0.370	81
AL200M	6.0	830	0.005	0.013	0.023	0.040	0.060	0.098	0.150	0.300	81
AL300M	6.0	1,240	0.004	0.011	0.018	0.030	0.040	0.070	0.100	0.200	81
AL400M	6.0	1,650	0.003	0.008	0.010	0.150	0.030	0.060	0.080	0.150	81
AL500M	6.0	2,100	0.002	0.005	0.008	0.010	0.022	0.040	0.060	0.100	81

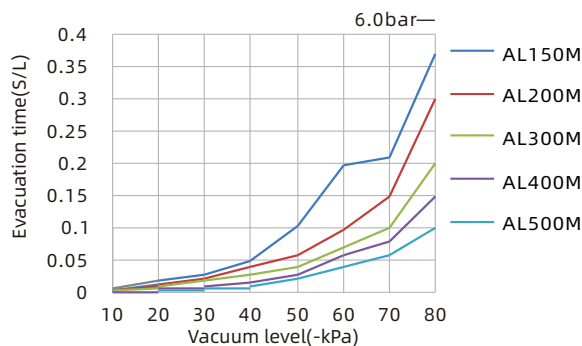
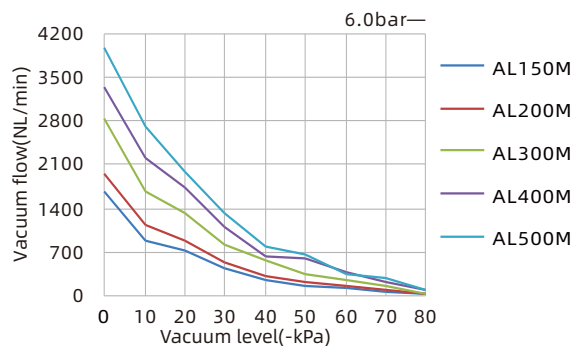

### Vacuum flow(NL/min) at different vacuum levels(-kPa)

Model	Air supply pressure bar	Air consumption NL/min	0	10	20	30	40	50	60	70	80	Max. vacuum level -kPa
AM150M	6.0	1,120	1,880	1,210	730	640	490	340	200	75	25	89
AM200M	6.0	1,460	2,200	1,490	930	800	650	490	245	85	11	89
AM300M	6.0	2,290	3,150	2,100	1,410	1,180	930	660	365	105	75	89
AM400M	6.0	2,790	3,710	2,480	1,800	1,450	1,100	870	370	195	80	89
AM500M	6.0	3,250	4,570	3,240	2,330	1,800	1,470	1,140	700	205	115	89

### Evacuation time(s/L) to reach different vacuum levels(-kPa)

Model	Air supply pressure bar	Air consumption NL/min	10	20	30	40	50	60	70	80	Max. vacuum level -kPa
AM150M	6.0	1,120	0.007	0.017	0.026	0.040	0.060	0.080	0.120	0.600	89
AM200M	6.0	1,460	0.005	0.012	0.022	0.030	0.040	0.060	0.110	0.330	89
AM300M	6.0	2,290	0.004	0.010	0.013	0.023	0.030	0.040	0.080	0.190	89

# AM/AL Series

## Combined Type Multistage Vacuum Generator



### Evacuation time(s/L) to reach different vacuum levels(-kPa)

Model	Air supply pressure bar	Air consumption NL/min	10	20	30	40	50	60	70	80	Max. vacuum level -kPa
AM400M	6.0	2,790	0.003	0.008	0.012	0.020	0.025	0.030	0.060	0.150	89
AM500M	6.0	3,250	0.002	0.005	0.008	0.015	0.020	0.027	0.050	0.120	89

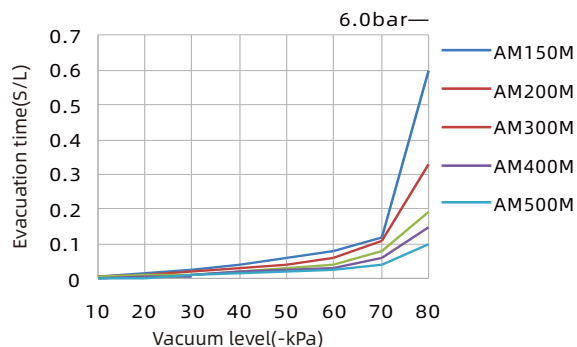
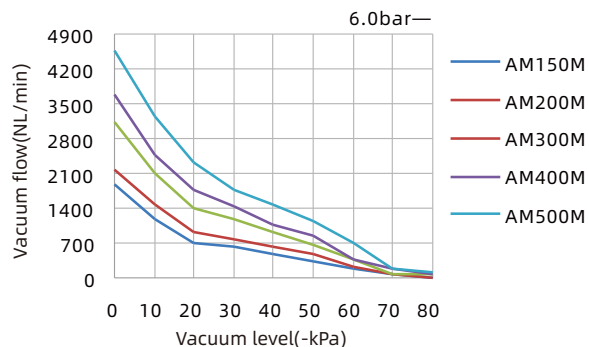

### Dimensions(mm)

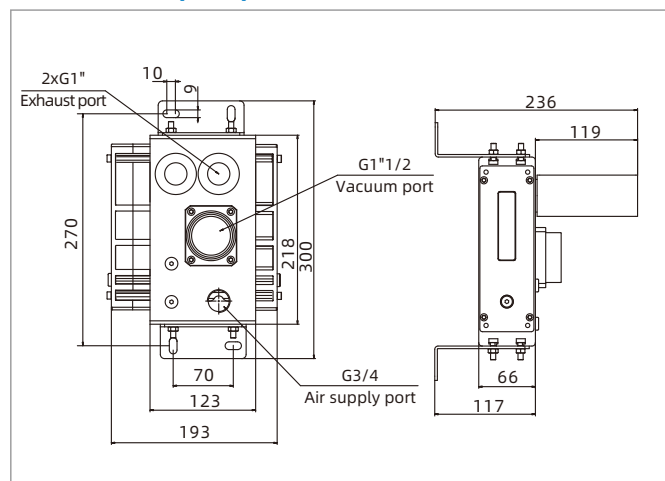

AM150M AL150M

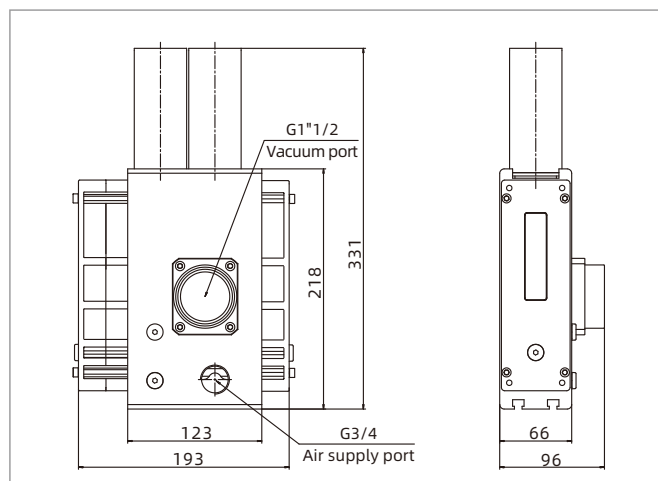

AM150MP AL150MP

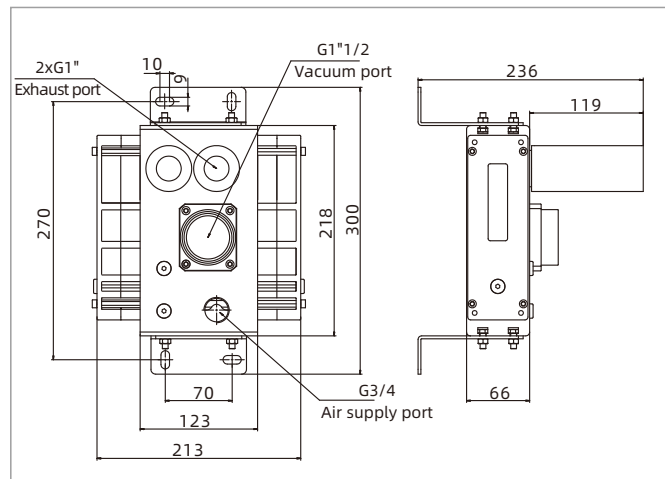

AM200M AL200M

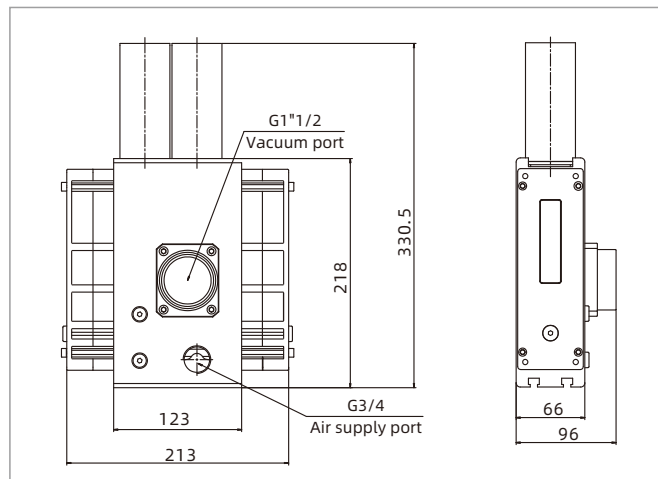

AM200MP AL200MP

Vacuum Generator

AZK

AZQ

AZX

AZD

AGS

AGP

AGX

AGE

ABM/ABX

ABM/ABX  
Combined Type

AMC

AM/AL/AH

AM/AL  
Combined Type

AMD

AZW

AZR

ABT

ABP

ABQ

AEVC

AZL

ALH

AZH

AZU

ACV

ASBP

ALS

ACP

ACPF

ACPS

APB

# AM/AL Series



## Combined Type Multistage Vacuum Generator

### Dimensions(mm)

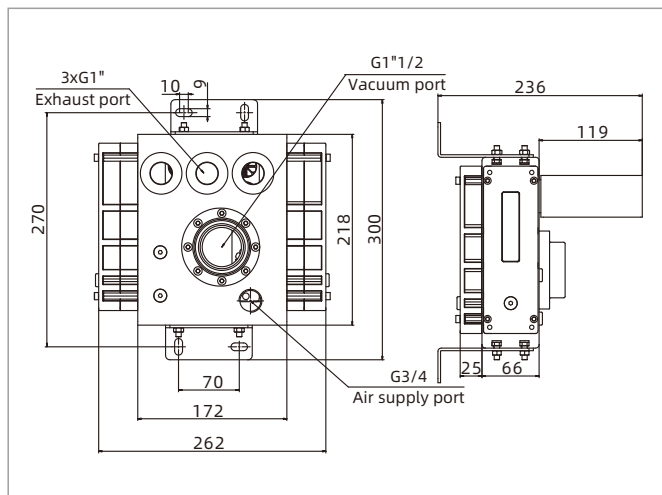

AM300M AL300M

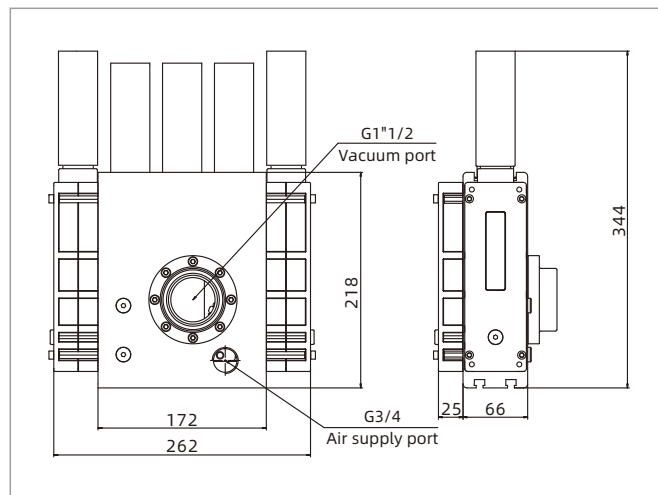

AM300MP AL300MP

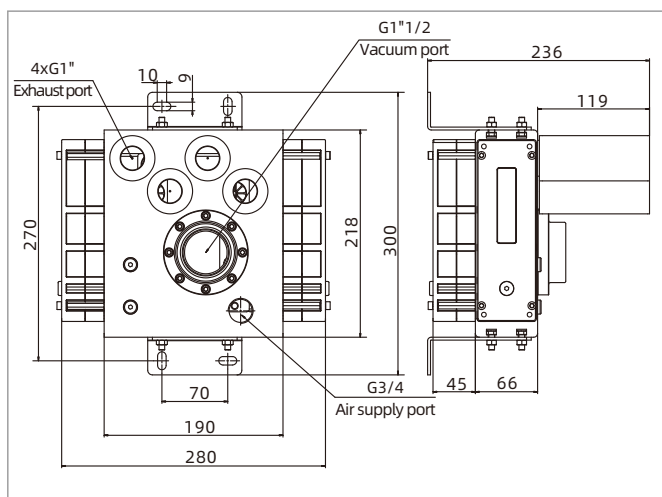

AM400M AL400M

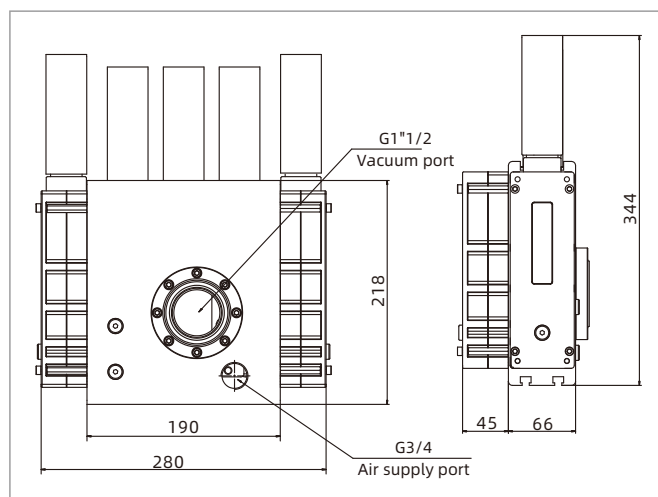

AM400MP AL400MP

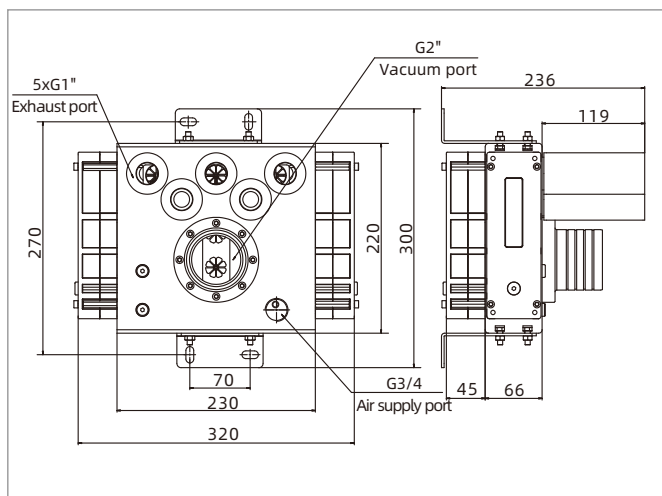

AM500M AL500M

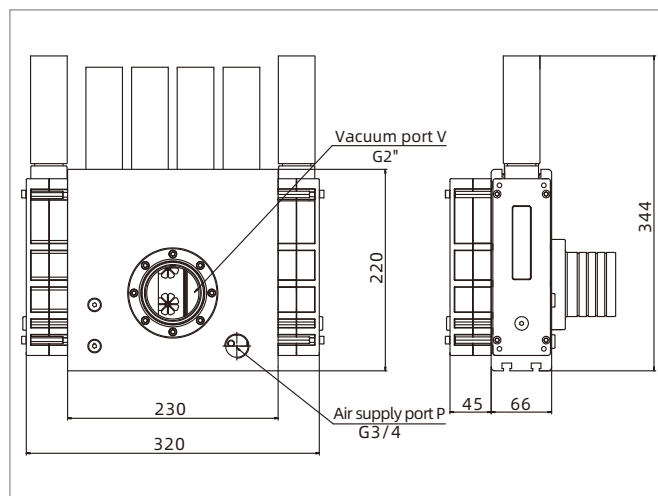

AM500MP AL500MP

# AMD Series

## Large Flow Vacuum Generator



UNIVERSAL



### Features

- ◇ Built-in vacuum cartridge, greatly improve the energy consumption ratio
- ◇ Suitable connection specifications can be configured according to different vacuum flow requirements
- ◇ Various connection specifications can meet different requirements

### Advantages

- ◇ Easy installation, easy maintenance, it can be replaced by users themselves
- ◇ Various connection specifications can meet different customized requirements
- ◇ Multistage vacuum generator, the housing is made of aluminum alloy



### Applications

- ◇ Suitable for multi-station vacuum grasping applications
- ◇ Suitable for vacuum evacuation occasions in pharmaceutical and food industry

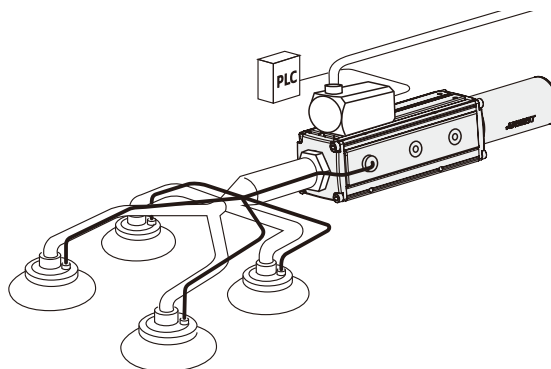

### Structure

- ◇ (1) Vacuum port
- ◇ (2) Release port
- ◇ (3) Air supply port
- ◇ (4) Vacuum port
- ◇ (5) Exhaust port
- ◇ (6) Silencer

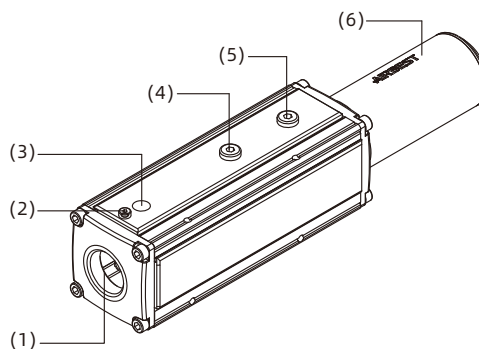

Vacuum Generator

AZK

AZQ

AZX

AZD

AGS

AGP

AGX

AGE

ABM/ABX

ABM/ABX  
Combined Type

AMC

AM/AL/AH

AM/AL  
Combined Type

**AMD**

AZW

AZR

ABT

ABP

ABQ

AEVC

AZL

ALH

AZH

AZU

ACV

ASBP

ALS

ACP

ACPF

ACPS

APB

# AMD Series

## Large Flow Vacuum Generator



### How to order

AMD - S 3 - LG8 - G8  
 ①            ② ③            ④            ⑤

① Series	② Performance	③ Specification	④ Connection plate specification	⑤ Vacuum port specification
AMD	X - High vacuum level	1	LG8 - Straight exhaust, Air supply port: G1/4	G8 - Vacuum port G1
	S - Large vacuum flow	2	Vacuum detecting port: G1/8,	G6 - Vacuum port G3/4
		3	Exhaust detecting port: G1	
		4	LG6 - Side exhaust, Air supply port: G1/4	
			Vacuum detecting port: G1/8,	
			Exhaust port: G3/4	

### Technical parameters

Model	Air supply pressure range bar	Working temperature °C	Rated air supply pressure bar	Max. vacuum level -kPa	Max. vacuum flow NL/min	Air consumption NL/min	Noise level dB(A)	Recommended hose dia. mm	
								(Hose outer dia.) Air supply port	(Wired hose inner dia.) Vacuum port
AMD-X1	4.0~7.0	-10~80	5.0	95	354	130	63~72	≥φ8	≥φ25
AMD-X2	4.0~7.0	-10~80	5.0	95	700	260	63~72	≥φ8	≥φ25
AMD-X3	4.0~7.0	-10~80	5.0	95	980	390	63~72	≥φ10	≥φ45
AMD-X4	4.0~7.0	-10~80	5.0	95	1,380	520	63~72	≥φ10	≥φ45
AMD-S1	4.0~7.0	-10~80	6.0	75	360	135	63~72	≥φ8	≥φ32
AMD-S2	4.0~7.0	-10~80	6.0	75	710	270	63~72	≥φ8	≥φ32
AMD-S3	4.0~7.0	-10~80	6.0	75	1,050	405	63~72	≥φ10	≥φ45
AMD-S4	4.0~7.0	-10~80	6.0	75	1,410	540	63~72	≥φ10	≥φ45

### Vacuum flow(NL/min) at different vacuum levels(-kPa)

Model	Air supply pressure bar	Air consumption NL/min	Max. vacuum level -kPa										
			0	10	20	30	40	50	60	70	80	90	
AMD-X1	5.0	135	354	180	120	78	43.8	34.8	25.8	19.2	10.8	1.8	95
AMD-X2	5.0	270	700	360	240	156	87.6	69.6	51.6	38.4	21.6	3.6	95
AMD-X3	5.0	405	980	540	360	234	131.4	104.4	77.4	57.6	32.4	5.4	95
AMD-X4	5.0	540	1,380	720	480	312	175.2	139.2	103.2	76.8	43.2	7.2	95
AMD-S1	6.0	130	360	210	156	102	54	36	30	21	-	-	75
AMD-S2	6.0	260	710	420	312	204	108	72	60	42	-	-	75
AMD-S3	6.0	390	1,050	630	468	306	162	108	90	66	-	-	75
AMD-S4	6.0	520	1,410	840	624	408	216	144	120	84	-	-	75

# AMD Series

## Large Flow Vacuum Generator



### Evacuation time(s/L) to reach different vacuum levels(-kPa)

Model	Air supply pressure bar	Air consumption NL/min	10	20	30	40	50	60	70	80	90	Max. Vacuum level -kPa
AMD-X1	5.0	135	0.022	0.063	0.12	0.22	0.37	0.57	0.874	1.2	2.2	95
AMD-X2	5.0	270	0.011	0.031	0.06	0.11	0.19	0.29	0.42	0.6	1.1	95
AMD-X3	5.0	405	0.007	0.021	0.04	0.07	0.12	0.19	0.28	0.4	0.73	95
AMD-X4	5.0	540	0.006	0.016	0.03	0.055	0.09	0.14	0.21	0.3	0.55	95
AMD-S1	6.0	130	0.02	0.05	0.1	0.18	0.33	0.53	0.8	-	-	75
AMD-S2	6.0	260	0.01	0.025	0.05	0.09	0.17	0.27	0.4	-	-	75
AMD-S3	6.0	390	0.007	0.017	0.033	0.06	0.11	0.18	0.27	-	-	75
AMD-S4	6.0	520	0.005	0.005	0.025	0.045	0.083	0.13	0.2	-	-	75

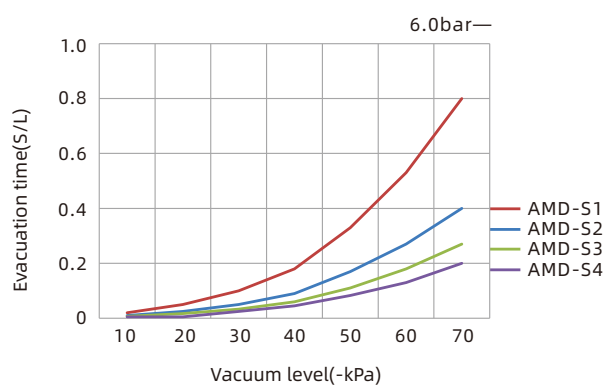
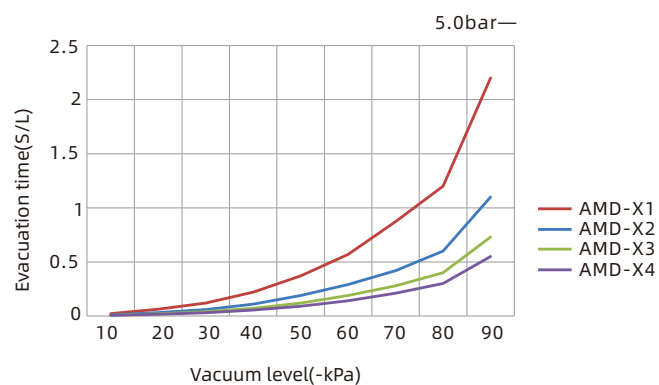
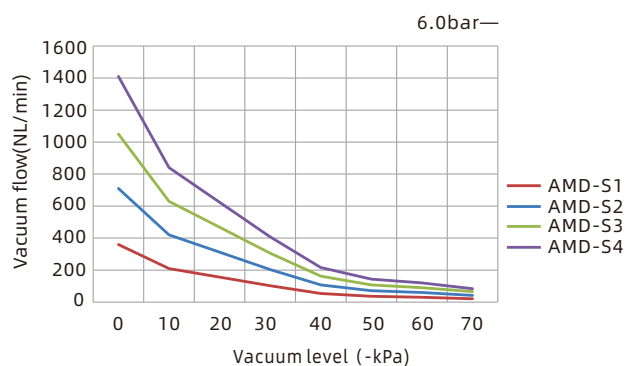
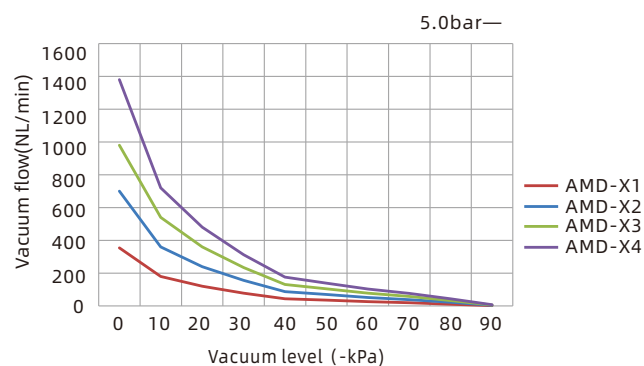

Vacuum Generator

AZK

AZQ

AZX

AZD

AGS

AGP

AGX

AGE

ABM/ABX

ABM/ABX Combined Type

AMC

AM/AL/AH

AM/AL Combined Type

**AMD**

AZW

AZR

ABT

ABP

ABQ

AEVC

AZL

ALH

AZH

AZU

ACV

ASBP

ALS

ACP

ACPF

ACPS

APB

# AMD Series

## Large Flow Vacuum Generator



### Dimensions(mm)

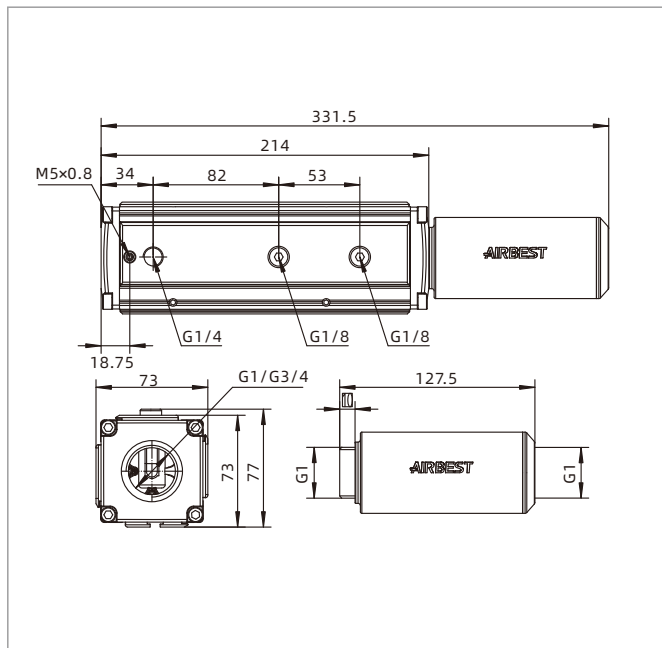

AMD-□-LG8-□ type (Straight exhaust)

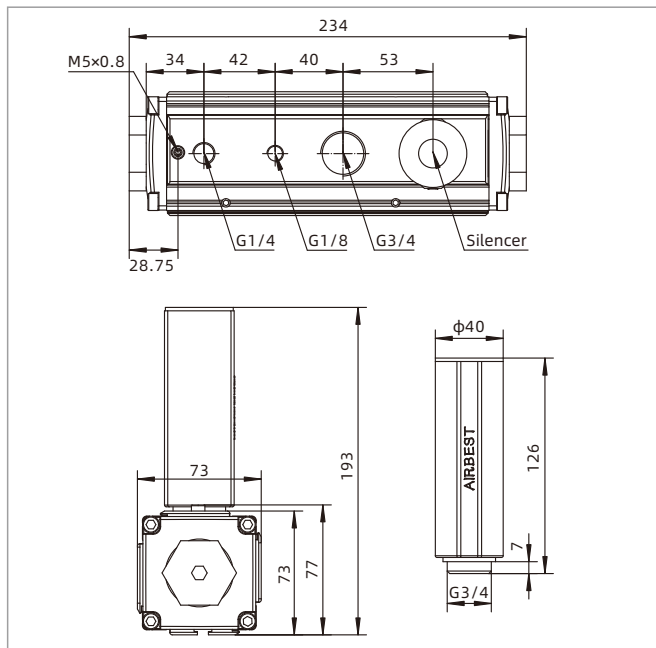

AMD-□-LG6-□ type (Side exhaust)

### Mounting dimensions(mm)

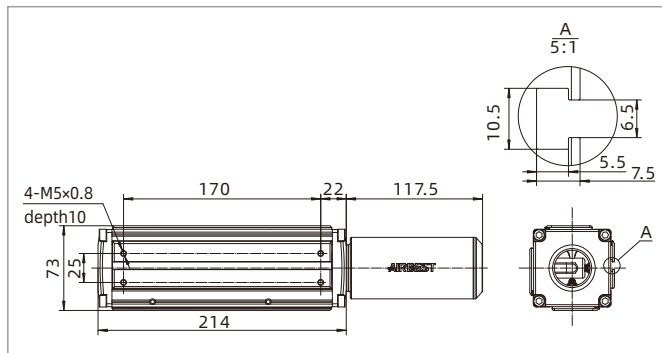

# AZW Series

## Large Flow Integrated Vacuum Generator



BIO-PHARMACEUTICAL



FOOD INDUSTRY



### Features

- ◇ Built-in high performance vacuum cartridge
- ◇ External silencer
- ◇ Centralized air supply, solenoid valves of each station controll separately
- ◇ Multi-station, large flow, integrated design

### Advantages

- ◇ Easy installation, easy maintenance, it can be replaced by users themselves
- ◇ Reduce product noise most
- ◇ Customers can open or close according to the actual application conditions to save air source
- ◇ High vacuum level, large flow, it can reach high vacuum level in a short time

### Applications

- ◇ Suitable for multi-station vacuum grasping applications
- ◇ Suitable for the occasions with high demand on the evacuation time
- ◇ Suitable for fast evacuation occasions in medical and food industry

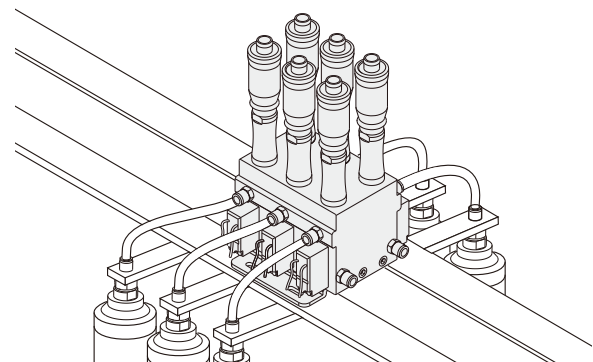

### Structure

- ◇ (1) Vacuum port
- ◇ (2) Air supply valve
- ◇ (3) Mounting bracket
- ◇ (4) Silencer
- ◇ (5) Vacuum cartridge
- ◇ (6) Air supply port

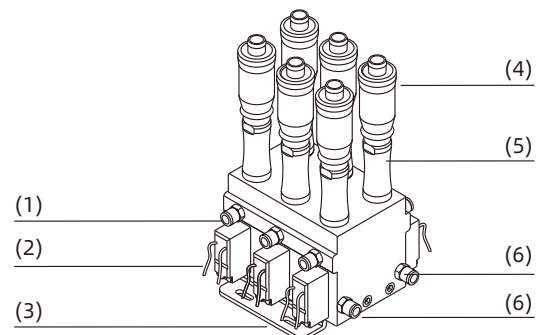

Vacuum Generator

AZK

AZQ

AZX

AZD

AGS

AGP

AGX

AGE

ABM/ABX

ABM/ABX  
Combined Type

AMC

AM/AL/AH

AM/AL  
Combined Type

AMD

**AZW**

AZR

ABT

ABP

ABQ

AEVC

AZL

ALH

AZH

AZU

ACV

ASBP

ALS

ACP

ACPF

ACPS

APB

### How to order

## AZW - 06V

①                      ②

① Series	② Vacuum stack quantity
AZW	03V - 3 stacks 04V - 3 stacks 06V - 6 stacks

### Technical parameters

Model	Air supply pressure range bar	Rated air supply pressure bar	Max.vacuum level -kPa	Max. vacuum flow NL/min	Air consumption NL/min	Noise level dB(A)
AZW	4.0~7.0	6.0	95	140	135	74

Model	Solenoid valve rated working voltage V	Solenoid valve status	Solenoid valve rated power W	Working temperature °C	Weight kg		Recommended hose dia.mm	
					03V	06V	Air supply port P	Vacuum port V
AZW	DC24	Normally closed(NC)	5.4	0~60	1.2	2.3	φ10	φ10

### Vacuum flow(NL/min) at different vacuum levels(-kPa)

Model	Air supply pressure bar	Air consumption NL/min	Vacuum level (-kPa)											Max. vacuum level -kPa
			0	10	20	30	40	50	60	70	80	90		
AZW	6.0	135	140	117	106	76	54	36	26	18	11.5	5.2	95	

### Evacuation time(s/L) to reach different vacuum levels(-kPa)

Model	Air supply pressure bar	Air consumption NL/min	Vacuum level (-kPa)										Max. vacuum level -kPa
			1	20	30	40	50	60	70	80	90		
AZW	6.0	135	0.01	0.02	0.08	0.23	0.43	0.71	1.04	1.61	3.72	95	

◇ Note: The above data is the data of one stack, the actual air consumption and max. vacuum flow need to be multiplied by the number of stack of the vacuum generator

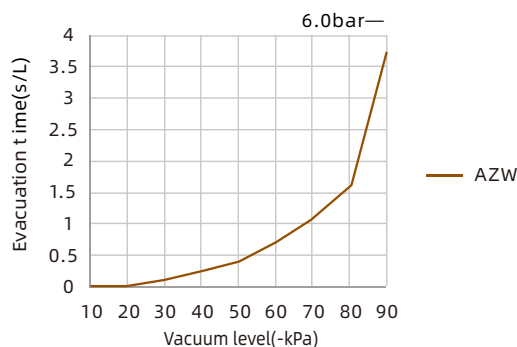
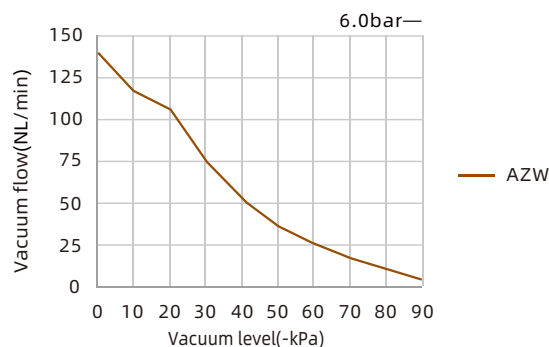

# AZW Series

## Large Flow Integrated Vacuum Generator



### Dimensions(mm)

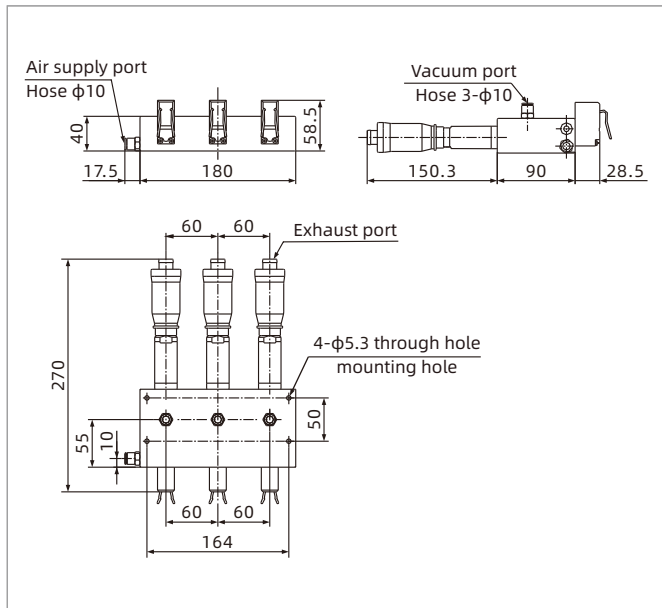

AZW-03V

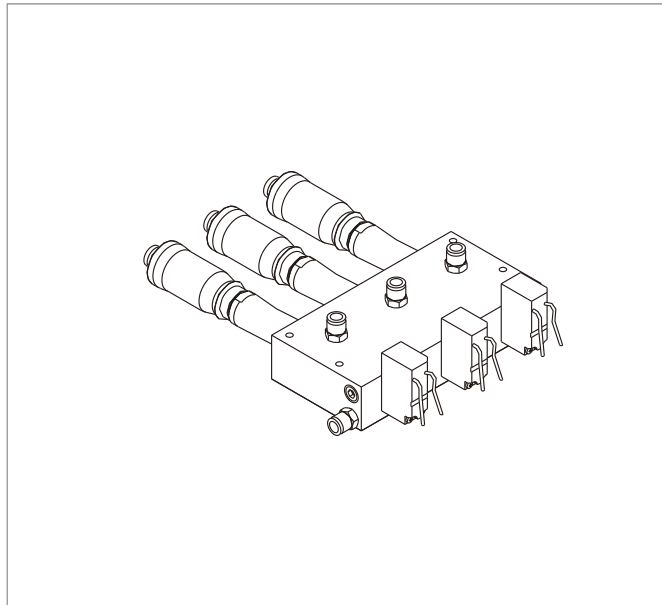

AZW-03V Schematic diagram

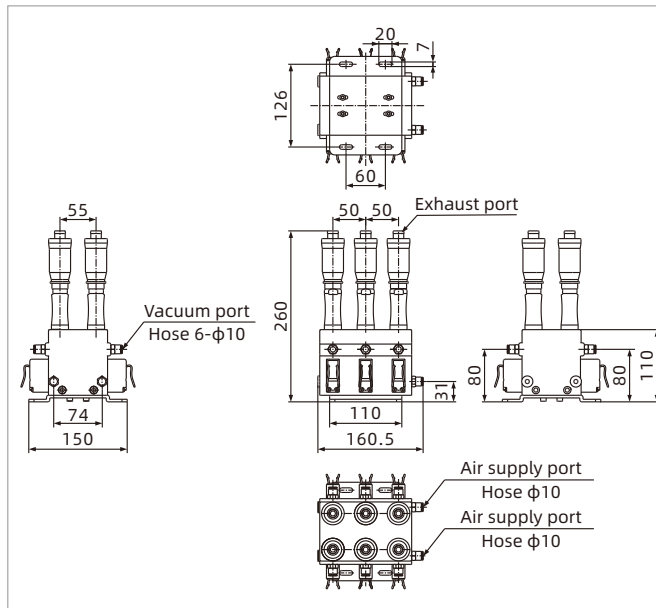

AZW-06V

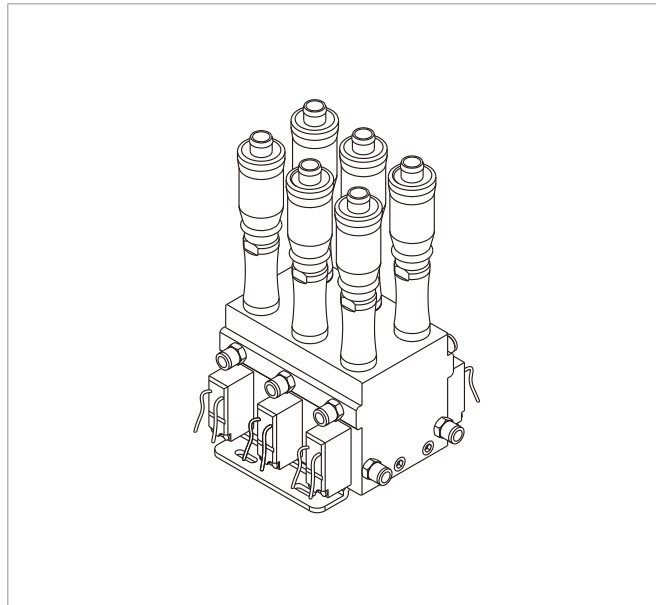

AZW-06V Schematic diagram

Vacuum Generator	
AZK	
AZQ	
AZX	
AZD	
AGS	
AGP	
AGX	
AGE	
ABM/ABX	
ABM/ABX Combined Type	
AMC	
AM/AL/AH	
AM/AL Combined Type	
<b>AZW</b>	
AZR	
ABT	
ABP	
ABQ	
AEVC	
AZL	
ALH	
AZH	
AZU	
ACV	
ASBP	
ALS	
ACP	
ACPF	
ACPS	
APB	

# AZR Series

## Mini Vacuum Generator

**AIRBEST**



ELECTRONICS



PLASTIC



### Features

- ◇ Small size, light weight
- ◇ High vacuum level type and large vacuum flow type are optional
- ◇ The generator has vacuum breaking function itself
- ◇ Separate vacuum filter and mounting bracket are optional

### Advantages

- ◇ For the occasions with limited installation space and weight
- ◇ It can meet different requirements of vacuum flow in different working conditions
- ◇ There is no need for external control device, can quickly release the product
- ◇ Customers can choose freely according to the actual working conditions



### Applications

- ◇ Suitable for handling electronic components and other small workpieces
- ◇ Suitable for working occasions where quick picking and quick release are required

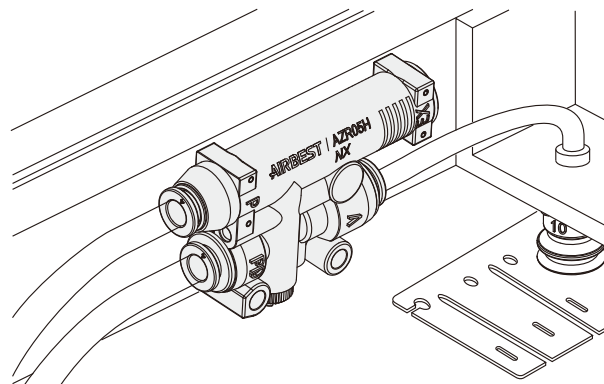

### Structure

- ◇ (1) Release port
- ◇ (2) Vacuum release regulating valve
- ◇ (3) Lock nut
- ◇ (4) Vacuum detecting port
- ◇ (5) Vacuum port
- ◇ (6) Vacuum filter
- ◇ (7) Air supply port
- ◇ (8) Exhaust port

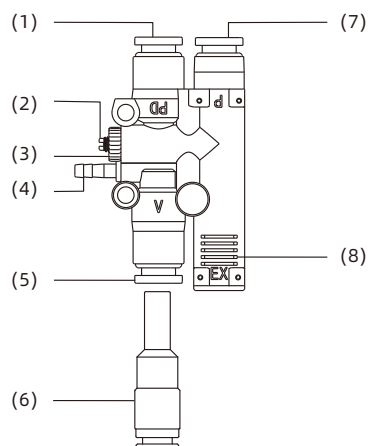

# AZR Series

## Mini Vacuum Generator

### How to order

**AZR 07 H - J - V - F**  
 ①      ②      ③      ④      ⑤      ⑥

① Series	② Nozzle Diameter	③ Specification	④ Exhaust way	⑤ Special specification	⑥ Vacuum filter
AZR	05 - $\phi$ 0.5mm 07 - $\phi$ 0.7mm	H - High vacuum level type L - Large vacuum flow type	Nil - Direct exhaust J - Centralized exhaust	Nil - Standard type V - Vacuum detecting port	Nil - Standard type F - With vacuum filter

### Selection

Model/ Nozzle Diameter	05		07	
AZR□□	AZR05H	AZR05L	AZR07H	AZR07L
AZR□□-J	AZR05H-J	AZR05L-J	AZR07H-J	AZR07L-J
AZR□□-J-F	AZR05H-J-F	AZR05L-J-F	AZR07H-J-F	AZR07L-J-F
AZR□□-J-V	AZR05H-J-V	AZR05L-J-V	AZR07H-J-V	AZR07L-J-V
AZR□□-J-V-F	AZR05H-J-V-F	AZR05L-J-V-F	AZR07H-J-V-F	AZR07L-J-V-F
AZR□□-V	AZR05H-V	AZR05L-V	AZR07H-V	AZR07L-V
AZR□□-V-F	AZR05H-V-F	AZR05L-V-F	AZR07H-V-F	AZR07L-V-F
AZR□□-F	AZR05H-F	AZR05L-F	AZR07H-F	AZR07L-F

### Technical parameters

Model	Rated air supply pressure bar	Max. vacuum level -kPa	Max. vacuum flow NL/min	Max. break flow rate NL/min	Air consumption NL/min	Noise level dB(A)	Weight g	Air supply port P	Recommended hose dia. mm Vacuum port V
AZR05H	5.0	88	7.0	40	11	75	19	$\phi$ 4	$\phi$ 4
AZR07H	5.0	88	12.5	40	22	75	20	$\phi$ 6	$\phi$ 6
AZR05L	5.0	58	12.0	40	11	70	19	$\phi$ 4	$\phi$ 4
AZR07L	5.0	58	20.0	40	22	70	20	$\phi$ 6	$\phi$ 6

◇ Note: Max. air supply pressure is 6.0 bar.

### Vacuum flow(NL/min) at different vacuum levels(-kPa)

Model	Air supply pressure bar	Air consumption NL/min	0	10	20	30	40	50	60	70	80	Max. vacuum level -kPa
AZR05H	5.0	11	8.0	7.3	6.3	5.2	4.2	3.4	2.2	1.4	1.0	88
AZR07H	5.0	22	12.5	11.5	9.7	7.4	6.5	5.2	4.1	3.0	1.7	88
AZR05L	5.0	11	12.5	10.5	8.7	6.9	5.0	2.9	1.0	-	-	58
AZR07L	5.0	22	22.0	19.1	14.5	9.4	7.2	4.3	1.0	-	-	58

# AZR Series

## Mini Vacuum Generator

### Vacuum flow(NL/min) at different vacuum levels(-kPa)

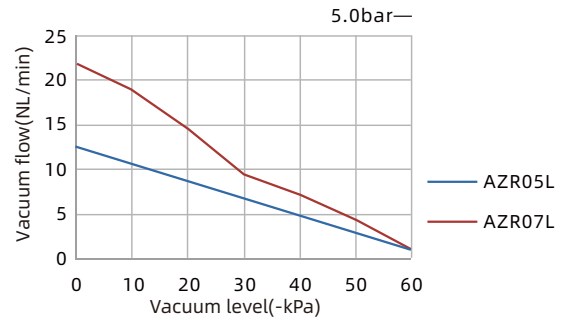
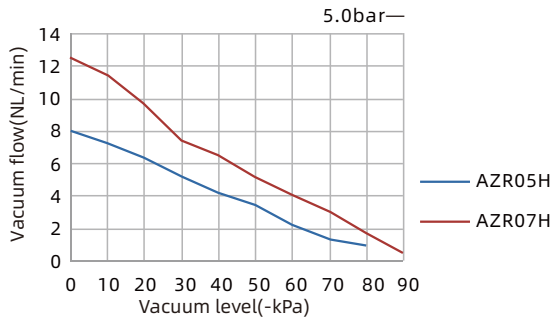

### Evacuation time(s/L) to reach different vacuum levels(-kPa)

Model	Air supply pressure bar	Air consumption NL/min	10	20	30	40	50	60	70	80	Max. vacuum level -kPa
AZR05H	5.0	11	0.42	0.83	1.30	1.92	3.2	4.5	6.3	10.5	88
AZR07H	5.0	22	0.34	0.75	1.22	1.87	2.7	3.8	5.7	9.9	88
AZR05L	5.0	11	0.32	0.64	1.06	1.73	2.9	8.2	-	-	58
AZR07L	5.0	22	0.23	0.53	0.93	1.53	2.8	7.8	-	-	58

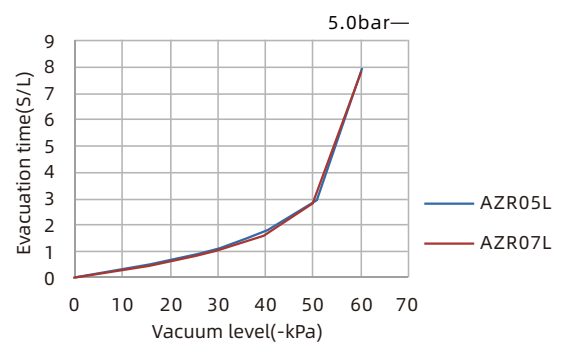
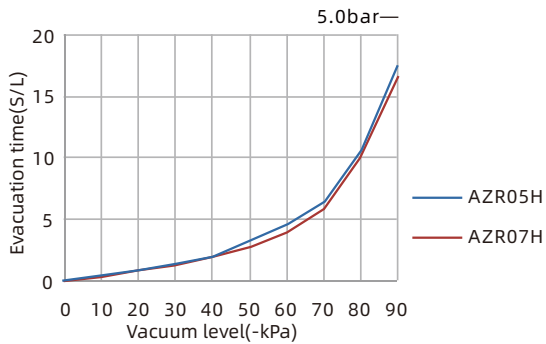

### Air circuit schematic diagram

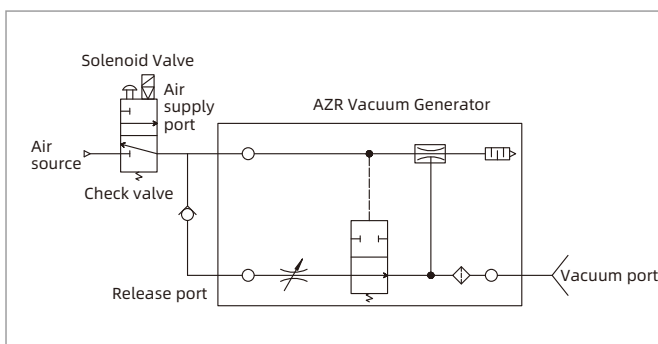

#### Vacuum release principle and attentions:

- ◇ 1. Close solenoid valve and stop air supply, open the release valve. The residual positive pressure air in the air circuit between check valve and release port flows into the vacuum circuit to release vacuum
- ◇ 2. Change the tube length between the check valve and release port to adjust the residual positive pressure air volume. In this way, the vacuum releasing time can be adjusted
- ◇ 3. The vacuum releasing flow of this way is small

# AZR Series

## Mini Vacuum Generator

### Air circuit schematic diagram

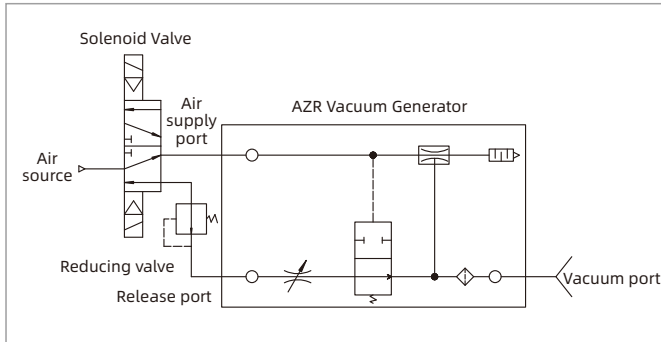

Vacuum release principle and attentions:

- ◇ 1. Close solenoid valve and stop air supply, open the release valve, and the positive pressure air flows directly into the vacuum circuit to release the vacuum
- ◇ 2. Can adjust the vacuum releasing time through controlling the air supply time of solenoid valve
- ◇ 3. Adjust the air releasing pressure through the reducing valve to avoid excessive pressure blowing away the workpiece
- ◇ 4. The air releasing pressure must be lower than air supply pressure of vacuum generator
- ◇ 5. The releasing flow and pressure can be adjusted freely as required

### Dimensions(mm)

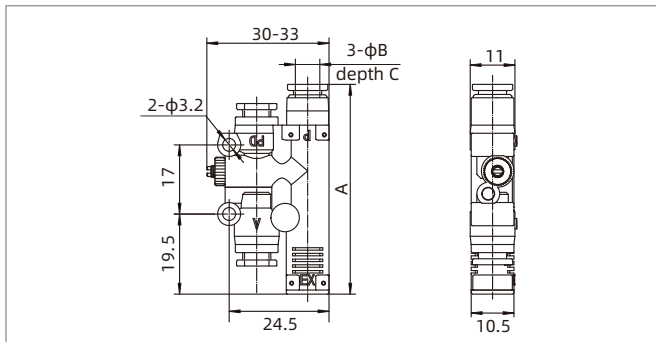

AZR□□

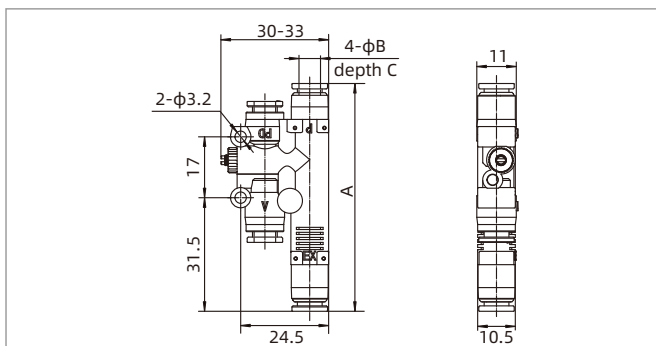

AZR□□-J

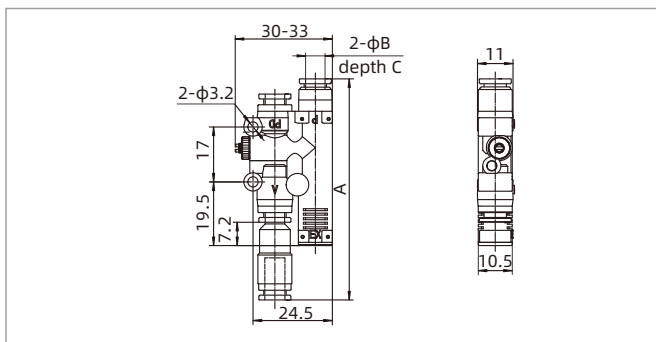

AZR□□-F

Model/Size	A	B	C
AZR05H	49.5	4	10
AZR05L	49.5	4	10
AZR07H	51.5	6	12.5
AZR07L	51.5	6	12.5

◇ Note: "C" is insert depth

Model/Size	A	B	C
AZR05H-J	61.5	4	10
AZR05L-J	61.5	4	10
AZR07H-J	63.5	6	12.5
AZR07L-J	63.5	6	12.5

◇ Note: "C" is insert depth

Model/Size	A	B	C
AZR05H-F	65.5	4	10
AZR05L-F	65.5	4	10
AZR07H-F	68.8	6	12.5
AZR07L-F	68.8	6	12.5

◇ Note: "C" is insert depth

# AZR Series

## Mini Vacuum Generator

### Dimensions(mm)

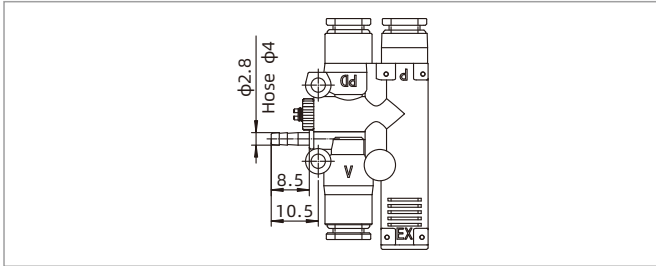

AZR□□-V

### Vacuum release function

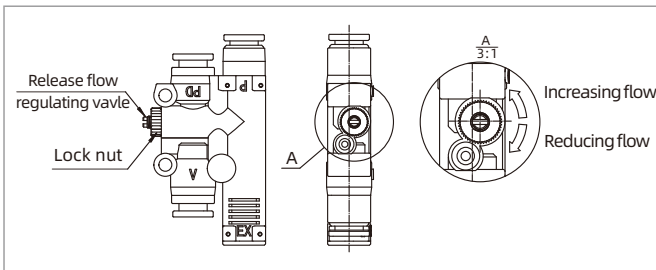

Vacuum releasing flow regulation:

- ◇ 1. Rotating clockwise the releasing flow regulating valve to reduce the releasing flow. Rotating counterclockwise the releasing flow regulating valve to increase the releasing flow
- ◇ 2. When regulation is finished, tighten the lock nut clockwise to fix the position of the regulating valve
- ◇ 3. The regulating valve has limited positions. When it can not be turned clockwise or counterclockwise, it means that the limit position has been reached

### Repair kits dimensions(mm)

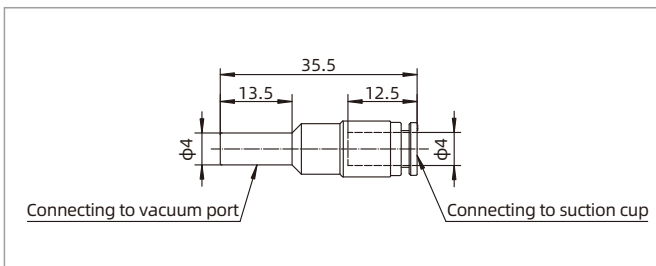

ZFD04 Vacuum filter

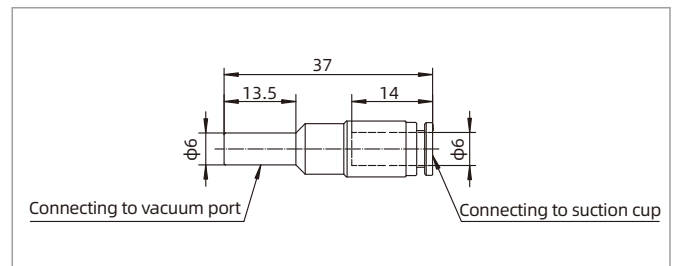

ZFD06 Vacuum filter

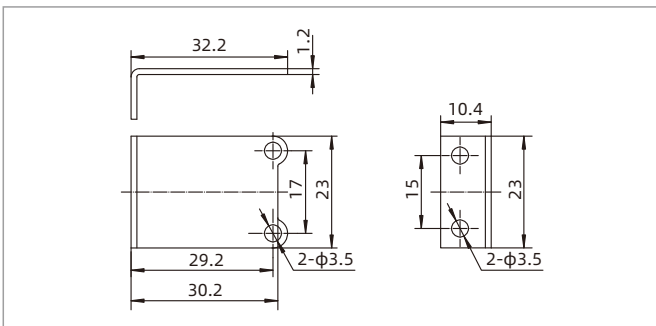

AZR-B Mounting bracket

Item	Model	Applicable vacuum generator
Vacuum filter	ZFD04	AZR05H、AZR05L
Vacuum filter	ZFD06	AZR07H、AZR07L
Mounting bracket	AZR-B	AZR05H、AZR05L、AZR07H、AZR07L

# ABT Series

## Mini Vacuum Generator

**AIRBEST**



UNIVERSAL



### Features

- ◇ Linear installation
- ◇ Long and thin plastic housing, compact size
- ◇ Quick plug connector for direct connection
- ◇ Optimal lateral direct exhaust design

### Advantages

- ◇ Can be connected to the hose directly
- ◇ Suitable for installation in narrow spaces
- ◇ Convenient connection, no additional installation accessories are required
- ◇ Minimize product noise



### Applications

- ◇ The linear vacuum generator can be connected to the PU hose directly
- ◇ Suitable for the handling systems with limited space

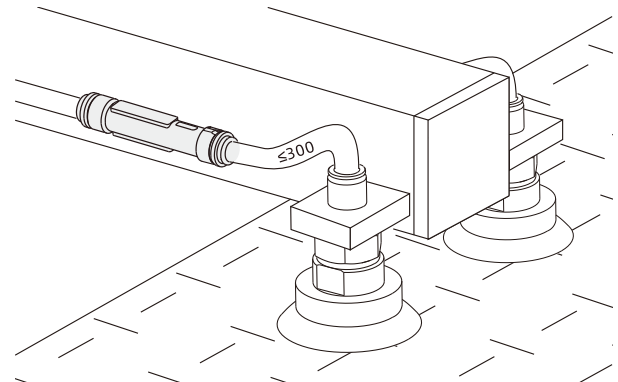

### Structure

- ◇ (1) Air supply port
- ◇ (2) Vacuum port
- ◇ (3) Exhaust port

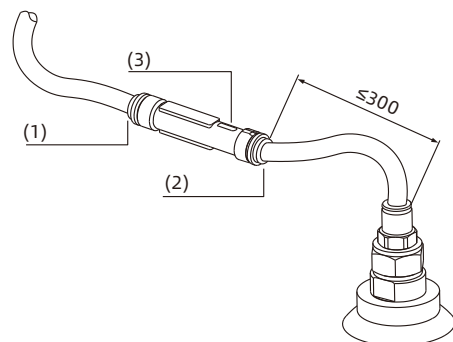

Vacuum Generator

AZK

AZQ

AZX

AZD

AGS

AGP

AGX

AGE

ABM/ABX

ABM/ABX  
Combined Type

AMC

AM/AL/AH

AM/AL  
Combined Type

AMD

AZW

AZR

**ABT**

ABP

ABQ

AEVC

AZL

ALH

AZH

AZU

ACV

ASBP

ALS

ACP

ACPF

ACPS

APB

# ABT Series

## Mini Vacuum Generator

### How to order

## ABT - T05

①      ②

① Series	② Specification
ABT	S02 X10 T05 P12 X2.5 D16 S08

### Technical parameters

Model	Air supply pressure range bar	Rated air supply pressure bar	Max. vacuum level -kPa	Max. vacuum flow NL/min	Air consumption NL/min	Noise level dB(A)	Working temperature °C	Weight g	Recommended hose dia.(mm)	
									Air supply port	Vacuum port
ABT-S02	4.0~7.0	6.0	75	16.8	8	70	0~60	15	φ6	φ6
ABT-T05	4.0~7.0	5.0	81	18	18.5	70	0~60	15	φ6	φ6
ABT-X2.5	4.0~7.0	5.0	90	15.6	9.5	70	0~60	15	φ6	φ6
ABT-S08	4.0~7.0	6.0	75	46	27	73	0~60	29	φ8	φ8
ABT-X10	4.0~7.0	5.0	92	42	30	73	0~60	29	φ8	φ8
ABT-P12	2.0~7.0	3.14	90	42	29	73	0~60	29	φ8	φ8
ABT-D16	4.0~7.0	6.0	72	40	46	77	0~60	29	φ8	φ8

### Vacuum flow(NL/min) at different vacuum levels(-kPa)

Model	Air supply pressure bar	Air consumption NL/min	Vacuum level (-kPa)									Max. vacuum level -kPa
			0	10	20	30	40	50	60	70	80	
ABT-S02	6.0	8	16.8	12.2	6.3	4.6	3.9	3.0	2.0	-	-	75
ABT-T05	5.0	18.5	18	16.2	13.3	9.9	8.2	5.6	4.2	3.1	1.3	81
ABT-X2.5	5.0	9.5	15.6	11.6	6.6	4	3.3	2.6	1.7	-	-	90
ABT-S08	6.0	27	46	42	32.6	22.6	12	9.8	8.3	5.9	-	75
ABT-X10	5.0	30	42	40	30.6	22.2	13.5	8.9	6.6	4.5	2	92
ABT-P12	3.14	29	42	36	25.6	14.9	10.4	8.9	6.6	4.2	1.9	90
ABT-D16	6.0	46	40	38	30.5	26.7	22	17	12	3.5	-	72

### Evacuation time(s/L) to reach different vacuum levels(-kPa)

Model	Air supply pressure bar	Air consumption NL/min	Vacuum level (-kPa)									Max. vacuum level -kPa
			10	20	30	40	50	60	70	80		
ABT-S02	6.0	8	0.3	1.1	2.4	4.1	6.2	9	14.3	-	75	
ABT-T05	5.0	18.5	0.18	0.52	1.11	1.98	3.35	5.45	8.5	14.6	81	
ABT-X2.5	5.0	9.5	0.3	0.9	2.4	4.3	6.7	9.5	14.1	22.03	90	
ABT-S08	6.0	27	0.07	0.2	0.39	0.74	1.35	2.14	3.35	-	75	
ABT-X10	5.0	30	0.05	0.23	0.48	0.95	1.68	2.71	4.18	6.86	92	
ABT-P12	3.14	29	0.12	0.29	0.59	1.07	1.86	2.66	4.33	6.72	90	
ABT-D16	6.0	46	0.04	0.18	0.39	0.63	0.95	1.47	3.1	-	72	

# ABT Series

## Mini Vacuum Generator



### Technical parameters

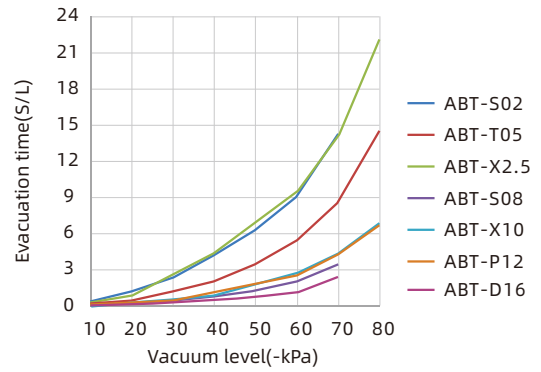
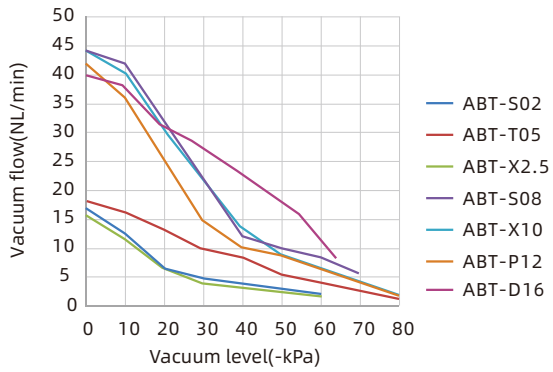

### Dimensions(mm)

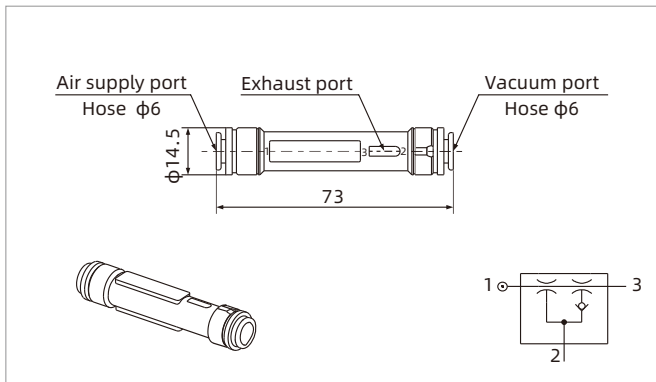

ABT-S02/T05/X2.5

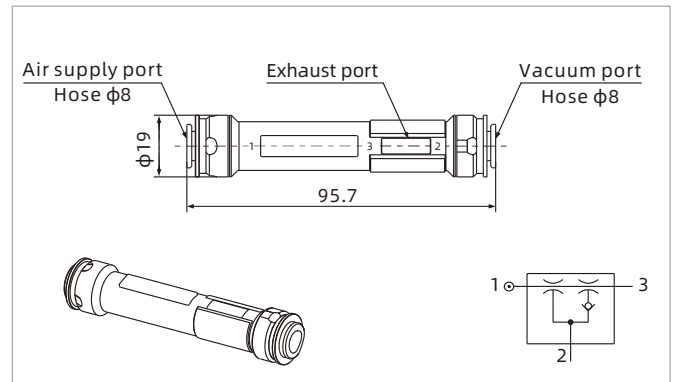

ABT-S08/X10/P12/D16

Vacuum Generator

AZK

AZQ

AZX

AZD

AGS

AGP

AGX

AGE

ABM/ABX

ABM/ABX  
Combined Type

AMC

AM/AL/AH

AM/AL  
Combined Type

AMD

AZW

AZR

**ABT**

ABP

ABQ

AEVC

AZL

ALH

AZH

AZU

ACV

ASBP

ALS

ACP

ACPF

ACPS

APB

# ABP Series

## Vacuum Generator with Fast Blow-off

**AIRBEST**



UNIVERSAL

RoHS

### Features

- ◇ Axial connection
- ◇ Plastic housing, compact size, light weight
- ◇ Connect plug-in fitting directly
- ◇ Optimal direct lateral exhaust design
- ◇ Built-in fast breaking device, no need of external drive

### Advantages

- ◇ Connect hose directly
- ◇ Suitable for installing in narrow space
- ◇ Easy to mount, there is no need to add extra mounting accessories
- ◇ Reduce product noise most
- ◇ Release product fast



### Applications

- ◇ The linear vacuum generator can be connected with the PU hose directly
- ◇ Suitable for the handling systems with limited space
- ◇ Suitable for occasions where there is no need of external drive and can automatically release workpiece fast
- ◇ Suitable for occasions where need to grip and release workpieces fastly, and there is requirement for light weight of whole equipment, etc.

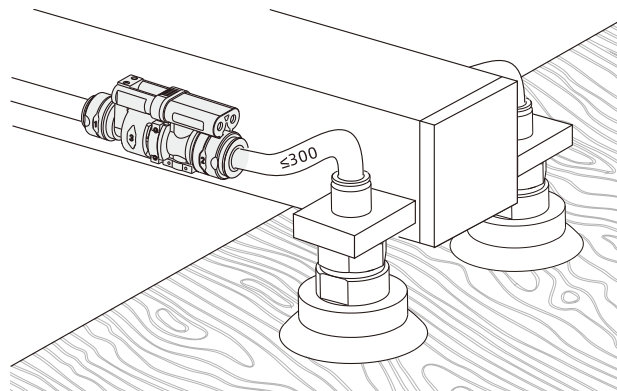

### Structure

- ◇ (1) Air supply port
- ◇ (2) Vacuum port
- ◇ (3) Exhaust port

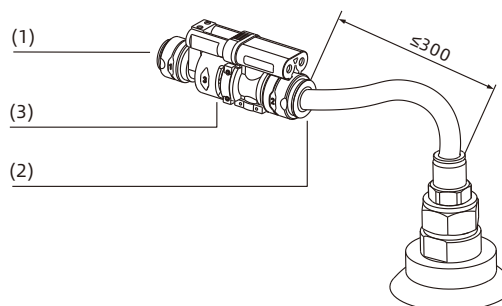

# ABP Series

## Vacuum Generator with Fast Blow-off



### How to order

ABP - 10

① ②

Series	Specification
ABP	10

### Technical parameters

Model	Air supply pressure range bar	Rated air supply pressure bar	Max. vacuum level -kPa	Max. vacuum flow NL/min	Max. consumption NL/min	Air consumption NL/min	Noise level dB(A)	Working temperature °C	Weight g	Recommended hose dia.(mm)	
										Air supply port P	Vacuum port V
ABP-10	4.0~7.0	5.0	81	38	38	38	70	0~60	34	φ8	φ10

### Vacuum flow(NL/min) at different vacuum levels(-kPa)

Model	Air supply pressure bar	Air consumption NL/min	Vacuum level (-kPa)										Max. vacuum level -kPa
			0	10	20	30	40	50	60	70	80		
ABP-10	5.0	38	38.0	32.4	26.3	18.9	11.5	7.1	5.0	3.2	0.8	81	

### Evacuation time(s/L) to reach different vacuum levels(-kPa)

Model	Air supply pressure bar	Air consumption NL/min	Vacuum level (-kPa)										Max. vacuum level -kPa
			10	20	30	40	50	60	70	80			
ABP-10	5.0	38	0.12	0.32	0.61	1.08	1.76	2.73	4.29	7.58	81		

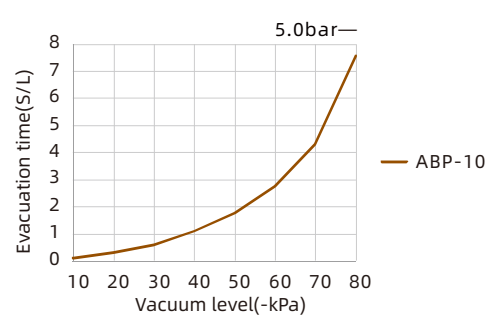
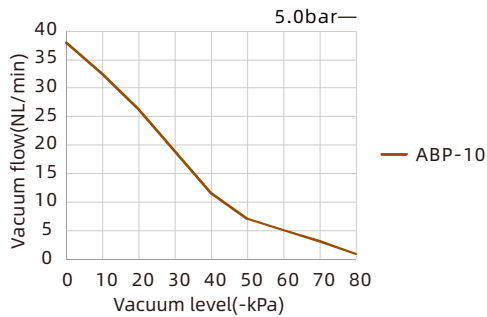

### Dimensions(mm)

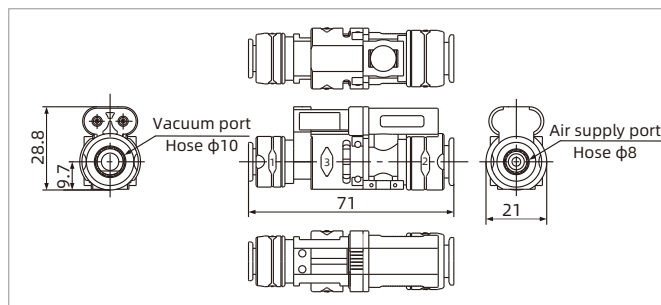

ABP-10

### ABP-10 Air circuit schematic diagram

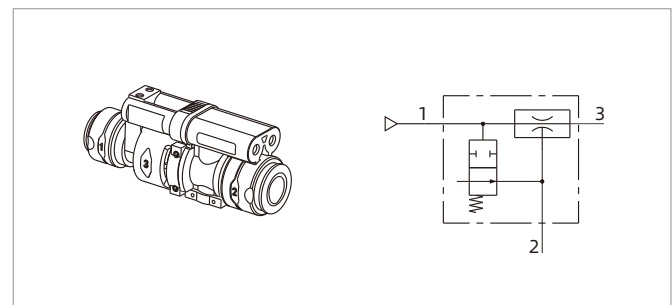

ABP-10

Note: 1. Air supply port, 2. Vacuum port, 3. Exhaust port

Vacuum Generator

AZK

AZQ

AZX

AZD

AGS

AGP

AGX

AGE

ABM/ABX

ABM/ABX Combined Type

AMC

AM/AL/AH

AM/AL Combined Type

AMD

AZW

AZR

ABT

**ABP**

ABQ

AEVC

AZL

ALH

AZH

AZU

ACV

ASBP

ALS

ACP

ACPF

ACPS

APB

# ABQ Series

## Vacuum Generator with Fast Blow-off

**AIRBEST**



UNIVERSAL

RoHS

### Features

- ◇ Plastic housing, compact size and light weight
- ◇ Connect plug-in fitting directly
- ◇ Optimal direct lateral exhaust design
- ◇ Built-in fast blow-off device

### Advantages

- ◇ Suitable for installing in narrow space
- ◇ Easy installation, no need extra mounting accessory
- ◇ Minimize product noise
- ◇ Safe and reliable with fast blow-off system



### Applications

- ◇ Suitable for handling system with limited space
- ◇ Suitable for occasions where require safe and quick release of the workpieces
- ◇ Suitable for occasions where need to grip and release workpieces fastly, and there is requirement for light weight of whole equipment, etc.

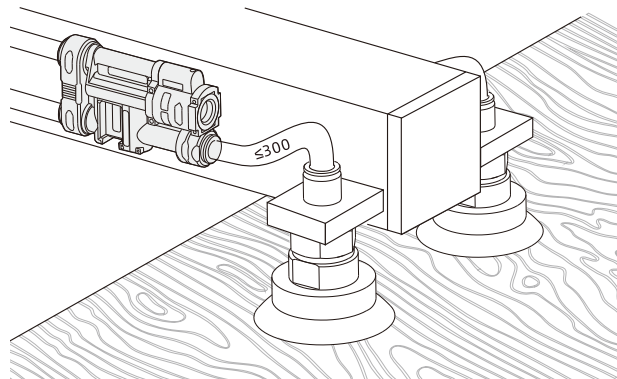

### Structure

- ◇ (11) Air supply port
- ◇ (12) Vacuum release port
- ◇ (2) Vacuum port
- ◇ (3) Exhaust port

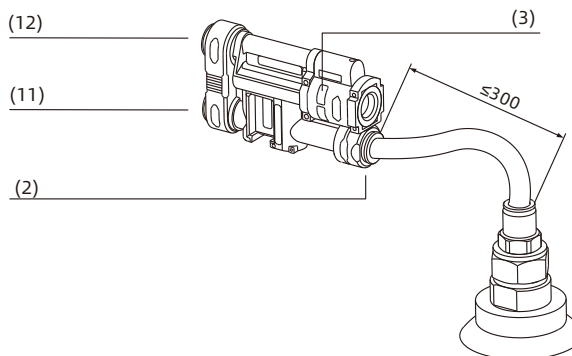

# ABQ Series

## Vacuum Generator with Fast Blow-off



### How to order

ABQ - 08

① ②

Series	Specification
ABQ	08

### Technical parameters

Model	Air supply pressure range bar	Rated air supply pressure bar	Max. vacuum level -kPa	Max. vacuum flow NL/min	Air consumption NL/min	Noise level dB(A)	Working temperature °C	Weight g	Recommended hose dia.(mm)	
									Air supply port	Vacuum port
ABQ-08	4.0~7.0	5.0	81	38	38	70	0~60	55	φ8	φ8

### Vacuum flow(NL/min) at different vacuum levels(-kPa)

Model	Air supply pressure range bar	Air consumption NL/min	0	10	20	30	40	50	60	70	80	Max. vacuum level -kPa
			ABQ-08	5.0	38	38.0	32.4	26.3	18.9	11.5	7.1	

### Evacuation time(s/L) to reach different vacuum levels(-kPa)

Model	Air supply pressure range bar	Air consumption NL/min	10	20	30	40	50	60	70	80	Max. vacuum level -kPa
			ABQ-08	5.0	38	0.12	0.32	0.61	1.08	1.76	

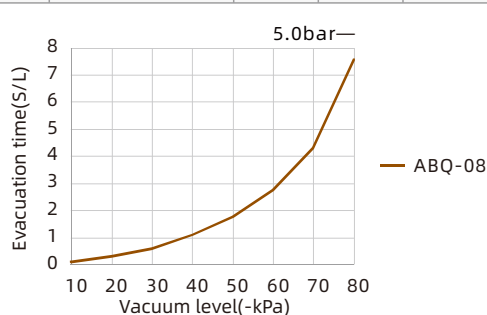
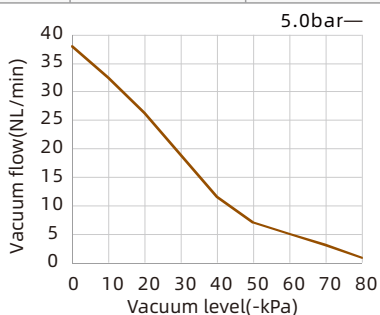

### Dimensions(mm)

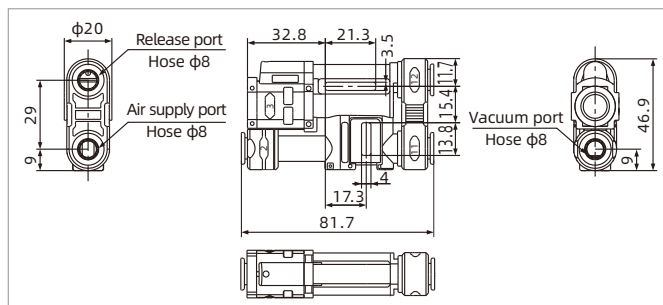

ABQ-08

### ABQ-08 Air circuit schematic diagram

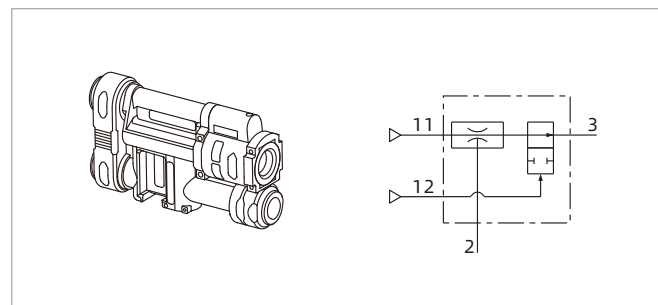

ABQ-08 Note: 11. Air supply port, 12. Release port, 3. Exhaust port, 2: Vacuum port

Vacuum Generator

AZK

AZQ

AZX

AZD

AGS

AGP

AGX

AGE

ABM/ABX

ABM/ABX Combined Type

AMC

AM/AL/AH

AM/AL Combined Type

AMD

AZW

AZR

ABT

ABP

**ABQ**

AEVC

AZL

ALH

AZH

AZU

ACV

ASBP

ALS

ACP

ACPF

ACPS

APB

# AEVC Series

## Vacuum Generator with Fast Blow-off



METAL SHEET



PACKAGING



AUTOMOTIVE



### Features

- ◇ Fast suction and blow-off
- ◇ Main body is made of plastic
- ◇ Suitable mounting bracket
- ◇ With built-in silencer

### Advantages

- ◇ Short action cycle
- ◇ Small size, light weight, especially suitable for high speed working
- ◇ Could be fixed with suction cup and connector directly
- ◇ Reduce noise greatly



### Applications

- ◇ Suitable for occasions where need blow-off function and short working cycle, such as metal sheet processing, automotive industry, packaging machine and industrial robot

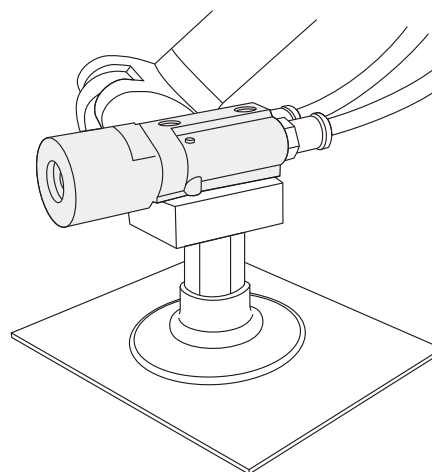

### Structure

- ◇ (1) Air supply port
- ◇ (2) Vacuum port
- ◇ (3) Release port
- ◇ (4) Silencer
- ◇ (5) Mounting hole

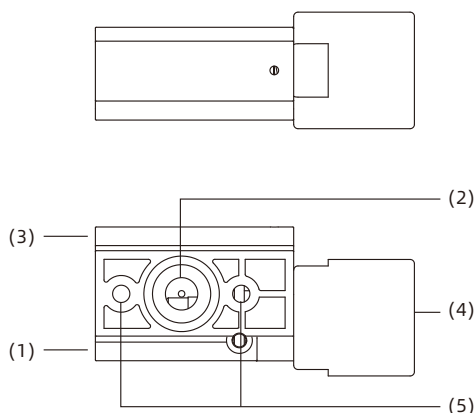

### How to order

**AEVC 10 - S - G2F**  
 ①            ②            ③            ④

Series	Nozzle diameter	Mounting type	Mounting thread
AEVC	10 - $\phi$ 1.0mm	Nil - Without mounting block S - Vertical mounting block L - Lateral mounting block B - Oval vertical mounting block	Nil - Without thread G1F - G1/8 female thread G2F - G1/4 female thread

### Selection

Model/Mounting type Nil - Without mounting block	S - Vertical mounting block	L - Lateral mounting block	B - Oval vertical mounting block
AEVC10	AEVC10-S-G2F	AEVC10-L-G2F	AEVC10-B-G1F    AEVC10-B-G2F

### Technical parameters

Model	Rated air supply pressure bar	Max. vacuum level -kPa	Max.vacuum flow NL/min	Air consumption NL/min	Noise level dB(A)	Weight g
AEVC10	4.5	85	35	48.5	73.5	64

### Vacuum flow(NL/min) at different vacuum levels(-kPa)

Model	Air supply pressure bar	Air consumption NL/min	Vacuum level (-kPa)										Max. vacuum level -kPa
			0	10	20	30	40	50	60	70	80		
AEVC10	4.5	48.5	35.0	32.0	30.0	24.0	18.0	10.0	6.5	5.5	3.3	85	

### Evacuation time(s/L) to reach different vacuum levels(-kPa)

Model	Air supply pressure bar	Air consumption NL/min	Vacuum level (-kPa)										Max. vacuum level -kPa
			10	20	30	40	50	60	70	80			
AEVC10	4.5	48.5	0.14	0.30	0.54	0.81	1.19	1.70	2.42	4.27	85		

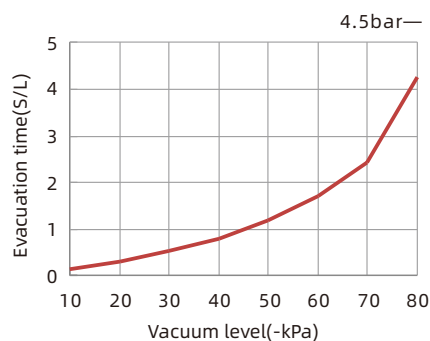
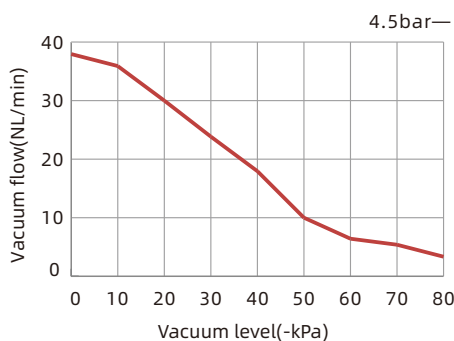

# AEVC Series

## Vacuum Generator with Fast Blow-off



### Installation instruction

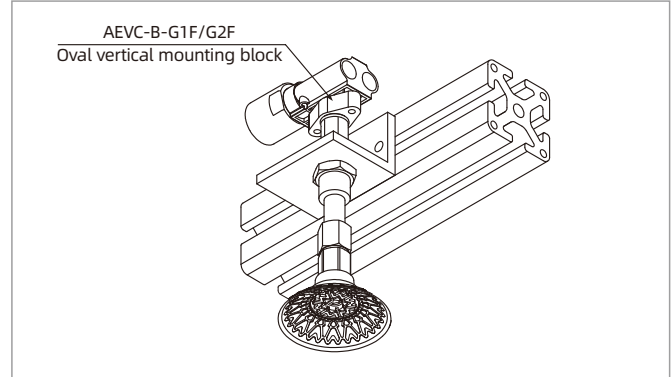
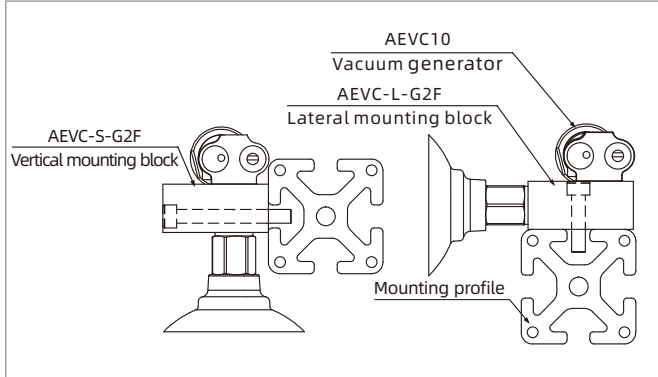

### Dimensions(mm)

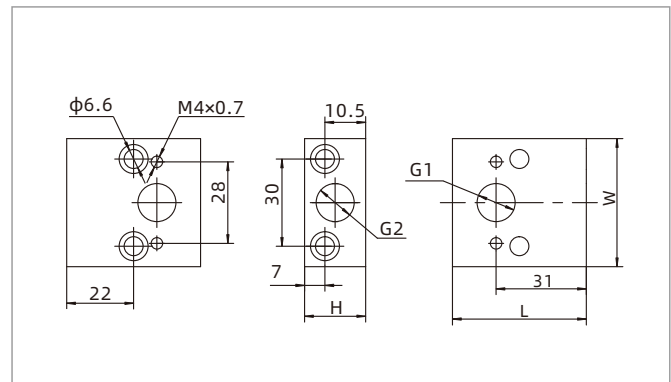
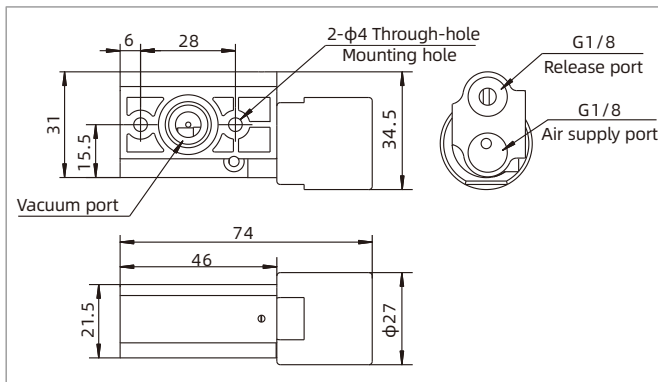

AEVC10

AEVC-S-G2F AEVC-L-G2F

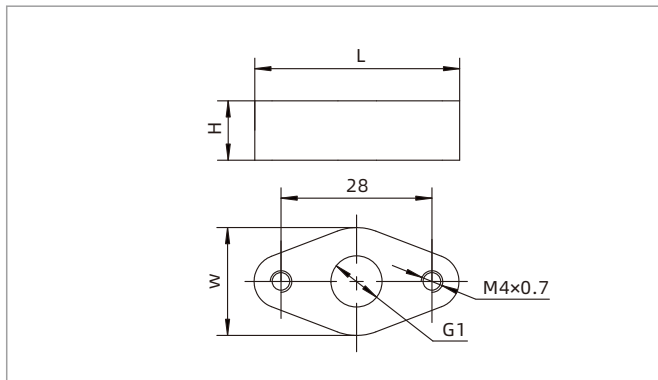

AEVC-B-G1F AEVC-B-G2F

Model/Size	L	W	H	G1	G2
AEVC-L-G2F	46	44	21	G1/4	-
AEVC-S-G2F	46	44	21	-	G1/4
AEVC-B-G1F	38	20	11	G1/8	-
AEVC-B-G2F	38	20	11	G1/4	-

### Accessory Selection

Item	Model
S type Vertical mounting block-G1/4	AEVC-S-G2F
L type Vertical mounting block-G1/4	AEVC-L-G2F

Item	Model
B type Oval vertical mounting block-G1/8	AEVC-B-G1F
B type Oval vertical mounting block-G1/4	AEVC-B-G2F

# AZL Series

## Multistage Vacuum Generator

**AIRBEST**



### Features

- ◇ Multi-level and energy-efficient design
- ◇ Optional solenoid valve and pressure switch
- ◇ Built-in vacuum filter and silencer
- ◇ Vertical and lateral mounting holes for option

### Advantages

- ◇ Vacuum flow can be increased, save air consumption and shorten working cycle
- ◇ Control function is optional, no need of separate external connection to save space and reduce cost
- ◇ Minimize noise, the filter element is replaceable
- ◇ A variety of installation ways are available

### Applications

- ◇ Suitable for handling of cartons, metal sheet and plastics
- ◇ Suitable for occasions which require large vacuum flow, fast evacuation and low air consumption

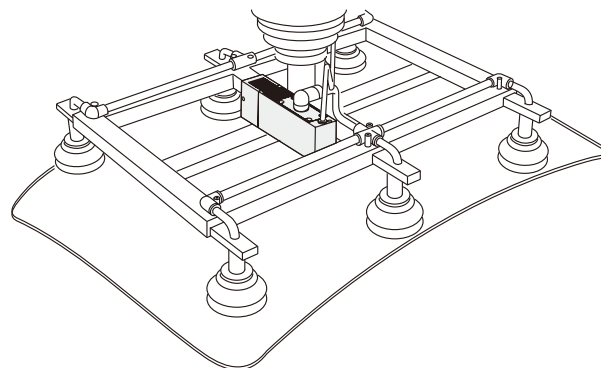

### Structure

- ◇ (1) Pressure switch
- ◇ (2) Vertical mounting hole
- ◇ (3) Lateral mounting hole
- ◇ (4) Exhaust port
- ◇ (5) Vacuum port
- ◇ (6) Air supply port
- ◇ (7) Vacuum release valve
- ◇ (8) Vacuum supply valve

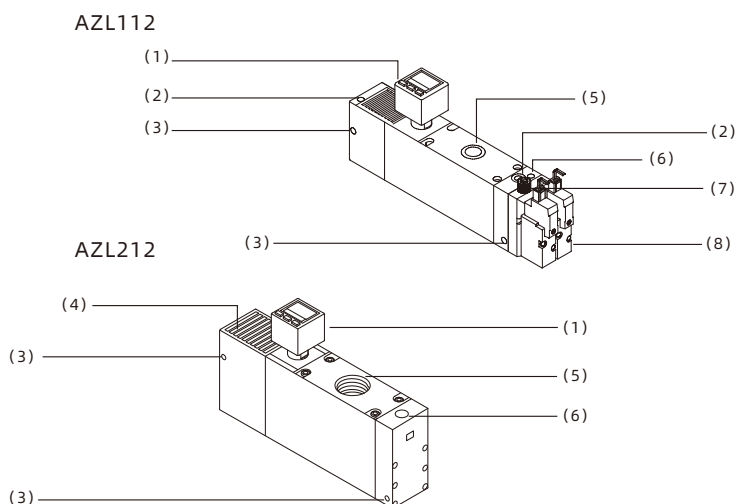

Vacuum Generator

AZK

AZQ

AZX

AZD

AGS

AGP

AGX

AGE

ABM/ABX

ABM/ABX  
Combined Type

AMC

AM/AL/AH

AM/AL  
Combined Type

AMD

AZW

AZR

ABT

ABP

ABQ

AEVC

**AZL**

ALH

AZH

AZU

ACV

ASBP

ALS

ACP

ACPF

ACPS

APB

# AZL Series

## Multistage Vacuum Generator

### How to order

## AZL 112 - A - DCN

①            ②            ③            ④

① Series	② Nozzle diameter	③ Control valve	④ Digital vacuum pressure switch
AZL	112 - 1×φ1.2mm 212 - 2×φ1.2mm	Nil - Without vacuum supply valve and vacuum release valve A - With vacuum supply valve and vacuum release valve	Nil - Default, without external vacuum port NP - With vacuum port Rc1/8, without pressure switch DCN - Compound pressure switch (-100.0~100.0kPa), 2NPN+V(1-5V) DCP - Compound pressure switch (-100.0~100.0kPa), 2PNP+V(1-5V)

### Selection-AZL112 Series

Model/Control valve Nil- Without control valve	A - With vacuum supply valve +vacuum release valve
AZL112	AZL112-A
AZL112-NP	AZL112-A-NP
AZL112-DCN	AZL112-A-DCN
AZL112-DCP	AZL112-A-DCP

### Selection-AZL212 Series

Model/Control valve Nil- Without control valve	A - With vacuum supply valve +vacuum release valve
AZL212	-
AZL212-NP	-
AZL212-DCN	-
AZL212-DCP	-

### Technical parameters

Model	Rated air supply pressure bar	Max. vacuum level -kPa	Max. vacuum flow NL/min	Air consumption NL/min	Noise level dB(A)	Working temperature °C	Recommended hose dia.(mm)	
							Air supply port (P)	Vacuum port (V)
AZL112	4.0	84	100	63	70	5~50	φ6	φ12
AZL212	4.0	84	200	126	77	5~50	φ8	φ12

◇ Note: Max.operating pressure 7bar, recommended air supply pressure range 2-5bar. Noise level is measured by the vacuum generator with built-in silencer. The Max. vacuum flow value is measured at a supply pressure of 6.0 bar.

### Vacuum flow(NL/min) at different vacuum levels(-kPa)

Model	Air supply pressure bar	Air consumption NL/min	Vacuum level (-kPa)										Max. vacuum level -kPa
			0	10	20	30	40	50	60	70	80		
AZL112	4.0	63	100.0	65.0	26.0	20.0	18.5	13.0	8.0	5.0	2.8	84	
AZL212	4.0	126	200.0	150.0	52.0	40.0	30.0	25.0	15.0	8.0	3.0	84	

### Evacuation time(s/L) to reach different vacuum levels(-kPa)

Model	Air supply pressure bar	Air consumption NL/min	Vacuum level (-kPa)										Max. vacuum level -kPa
			10	20	30	40	50	60	70	80			
AZL112	4.0	63	0.05	0.17	0.40	0.67	1.07	1.63	2.46	3.9	84		
AZL212	4.0	126	0.02	0.08	0.25	0.42	0.65	0.98	1.52	2.46	84		

# AZL Series

## Multistage Vacuum Generator

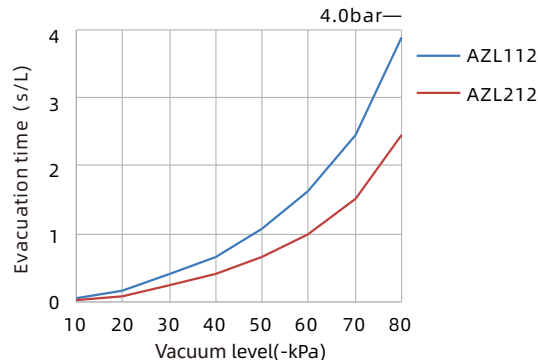
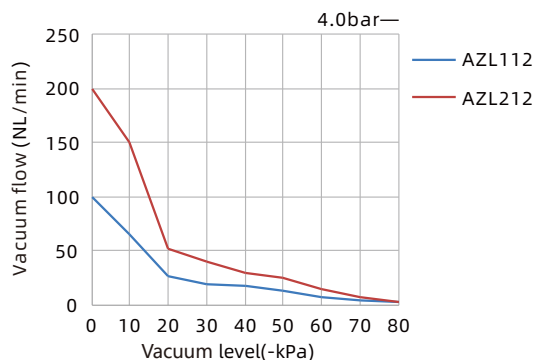

### Technical parameters- Control valve

Type of valve actuation	Internal pilot type NC (normally closed)
Operating pressure range	2.0~5.0bar
Rated voltage	24V
Ambient and fluid temperature	5~50°C
Response time(at 0.5Mpa)	25ms below
Max. operating frequency	5Hz
Manual operation	Slotted locking type

Pilot exhaust type	Individual exhaust,concentrated exhaust
Lubrication	Not required
Mounting position	Unrestricted
Impact/Vibration resistance	150/30m/s <sup>2</sup>
Enclosure	Dust-proof
Lead wire type	Direct lead out type, lead wire length 0.3m

### Dimensions(mm)

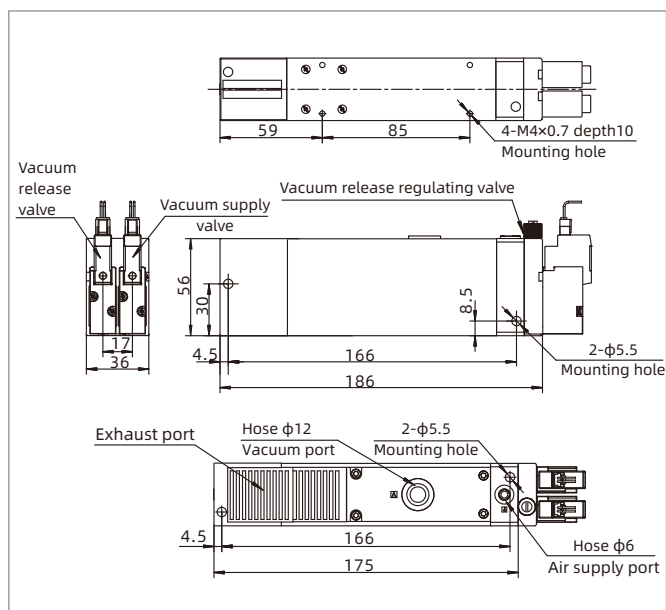

AZL112-A

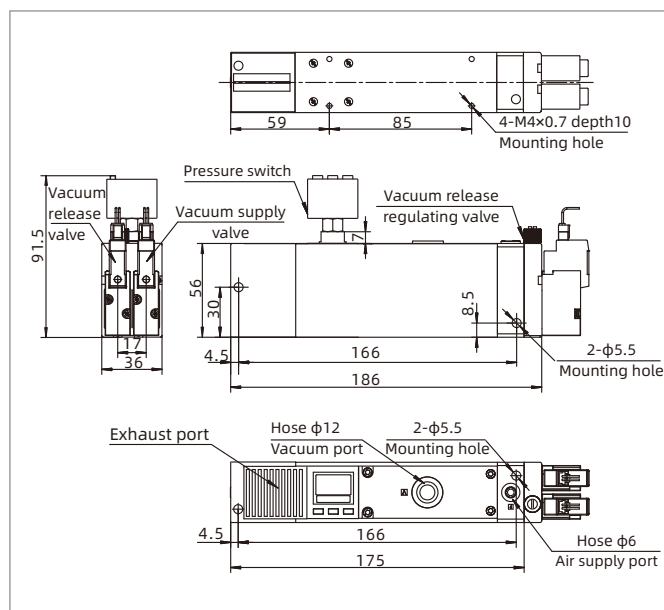

AZL112-A-DCN AZL112-A-DCP

# AZL Series

## Multistage Vacuum Generator



### Dimensions(mm)

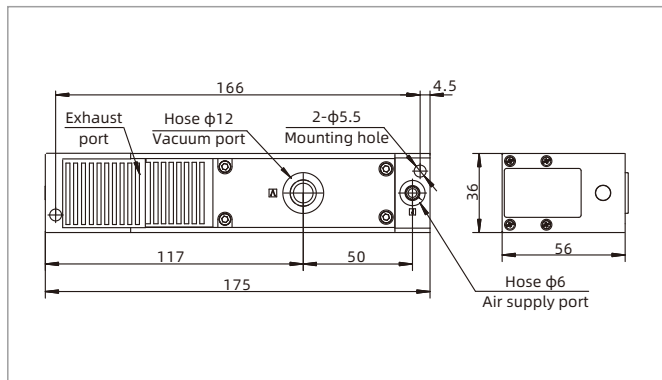

AZL112

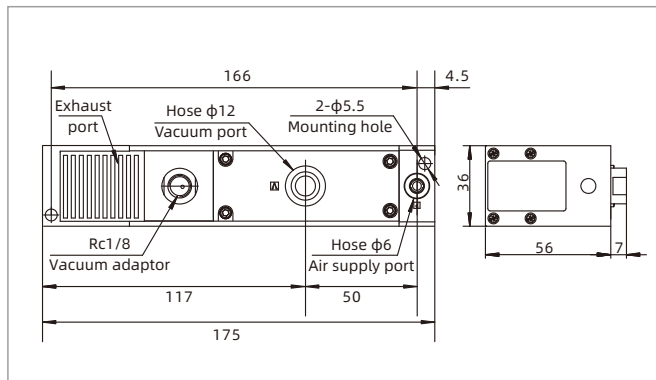

AZL112-NP

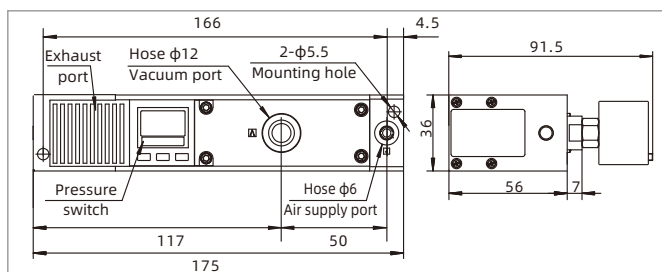

AZL112-DCN AZL112-DCP

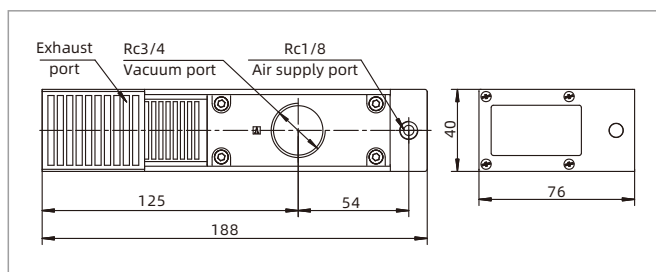

AZL212

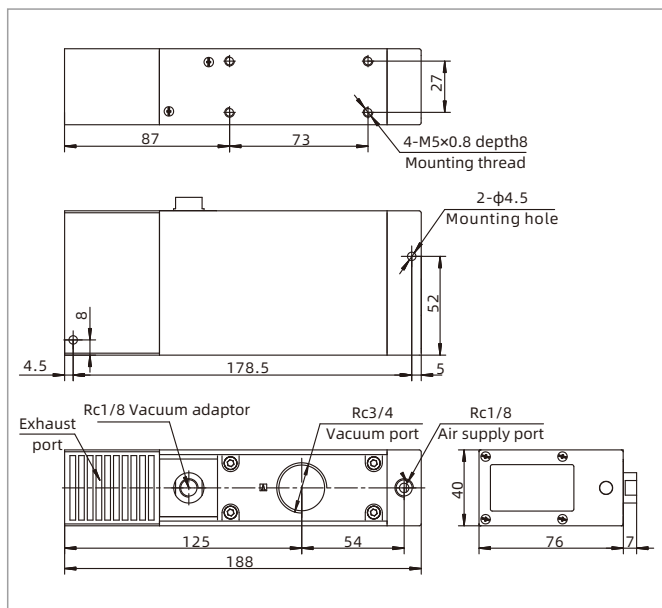

AZL212-NP

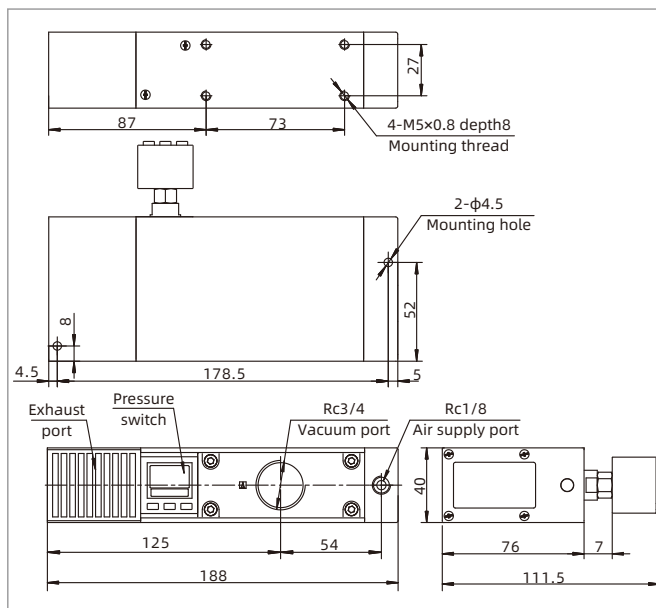

AZL212-DCN AZL212-DCP

# ALH Series

## Mini Vacuum Generator



UNIVERSAL



### Features

- ◇ Small size, light weight.
- ◇ Standard quick connector, connection, fast and convenient

### Advantage

- ◇ Standard quick connector, connection, fast and convenient
- ◇ Centralized exhaust option available
- ◇ Low noise level



### Application

- ◇ Suitable for handling electronic components and other small workpieces

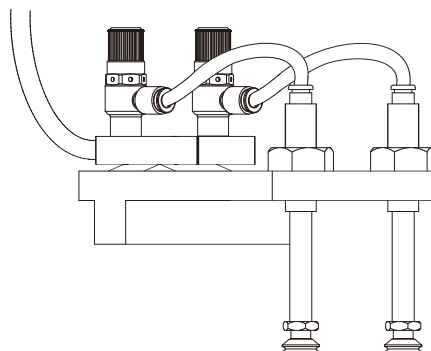

### Structure

- ◇ (1) Air supply port
- ◇ (2) Vacuum port
- ◇ (3) Exhaust port
- ◇ (4) Exhaust port

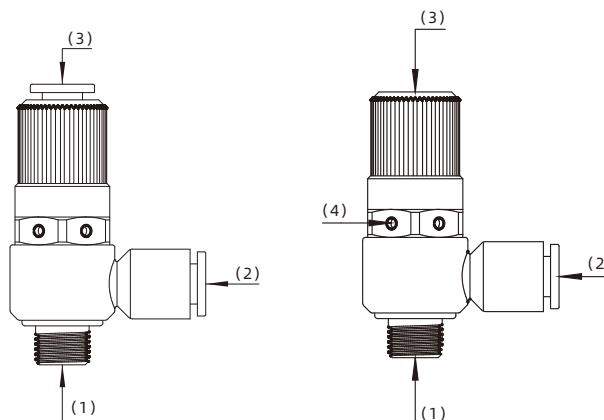

Vacuum Generator

- AZK
- AZQ
- AZX
- AZD
- AGS
- AGP
- AGX
- AGE
- ABM/ABX
- ABM/ABX Combined Type
- AMC
- AM/AL/AH
- AM/AL Combined Type
- AMD
- AZW
- AZR
- ABT
- ABP
- ABQ
- AEVC
- AZL
- ALH**
- AZH
- AZU
- ACV
- ASBP
- ALS
- ACP
- ACPF
- ACPS
- APB

# ALH Series

## Mini Vacuum Generator

### How to order

ALH 07 E - A6 - J

①      ②      ③      ④      ⑤

① Series	Nozzle diameter	③ Specification	④ Vacuum port specifications	⑤ Exhaust
ALH	07 - Nozzle diameter 0.7mm	E - Low air supply pressure type	A6 - $\phi 6$ quick connector	Nil - Default direct exhaust J - Centralized exhaust

### Technical parameters

Model	Rated air supply pressure bar	Air supply pressure range bar	Max. vacuum level -kPa	Max. vacuum flow NL/min	Air consumption NL/min	Noise level dB(A)	Weight g
ALH07E-A6	3.5	3.0~6.0	90	9.5	20	70	37
ALH07E-A6-J	3.5	3.0~6.0	90	9.5	20	-	40

### Vacuum flow(NL/min) at different vacuum levels(-kPa)

Model	0	10	20	30	40	50	60	70	80	Max. vacuum level -kPa
ALH07E	9.5	8.5	7.7	6.7	5.8	3.9	2.2	1.3	0.3	90

### Evacuation time(s/L) to reach different vacuum levels(-kPa)

Model	0	10	20	30	40	50	60	70	80	Max. vacuum level -kPa
ALH07E	0	0.7	1.5	2.5	3.8	5.3	7	9.5	15	90

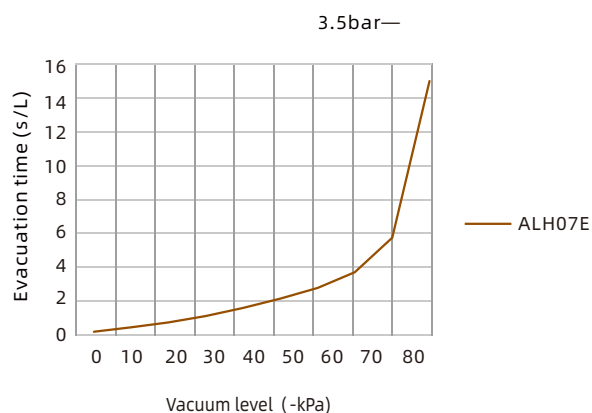
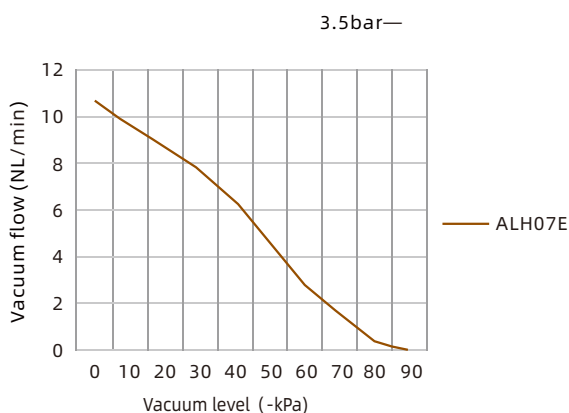

# ALH Series

## Mini Vacuum Generator

### Dimensions (mm)

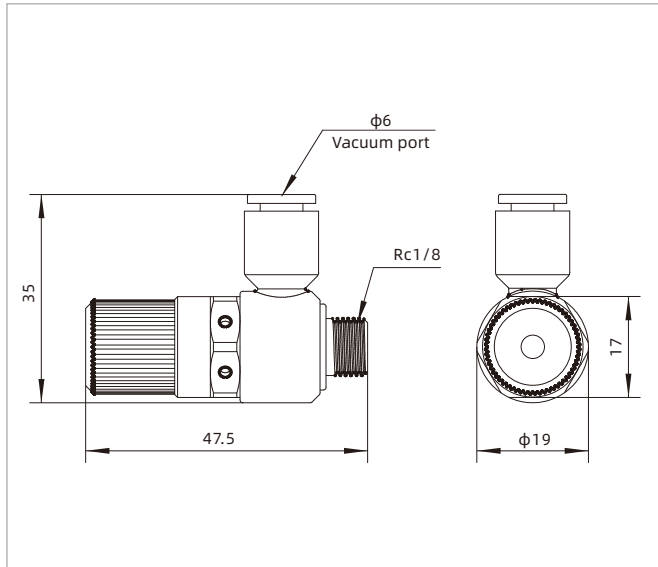

ALH07E-A6

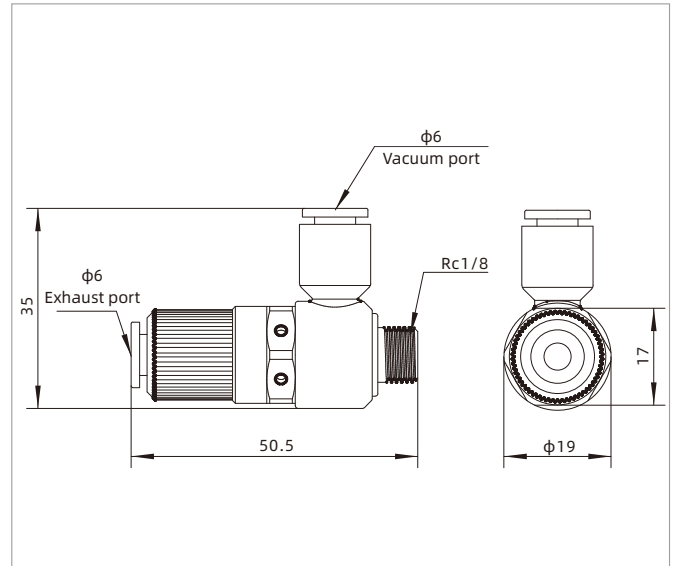

ALH07E-A6-J

Vacuum Generator

AZK

AZQ

AZX

AZD

AGS

AGP

AGX

AGE

ABM/ABX

ABM/ABX  
Combined Type

AMC

AM/AL/AH

AM/AL  
Combined Type

AMD

AZW

AZR

ABT

ABP

ABQ

AEVC

AZL

**ALH**

AZH

AZU

ACV

ASBP

ALS

ACP

ACPF

ACPS

APB

# AZH Series

## Basic Vacuum Generator

**AIRBEST**



### Features

- ◇ Single stage vacuum generator with plastic housing
- ◇ High vacuum level type and large vacuum flow type for option
- ◇ Body ported type and box type for option
- ◇ Thread connection or one-touch fitting for port connection

### Advantages

- ◇ Small size, light weight and cost-effective
- ◇ Suitable for various occasions
- ◇ Box type with built-in silencer to reduce noise
- ◇ Thread connection and one-touch fitting for option



### Applications

- ◇ Widely used in all kinds of vacuum systems
- ◇ Suitable for various handling operations such as automotive, metal sheet, wood, food and packaging, etc.
- ◇ High vacuum type and large flow type for different occasions

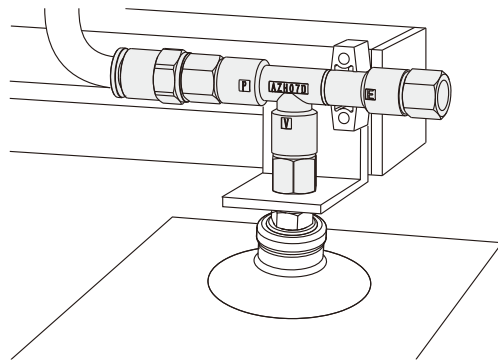

### Structure

- ◇ (1) Exhaust port
- ◇ (2) Air supply port
- ◇ (3) Vacuum port
- ◇ (4) Mounting hole

B - Box type

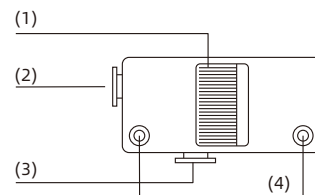

D - Body ported type

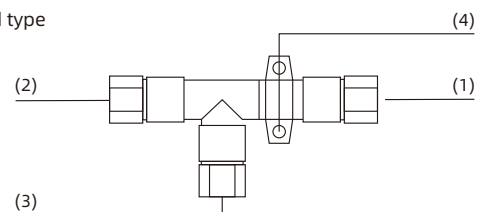

# AZH Series

## Basic Vacuum Generator

### How to order

**AZH 07 B S - 06 - 06**  
**AZH 07 D S - 01 - 01 - 01**  
 ①      ②      ③      ④      ⑤      ⑥      ⑦

① Series	② Nozzle diameter	③ Shape	④ Specification	⑤ Air supply port	⑥ Vacuum port	⑦ Exhaust port
AZH	05 - φ0.5mm	B - Box type	S - High vacuum level type (-88kPa)	06 - φ6 One-touch fitting	06 - φ6 One-touch fitting	06 - φ6 One-touch fitting
	07 - φ0.7mm	D - Body ported type	L - Large vacuum flow type (-48kPa)	08 - φ8 One-touch fitting	10 - φ10 One-touch fitting	08 - φ8 One-touch fitting
	10 - φ1.0mm			10 - φ10 One-touch fitting	12 - φ12 One-touch fitting	10 - φ10 One-touch fitting
	13 - φ1.3mm			12 - φ12 One-touch fitting	16 - φ16 One-touch fitting	12 - φ12 One-touch fitting
	15 - φ1.5mm			01 - Rc1/8 Female thread	01 - Rc1/8 Female thread	16 - φ16 One-touch fitting
	18 - φ1.8mm			02 - Rc1/4 Female thread	02 - Rc1/4 Female thread	01 - Rc1/8 Female thread
	20 - φ2.0mm			03 - Rc3/8 Female thread	03 - Rc3/8 Female thread	02 - Rc1/4 Female thread
					04 - Rc1/2 Female thread	03 - Rc3/8 Female thread
						04 - Rc1/2 Female thread

### Selection-Box type

Model/Shape BS		BL	
AZH05BS-06-06	AZH05BS-01-01	AZH05BL-06-06	AZH05BL-01-01
AZH07BS-06-06	AZH07BS-01-01	AZH07BL-06-06	AZH07BL-01-01
AZH10BS-06-06	AZH10BS-01-01	AZH10BL-06-06	AZH10BL-01-01
AZH13BS-08-10	AZH13BS-01-02	AZH13BL-08-10	AZH13BL-01-02

### Selection-Body ported type

Model/Shape DS		DL	
AZH05DS-06-06-06	AZH05DS-01-01-01	AZH05DL-06-06-06	AZH05DL-01-01-01
AZH07DS-06-06-06	AZH07DS-01-01-01	AZH07DL-06-06-06	AZH07DL-01-01-01
AZH10DS-06-06-08	AZH10DS-01-01-01	AZH10DL-06-06-08	AZH10DL-01-01-01
AZH13DS-08-10-10	AZH13DS-01-02-02	AZH13DL-08-10-10	AZH13DL-01-02-02
AZH15DS-10-12-12	AZH15DS-02-03-03	AZH15DL-10-12-12	AZH15DL-02-03-03
AZH18DS-12-12-12	AZH18DS-03-03-03	AZH18DL-12-12-12	AZH18DL-03-03-03
AZH20DS-12-16-16	AZH20DS-03-04-04	AZH20DL-12-16-16	AZH20DL-03-04-04

### Technical parameters

Model	Rated air supply pressure bar	Max. vacuum level -kPa		Max. vacuum flow NL/min		Air consumption NL/min	Noise level dB(A)	Working temperature °C	Weight g	Recommended hose dia.(mm)		
		S	L	S	L					Air supply port S	Vacuum port V	Exhaust port E
AZH05B	4.5	88	48	5	9	13.5	68	5~50	28	φ6	φ6	-
AZH07B	4.5	88	48	12	22	23.5	68	5~50	28	φ6	φ6	-
AZH10B	4.5	88	48	24	34	46.0	72	5~50	33	φ6	φ6	-
AZH13B	4.5	88	48	40	75	78.0	72	5~50	66	φ8	φ10	-

### Technical parameters

Model	Rated air supply pressure bar	Max. vacuum level -kPa		Max. vacuum flow NL/min		Air consumption NL/min	Noise level dB(A)	Working temperature °C	Weight g	Recommended hose dia.(mm)		
		S	L	S	L					Air supply port S	Vacuum port V	Exhaust port E
AZH05D	4.5	88	48	7.5	9	13.5	75	5~50	11	φ6	φ6	φ6
AZH07D	4.5	88	48	12	22	23.5	75	5~50	12	φ6	φ6	φ6
AZH10D	4.5	88	48	24	34	46.0	68	5~50	16	φ6	φ6	φ8
AZH13D	4.5	88	48	40	75	78.0	68	5~50	27	φ8	φ10	φ10
AZH15D	4.5	88	53	60	80	97.0	72	5~50	43	φ10	φ12	φ12
AZH18D	4.5	88	53	70	110	150.0	72	5~50	55	φ12	φ12	φ12
AZH20D	4.5	88	53	85	140	185.0	75	5~50	95	φ12	φ16	φ16

### Vacuum flow(NL/min) at different vacuum levels(-kPa)

Model	Air supply pressure bar	Air consumption NL/min	Vacuum level(-kPa)										Max. vacuum level -kPa
			0	10	20	30	40	50	60	70	80		
AZH05S	4.5	13.5	5.0	4.5	4.1	3.8	3.3	2.3	1.6	0.9	0.3	88	
AZH07S	4.5	23.5	12.0	11.0	10.0	9.0	8.0	7.0	5.5	2.1	0.8	88	
AZH10S	4.5	46.0	24.0	23.0	20.5	17.5	13.0	11.5	9.5	7.0	2.5	88	
AZH13S	4.5	78.0	40.0	35.0	32.5	28.0	23.0	19.5	13.0	9.0	4.5	88	
AZH15S	4.5	97.0	60.0	52.5	45.5	38.0	28.5	20.5	15.5	11.5	5.0	88	
AZH18S	4.5	150.0	70.0	62.0	52.0	45.0	38.0	26.0	22.0	16.5	8.5	88	
AZH20S	4.5	185.0	85.0	76.0	67.0	58.0	47.5	38.0	33.5	19.0	12.0	88	

### Evacuation time(s/L) to reach different vacuum levels(-kPa)

Model	Air supply pressure bar	Air consumption NL/min	Vacuum level(-kPa)								Max. vacuum level -kPa
			10	20	30	40	50	60	70		
AZH05S	4.5	13.5	0.89	1.70	3.20	5.00	7.80	12.00	19.00	88	
AZH07S	4.5	23.5	0.37	1.00	1.90	3.00	5.40	6.70	15.00	88	
AZH10S	4.5	46.0	0.25	0.60	1.25	2.00	2.90	4.60	7.30	88	
AZH13S	4.5	78.0	0.10	0.27	0.53	1.00	1.75	4.20	7.30	88	
AZH15S	4.5	97.0	0.04	0.21	0.35	0.63	1.23	4.10	6.50	88	
AZH18S	4.5	150.0	0.02	0.15	0.29	0.46	0.78	1.38	3.51	88	
AZH20S	4.5	185.0	0.02	0.12	0.21	0.34	0.55	0.85	1.58	88	

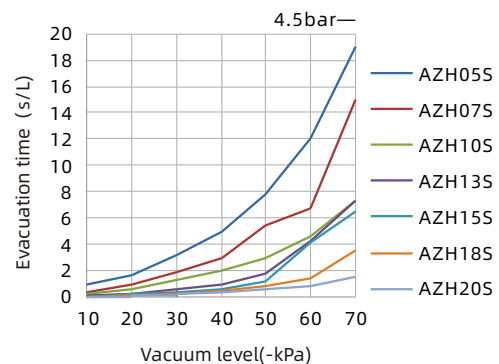
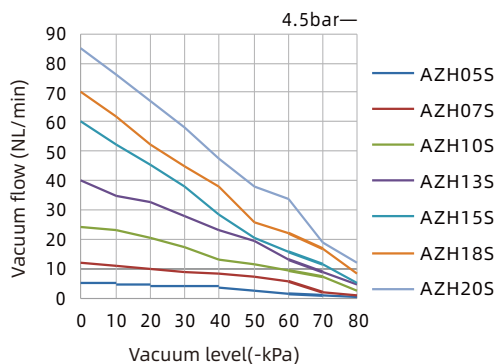

### Vacuum flow(NL/min) at different vacuum levels(-kPa)

Model	Air supply pressure bar	Air consumption NL/min	0	10	20	30	40	45	Max. vacuum level -kPa
AZH05L	4.5	13.5	9.0	8.0	7.0	6.0	3.0	1.9	48
AZH07L	4.5	23.5	22.0	21.0	20.5	15.5	10.5	6.8	48
AZH10L	4.5	46.0	34.0	32.0	26.0	19.0	12.0	8.0	48
AZH13L	4.5	78.0	75.0	72.0	65.0	43.0	19.0	9.0	48
AZH15L	4.5	97.0	80.0	72.0	60.0	45.0	36.5	16.0	53
AZH18L	4.5	150.0	110.0	105.0	95.0	80.0	55.0	30.0	53
AZH20L	4.5	185.0	140.0	130.0	120.0	100.0	80.0	62.0	53

### Evacuation time(s/L) to reach different vacuum levels(-kPa)

Model	Air supply pressure bar	Air consumption NL/min	10	20	30	40	45	Max. vacuum level -kPa
AZH05L	4.5	13.5	0.49	1.50	2.90	5.10	7.20	48
AZH07L	4.5	23.5	0.28	0.75	1.50	2.50	3.50	48
AZH10L	4.5	46.0	0.14	0.40	0.81	1.40	1.80	48
AZH13L	4.5	78.0	0.04	0.12	0.24	0.62	2.40	48
AZH15L	4.5	97.0	0.03	0.15	0.23	0.40	0.92	53
AZH18L	4.5	150.0	0.02	0.10	0.18	0.32	0.67	53
AZH20L	4.5	185.0	0.01	0.08	0.14	0.20	0.30	53

### Technical parameters

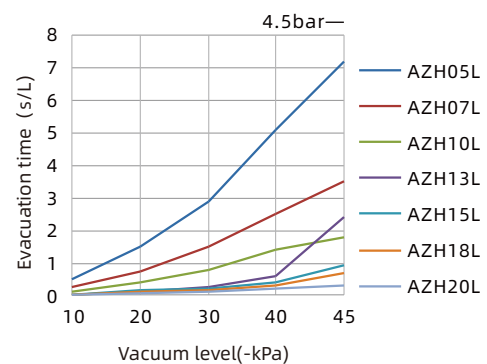
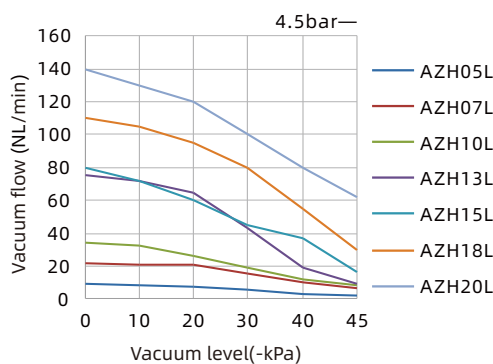

Vacuum Generator

AZK

AZQ

AZX

AZD

AGS

AGP

AGX

AGE

ABM/ABX

ABM/ABX Combined Type

AMC

AM/AL/AH

AM/AL Combined Type

AMD

AZW

AZR

ABT

ABP

ABQ

AEVC

AZL

ALH

**AZH**

AZU

ACV

ASBP

ALS

ACP

ACPF

ACPS

APB

# AZH Series

## Basic Vacuum Generator

### Dimensions(mm)

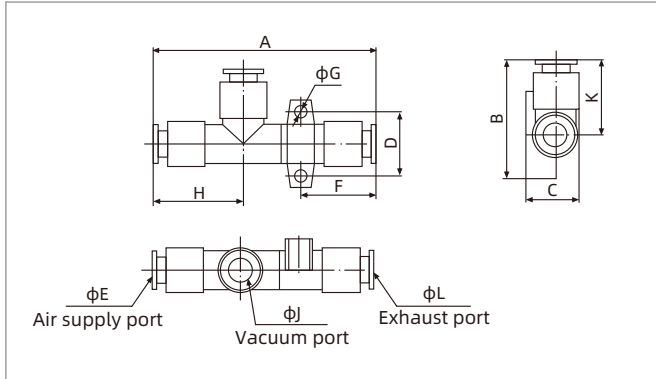

AZH - D Body ported type(One-touch fitting)

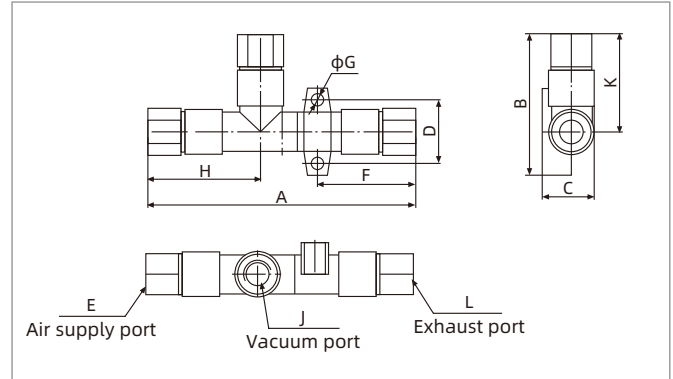

AZH - D Body ported type(Female thread connection)

Model/Size	A	B	C	D	E	F	G	H	L	K	J
AZH05DS-06-06-06	58.5	34.0	14.2	17.0	6	21.0	3.2	24.0	6	22.0	6
AZH07DS-06-06-06	61.0	34.0	14.2	17.0	6	22.0	3.2	24.0	6	22.0	6
AZH10DS-06-06-08	66.0	37.0	17.2	20.0	6	24.5	4.2	26.0	8	23.0	6
AZH10DL-06-06-08	70.0	37.0	17.2	20.0	6	24.5	4.2	26.0	8	23.0	6
AZH13DS-08-10-10	74.0	42.5	20.0	22.0	8	27.0	4.2	28.0	10	27.5	10
AZH13DL-08-10-10	79.5	42.5	20.0	22.0	8	27.0	4.2	28.0	10	27.5	10
AZH15DS-10-12-12	93.3	47.0	22.5	27.0	10	32.8	4.2	31.5	12	29.5	12
AZH18DS-12-12-12	114.0	41.0	21.0	10.0	12	50.0	3.5	35.5	12	30.5	12
AZH20DS-12-16-16	124.6	46.0	27.0	12.0	12	54.3	3.5	38.5	16	32.7	16

AZH - D Body ported type(One-touch fitting)

Model/Size	A	B	C	D	E	F	G	H	L	K	J
AZH05DS-01-01-01	73.5	41.5	14.2	17.0	Rc1/8	28.5	3.2	31.5	Rc1/8	29.5	Rc1/8
AZH07DS-01-01-01	76.0	41.5	14.2	17.0	Rc1/8	29.5	3.2	31.5	Rc1/8	29.5	Rc1/8
AZH10DS-01-01-01	82.0	44.5	17.2	20.0	Rc1/8	33.0	4.2	33.5	Rc1/8	30.5	Rc1/8
AZH10DL-01-01-01	86.0	44.5	17.2	20.0	Rc1/8	33.0	4.2	33.5	Rc1/8	30.5	Rc1/8
AZH13DS-01-02-02	94.5	54.0	20.0	22.0	Rc1/8	38.5	4.2	36.5	Rc1/4	39.0	Rc1/4
AZH13DL-01-02-02	99.5	54.0	20.0	22.0	Rc1/8	38.5	4.2	36.5	Rc1/4	39.0	Rc1/4
AZH15DS-02-03-03	116.5	58.5	22.5	27.0	Rc1/4	44.5	4.2	43.0	Rc3/8	41.0	Rc3/8
AZH18DS-03-03-03	133.0	52.5	21.0	10.0	Rc3/8	57.5	3.5	47.0	Rc3/8	42.0	Rc3/8
AZH20DS-03-04-04	151.0	61.0	27.0	12.0	Rc3/8	69.3	3.5	50.0	Rc1/2	47.7	Rc1/2

AZH - D Body ported type(Female thread connection)

# AZH Series

## Basic Vacuum Generator

### Dimensions(mm)

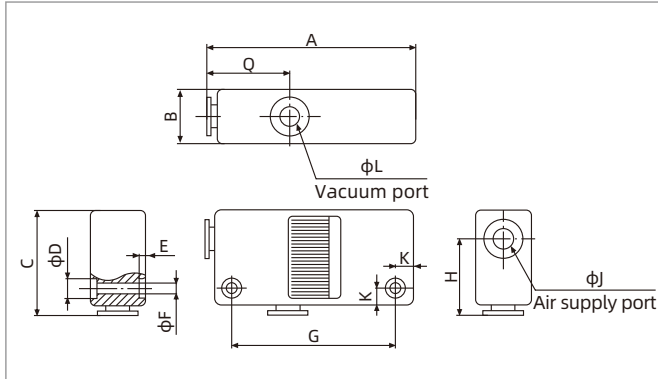

AZH - B Box type(One-touch fitting)

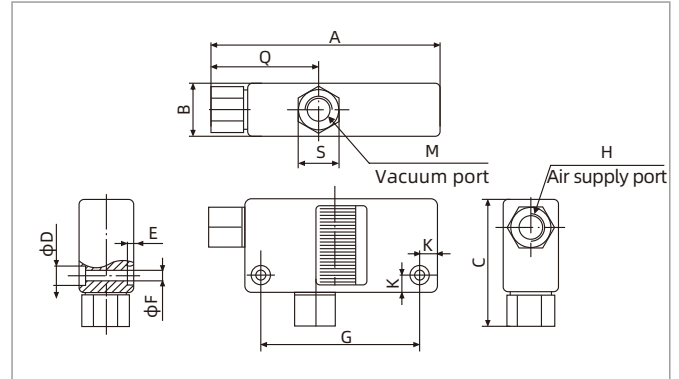

AZH - B Box type(Female thread connection)

Model/Size	A	B	C	D	E	F	G	H	Q	L	K	J
AZH05B-06-06	60	16	31	5.8	2	3.2	47	22	24	6	5	6
AZH07B-06-06	60	16	31	5.8	2	3.2	47	22	24	6	5	6
AZH10B-06-06	63	18	32	5.8	2	3.2	50	23	26	6	5	6
AZH13B-08-10	78	23	38.5	7.5	3	4.2	61	27.5	28	10	7	8

AZH - B Box type(One-touch fitting)

Model/Size	A	B	C	D	E	F	G	H	Q	M	K	S
AZH05B-01-01	68	16	39	5.8	2	3.2	47	Rc1/8	31.5	Rc1/8	5	12
AZH07B-01-01	68	16	39	5.8	2	3.2	47	Rc1/8	31.5	Rc1/8	5	12
AZH10B-01-01	71	18	40	5.8	2	3.2	50	Rc1/8	33.5	Rc1/8	5	12
AZH13B-01-02	86.5	23	50	7.5	3	4.2	61	Rc1/8	36.5	Rc1/4	7	14

AZH - B Box type(Female thread connection)

Vacuum Generator

AZK

AZQ

AZX

AZD

AGS

AGP

AGX

AGE

ABM/ABX

ABM/ABX  
Combined Type

AMC

AM/AL/AH

AM/AL  
Combined Type

AMD

AZW

AZR

ABT

ABP

ABQ

AEVC

AZL

ALH

AZH

AZU

ACV

ASBP

ALS

ACP

ACPF

ACPS

APB

# AZU Series

## Basic Vacuum Generator

**AIRBEST**



ELECTRONICS



### Features

- ◇ Axial connection
- ◇ Plastic housing
- ◇ High vacuum type and large flow type for option

### Advantages

- ◇ Installing directly to hose
- ◇ Suitable for small space
- ◇ Easy installation, no additional installation accessories are required



### Applications

- ◇ Linear type to install to PU hose directly
- ◇ Suitable for handling system of limited space
- ◇ Handling of electronic components

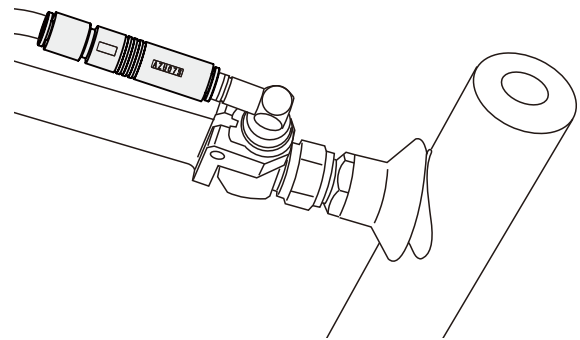

### Structure

- ◇ (1) Air supply port
- ◇ (2) Exhaust port
- ◇ (3) Vacuum port

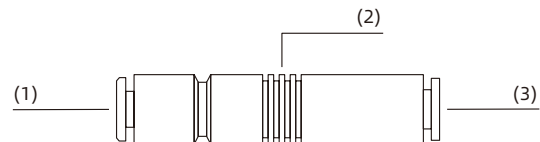

# AZU Series

## Basic Vacuum Generator

### How to order

## AZU 05 S

① ② ③

① Series	② Nozzle diameter	③ Specification
AZU	05 - $\phi$ 0.5mm 07 - $\phi$ 0.7mm	S - High vacuum level type (-85kPa) L - Large vacuum flow type (-48kPa)

### Selection

Model/Nozzle diameter	05	07
AZU□S	AZU05S	AZU07S
AZU□L	AZU05L	AZU07L

### Technical parameters

Model	Nozzle diameter mm	Rated air supply pressure bar	Max. vacuum level -kPa	Max. vacuum flow NL/min	Air consumption NL/min	Noise level dB(A)	Working temperature °C	Weight g	Recommended hose dia.(mm)	
									Air supply port P	Vacuum port V
AZU05S	0.5	4.5	85	7	9	68	5~60	6.5	$\phi$ 6	$\phi$ 6
AZU07S	0.7	4.5	85	12	19	68	5~60	7.0	$\phi$ 6	$\phi$ 6
AZU05L	0.5	4.5	48	12	9	70	5~60	6.5	$\phi$ 6	$\phi$ 6
AZU07L	0.7	4.5	48	21	19	70	5~60	7.0	$\phi$ 6	$\phi$ 6

◇ Note: Max. operating pressure 7bar, standard operating pressure 4.5bar

### Vacuum flow(NL/min) at different vacuum levels(-kPa)

Model	Air supply pressure bar	Air consumption NL/min	Vacuum level (-kPa)											Max. vacuum level -kPa
			0	10	20	30	40	48	50	60	70	80		
AZU05S	4.5	9	7.0	6.0	5.0	4.0	3.5	-	2.5	1.8	1.0	0.4	85	
AZU07S	4.5	19	12.0	9.5	8.5	7.2	6.0	-	5.5	4.0	2.0	0.4	85	
AZU05L	4.5	9	12.0	10.0	8.0	5.5	3.0	1.0	-	-	-	-	48	
AZU07L	4.5	19	21.0	18.5	15.5	11.5	8.0	1.5	-	-	-	-	48	

### Evacuation time(s/L) to reach different vacuum levels(-kPa)

Model	Air supply pressure bar	Air consumption NL/min	Vacuum level (-kPa)								Max. vacuum level -kPa
			10	20	30	40	45	50	60		
AZU05S	4.5	9	0.90	2.6	5.2	10.0	-	22.5	-	85	
AZU07S	4.5	19	0.53	1.4	2.7	5.0	-	8.7	18	85	
AZU05L	4.5	9	0.60	1.5	2.9	8.0	14.0	-	-	48	
AZU07L	4.5	19	0.34	0.9	2.0	7.5	13.0	-	-	48	

# AZU Series

## Basic Vacuum Generator

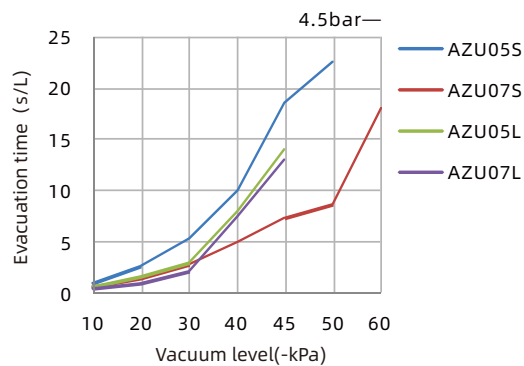
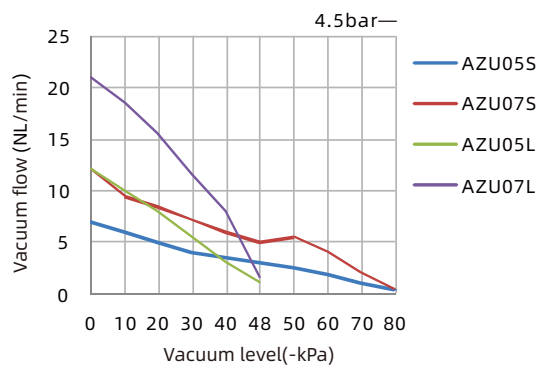

### Dimensions(mm)

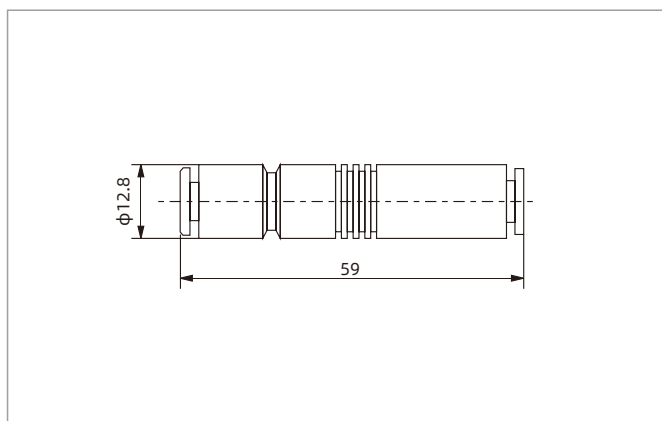

AZU05

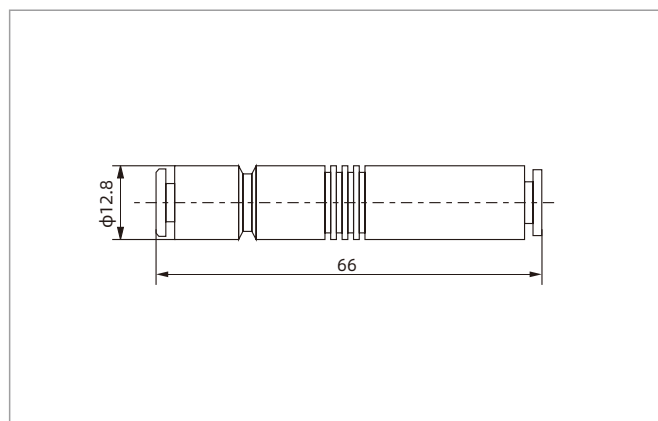

AZU07

# ACV Series

## Basic Vacuum Generator

**AIRBEST**



UNIVERSAL



### Features

- ◇ Single stage and compact structure
- ◇ High vacuum level type and large flow type for option
- ◇ Optional pressure switch

### Advantages

- ◇ Long lifetime and easy maintenance
- ◇ Meeting all kinds of working conditions
- ◇ Cost-effective and simple pressure switch for detecting directly

### Applications

- ◇ Widely used in all kinds of vacuum systems
- ◇ Suitable for various handling operations such as automotive, metal sheet, wood, food and packaging, etc.
- ◇ High vacuum type and large flow type for different occasions
- ◇ Simple structure, the metal nozzle and body can be used in occasions of complicated environment, it is easy to maintain and clean

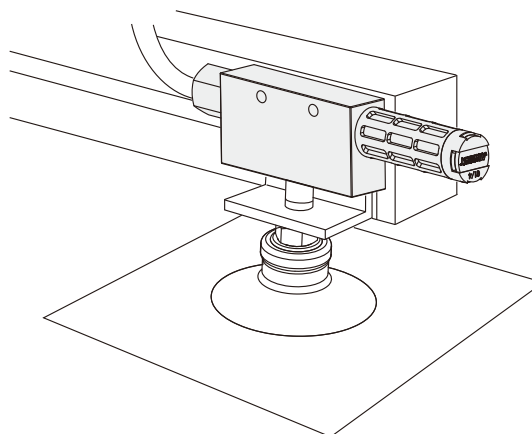

### Structure

- ◇ (1) Air supply port
- ◇ (2) Vacuum port
- ◇ (3) Silencer
- ◇ (4) Pressure switch
- ◇ (5) Adjusting nut

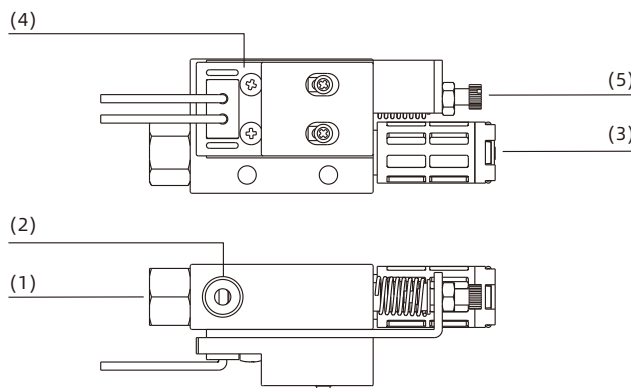

Vacuum Generator

AZK

AZQ

AZX

AZD

AGS

AGP

AGX

AGE

ABM/ABX

ABM/ABX  
Combined Type

AMC

AM/AL/AH

AM/AL  
Combined Type

AMD

AZW

AZR

ABT

ABP

ABQ

AEVC

AZL

ALH

AZH

AZU

**ACV**

ASBP

ALS

ACP

ACPF

ACPS

APB

# ACV Series

## Basic Vacuum Generator

### How to order

## ACV - 10 HS CK

①                      ②                      ③                      ④

① Series	② Nozzle diameter	③ Specification	④ Pressure switch
ACV	05 - $\phi$ 0.5mm	HS - High vacuum level type (-87kPa)	Nil - Without pressure switch
	10 - $\phi$ 1.0mm	LS - Large vacuum flow type (-57kPa)	CK - With adjustable pressure switch
	15 - $\phi$ 1.5mm		
	20 - $\phi$ 2.0mm		
	25 - $\phi$ 2.5mm		
	30 - $\phi$ 3.0mm		

### Selection

Model/Pressure switch Nil-Without pressure switch		Model/Pressure switch Nil-Without pressure switch	
CK-With adjustable pressure switch		CK-With adjustable pressure switch	
ACV-05HS	ACV-05HSCK	ACV-05LS	ACV-05LSCK
ACV-10HS	ACV-10HSCK	ACV-10LS	ACV-10LSCK
ACV-15HS	ACV-15HSCK	ACV-15LS	ACV-15LSCK
ACV-20HS	ACV-20HSCK	ACV-20LS	ACV-20LSCK
ACV-25HS	-	ACV-25LS	-
ACV-30HS	-	ACV-30LS	-

### Technical parameters

Model	Rated air supply pressure bar	Max. vacuum level -kPa	Max. vacuum flow NL/min	Air consumption NL/min	Noise level dB(A)	Working temperature °C	Weight(g)		Recommended hose dia.(mm)	
							Without switch	CK	Air supply port (P)	Vacuum port (V)
ACV-05HS	5.0	87	7	13	68	0~60	80	120	$\phi$ 8	$\phi$ 8
ACV-10HS	5.0	90	27	44	68	0~60	80	120	$\phi$ 8	$\phi$ 8
ACV-15HS	5.0	90	63	100	72	0~60	140	190	$\phi$ 8	$\phi$ 8
ACV-20HS	5.0	90	110	180	72	0~60	350	460	$\phi$ 8	$\phi$ 10
ACV-25HS	5.0	90	160	265	75	0~60	730	700	$\phi$ 10	$\phi$ 12
ACV-30HS	5.0	90	225	385	75	0~60	870	846	$\phi$ 10	$\phi$ 12
ACV-05LS	5.0	57	10	13	68	0~60	75	115	$\phi$ 8	$\phi$ 8
ACV-10LS	5.0	57	36	44	68	0~60	75	115	$\phi$ 8	$\phi$ 8
ACV-15LS	5.0	57	95	100	72	0~60	135	180	$\phi$ 8	$\phi$ 8
ACV-20LS	5.0	57	170	180	72	0~60	330	440	$\phi$ 8	$\phi$ 10
ACV-25LS	5.0	57	250	265	75	0~60	710	680	$\phi$ 10	$\phi$ 12
ACV-30LS	5.0	57	350	385	75	0~60	840	816	$\phi$ 10	$\phi$ 12

# ACV Series

## Basic Vacuum Generator

### Vacuum flow(NL/min) at different vacuum levels(-kPa)

Model	Air supply pressure bar	Air consumption NL/min	0	10	20	30	40	50	60	70	80	Max. vacuum level -kPa
ACV-05HS	5.0	13	7.0	5.5	4.2	3.0	1.5	0.8	0.5	0.2	0.05	87
ACV-10HS	5.0	44	27.0	19.0	16.0	14.5	13.0	10.5	8.0	6.5	2.50	90
ACV-15HS	5.0	100	63.0	55.0	44.0	37.0	32.5	25.0	18.0	14.0	9.00	90
ACV-20HS	5.0	180	110.0	100.0	85.0	75.0	55.0	40.5	30.0	20.0	12.00	90
ACV-25HS	5.0	265	160.0	155.0	140.0	120.0	95.0	72.0	47.0	28.0	15.00	90
ACV-30HS	5.0	385	225.0	200.0	160.0	135.0	105.0	78.0	55.0	33.0	19.00	90

### Evacuation time(s/L) to reach different vacuum levels(-kPa)

Model	Air supply pressure bar	Air consumption NL/min	10	20	30	40	50	60	70	80	Max. vacuum level -kPa
ACV-05HS	5.0	13	0.68	1.38	2.77	4.32	6.02	8.25	9.44	11.82	87
ACV-10HS	5.0	44	0.20	0.49	0.82	1.25	1.74	2.32	2.95	4.00	90
ACV-15HS	5.0	100	0.08	0.19	0.32	0.48	0.69	0.92	1.38	1.95	90
ACV-20HS	5.0	180	0.04	0.10	0.17	0.23	0.34	0.49	0.71	0.92	90
ACV-25HS	5.0	265	0.03	0.07	0.11	0.17	0.24	0.35	0.49	0.75	90
ACV-30HS	5.0	385	0.03	0.06	0.09	0.14	0.20	0.27	0.41	0.63	90

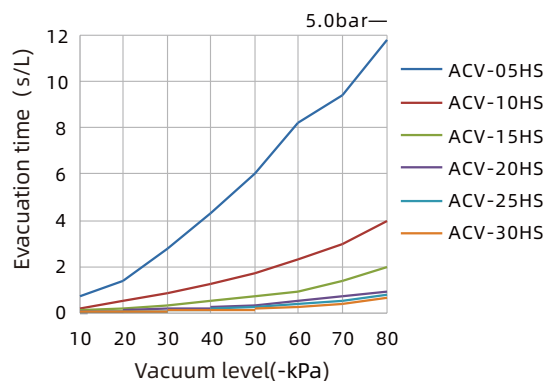
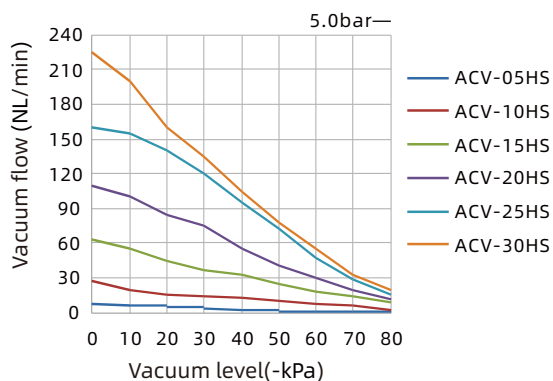

### Vacuum flow(NL/min) at different vacuum levels(-kPa)

Model	Air supply pressure bar	Air consumption NL/min	0	10	20	30	40	50	55	Max. vacuum level -kPa
ACV-05LS	5.0	13	10.0	9.0	8.0	6.5	2.5	1.8	0.7	57
ACV-10LS	5.0	44	36.0	31.5	23.5	16.5	10.0	6.5	2.5	57
ACV-15LS	5.0	100	95.0	85.0	70.0	47.5	30.5	15.5	5.5	57
ACV-20LS	5.0	180	170.0	125.0	115.0	95.0	70.0	35.5	7.5	57
ACV-25LS	5.0	265	250.0	215.0	200.0	150.0	105.0	60.0	36.0	57
ACV-30LS	5.0	385	350.0	295.0	267.0	215.0	150.0	85.0	41.0	57

Vacuum Generator

AZK

AZQ

AZX

AZD

AGS

AGP

AGX

AGE

ABM/ABX

ABM/ABX Combined Type

AMC

AM/AL/AH

AM/AL Combined Type

AMD

AZW

AZR

ABT

ABP

ABQ

AEVC

AZL

ALH

AZH

AZU

ACV

ASBP

ALS

ACP

ACPF

ACPS

APB

# ACV Series

## Basic Vacuum Generator

### Evacuation time(s/L) to reach different vacuum levels(-kPa)

Model	Air supply pressure bar	Air consumption NL/min	10	20	30	40	50	55	Max. vacuum level -kPa
ACV-05LS	5.0	13	0.31	0.98	1.89	3.17	5.12	6.70	57
ACV-10LS	5.0	44	0.12	0.28	0.51	0.83	1.32	1.40	57
ACV-15LS	5.0	100	0.45	0.10	0.15	0.26	0.42	0.56	57
ACV-20LS	5.0	180	0.03	0.06	0.11	0.14	0.25	0.34	57
ACV-25LS	5.0	265	0.02	0.05	0.08	0.12	0.18	0.30	57
ACV-30LS	5.0	385	0.02	0.04	0.06	0.09	0.13	0.22	57

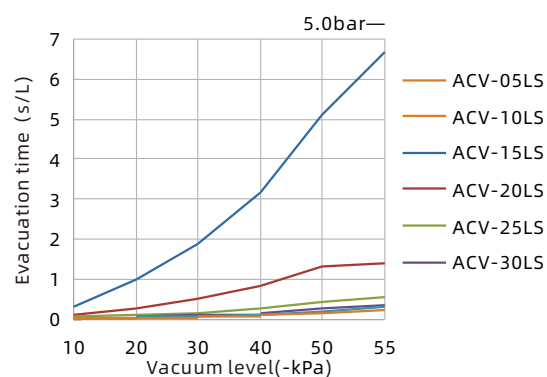
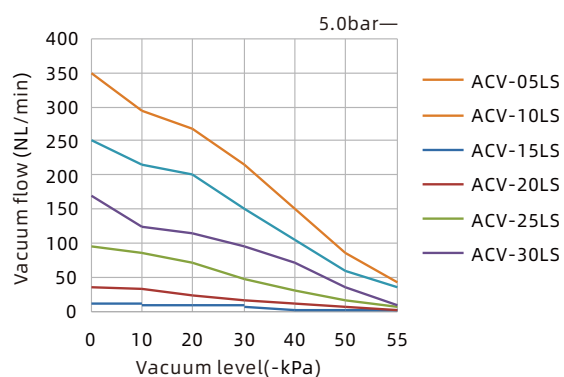

### Technical parameters-Pressure switch

Model	ACV-CK (Adjustable pressure switch)
Fluid	Air
Set pressure range(-kPa)	20~53
Ambient temperature	0~60°C (Non-freezing)
Operating accuracy(-kPa)	±5.3
Hysteresis(-kPa)	4.0~13.3
Operating voltage(V)	DC24V below
Load current(A)	0.2
Effective length of lead wire(m)	0.7

### Air circuit schematic diagram

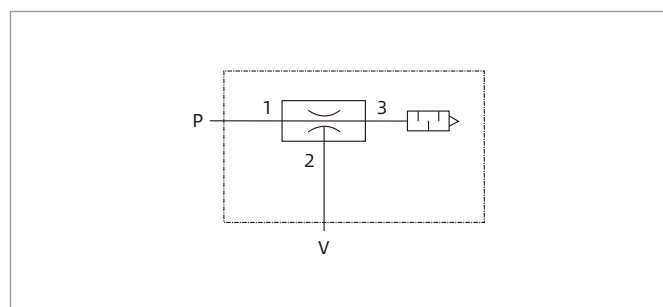

ACV Standard

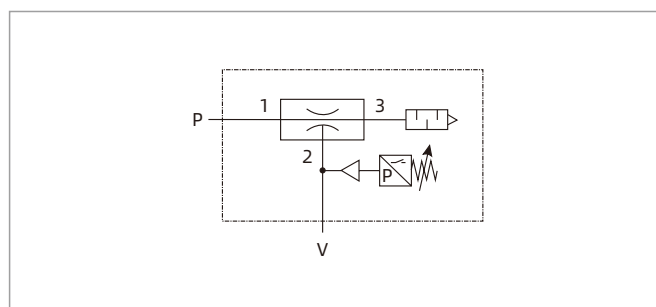

ACV - CK With pressure switch

# ACV Series

## Basic Vacuum Generator

### Dimensions(mm)

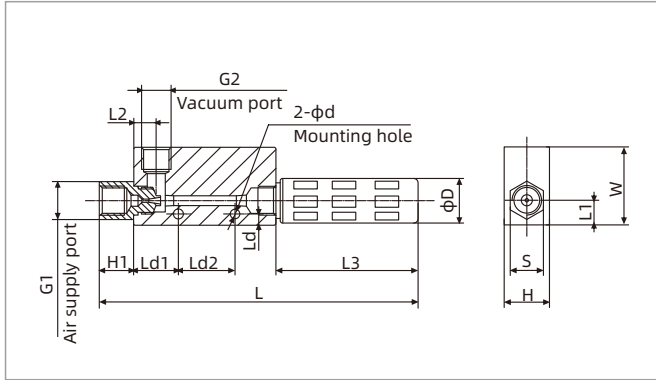

ACV Standard

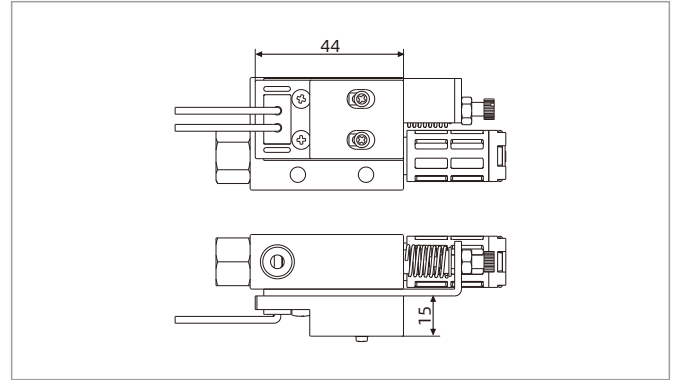

ACV - CK With pressure switch

Model/Size	L	H	W	G1	H1	L1	S	G2	L2	$\phi d$	Ld	Ld1	Ld2	$\phi D$	L3
ACV-05	85	16	33	Rp1/8	10	10	14	Rp1/8	8	4.5	4.5	14	20	15	30
ACV-10	85	16	33	Rp1/8	10	10	14	Rp1/8	8	4.5	4.5	14	20	15	30
ACV-15	129	20	35	Rp1/4	15	11	17	Rp1/4	10	4.5	5.0	20	25	19	51
ACV-20	161	30	40	Rp1/4	20	15	24	Rp3/8	13	6.0	7.0	28	32	28	56
ACV-20CK	161	30	50	Rp1/4	20	15	24	Rp3/8	13	6.0	7.0	28	32	28	56
ACV-25	236	40	60	Rc3/8	17	20	27	Rc1/2	16	6.0	5.5	20	50	40	119
ACV-30	257	40	60	Rc1/2	20	20	30	Rc3/4	20	6.0	5.5	33	50	40	119

### Repair kits

Model of silencer	Connection thread	Color	Applicable vacuum generator
ZSB-X-G1M	G1/8Male thread		ACV-05HS、10HS
ZSB-F-G1M	G1/8Male thread		ACV-05LS、10LS
ZSB-X-G2M	G1/4Male thread		ACV-15HS
ZSB-F-G2M	G1/4Male thread		ACV-15LS
ZSB-X-G4M	G1/2Male thread		ACV-20HS
ZSB-F-G4M	G1/2Male thread		ACV-20LS
ZSA-G6M	G3/4Male thread		ACV-25HS /LS、30HS / LS

Vacuum Generator

AZK

AZQ

AZX

AZD

AGS

AGP

AGX

AGE

ABM/ABX

ABM/ABX  
Combined Type

AMC

AM/AL/AH

AM/AL  
Combined Type

AMD

AZW

AZR

ABT

ABP

ABQ

AEVC

AZL

ALH

AZH

AZU

**ACV**

ASBP

ALS

ACP

ACPF

ACPS

APB

# ASBP Series

## Basic Vacuum Generator

**AIRBEST**



UNIVERSAL

RoHS

### Features

- ◇ Plastic housing, small size and light weight
- ◇ Nozzle diameter 1.0mm and 1.5mm
- ◇ Threaded connection

### Advantages

- ◇ Suitable for fast handling
- ◇ Low air consumption
- ◇ Easy installation and space saving
- ◇ Low noise and easy maintenance



### Applications

- ◇ Basic vacuum generator with plastic housing
- ◇ Compact structure, can be installed in row
- ◇ Handling of electronic components

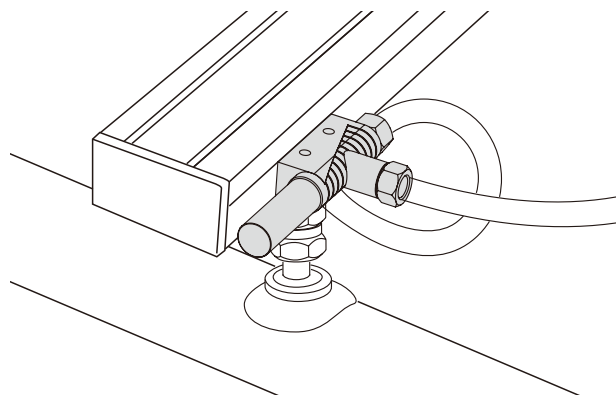

### Structure

- ◇ (1) Air supply port
- ◇ (2) Vacuum port
- ◇ (3) Mounting hole
- ◇ (4) Exhaust port

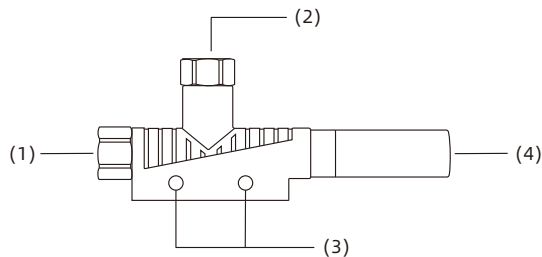

# ASBP Series

## Basic Vacuum Generator

### How to order

## ASBP 10

① ②

① Series	② Nozzle diameter
ASBP	10 - $\phi$ 1.0mm 15 - $\phi$ 1.5mm

### Selection

Model/Nozzle diameter	10	15
ASBP□	ASBP10	ASBP15

### Technical parameters

Model	Nozzle diameter mm	Rated air supply pressure bar	Max. vacuum level -kPa	Max. vacuum flow NL/min	Air consumption NL/min	Noise level dB(A)	Working temperature °C	Weight g	Recommended hose dia.(mm)	
									Air supply port P	Vacuum port V
ASBP10	1.0	4.5	85	38	50	59	0~60	22	$\phi$ 6	$\phi$ 8
ASBP15	1.5	4.5	85	72	110	65	0~60	22	$\phi$ 6	$\phi$ 8

◇ Note: Max.operating pressure 7bar, standard operating pressure 4.5bar

AZK

AZQ

AZX

AZD

AGS

AGP

AGX

AGE

ABM/ABX

ABM/ABX  
Combined Type

AMC

AM/AL/AH

AM/AL  
Combined Type

AMD

AZW

AZR

ABT

ABP

ABQ

AEVC

AZL

ALH

AZH

AZU

ACV

**ASBP**

ALS

ACP

ACPF

ACPS

APB

# ASBP Series

## Basic Vacuum Generator

### Vacuum flow(NL/min) at different vacuum levels(-kPa)

Model	Air supply pressure bar	Air consumption NL/min	0	10	20	30	40	50	60	70	80	Max. vacuum level -kPa
ASBP10	4.5	50	38	30	26	23	18.6	16	11	7.0	1.8	85
ASBP15	4.5	110	72	60	52	44	36.0	30	24	15.5	2.2	85

### Evacuation time(s/L) to reach different vacuum levels(-kPa)

Model	Air supply pressure bar	Air consumption NL/min	10	20	30	40	50	60	70	Max. vacuum level -kPa
ASBP10	4.5	50	0.13	0.33	0.60	1.00	1.72	3.00	-	85
ASBP15	4.5	110	0.06	0.18	0.32	0.52	0.81	1.32	2.7	85

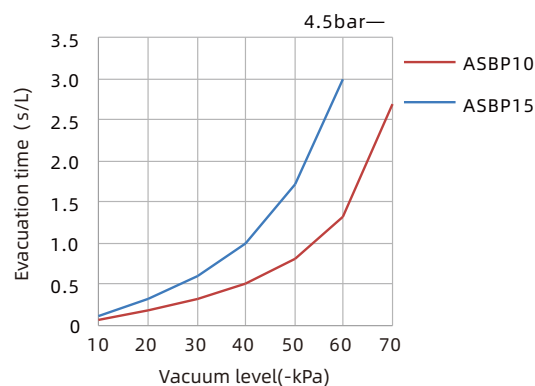
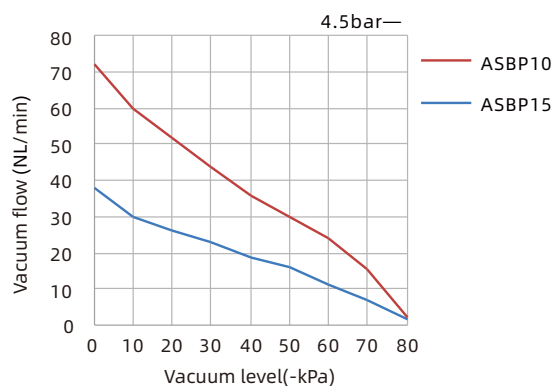

### Dimensions(mm)

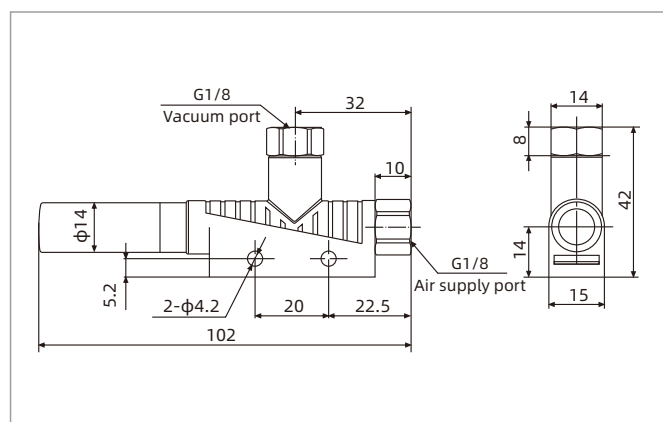

ASBP

# ALS Series

## Linear Single Stage Vacuum Generator



UNIVERSAL



### Features

- ◇ It is installed directly between suction cup and compressed air source
- ◇ Aluminum alloy body, small size, light weight

### Advantages

- ◇ No need to connect PU hose, it can directly produce vacuum at the working site
- ◇ Saving space, suitable for installation occasions with small space and fast movement



### Applications

- ◇ The linear vacuum generator is connected with the suction cup and the compressed air source directly, which can reduce the evacuation time
- ◇ Suitable for a variety of handling process, such as industrial robots and feeding systems

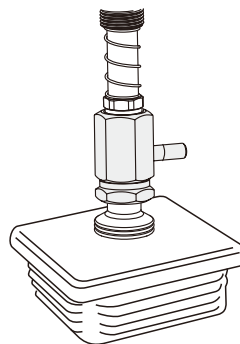

### Structure

- ◇ (1) Air supply port
- ◇ (2) Exhaust port
- ◇ (3) Vacuum port

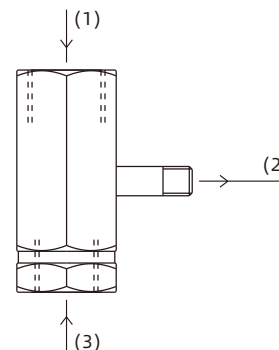

Vacuum Generator

AZK

AZQ

AZX

AZD

AGS

AGP

AGX

AGE

ABM/ABX

ABM/ABX  
Combined Type

AMC

AM/AL/AH

AM/AL  
Combined Type

AMD

AZW

AZR

ABT

ABP

ABQ

AEVC

AZL

ALH

AZH

AZU

ACV

ASBP

**ALS**

ACP

ACPF

ACPS

APB

# ALS Series

## Linear Single Stage Vacuum Generator



### How to order

## ALS - M5F

①

②

Series	Vacuum port connection thread
ALS	M5F - M5×0.8 female thread G1F - G1/8 female thread G2F - G1/4 female thread

### Selection

Model/ Vacuum port connection thread M5F	G1F	G2F
ALS-M5F	ALS-G1F	ALS-G2F

### Technical parameters

Model	Rated air supply pressure bar	Max.vacuum level -kPa	Max.vacuum flow NL/min	Air consumption NL/min	Noise level dB(A)	Weight g
ALS-M5F	5.0	85	14.4	42	80	18
ALS-G1F	5.0	85	14.4	42	80	22
ALS-G2F	5.0	85	14.4	42	80	21

# ALS Series

## Linear Single Stage Vacuum Generator



### Vacuum flow(NL/min) at different vacuum levels(-kPa)

Model	Air supply pressure bar	Air consumption NL/min	0	10	20	30	40	50	60	70	80	Max. vacuum level -kPa
ALS	5.0	42	14.40	13.80	12.00	10.20	7.80	3.60	3.00	1.80	0.24	85

### Evacuation time(s/L) to reach different vacuum levels(-kPa)

Model	Air supply pressure bar	Air consumption NL/min	10	20	30	40	50	60	70	80	Max. vacuum level -kPa
ALS	5.0	42	0.39	0.79	1.34	2.06	3.32	4.62	7.71	13.97	85

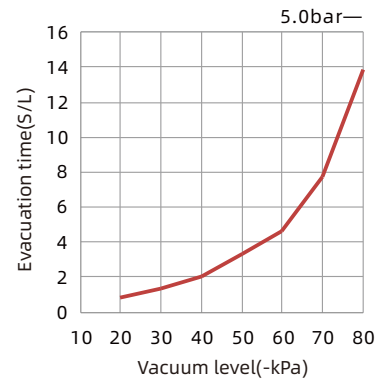
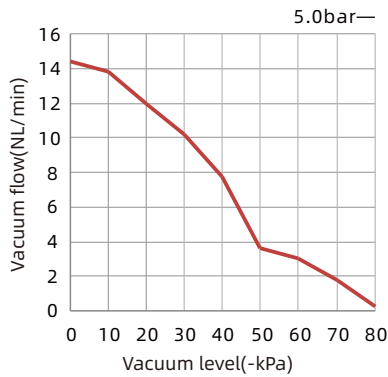

### Dimensions(mm)

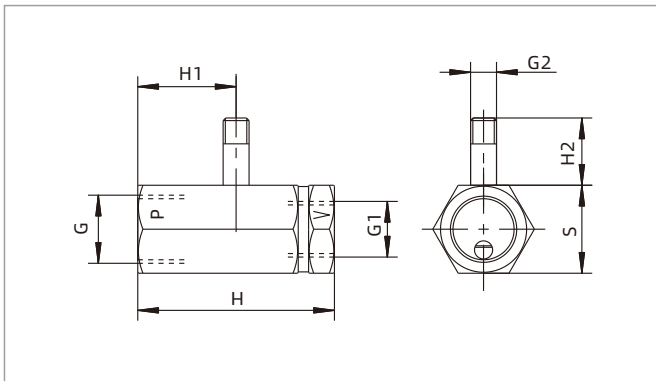

ALS

Model/size	H	H1	H2	G	G1	G2	S
ALS-M5F	30	15	13	G1/4	M5×0.8	M5×0.8	17
ALS-G1F	35	17.5	13	G1/4	G1/8	M5×0.8	17
ALS-G2F	38	19	13	G1/4	G1/4	M5×0.8	17

Vacuum Generator

AZK

AZQ

AZX

AZD

AGS

AGP

AGX

AGE

ABM/ABX

ABM/ABX Combined Type

AMC

AM/AL/AH

AM/AL Combined Type

AMD

AZW

AZR

ABT

ABP

ABQ

AEVC

AZL

ALH

AZH

AZU

ACV

ASBP

**ALS**

ACP

ACPF

ACPS

APB

# ACP Series

## Conveying Vacuum Generator

**AIRBEST**



### Features

- ◇ Straight-through design, extremel large vacuum flow
- ◇ Vacuum flow is adjustable according to the working condition
- ◇ Different diameters are available

### Advantages

- ◇ Handling of workpieces with high permeability, particle, powder, gas and fluid
- ◇ Vacuum flow can be manually adjusted according to the different working conditions



### Applications

- ◇ Handling of loose materials such as textile and paper
- ◇ Conveying of grains such as wheat and corn
- ◇ Conveying of powder particles such as laundry detergent and plastic particles
- ◇ Removal of cutter chips during machining
- ◇ Suction of non-corrosive waste water and waste gas during industrial processing

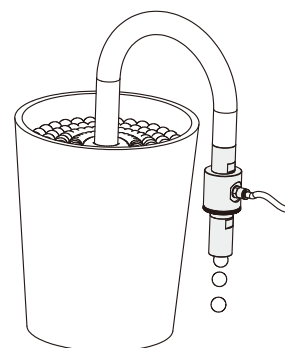

### Structure

- ◇ Straight-through design, can adsorb and transport different materials continuously
- ◇ All ports are connected with female thread

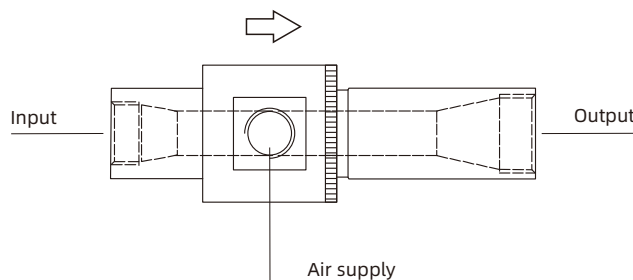

# ACP Series

## Conveying Vacuum Generator

### How to order

ACP 250 S  
 ①      ②      ③

① Series	② Specification	③ Material
ACP	250	Nil - Aluminum alloy
	375	S - Stainless steel
	500	
	750	

### Selection

Model/Material Nil-Aluminum alloy	S - Stainless steel
ACP250	ACP250S
ACP375	ACP375S
ACP500	ACP500S
ACP750	ACP750S

### Technical parameters

Model	Rated air supply pressure bar	Air supply pressure bar	Max. vacuum level -kPa	Max. vacuum flow NL/min	Air consumption NL/min	Working temperature °C	Weight (g)	
							Aluminum alloy	Stainless steel
ACP250	5.5	7	85	280	112~342	-20~80	100	296
ACP375	5.5	7	85	846	176~825	-20~80	286	846
ACP500	5.5	7	70	1,695	341~939	-20~80	401	1,189
ACP750	5.5	7	70	3,390	650~1,813	-20~80	540	1,599

Vacuum Generator

AZK

AZQ

AZX

AZD

AGS

AGP

AGX

AGE

ABM/ABX

ABM/ABX  
Combined Type

AMC

AM/AL/AH

AM/AL  
Combined Type

AMD

AZW

AZR

ABT

ABP

ABQ

AEVC

AZL

ALH

AZH

AZU

ACV

ASBP

ALS

**ACP**

ACPF

ACPS

APB

# ACP Series

## Conveying Vacuum Generator

### Dimensions(mm)

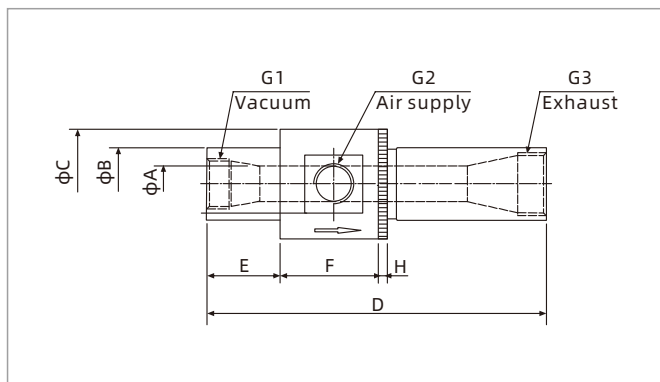

ACP

Model/Size	A	B	C	D	E	F	H	G1	G2	G3
ACP250	6.5	19	32	94~105	22	32	5	G1/4	G1/8	G1/4
ACP375	9.5	25	45	155~165	38	45	5	G3/8	G3/8	G1/2
ACP500	13.0	32	51	155~160	38	51	5	G1/2	G3/8	G3/4
ACP750	19.0	38	58	175~189	38	51	5	G3/4	G1/2	G1"

# ACPF Series

## Conveying Vacuum Generator



### Features

- ◇ Straight-through design, extremely large vacuum flow
- ◇ Different diameters are available, the largest diameter is 38mm

### Advantages

- ◇ Handling of workpieces with high permeability, particle, powder, gas and fluid



### Applications

- ◇ Handling of loose materials such as textile and paper
- ◇ Conveying of grains such as wheat and corn
- ◇ Conveying of powder particles such as laundry detergent and plastic particles
- ◇ Removal of cutter chips during machining
- ◇ Suction of non-corrosive waste water and waste gas during industrial processing

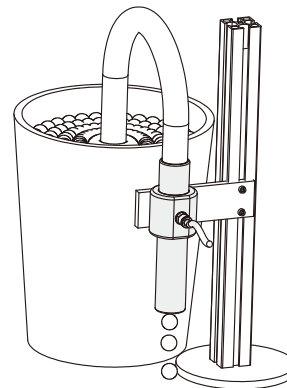

### Structure

- ◇ Straight-through design, can adsorb and transport different materials continuously
- ◇ With mounting threaded hole
- ◇ The ports of ACPF3-3 are threaded connection, and the others are connected by external steel wire hoses

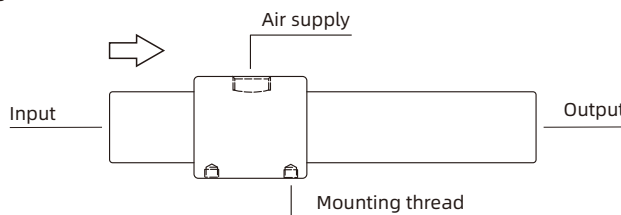

Vacuum Generator

AZK

AZQ

AZX

AZD

AGS

AGP

AGX

AGE

ABM/ABX

ABM/ABX  
Combined Type

AMC

AM/AL/AH

AM/AL  
Combined Type

AMD

AZW

AZR

ABT

ABP

ABQ

AEVC

AZL

ALH

AZH

AZU

ACV

ASBP

ALS

ACP

**ACPF**

ACPS

APB

# ACPF Series

## Conveying Vacuum Generator

### How to order

ACPF 2-3 S  
 ①      ②      ③

① Series	Specification	③ Material
ACPF	2-3	Nil- Aluminum alloy
	3-3	S-Stainless steel
	5-6	
	7-6	
	15-3	
	15-6	

### Selection

Model/Material	
Nil-Aluminum alloy	S - Stainless steel
ACPF2-3	ACPF2-3S
ACPF3-3	ACPF3-3S
ACPF5-6	ACPF5-6S
ACPF7-6	ACPF7-6S
ACPF15-3	ACPF15-3S
ACPF15-6	ACPF15-6S

### Technical parameters

Model	Nozzle diameter mm	Rated air supply pressure bar	Max. vacuum level -kPa	Max. vacuum flow NL/min	Air consumption NL/min		Working temperature °C	Weight(g)	
					2.8bar	5.5bar		Aluminum alloy	Stainless steel
ACPF2-3	6.5	6.0	26.0	295	85	160	-20~80	85	252
ACPF3-3	9.5	6.0	16.0	425	95	170	-20~80	69	205
ACPF5-6	12.5	6.0	35.0	870	395	680	-20~80	170	505
ACPF7-6	19.0	6.0	28.0	1,825	790	1,365	-20~80	388	1,151
ACPF15-3	25.0	6.0	4.4	4,400	405	695	-20~80	519	1,537
ACPF15-6	38.0	6.0	9.0	5,610	790	1,365	-20~80	659	1,953

# ACPF Series

## Conveying Vacuum Generator

### Dimensions(mm)

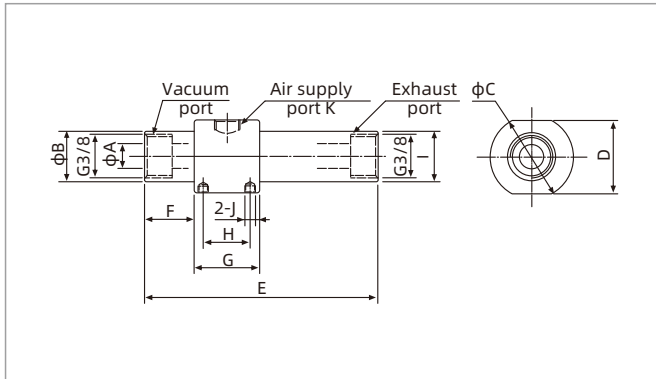

ACPF3-3

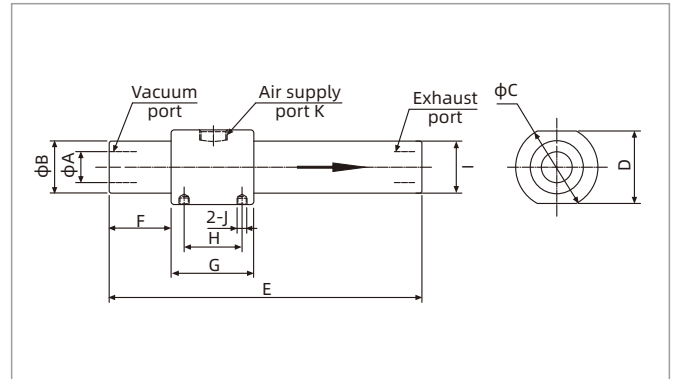

ACPF(Other sizes)

Model/Size	A	B	C	D	E	F	G	H	I	J	K
ACPF2-3	6.5	18.5	32	28	89	19	25	18	19.5	M4×0.7	G1/8
ACPF3-3	9.5	18.5	32	28	89	19	25	18	19.5	M4×0.7	G1/8
ACPF5-6	12.5	24.0	38	34	140	25	32	23	25.0	M4×0.7	G1/4
ACPF7-6	19.0	31.0	50	45	190	38	50	35	33.0	M4×0.7	G3/8
ACPF15-3	25.0	38.0	59	55	198	40	56	40	38.0	M4×0.7	G3/8
ACPF15-6	38.0	49.6	69	65	205	40	60	42	49.6	M4×0.7	G3/8

Vacuum Generator

AZK

AZQ

AZX

AZD

AGS

AGP

AGX

AGE

ABM/ABX

ABM/ABX  
Combined Type

AMC

AM/AL/AH

AM/AL  
Combined Type

AMD

AZW

AZR

ABT

ABP

ABQ

AEVC

AZL

ALH

AZH

AZU

ACV

ASBP

ALS

ACP

**ACPF**

ACPS

APB

# ACPS Series

## Conveying Vacuum Generator

**AIRBEST**



BIOPHARMING



FOOD



PACKAGING



### Features

- ◇ Straight-through design, extremely large vacuum flow
- ◇ Different diameters are available

### Advantages

- ◇ Handling of workpieces with high permeability, particle, powder, gas and fluid



### Applications

- ◇ Handling of loose materials such as textile and paper
- ◇ Conveying of grains such as wheat and corn
- ◇ Conveying of powder particles such as laundry detergent and plastic particles
- ◇ Removal of cutter chips during machining
- ◇ Suction of non-corrosive waste water and waste gas during industrial processing

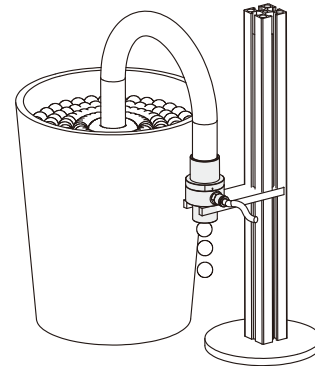

### Structure

- ◇ Straight-through design, can adsorb and transport different materials continuously
- ◇ Compressed air goes through the lateral annular gap

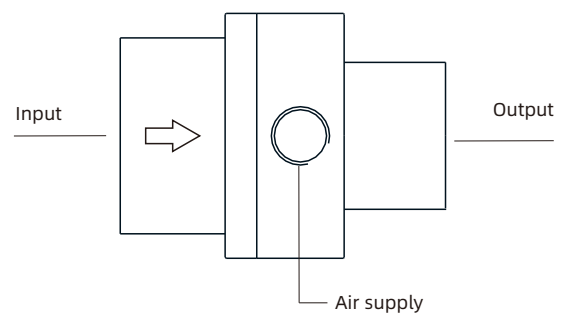

# ACPS Series

## Conveying Vacuum Generator

### How to order

## ACPS 10

① ②

① Series	② Nozzle diameter
ACPS	10 - $\phi$ 10mm 20 - $\phi$ 20mm 40 - $\phi$ 40mm 75 - $\phi$ 75mm

### Selection

Model/Nozzle diameter	10	20	40	75
ACPS□	ACPS10	ACPS20	ACPS40	ACPS75

### Technical parameters

Model	Nozzle diameter mm	Rated air supply pressure bar	Max. vacuum level -kPa	Max. vacuum flow NL/min	Air consumption NL/min	Working temperature °C	Weight g
ACPS10	10	5.0	12	550	140	-20~80	77
ACPS20	20	5.0	4	1,375	265	-20~80	189
ACPS40	40	5.0	2	2,250	470	-20~80	522
ACPS75	75	5.0	1	8,640	876	-20~80	2,308

### Dimensions(mm)

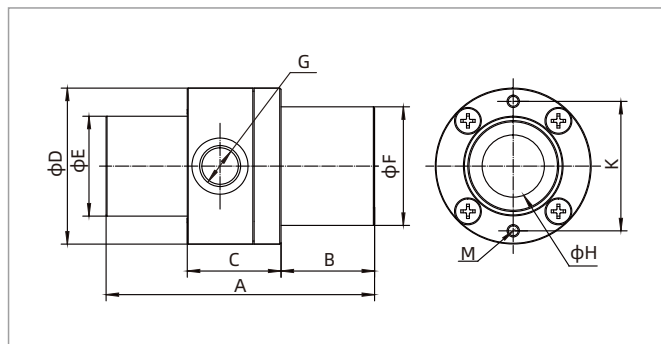

ACPS

Model/Size	A	B	C	D	E	F	G	H	K	M
ACPS10	70	23	21	37	19	19	G1/8	10	29.0	2-M4×0.7
ACPS20	86	30	30	50	32	38	G1/4	20	41.5	2-M4×0.7
ACPS40	94	30	34	84	52	75	G3/8	40	72.0	2-M4×0.7
ACPS75	180	34	65	140	100	125	G1/2	75	126.0	2-M6×1

AZK

AZQ

AZX

AZD

AGS

AGP

AGX

AGE

ABM/ABX

ABM/ABX  
Combined Type

AMC

AM/AL/AH

AM/AL  
Combined Type

AMD

AZW

AZR

ABT

ABP

ABQ

AEVC

AZL

ALH

AZH

AZU

ACV

ASBP

ALS

ACP

ACPF

ACPS

APB

# APB Series

## High Pressure Vacuum Blower



PACKAGING



WOOD



COMPOSITE MATERIAL

### Features

- ◇ Extremely high suction capacity
- ◇ The housing and impeller are made of high strength die-casting aluminum alloy
- ◇ Available in various suction capacity

### Advantages

- ◇ Fast and reliable handling of porous materials
- ◇ Low noise and high suction capacity
- ◇ It can be precisely selected according to the actual working conditions



### Applications

- ◇ Handling of cartons, wood, foam materials, heat insulating materials and other extremely porous materials
- ◇ Extremely high suction flow to compensate for leakage easily

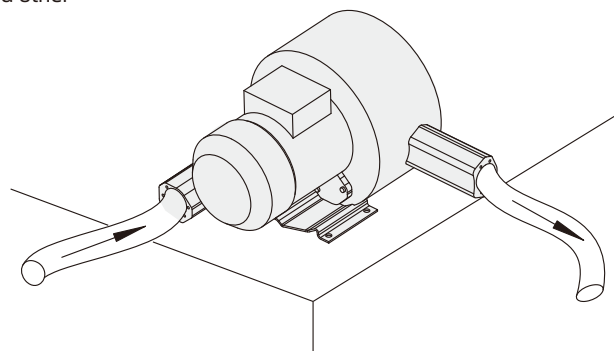

### Structure

- ◇ (1) Air supply port
- ◇ (2) Side channel
- ◇ (3) Impeller
- ◇ (4) Exhaust port

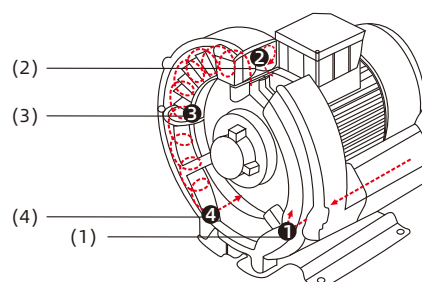

# APB Series

## High Pressure Vacuum Blower

### How to order

APB - 420  
 ①                      ②

② Series	① Specifications
APB	420 520 620 720 820 920

### Selection

Model	Model
APB-420	APB-720
APB-520	APB-820
APB-620	APB-920

### Technical parameters

Model	Motor (50HZ)			Max. flow m <sup>3</sup> /h	Max. vacuum level -kPa	Max. pressure mbar	Noise level dB(A)	Protection grade IP	Weight kg
	Rated power KW	Input voltage V	Rated current A						
APB-420	1.5	220-240△/345-415	7.5△/4.3Y	87	48	450	61	IP55	33
APB-520	2.2	220-240△/345-415	11.4△/6.6Y	120	47	460	64	IP55	40
APB-620	3.2	220-240△/345-415	13.0△/7.5Y	165	46	500	67	IP55	48
APB-720	5.5	345-415△/600-720	13.0△/7.7Y	320	44	500	73	IP55	66
APB-820	7.5	345-415△/600-720	13.3△/7.7Y	520	40	400	74	IP55	86
APB-920	16.5	345-415△/600-720	35.0△/20.0Y	1,110	41	370	74	IP55	197

### Dimensions(mm)

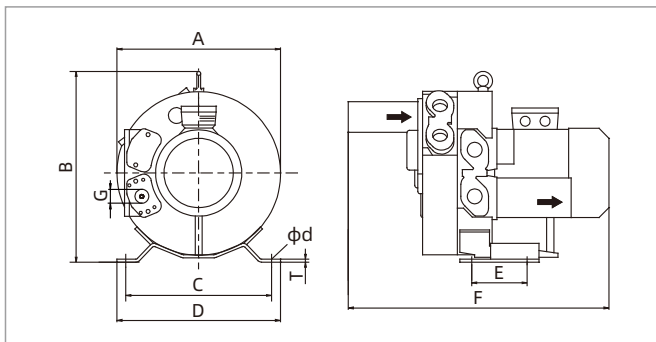

APB-420~620

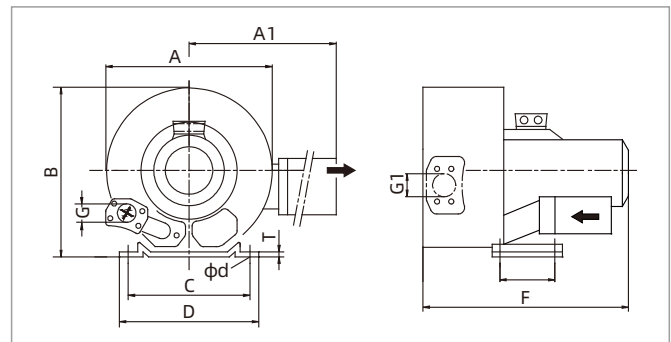

APB-720

AZK

AZQ

AZX

AZD

AGS

AGP

AGX

AGE

ABM/ABX

ABM/ABX  
Combined Type

AMC

AM/AL/AH

AM/AL  
Combined Type

AMD

AZW

AZR

ABT

ABP

ABQ

AEVC

AZL

ALH

AZH

AZU

ACV

ASBP

ALS

ACP

ACPF

ACPS

APB

# APB Series

## High Pressure Vacuum Blower

### Dimensions(mm)

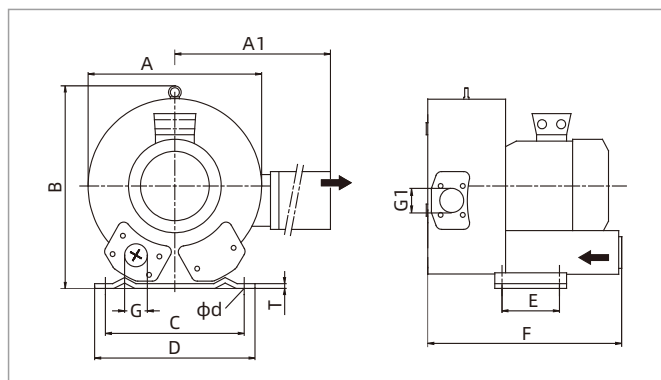

APB-820

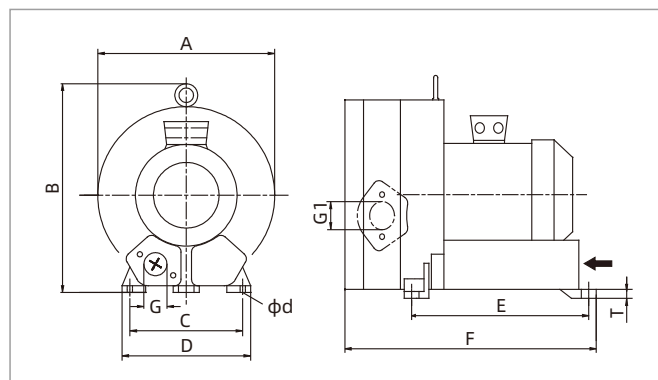

APB-920

Model/Size	A	A1	B	C	D	$\phi d$	E	F	T	G	G1
APB-420	363	-	414	315	350	14	130	529	4	G1"1/4depth18	-
APB-520	387	-	435	328	363	14	130	549	5	G1"1/4depth18	-
APB-620	442	-	495	372	406	14	152	578	5	G1"1/4depth18	-
APB-720	426	426	410	290	325	15	140	571	4.5	$\phi 55$	
APB-820	500	549	509	356	545	15	170	589	6	G2"1/2	
APB-920	615	-	623	360	415	15	533	786	21	$\phi 100$	

### Safety Information

- ◇ Remarks: If this product has the following applications: logistics and transportation, consumer goods industry, agriculture, construction industry, comprehensive trade, etc. This type of equipment usually includes exposed parts. They are very dangerous since they are moving parts or rotating parts in many cases during working process. Unauthorized removal of protective covers, improper use, improper operation or insufficient maintenance may cause serious personal injury or equipment failure.
- ◇ The staff responsible for safety must ensure: Only qualified personnel can operate such equipment.  
Qualified personnel are already fully familiar with the operation manual when operating these equipment and can operate according to the installation manual systematically.  
Unqualified personnel are not allowed to operate such equipment.
- ◇ Qualified personnel: the personnel authorized by the person in charge of plant safety.  
They complete a certain necessary work based on their own experience and training, knowledge of relevant standards, and ability to prevent accidents, while being aware of potential dangers and take necessary measures.
- ◇ DIN VDE 0105 or IGC 364 stipulates that unqualified personnel shall not be engaged in electrical equipment work.  
Product manuals or catalogue cannot contain all the detailed information, especially it is impossible to cover every possible safety, operation and maintenance method. Therefore, these operating manuals only include the necessary information for qualified personnel to operate the equipment correctly. If the detailed parameters of the product are lacking, please contact us for more information.

# C Vacuum Suction Cups

# Suction cups

## Products overview

### Suction cups

#### 155 SZ Series

##### Standard Suction Cup

- ◇ Diameter: 2-50mm
- ◇ Material: N WS CN CS HP



ELECTRONICS



#### 192 SOFA Series

##### Oval Flat Suction Cup

- ◇ Size: 6×18mm
- ◇ Material: N WS



ELECTRONICS



#### 163 SPH Series

##### Conductive/Mark-free Suction Cup

- ◇ Diameter: 4-16mm
- ◇ Material: CH



ELECTRONICS



#### 193 STP Series

##### Ultra-thin Flower-Shaped Suction Cup

- ◇ Diameter: 35-60mm
- ◇ Material: S WS



PACKAGING HIGH SEALING



#### 169 SP3 Series

##### Suction Cup

- ◇ Diameter: 1.5-16mm
- ◇ Material: N WS CN CS HP



ELECTRONICS



#### 195 SFT Series

##### Flat Suction Cup Special for Plastic Film and Paper

- ◇ Diameter: 15-40mm
- ◇ Material: WS HD NR



PAPER



PLASTIC BAG



SOLAR



ANTI-DEFORMATION



#### 183 SUF Series

##### Small Flat Suction Cup

- ◇ Diameter: 3.5-5.5mm
- ◇ Material: N S



ELECTRONICS



#### 198 SFA Series

##### Flat Ultra-thin Lip Suction Cup

- ◇ Diameter: 20-50mm
- ◇ Material: S



PLASTIC BAG



HIGH SEALING



#### 184 SAN Series

##### Nozzle Type Suction Cup

- ◇ Diameter: 0.8-1.1mm
- ◇ Material: N WS CN CS



ELECTRONICS



#### 201 SBT Series

##### Bellows Suction Cup Special for Thin Workpieces

- ◇ Diameter: 16mm
- ◇ Material: N WS



PLASTIC BAG



ANTI-DEFORMATION



#### 185 SAO Series

##### Oval Flat Suction Cup

- ◇ Size: 3.5×7-8×30mm
- ◇ Material: N WS CN CS



ELECTRONICS



#### 202 SBL Series

##### 4.5 Bellows Suction Cup

- ◇ Diameter: 15-50mm
- ◇ Material: N S WS



FOOD PACKAGING



PLASTIC BAG



FDA



# Suction cups

## Products overview

### Suction cups

#### 205 SBLP Series

RoHS

##### Multiple Bellows Suction Cup Special for Soft Packing Bags

- ◇ Diameter: 30-50mm
- ◇ Material: S



#### 220 SGP Series

RoHS

##### PU Bellows Suction Cup

- ◇ Diameter: 25-55mm
- ◇ Material: U UD



#### 207 SBS Series

RoHS

##### Suction Cup Special for Spherical Objects

- ◇ Diameter: 30-35mm
- ◇ Material: S WS WSA



#### 223 SBOF Series

RoHS

##### 2.5 Bellows Oval Suction Cup

- ◇ Size: 35×28 45×28mm
- ◇ Material: V



#### 209 SFP Series

RoHS

##### PU Flat Suction Cup

- ◇ Diameter: 20-40mm
- ◇ Material: U UY



#### 226 STC Series

RoHS

##### 1.5 Bellows Suction Cup Special for Metal Sheet

- ◇ Diameter: 22-125mm
- ◇ Material: N HK HD



#### 212 SBP Series

RoHS

##### PU Bellows Suction Cup

- ◇ Diameter: 10-70mm
- ◇ Material: U UY UD



#### 230 SFF Series

RoHS

##### Flat Suction Cup Special for Metal Sheet

- ◇ Diameter: 30-125mm
- ◇ Material: N NG HK HD



#### 216 SXP Series

RoHS

##### PU Bellows Suction Cup

- ◇ Diameter: 20-70mm
- ◇ Material: U UG UD



#### 234 SOB Series

RoHS

##### Oval Bellows Suction Cup Special for Metal Sheet

- ◇ Size: 30×60-70×140mm
- ◇ Material: N HK HD



# Suction cups

## Products overview

### Suction cups

#### 237 SOF Series

RoHS

##### Oval Flat Suction Cup Special for Metal Sheet

◇ Size: 16×50-70×140mm

◇ Material: N NG HK HD



#### 254 SDM Series

RoHS

##### Flat Suction Cup Special for Metal Sheet

◇ Diameter: 100mm

◇ Material: U



#### 241 SOG Series

RoHS

##### Oval Flat Suction Cup Special for Cylindrical Objects

◇ Size: 15×40mm 35×100mm

◇ Material: N

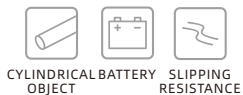

#### 256 SFU Series

RoHS

##### Big Flat Suction Cup

◇ Diameter: 100-400mm

◇ Material: N WS



#### 244 SFM Series

RoHS

##### Flat Suction Cup Special for Oily Metal Sheet

◇ Diameter: 30-120mm

◇ Material: U



#### 260 SFK Series

RoHS

##### Flat Suction Cup Special for Rough Surface Objects

◇ Diameter: 110-250mm

◇ Material: E

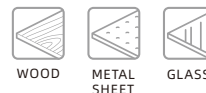

#### 248 SOM Series

RoHS

##### Oval Flat Suction Cup Special for Long and Narrow Objects

◇ Size: 20×60-40×100mm

◇ Material: U



#### 263 SHT Series

RoHS

##### High Temperature Suction Cup

◇ Diameter: 35-90mm

◇ Material: --



#### 251 SBF Series

RoHS

##### 1.5 Bellows Suction Cup Special for Metal Sheet

◇ Diameter: 30-100mm

◇ Material: U



#### 265 SDL Series

RoHS

##### Annular Suction Cup

◇ Diameter: 100mm

◇ Material: N



# Suction cups

## Products overview

### Suction cups

#### 266 SFG Series

##### Flat Suction Cup for Glass Industry

◇ Diameter: 125-400mm

◇ Material: E HD



GLASS



SLIPPING RESISTANCE



HIGH SEALING



#### 283 SF Series

##### Universal Flat Suction Cup

◇ Diameter: 15-300mm

◇ Material: N S WS CS



UNIVERSAL



#### 269 SFGT Series

##### Big Flat Suction Cup

◇ Diameter: 65-160mm

◇ Material: ws



METAL SHEET



GLASS



#### 289 SU Series

##### Universal Flat Suction Cup

◇ Diameter: 6-80mm

◇ Material: N S WS CS



UNIVERSAL



#### 271 SFD Series

##### Flat Suction Cup for Wood Industry

◇ Diameter: 40-70mm

◇ Material: N WS NR



WOOD



#### 293 SP2F Series

##### Universal Flat Suction Cup

◇ Diameter: 10-15mm

◇ Material: N WS CN CS



PAPER



ANTI-DEFORMATION



#### 273 SB Series

##### Universal Bellows Suction Cup

◇ Diameter: 5-150mm

◇ Material: N S WS CS



UNIVERSAL



#### 300 SPA Series

##### Thin Lip Flat Suction Cup

◇ Diameter: 10-50mm

◇ Material: N WS CN CS



PAPER



ANTI-DEFORMATION



#### 278 SBA Series

##### 1.5 Bellows Suction Cup

◇ Diameter: 6-78mm

◇ Material: N WS HD NR



UNIVERSAL



#### 309 SPD Series

##### Thin Lip Flat Suction Cup

◇ Diameter: 10-15mm

◇ Material: N WS



PAPER



# Suction cups

## Products overview

### Suction cups

#### 311 SPF Series

##### Flat Suction Cup

- ◇ Diameter: 2-200mm
- ◇ Material: N WS CN CS



UNIVERSAL



RoHS

#### 348 SHB Series

##### Heavy Load Bellows Suction Cup

- ◇ Diameter: 40-125mm
- ◇ Material: N WS



METAL SHEET



WOOD



HEAVY LOAD



CURVED SURFACE



RoHS

#### 323 SPC Series

##### Bellows Suction Cup

- ◇ Diameter: 3-90mm
- ◇ Material: N WS CN CS



PACKAGING



PLASTIC



ELECTRONICS



RoHS

#### 355 SBB Series

##### 1.5 Bellows Big Suction Cup

- ◇ Diameter: 200-300mm
- ◇ Material: N



HEAVY LOAD



RoHS

#### 329 SPJ Series

##### Bellows Suction Cup

- ◇ Diameter: 4-80mm
- ◇ Material: N WS CN CS HP



PACKAGING



PLASTIC



RoHS

#### 357 SOP Series

##### Circular Foam Rubber Cup

- ◇ Diameter: 40-220mm
- ◇ Material: NF OF



STONE



ROUGH SURFACE



RoHS

#### 338 SPU Series

##### Swivel Flat Suction Cup

- ◇ Diameter: 10-100mm
- ◇ Material: N WS



METAL SHEET



WOOD



CURVED SURFACE



RoHS

#### 359 SNP Series

##### Rectangular Foam Rubber Cup

- ◇ Size: 50×135-140×290mm
- ◇ Material: NF OF



STONE



ROUGH SURFACE



RoHS

#### 341 SH Series

##### Heavy Load Flat Suction Cup

- ◇ Diameter: 40-125mm
- ◇ Material: N WS



METAL SHEET



WOOD



HEAVY LOAD



RoHS

# SZ Series

## Standard Suction Cup



ELECTRONICS



### Features

- ◇ Available in various shapes: U type, C type, B type and D type
- ◇ Simple structure
- ◇ Conductive material available
- ◇ Available in various sizes

### Advantages

- ◇ Small size and light weight
- ◇ Suitable for workpieces of various sizes and shapes



B-Bellows type

D-Deep type



U-Flat type

C-Flat type with ribs

### Applications

- ◇ U type suitable for workpieces with even surface and without deformation
- ◇ C type suitable for easily deformed workpieces
- ◇ B type suitable for workpieces with inclined surface
- ◇ D type suitable for spherical objects
- ◇ Suitable for handling of paper box, small sized semiconductor, spherical objects and food, ect.
- ◇ Conductive material suitable for 3C industry

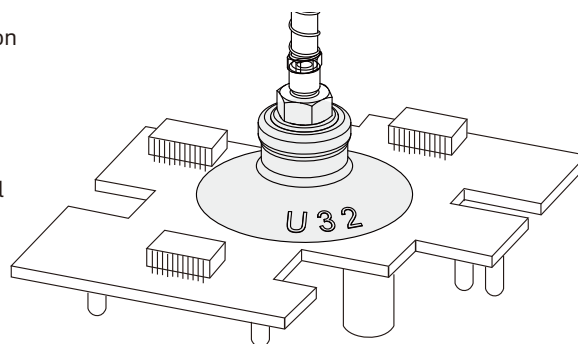

### Structure

- ◇ Split structure for easy replacement of wearing parts

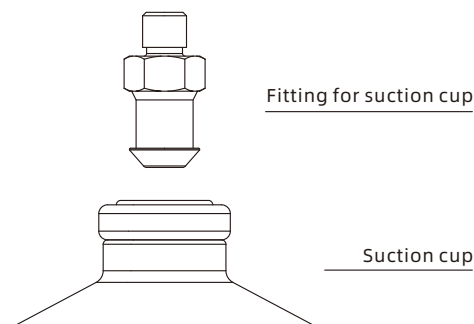

SZ

SPH

SP3

SUF

SAN

SAO

SOFA

STP

SFT

SFA

SBT

SBL

SBLP

SBS

SFP

SBP

SXP

SGP

SBOF

STC

SFF

SOB

SOF

SOG

SFM

SOM

SBF

SDM

SFU

SFK

SHT

SDL

SFG

SFGT

SFD

SB

SBA

SF

SU

SP2F

SPA

SPD

SPF

SPC

SPJ

SPU

SH

SHB

SBB

SOP

SNP

# SZ Series

## Standard Suction Cup

### How to order

**SZ B 10 N**  
 ①    ②    ③    ④

① Series	② Suction cup type	③ Diameter		④ Material & Hardness	
SZ	U - Flat	2 - φ2mm	16 - φ16mm	N - NBR	50
	C - Flat with ribs	4 - φ4mm	20 - φ20mm	WS - White silicone	45
	B - 1.5 bellows	6 - φ6mm	25 - φ25mm	CN - Conductive NBR	55
	D - Deep	8 - φ8mm	32 - φ32mm	CS - Conductive silicone	55
		10 - φ10mm	40 - φ40mm	HP - Mark free rubber	50
		13 - φ13mm	50 - φ50mm		

◇ Note: HP material is not for all sizes. Please contact AIRBEST if need

### Selection

Diameter of suction cup	Suction cup type			
	U - Flat	C - Flat with ribs	B - 1.5 Bellows	D - Deep
φ2	SZU2□	-	-	-
φ4	SZU4□	-	-	-
φ6	SZU6□	-	SZB6□	-
φ8	SZU8□	-	SZB8□	-
φ10	SZU10□	SZC10□	SZB10□	SZD10□
φ13	SZU13□	SZC13□	SZB13□	-
φ16	SZU16□	SZC16□	SZB16□	SZD16□
φ20	SZU20□	SZC20□	SZB20□	-
φ25	SZU25□	SZC25□	SZB25□	SZD25□
φ32	SZU32□	SZC32□	SZB32□	-
φ40	SZU40□	SZC40□	SZB40□	SZD40□
φ50	SZU50□	SZC50□	SZB50□	-

# SZ Series

## Standard Suction Cup

### Technical parameters

Diameter of suction cup	Pull-out force N	Inner volume(cm <sup>3</sup> )				Recommended hose dia. mm	MPQ pcs
		SZU	SZC	SZB	SZD		
φ2	0.15	< 0.1	-	-	-	4	10
φ4	0.6	< 0.1	-	-	-	4	10
φ6	1.2	< 0.1	-	< 0.1	-	4	10
φ8	2.2	< 0.1	-	< 0.1	-	4	10
φ10	3.5	0.15	0.15	0.3	0.3	6	10
φ13	6	0.2	0.2	0.9	-	6	10
φ16	9.6	0.3	0.3	1.3	0.6	6	10
φ20	15	0.6	0.6	2.2	-	6	5
φ25	24	0.9	0.9	3.3	1.5	6	5
φ32	38	1.6	1.6	7.2	-	6	5
φ40	60	3.5	3.5	15	9	6	1
φ50	92	6	6	25	-	6	1

◇ Note: Testing vacuum level -60kPa, workpiece with smooth and clean surface. The data of pull-out force as above are figured out without considering safety factor. The data may be different according to different workpiece surfaces. Recommend the length of vacuum hose to be as short as possible, max 2m.

### Dimensions(mm)

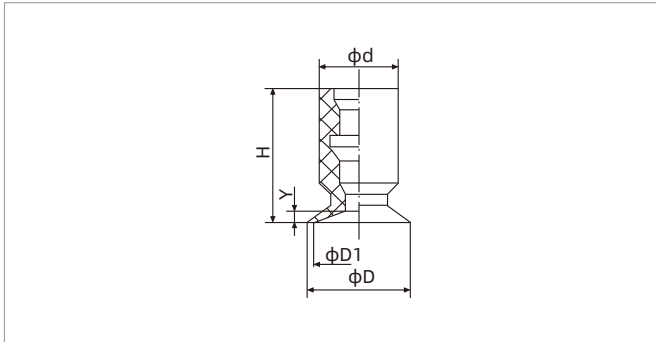

SZU2-8

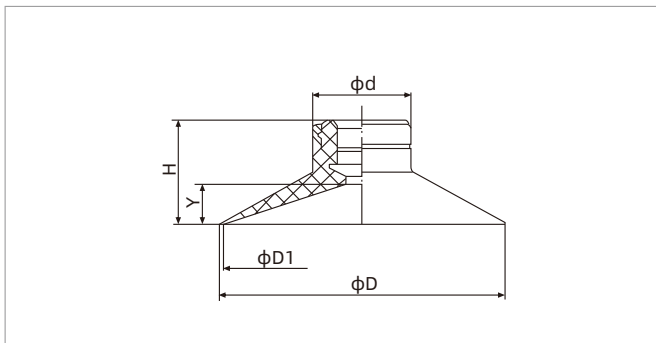

SZU10-50

Model/Size	D	D1	H	d	Y	Weight g
SZU2□	2.6	2	12	7	0.5	0.3
SZU4□	4.8	4	12	7	0.8	0.3
SZU6□	7	6	12	7	0.8	0.4
SZU8□	9	8	12	7	1	0.4

Model/Size	D	D1	H	d	Y	Weight g
SZU10□	12	10	12	13	3	0.8
SZU13□	15	13	12	13	3	0.8
SZU16□	18	16	12.5	13	3.5	0.9
SZU20□	23	20	14	15	4	1.6
SZU25□	28	25	14	15	4	1.8
SZU32□	35	32	14.5	15	4.5	2.3
SZU40□	43	40	18.5	18	6.5	5.5
SZU50□	53	50	19.5	18	7.5	6.9

SZ

SPH

SP3

SUF

SAN

SAO

SOFA

STP

SFT

SFA

SBT

SBL

SBLP

SBS

SFP

SBP

SXP

SGP

SBOF

STC

SFF

SOB

SOF

SOG

SFM

SOM

SBF

SDM

SFU

SFK

SHT

SDL

SFG

SFGT

SFD

SB

SBA

SF

SU

SP2F

SPA

SPD

SPF

SPC

SPJ

SPU

SH

SHB

SBB

SOP

SNP

# SZ Series

## Standard Suction Cup

### Dimensions(mm)

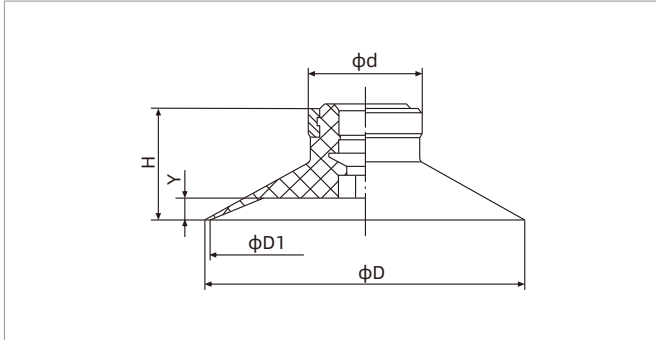

SZC10-50

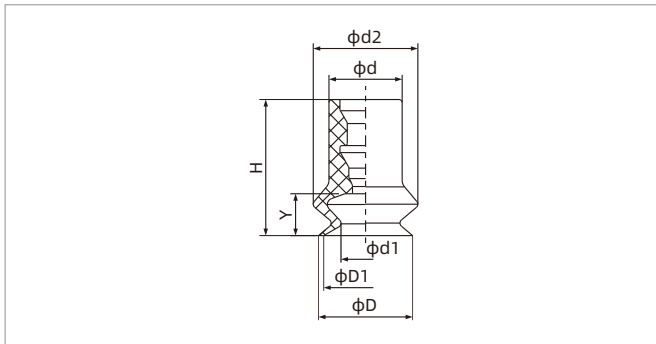

SZB6-8

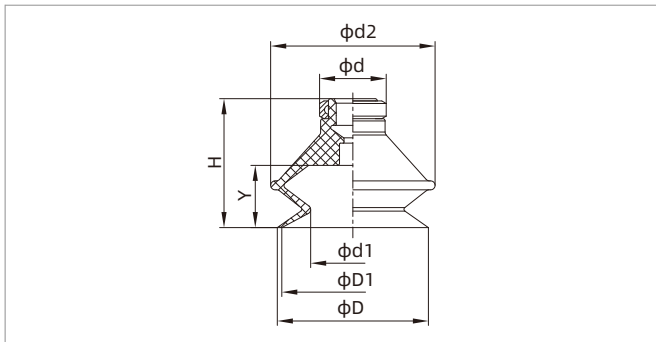

SZB10-50

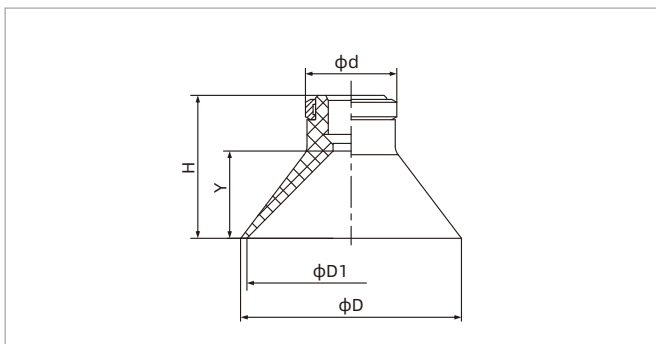

SZD10-40

◇ Note: The dimensional tolerance conforms to GBT3672.1-2002-1 M3 rubber product dimensional tolerance standard

Model/Size	D	D1	H	d	Y	Weight g
SZC10□	12	10	12	13	1.7	0.8
SZC13□	15	13	12	13	1.8	1.0
SZC16□	18	16	12.5	13	1.2	0.9
SZC20□	23	20	14	15	1.7	1.6
SZC25□	28	25	14	15	1.8	2.1
SZC32□	35	32	14.5	15	2.3	2.4
SZC40□	43	40	18.5	18	3.3	5.5
SZC50□	53	50	19.5	18	3.8	7.3

Model/Size	D	D1	H	d	d1	d2	Y	Buffer stroke	Weight g
SZB6□	7	6	13	7	3.3	9.1	4	4	0.4
SZB8□	9	8	13	7	4.7	10.1	4	4	0.4

Model/Size	D	D1	H	d	d1	d2	Y	Buffer stroke	Weight g
SZB10□	12	10	16	13	5.5	13.8	5.5	5	1.1
SZB13□	15	13	18.5	13	8.7	19	7.5	7	1.7
SZB16□	18	16	20	13	9.9	21	8.5	7	2.1
SZB20□	22	20	23.5	15	12.4	25	10.5	8.5	2.9
SZB25□	27	25	24	15	15.6	28	10.5	8.5	3.9
SZB32□	34	32	29	15	18.9	37	14	11	6.7
SZB40□	43	40	34	18	24.4	48	16	13	13.3
SZB50□	53	50	38	18	32.4	57	19	17	18.8

Model/Size	D	D1	H	d	Y	Weight g
SZD10□	12	10	15	13	6	1.0
SZD16□	18	16	16	13	7	1.2
SZD25□	28	25	20	15	10	1.8
SZD40□	43.5	40	28	18	17	5.9

# SZ Series

## Suction Cup with Locking Fitting

### Structure

- ◇ Consisting of replacement suction cup and locking fitting
- ◇ Plug-in fitting for suction cup
- ◇ Vertical vacuum port, male and female thread for mounting
- ◇ Lateral vacuum port, male and female thread for mounting

In the same series, replacement suction cup and locking fitting can be combined as required

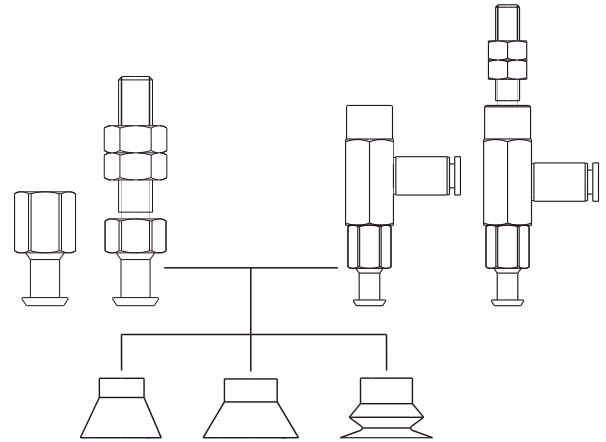

### How to order

## SZU10N - LA6 - M5M

①                      ②                      ③

① Model	② Vacuum port direction	③ Mounting thread
SZU10N	Nil - Vertical	M5M - M5×0.8 male thread
SZC	LA4 - Lateral, one-touch fitting φ4 hose	M6M - M6×1 male thread
SZB	LA6 - Lateral, one-touch fitting φ6 hose	M8M - M8×1 male thread
SZD		M5F - M5×0.8 female thread
		M8F - M8×1.25 female thread

◇ Please refer to page 156 for suction cup selection

### Selection

Diameter of suction cup	Vacuum port direction			Mounting thread				
	Nil	LA4	LA6	M5M	M6M	M8M	M5F	M8F
2-8	●	●	●	●	-	-	●	-
10-16	●	●	●	●	-	-	●	-
20-32	●	●	●	-	●	-	●	-
40-50	●	-	●	-	-	●	-	●

◇ Note: "●" default, in stock, "-" unavailable

SZ

SPH

SP3

SUF

SAN

SAO

SOFA

STP

SFT

SFA

SBT

SBL

SBLP

SBS

SFP

SBP

SXP

SGP

SBOF

STC

SFF

SOB

SOE

SOG

SFM

SOM

SBF

SDM

SFU

SFK

SHT

SDL

SFG

SFGT

SFD

SB

SBA

SF

SU

SP2F

SPA

SPD

SPF

SPC

SPJ

SPU

SH

SHB

SBB

SOP

SNP

# SZ Series

## Suction Cup with Locking Fitting



### Dimensions(mm)

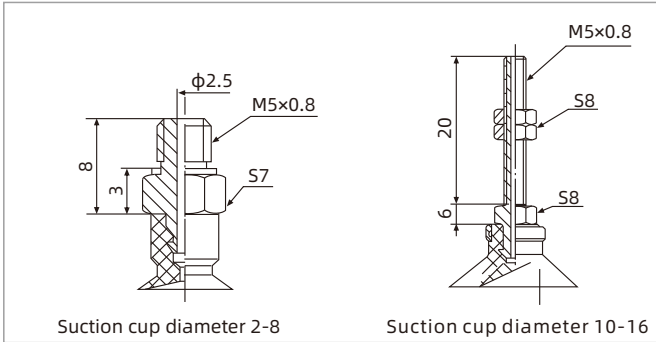

Vertical-Male thread connection

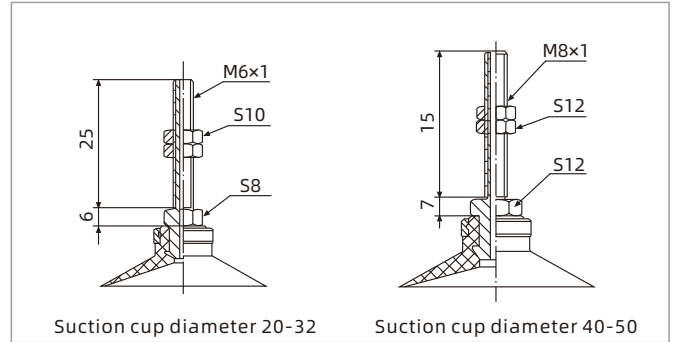

Vertical-Male thread connection

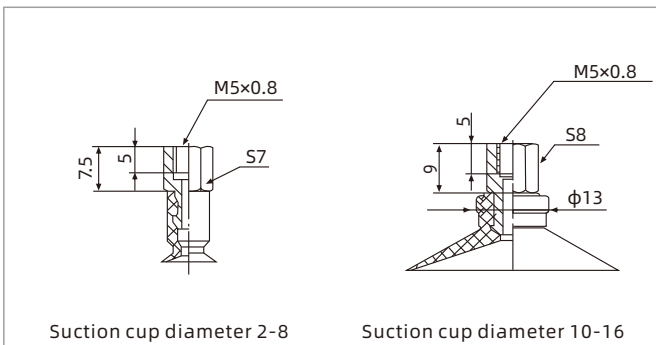

Vertical-Female thread connection

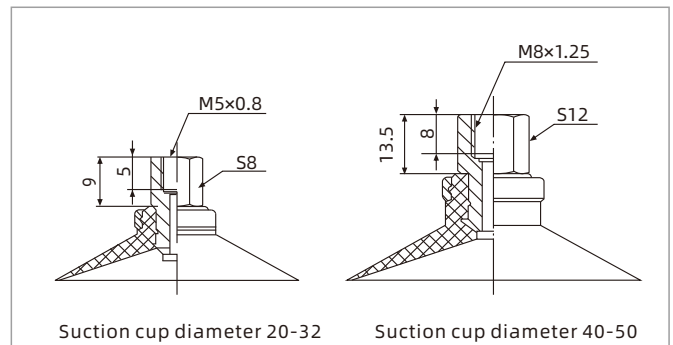

Vertical-Female thread connection

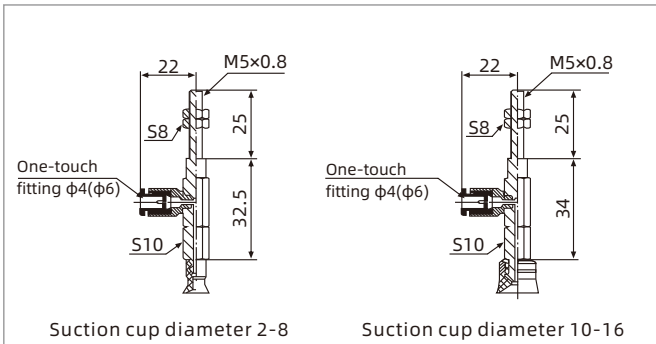

Lateral-Male thread connection

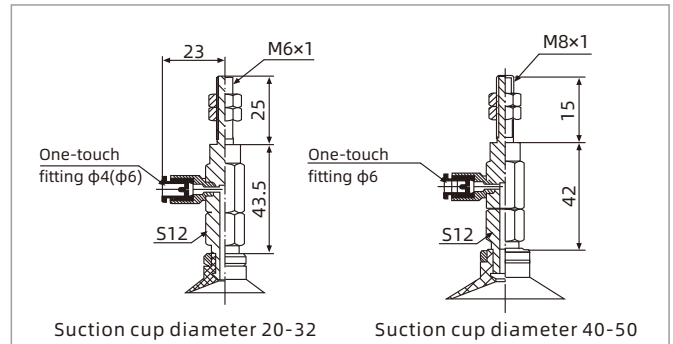

Lateral-Male thread connection

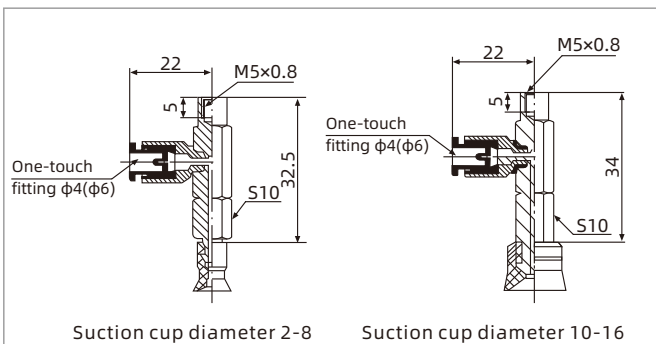

Lateral-Female thread connection

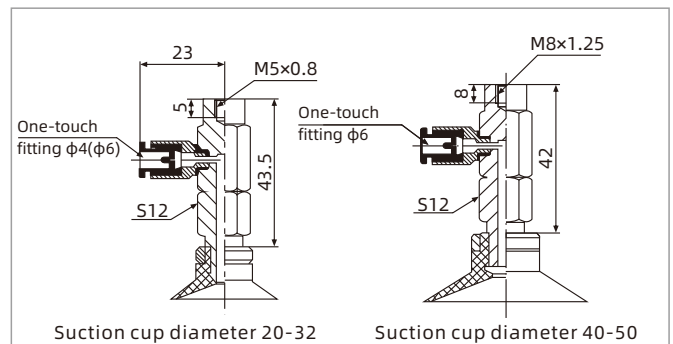

Lateral-Female thread connection

# SZ Series

## Suction Cup with Level Compensator

### Structure

- ◇ Consisting of replacement suction cup(3) and level compensator
- ◇ Plug-in fitting for suction cup
- ◇ Vertical vacuum port(1), male thread for mounting
- ◇ Lateral vacuum port(2), male thread for mounting

In the same series, replacement suction cup and locking fitting can be combined as required

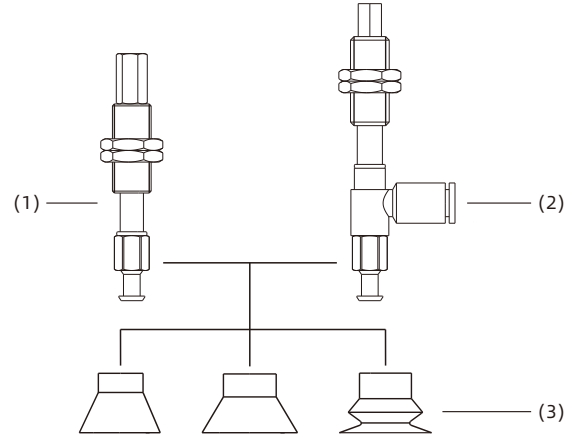

### How to order

**SZU10N - E I 10 R A6 - M10**

①                    ②   ③   ④   ⑤   ⑥                    ⑦

① Model	② Level compensator type	③ Buffer type	④ Buffer stroke	⑤ Rotary type	⑥ Vacuum port connection	⑦ Mounting thread
<b>SZU10N</b>	E - PSPE Series	I - Internal spring	6    20	Nil - Vertical rotating	Nil - M5x0.8 female thread	M8 - M8x1
<b>SZC</b>			10   30	R - Vertical non-rotating	A4 - one-touch fitting φ4 hose	M10 - M10x1
<b>SZB</b>			15   40	L - Lateral rotating	A6 - one-touch fitting φ6 hose	M14 - M14x1
<b>SZD</b>			25   50	B - Lateral non-rotating	B4 - Pagoda fitting φ4 hose B6 - Pagoda fitting φ6 hose	

◇ Please refer to page 156 for suction cup selection

### Selection

Diameter of suction cup	Buffer stroke	Rotary type				Vacuum port connection					Mounting thread
		Nil	R	L	B	Nil	A4	A6	B4	B6	
2-8	6, 10, 15, 25	●	●	●	●	●	●	●	●	-	M8
10-32	10, 20, 30, 40, 50	●	●	●	●	●	●	●	-	●	M10
40-50	10, 20, 30, 50	●	-	-	-	●	-	-	-	-	M14

◇ Note: "●" default, in stock, "-" unavailable

SZ

SPH

SP3

SUF

SAN

SAO

SOFA

STP

SFT

SFA

SBT

SBL

SBLP

SBS

SFP

SBP

SXP

SGP

SBOF

STC

SFF

SOB

SOE

SOG

SFM

SOM

SBF

SDM

SFU

SFK

SHT

SDL

SFG

SFGT

SFD

SB

SBA

SF

SU

SP2F

SPA

SPD

SPF

SPC

SPJ

SPU

SH

SHB

SBB

SOP

SNP

# SZ Series

## Suction Cup with Level Compensator

### Dimensions(mm)

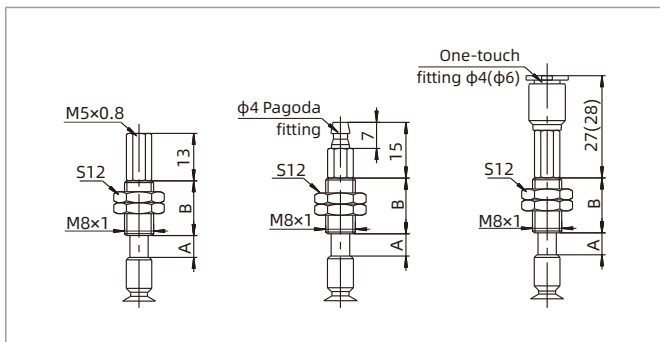

Vertical direction Suction cup diameter 2-8

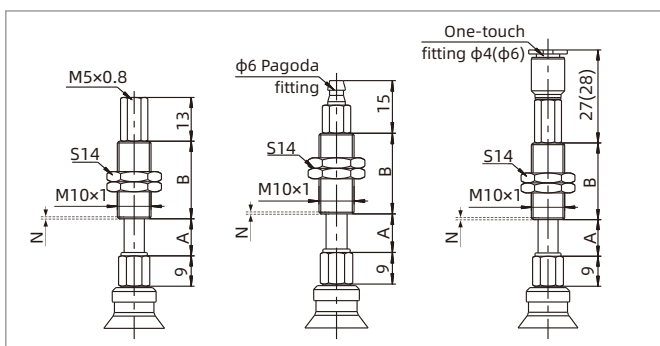

Vertical direction Suction cup diameter 10-32

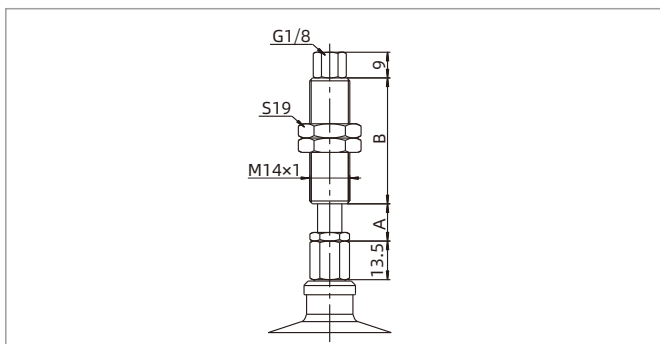

Vertical direction Suction cup diameter 40-50

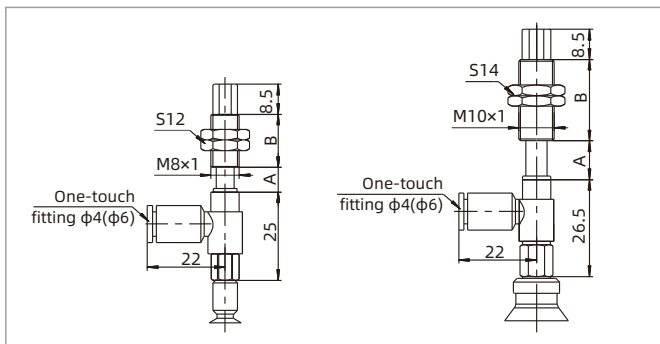

Lateral direction Suction cup diameter 2-8 Suction cup diameter 10-32

Suction cup dia./ Size	A	B	Buffer stroke	F1 (N)	F2 (N)
2-8	6	15	6	0.8	1.2
	11	43	10	0.8	1.2
	16	43	15	0.8	1.2
	26	43	25	0.8	1.2

Suction cup dia./ Size	A	B	Buffer stroke	F1 (N)	F2 (N)
10-32	11.5	23	10	1.0	3.0
	21.5	51	20	1.0	3.0
	31.5	51	30	1.0	3.0
	41.5	77	40	1.0	3.0
	51.5	77	50	1.0	3.0

◇ Note: No thread at N, non-rotating N=4, rotating N=3

Suction cup dia./ Size	A	B	Buffer stroke	F1 (N)	F2 (N)
40-50	13	44	10	2.0	5.5
	23	44	20	2.0	5.5
	33	44	30	2.0	5.5
	53	75	50	2.0	5.5

Suction cup dia./ Size	A	B	Buffer stroke	F1 (N)	F2 (N)
2-8	8	15	6	0.8	1.2
	11	43	10	0.8	1.2
	16	43	15	0.8	1.2
	26	43	25	0.8	1.2
10-32	11	23	10	1.0	3.0
	21	51	20	1.0	3.0
	31	51	30	1.0	3.0
	41	77	40	1.0	3.0
	51	77	50	1.0	3.0

◇ Note: "F1" means spring force at 0 stroke, "F2" means spring force at max. stroke

# SPH Series

## Conductive/Mark-free Suction Cup



ELECTRONICS



### Features

- ◇ Made of conductive material, with a surface resistance range of 10E6~10E9Ω.cm
- ◇ The raw material is stable, does not contain carbon powder, and will not release colored substances during use
- ◇ The installation accessories are made of stainless steel.
- ◇ The dimensions and shapes are available in various specifications.
- ◇ Various dimensions and shapes



### Applications

- ◇ It can be used in conditions requiring electrostatic protection, such as electronic products
- ◇ It can be applied in conditions requiring mark-free gripping, such as glass and panels
- ◇ It can be used in lithium battery, semiconductor and other industries
- ◇ Can meet a variety of different sizes and shapes of the workpiece

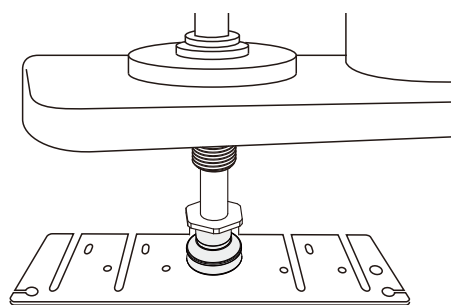

### How to order

SPH C 10 CH - M5M  
 ① ② ③ ④ ⑤

① Series	② Suction cup type	③ Diameter		④ Material & Hardness	⑤ Connection thread
SPH	U - Flat	4 - φ4mm	10 - φ10mm	CH - Conductive/ Mark-free rubber	Nil - Suction cup only M5M - M5×0.8 male thread
	C - Flat with ribs	5 - φ5mm	13 - φ13mm		
	B - 1.5 Bellows	6 - φ6mm	15 - φ15mm		
	MT - Thin lip flat suction cup	8 - φ8mm	16 - φ16mm		

◇ Note: The surface resistivity is 10E6~10E9Ω.cm

### Selection

Diameter of suction cup	Suction cup type				Connection thread M5M	MPQ pcs
	C	B	U	MT		
φ4	●	●	-	-	●	10
φ5	-	-	●	-	●	10
φ6	●	●	●	-	●	10
φ8	●	●	-	-	●	10
φ10	●	●	-	●	●	10
φ13	●	●	-	-	●	10
φ15	-	-	-	●	●	10
φ16	●	●	-	-	●	10

◇ Note: "●" default, in stock, "-" unavailable

- SZ
- SPH
- SP3
- SUF
- SAN
- SAO
- SOFA
- STP
- SFT
- SFA
- SBT
- SBL
- SBLP
- SBS
- SFP
- SBP
- SXP
- SGP
- SBOF
- STC
- SFF
- SOB
- SOF
- SOG
- SFM
- SOM
- SBF
- SDM
- SFU
- SFK
- SHT
- SDL
- SFG
- SFGT
- SFD
- SB
- SBA
- SF
- SU
- SP2F
- SPA
- SPD
- SPF
- SPC
- SPJ
- SPU
- SH
- SHB
- SBB
- SOP
- SNP

# SPH Series

## Conductive/Mark-free Suction Cup

### Dimensions(mm) - C type

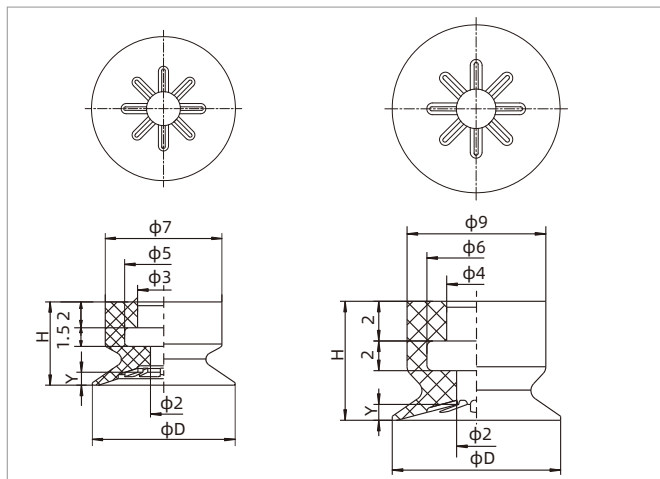

SPHC4-8

SPHC10-16

Model/Size	D	H	Y	Weight g
SPHC4	4.5	6.0	0.5	0.3
SPHC6	6.5	6.0	0.8	0.3
SPHC8	8.5	6.0	0.8	0.3
SPHC10	11.0	7.0	1.0	0.6
SPHC13	14.0	7.0	1.2	0.7
SPHC16	17.0	7.0	1.2	0.8

### Dimensions(mm) - B type

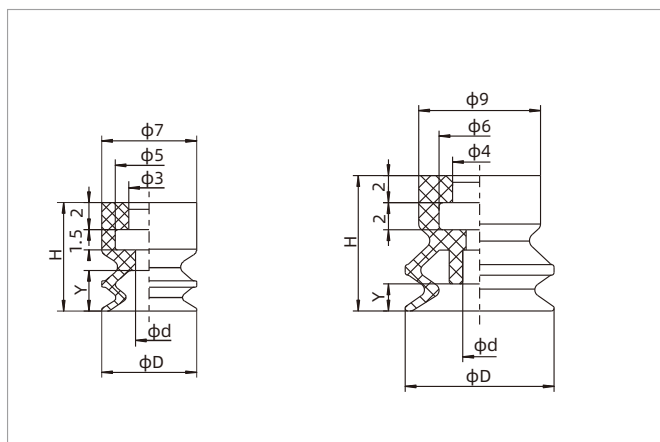

SPHB4-8

SPHB10-16

Model/Size	D	H	d	Y	Weight g
SPHB4	4.5	8.0	1.8	2.2	0.3
SPHB6	7.0	8.0	2.0	3.0	0.3
SPHB8	9.0	8.0	2.0	3.0	0.4
SPHB10	11.0	10.0	2.0	2.0	0.8
SPHB13	14.0	10.0	3.0	2.0	1.0
SPHB16	17.0	10.0	3.0	2.0	1.1

### Dimensions(mm) - U type

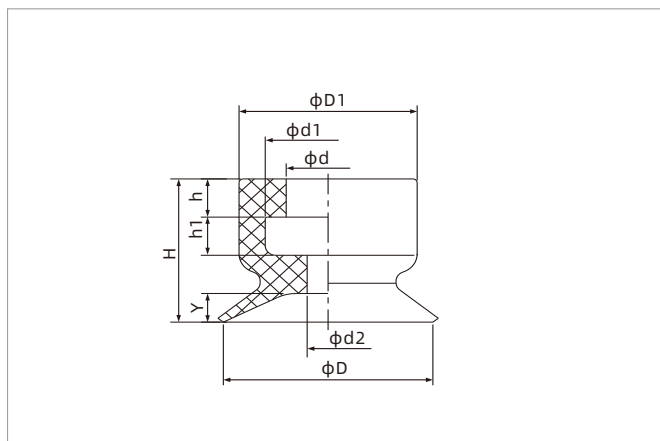

SPHU5-6

Model/Size	D	H	D1	d	h	d1	h1	d2	Y
SPHU5	5	6.5	7.5	4	2	6	2	1.4	0.8
SPHU6	6	6.5	7.5	4	2	6	2	2	0.8

# SPH Series

## Conductive/Mark-free Suction Cup



### Dimensions(mm) - MT type

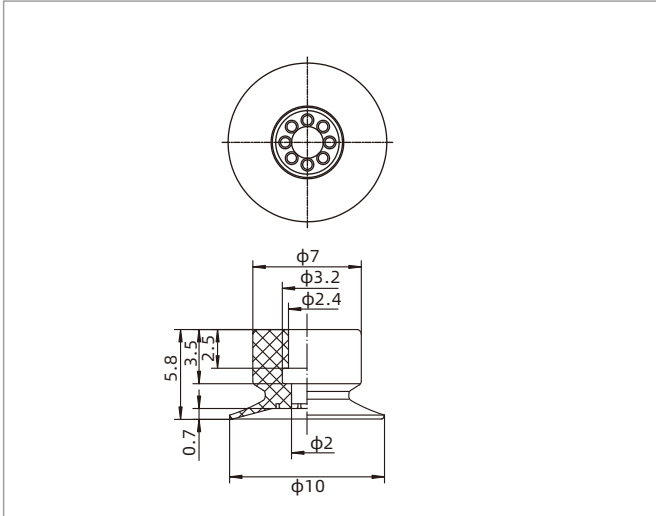

SPHMT10

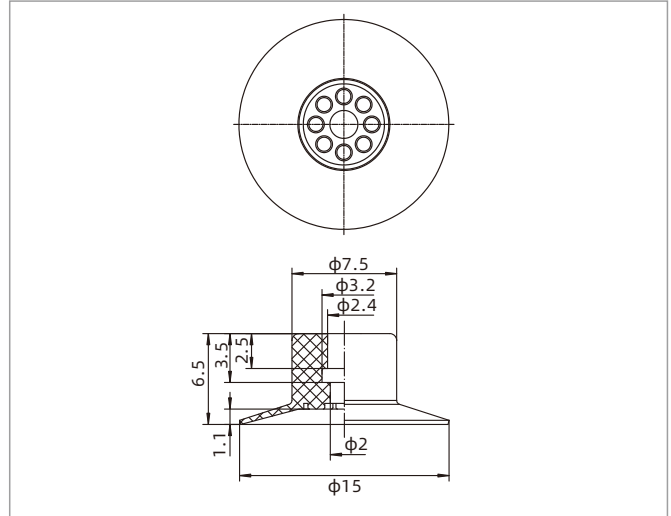

SPHMT15

### Dimensions(mm) - Suction Cup with Locking Fitting

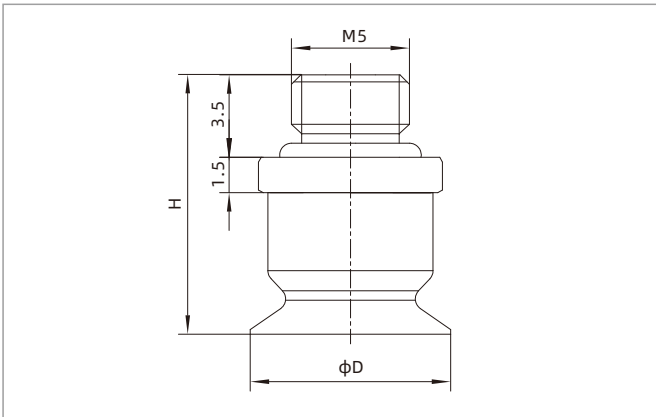

SPHC□CH-M5M

Model/Size	D	H	Weight g
SPHC4CH-M5M	4.5	11.0	1.7
SPHC6CH-M5M	6.5	11.0	1.7
SPHC8CH-M5M	8.5	11.0	1.7
SPHC10CH-M5M	11.0	12.0	3.0
SPHC13CH-M5M	14.0	12.0	3.1
SPHC16CH-M5M	17.0	12.0	3.2

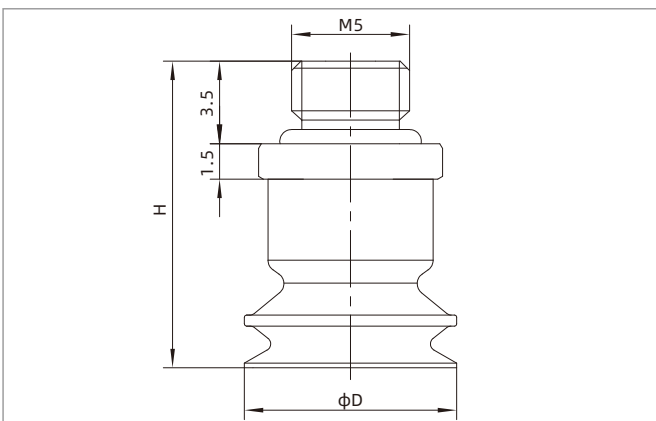

SPHB□CH-M5M

Model/Size	D	H	Weight g
SPHB4CH-M5M	4.5	13.0	0.3
SPHB6CH-M5M	7.0	13.0	0.3
SPHB8CH-M5M	9.0	13.0	0.4
SPHB10CH-M5M	11.0	15.0	0.8
SPHB13CH-M5M	14.0	15.0	1.0
SPHB16CH-M5M	17.0	15.0	1.1

- SZ
- SPH
- SP3
- SUF
- SAN
- SAO
- SOFA
- STP
- SFT
- SFA
- SBT
- SBL
- SBLP
- SBS
- SFP
- SBP
- SXP
- SGP
- SBOF
- STC
- SFF
- SOB
- SOF
- SOG
- SFM
- SOM
- SBF
- SDM
- SFU
- SFK
- SHT
- SDL
- SFG
- SFGT
- SFD
- SB
- SBA
- SF
- SU
- SP2F
- SPA
- SPD
- SPF
- SPC
- SPJ
- SPU
- SH
- SHB
- SBB
- SOP
- SNP

# SPH Series

## Conductive/Mark-free Suction Cup

### Dimensions(mm) - Suction Cup with Locking Fitting

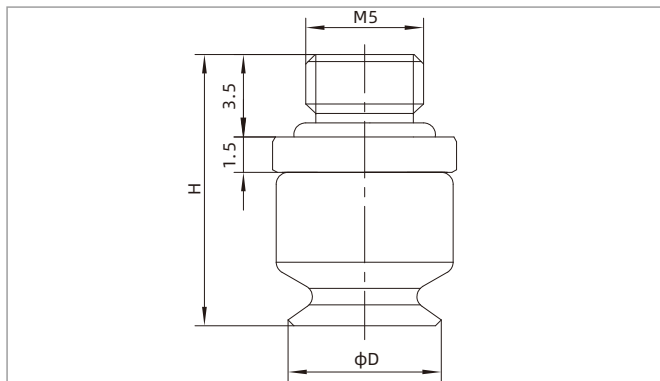

SPHU□CH-M5M

Model/Size	D	H	Weight g
SPHU5CH-M5M	5.0	11.5	0.2
SPHU6CH-M5M	6.0	11.5	0.2

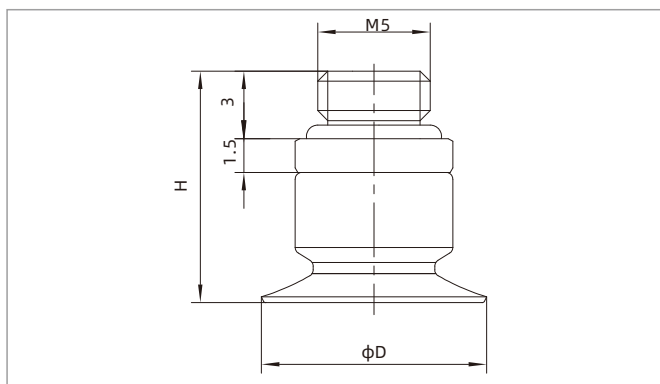

SPHMT□CH-M5M

Model/Size	D	H	Weight g
SPHMT10CH-M5M	10.0	10.3	0.2
SPHMT10CH-M5M	15.0	11.0	0.3

◇ Note: The dimensional tolerance conforms to the GB/T 3672.1-2002-1 M3 rubber product dimensional tolerance standard

### Spare Parts Selection - Fitting

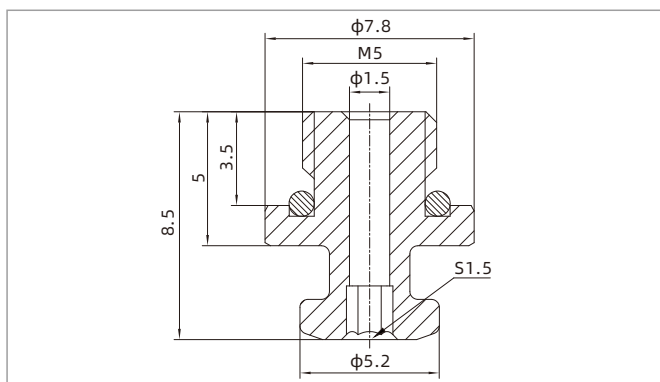

Model/Size	Applicable suction cup
PJS-M5M-ST1.5-SS	SPHB4、6、8 SPHC4、6、8

# SPH Series

## Conductive/Mark-free Suction Cup

### Spare Parts Selection - Fitting

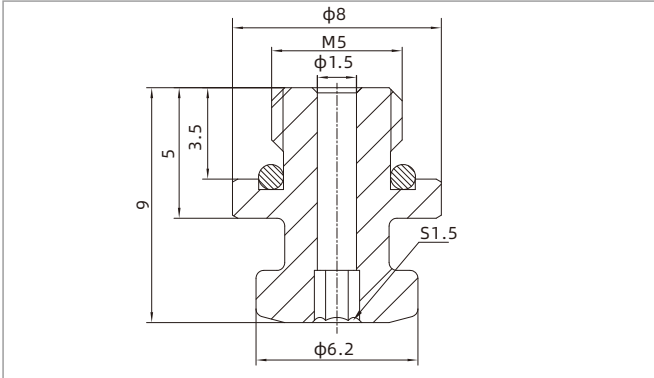

Model/Size	Applicable suction cup
PJS-M5M-ST2-SS	SPHB10、13、16
	SPHC10、13、16
	SPHU5、6

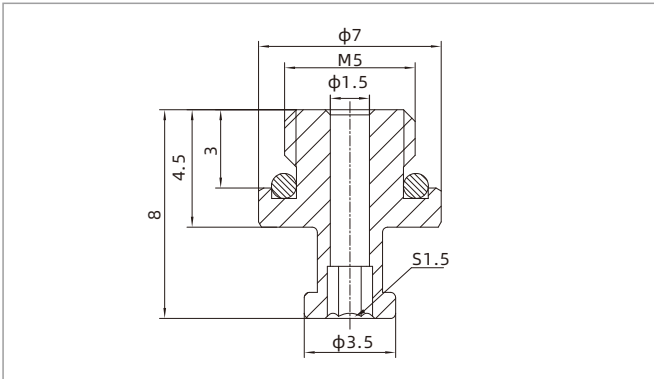

Model/Size	Applicable suction cup
PJS-M5M-SPD-SS	SPHMT10、15

### Spare Parts Selection - Spare parts selection-Level compensator

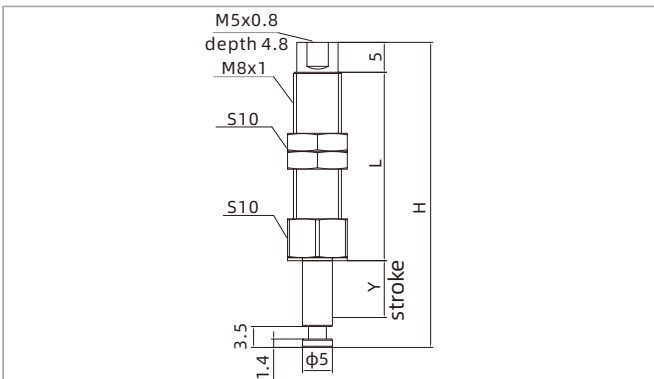

PSPS-I□D5-M8

Model/Size	H	L	Y	F1 N	F2 N
PSPS-I3D5-M8	32.5	21.5	3	0.7	0.9
PSPS-I10D5-M8	51	31.5	10	0.5	0.8

- ◇ Note: 1. "F1" means spring elastic force at 0 stroke, "F2" means spring elastic force at half stroke.
- 2. M8 nut locking torque 2.5~3.5N.m, please use in the specified torque range.

- SZ
- SPH
- SP3
- SUF
- SAN
- SAO
- SOFA
- STP
- SFT
- SFA
- SBT
- SBL
- SBLP
- SBS
- SFP
- SBP
- SPX
- SGP
- SBOF
- STC
- SFF
- SOB
- SOF
- SOG
- SFM
- SOM
- SBF
- SDM
- SFU
- SKF
- SHT
- SDL
- SFG
- SFGT
- SFD
- SB
- SBA
- SF
- SU
- SP2F
- SPA
- SPD
- SPF
- SPC
- SPJ
- SPU
- SH
- SHB
- SBB
- SOP
- SNP

# SPH Series

## Conductive/Mark-free Suction Cup

### Spare Parts Selection - Spare parts selection-Level compensator

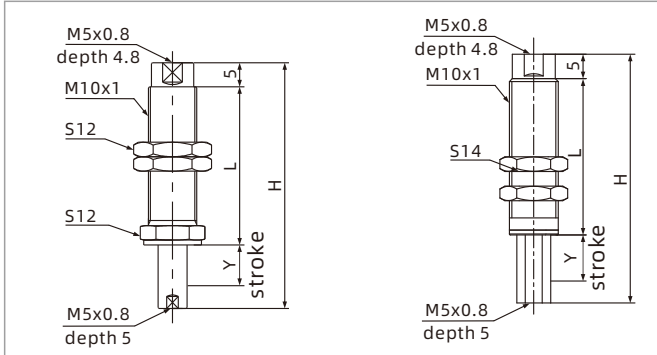

PPSP-□M5F-M10

PPSP-□RM5F-M10

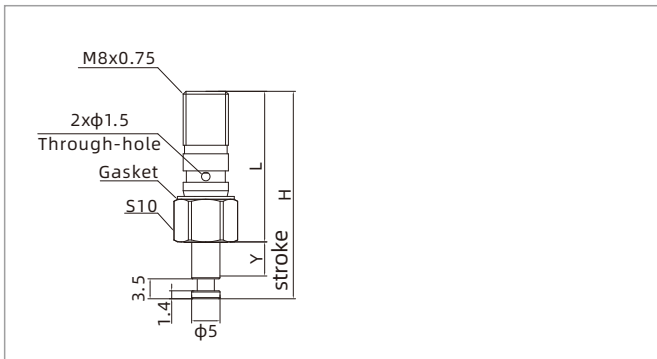

PPSP-I6D5-I8

Model/Size	H	L	Y	F1 N	F2 N
PPSP-I10M5F-M10	51	31.8	10	1.0	1.4
PPSP-I15M5F-M10	61	36.8	15	1.0	1.4
PPSP-I20M5F-M10	71	41.8	20	1.0	1.4
PPSP-I6RM5F-M10	43	28	6	0.9	1.2
PPSP-I10RM5F-M10	51	32	10	0.9	1.2

- ◇ Note: 1. "F1" means spring elastic force at 0 stroke, "F2" means spring elastic force at half stroke.
- 2. M10 nut locking torque 2.5~3.5N.m, please use in the specified torque range.

Model/Size	H	L	Y	F1 N	F2 N
PPSP-I6D5-I8	36.5	26.5	6	0.7	0.9

- ◇ Note: 1. "F1" means spring elastic force at 0 stroke, "F2" means spring elastic force at half stroke.
- 2. The inserted level compensator may cause 0~1kPa press drop due to different operating conditions and use environment.
- 3. Do not plug the hole at the top of the nut cover when using the inserted level compensator.

Level compensator model	Buffer type	Buffer stroke	Applicable suction cup
PPSP-I3D5-M8	Vertical rotating	3	SPHB4
PPSP-I10D5-M8	Vertical rotating	10	SPHB6
PPSP-I6D5-I8	Vertical rotating	6	SPHB8
PPSP-I10M5F-M10	Vertical rotating	10	SPHC4-M5M、SPHC6-M5M、SPHC8-M5M、SPHC10-M5M、
PPSP-I15M5F-M10	Vertical rotating	15	SPHC13-M5M、SPHC16-M5M、SPHB4-M5M、SPHB6-M5M、
PPSP-I20M5F-M10	Vertical rotating	20	SPHB8-M5M、SPHB10-M5M、SPHB13-M5M、SPHB16-M5M、
PPSP-I6RM5F-M10	Vertical non-rotating	6	SPHU5-M5M、SPHU6-M5MSPHMT10-M5M、SPHMT15-M5M
PPSP-I10RM5F-M10	Vertical non-rotating	10	

# SP3 Series

## Suction Cup



### Features

- ◇ Suction cups of same diameter among U/C/B types use same fitting
- ◇ Small size, short height
- ◇ Available in conductive material

### Advantages

- ◇ Used in various occasions, suction cups are interchangeable
- ◇ Suitable for occasions with limited space
- ◇ Discharge static electricity gently to protect workpieces from damage



U-Flat



C-Flat with ribs



B-1.5 bellows

### Applications

- ◇ U type suitable for workpieces with even surface and without deformation
- ◇ C type suitable for easily deformed workpieces
- ◇ B type suitable for workpieces with inclined surface
- ◇ Suitable for handling of workpieces with small size and light weight
- ◇ Conductive material suitable for 3C industry

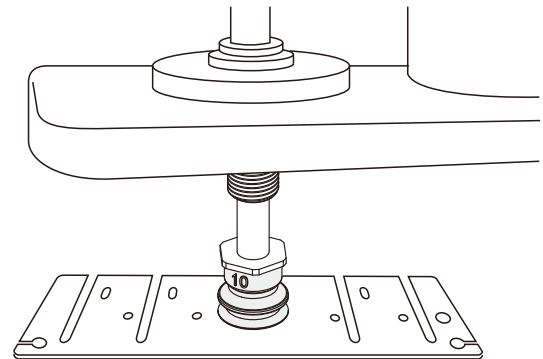

### Structure

- ◇ Split structure for easy replacement of wearing parts

In the same series, replacement suction cup and locking fitting can be combined as required

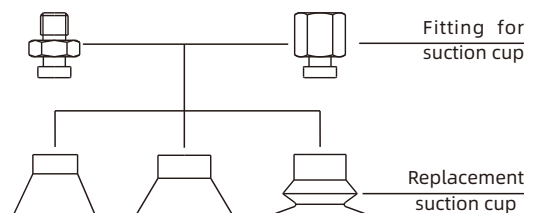

- SZ
- SPH
- SP3**
- SUF
- SAN
- SAO
- SOFA
- STP
- SFT
- SFA
- SBT
- SBL
- SBLP
- SBS
- SFP
- SBP
- SXP
- SGP
- SBOF
- STC
- SFF
- SOB
- SOF
- SOG
- SFM
- SOM
- SBF
- SDM
- SFU
- SFK
- SHT
- SDL
- SFG
- SFGT
- SFD
- SB
- SBA
- SF
- SU
- SP2F
- SPA
- SPD
- SPF
- SPC
- SPJ
- SPU
- SH
- SHB
- SBB
- SOP
- SNP

# SP3 Series

## Suction Cup

### How to order

SP3 B 10 N - M5M  
 ① ② ③ ④ ⑤

① Series	② Suction cup type	③ Diameter	④ Material & Hardness	⑤ Connection thread
SP3	U - Flat	1.5 - $\phi$ 1.5mm 2 - $\phi$ 2mm	N - NBR <span style="background-color: black; color: white; padding: 2px;">55</span>	Nil - Suction cup only
	C - Flat with ribs	3.5 - $\phi$ 3.5mm 4 - $\phi$ 4mm	WS - White silicone <span style="border: 1px solid black; padding: 2px;">50</span>	M3F - M3×0.5 female thread
	B - 1.5 Bellows	10 - $\phi$ 10mm 6 - $\phi$ 6mm	CN - Conductive NBR <span style="background-color: black; color: white; padding: 2px;">55</span>	M5F - M5×0.8 female thread
		13 - $\phi$ 13mm 8 - $\phi$ 8mm	CS - Conductive silicone <span style="background-color: black; color: white; padding: 2px;">55</span>	M3M - M3×0.5 male thread
		16 - $\phi$ 16mm	HP - Mark free rubber <span style="background-color: black; color: white; padding: 2px;">55</span>	M5M - M5×0.8 male thread

◇ Note: HP material is not for all sizes. Please contact AIRBEST if need

### Selection

Diameter of suction cup	Suction cup type			Connection thread				MPQ pcs
	U	C	B	M3F	M3M	M5F	M5M	
$\phi$ 1.5	●	-	-	●	●	-	-	10
$\phi$ 2	●	-	-	●	●	-	-	10
$\phi$ 3.5	●	-	-	●	●	-	-	10
$\phi$ 4	-	●	●	-	-	●	●	10
$\phi$ 6	-	●	●	-	-	●	●	10
$\phi$ 8	-	●	●	-	-	●	●	10
$\phi$ 10	-	●	●	-	-	●	●	10
$\phi$ 13	-	●	●	-	-	●	●	10
$\phi$ 16	-	●	●	-	-	●	●	10

◇ Note: "●" default, in stock, "-" unavailable

# SP3 Series

## Suction Cup

### Dimensions(mm) - U type

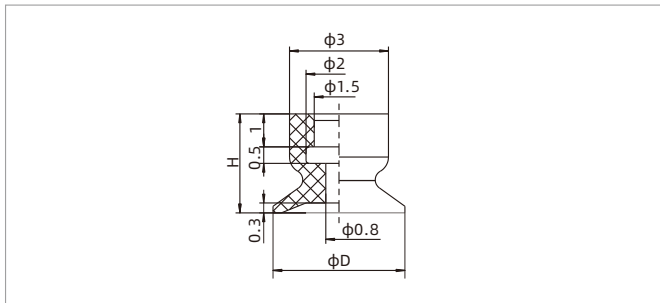

SP3U1.5-3.5

Model/Size	D	H	Weight g
SP3U1.5□	2.0	3.0	0.1
SP3U2□	2.5	3.0	0.1
SP3U3.5□	4.0	3.0	0.1

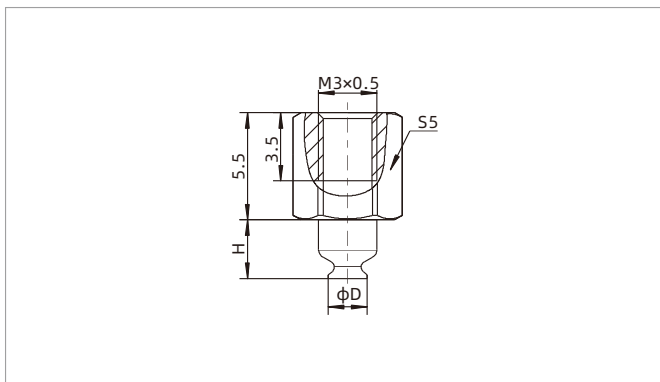

SP3U1.5-3.5 F - Female thread connection

Model/Size	D	H	Weight g
SP3U1.5□-M3F	2.0	3.0	0.9
SP3U2□-M3F	2.5	3.0	0.9
SP3U3.5□-M3F	4.0	3.0	0.9

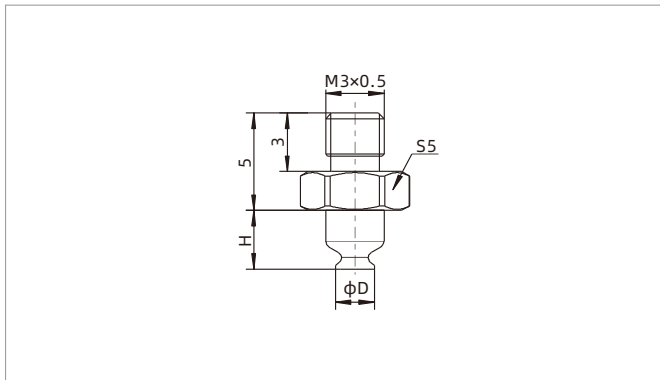

SP3U1.5-3.5 M - Male thread connection

Model/Size	D	H	Weight g
SP3U1.5□-M3M	2.0	3.0	0.6
SP3U2□-M3M	2.5	3.0	0.6
SP3U3.5□-M3M	4.0	3.0	0.6

- SZ
- SPH
- SP3**
- SUF
- SAN
- SAO
- SOFA
- STP
- SFT
- SFA
- SBT
- SBL
- SBLP
- SBS
- SFP
- SBP
- SXP
- SGP
- SBOF
- STC
- SFF
- SOB
- SOF
- SOG
- SFM
- SOM
- SBF
- SDM
- SFU
- SFK
- SHT
- SDL
- SFG
- SFGT
- SFD
- SB
- SBA
- SF
- SU
- SP2F
- SPA
- SPD
- SPF
- SPC
- SPJ
- SPU
- SH
- SHB
- SBB
- SOP
- SNP

# SP3 Series

## Suction Cup

### Dimensions(mm) - C type

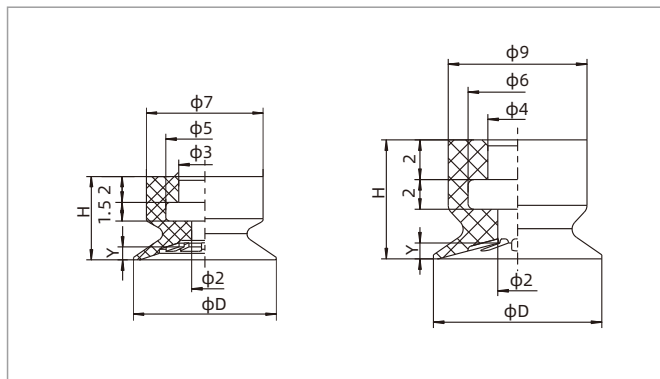

SP3C4-8

SP3C10-16

Model/Size	D	H	Y	Weight g
SP3C4□	4.5	6.0	0.5	0.3
SP3C6□	6.5	6.0	0.8	0.3
SP3C8□	8.5	6.0	0.8	0.3
SP3C10□	11.0	7.0	1.0	0.6
SP3C13□	14.0	7.0	1.2	0.7
SP3C16□	17.0	7.0	1.2	0.8

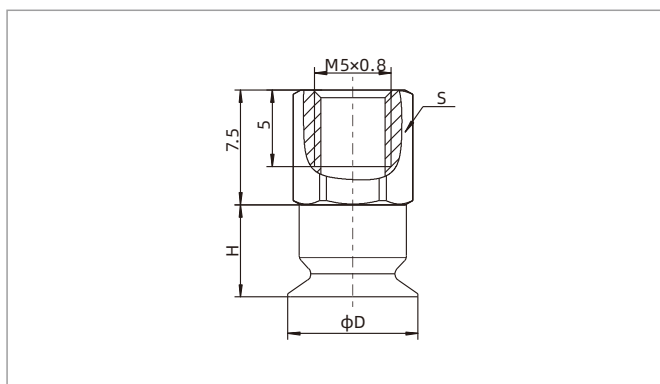

SP3C4-16 F - Female thread connection

Model/Size	D	H	S	Weight g
SP3C4□-M5F	4.5	6.0	7.0	2.3
SP3C6□-M5F	6.5	6.0	7.0	2.3
SP3C8□-M5F	8.5	6.0	7.0	2.3
SP3C10□-M5F	11.0	7.0	10.0	5.7
SP3C13□-M5F	14.0	7.0	10.0	5.8
SP3C16□-M5F	17.0	7.0	10.0	5.9

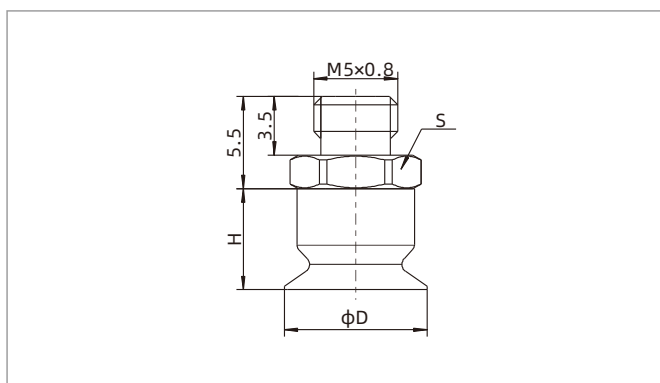

SP3C4-16 M - Male thread connection

Model/Size	D	H	S	Weight g
SP3C4□-M5M	4.5	6.0	7.0	1.7
SP3C6□-M5M	6.5	6.0	7.0	1.7
SP3C8□-M5M	8.5	6.0	7.0	1.7
SP3C10□-M5M	11.0	7.0	10.0	3.0
SP3C13□-M5M	14.0	7.0	10.0	3.1
SP3C16□-M5M	17.0	7.0	10.0	3.2

# SP3 Series

## Suction Cup

### Dimensions(mm) - B type

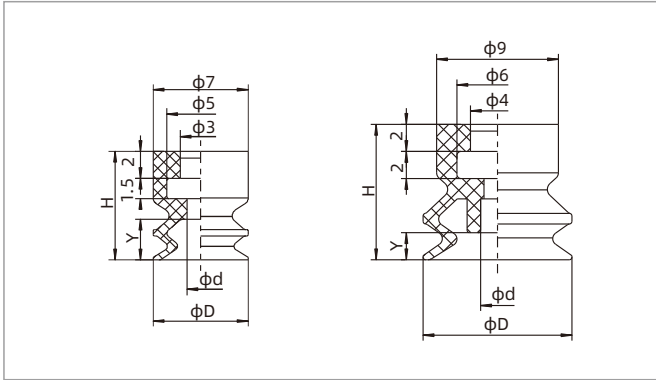

SP3B4-8

SP3B10-16

Model/Size	D	H	d	Y	Weight g
SP3B4□	4.5	8.0	1.8	2.2	0.3
SP3B6□	7.0	8.0	2.0	3.0	0.3
SP3B8□	9.0	8.0	2.0	3.0	0.4
SP3B10□	11.0	10.0	2.0	2.0	0.8
SP3B13□	14.0	10.0	3.0	2.0	1.0
SP3B16□	17.0	10.0	3.0	2.0	1.1

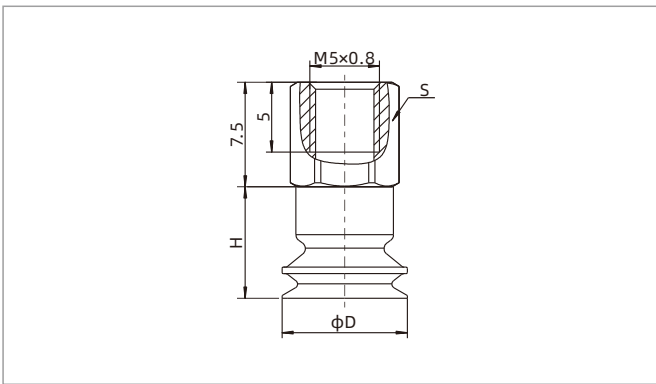

SP3B4-16 F - Female thread connection

Model/Size	D	H	S	Weight g
SP3B4□-M5F	4.5	8.0	7.0	2.3
SP3B6□-M5F	7.0	8.0	7.0	2.3
SP3B8□-M5F	9.0	8.0	7.0	2.4
SP3B10□-M5F	11.0	10.0	10.0	5.9
SP3B13□-M5F	14.0	10.0	10.0	6.1
SP3B16□-M5F	17.0	10.0	10.0	6.2

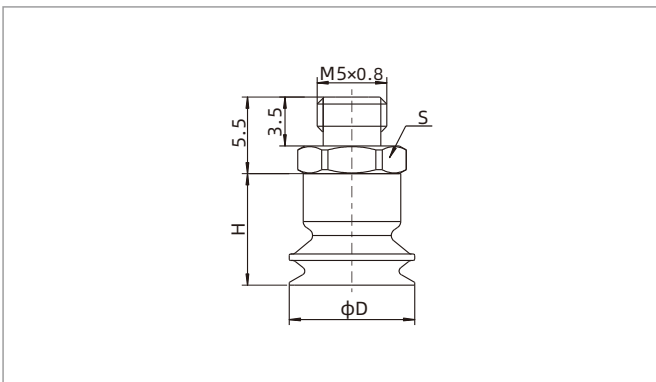

SP3B4-16 M - Male thread connection

◇ Note: The dimensional tolerance conforms to the GB/T 3672.1-2002-1 M3 rubber product dimensional tolerance standard

Model/Size	D	H	S	Weight g
SP3B4□-M5M	4.5	8.0	7.0	1.7
SP3B6□-M5M	7.0	8.0	7.0	1.7
SP3B8□-M5M	9.0	8.0	7.0	1.8
SP3B10□-M5M	11.0	10.0	10.0	3.2
SP3B13□-M5M	14.0	10.0	10.0	3.4
SP3B16□-M5M	17.0	10.0	10.0	3.5

### Mounting parts

Item	Model		Applicable suction cup
	Female thread	Male thread	
Fitting for suction cup	PJS-M3F-ST0.5	PJS-M3M-ST0.5	SP3U1.5, 2, 3.5
	PJS-M5F-ST1.5	PJS-M5M-ST1.5	SP3C4, 6, 8; SP3B4, 6, 8
	PJS-M5F-ST2	PJS-M5M-ST2-A	SP3C10, 13, 16; SP3B10, 13, 16

- SZ
- SPH
- SP3
- SUF
- SAN
- SAO
- SOFA
- STP
- SFT
- SFA
- SBT
- SBL
- SBLP
- SBS
- SFP
- SBP
- SXP
- SGP
- SBOF
- STC
- SFF
- SOB
- SOF
- SOG
- SFM
- SOM
- SBF
- SDM
- SFU
- SFK
- SHT
- SDL
- SFG
- SFGT
- SFD
- SB
- SBA
- SF
- SU
- SP2F
- SPA
- SPD
- SPF
- SPC
- SPJ
- SPU
- SH
- SHB
- SBB
- SOP
- SNP

# SP3 Series

## Suction Cup with Locking Fitting

### Structure

- ◇ Consisting of replacement suction cup(3) and locking fitting(1 or 2)
- ◇ Plug-in fitting for suction cup
- ◇ Vertical vacuum port(1), male thread for mounting
- ◇ Lateral vacuum port(2), female thread for mounting

In the same series, replacement suction cup and locking fitting can be combined as required

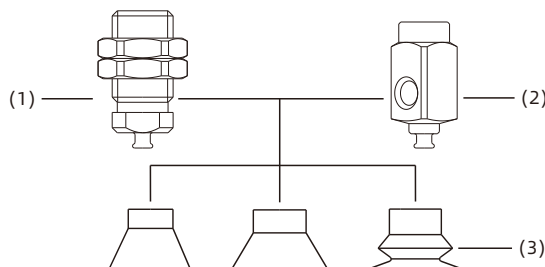

### How to order

**SP3B10N - L M5F - M5F**  
 ①                      ②      ③                      ④

① Model	② Vacuum port direction	③ Vacuum port connection	④ Mounting thread
SP3B10N	Nil - Vertical	M3F - M3×0.5 female thread	M3F - M3×0.5 female thread
	L - Lateral	M5F - M5×0.8 female thread	M5F - M5×0.8 female thread
			M6M - M6×0.75 male thread
			M10M - M10×1 male thread
			M12M - M12×1 male thread

◇ Please refer to page 170 for suction cup selection

### Selection

Model	Nil-Vertical Vacuum port connection	Mounting thread	L- Lateral Vacuum port connection	Mounting thread
SP3U1.5-3.5	M3F	M6M	M3F	M3F
SP3C4-8	M5F	M10M	M5F	M5F
SP3C10-16	M5F	M12M	M5F	M5F
SP3B4-8	M5F	M10M	M5F	M5F
SP3B10-16	M5F	M12M	M5F	M5F



# SP3 Series

## Suction Cup with Locking Fitting

### Dimensions(mm) - C type

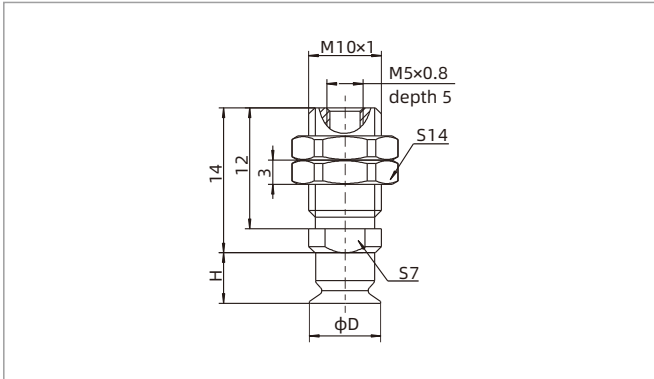

SP3C4-8 Vertical-Male thread connection

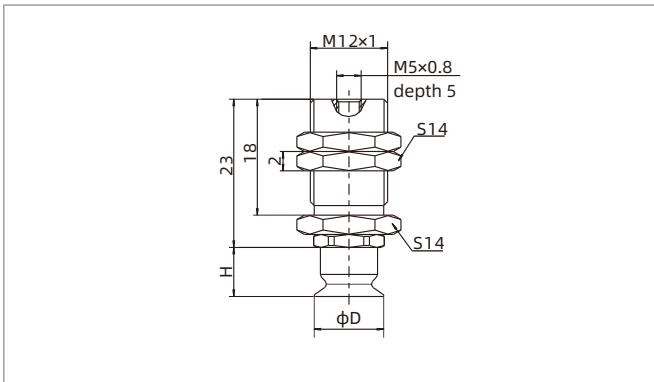

SP3C10-16 Vertical-Male thread connection

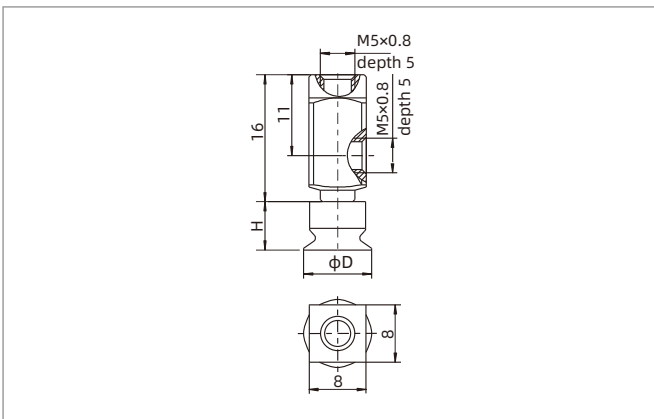

SP3C4-16 Lateral-Female thread connection

Model/Size	D	H	Weight g
SP3C4□-M5F-M10M	4.5	6.0	11.0
SP3C6□-M5F-M10M	6.5	6.0	11.0
SP3C8□-M5F-M10M	8.5	6.0	11.0

Model/Size	D	H	Weight g
SP3C10□-M5F-M12M	11.0	7.0	18.8
SP3C13□-M5F-M12M	14.0	7.0	18.9
SP3C16□-M5F-M12M	17.0	7.0	19.0

Model/Size	D	H	Weight g
SP3C4□-LM5F-M5F	4.5	6.0	7.0
SP3C6□-LM5F-M5F	6.5	6.0	7.0
SP3C8□-LM5F-M5F	8.5	6.0	7.0
SP3C10□-LM5F-M5F	11.0	7.0	7.7
SP3C13□-LM5F-M5F	14.0	7.0	7.8
SP3C16□-LM5F-M5F	17.0	7.0	7.9

# SP3 Series

## Suction Cup with Locking Fitting

### Dimensions(mm) -B type

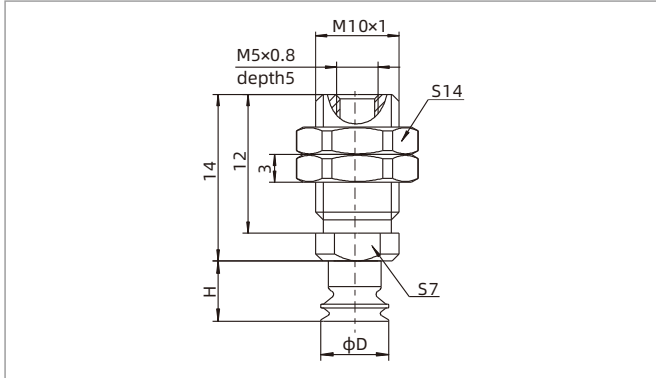

SP3B□□-M5F-M10M

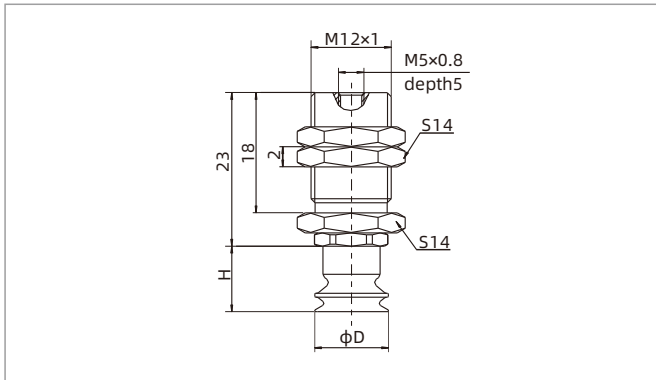

SP3B□□-M5F-M12M

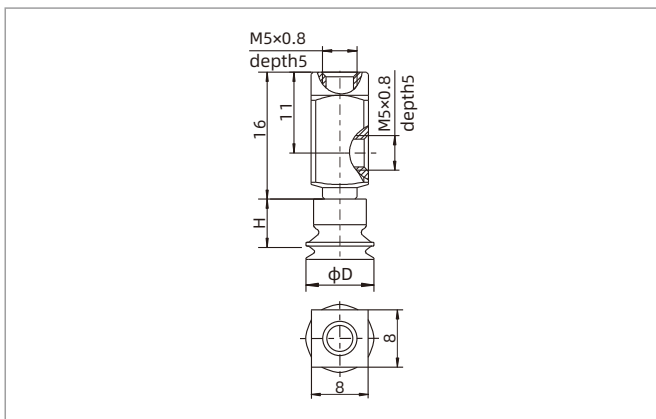

SP3B□□-LM5F-M5F

Model/Size	D	H	Weight g
SP3B4□-M5F-M10M	4.5	8.0	11.0
SP3B6□-M5F-M10M	7.0	8.0	11.0
SP3B8□-M5F-M10M	9.0	8.0	11.1

Model/Size	D	H	Weight g
SP3B10□-M5F-M12M	11.0	10.0	19.0
SP3B13□-M5F-M12M	14.0	10.0	19.2
SP3B16□-M5F-M12M	17.0	10.0	19.3

Model/Size	D	H	Weight g
SP3B4□-LM5F-M5F	4.5	8.0	7.0
SP3B6□-LM5F-M5F	7.0	8.0	7.0
SP3B8□-LM5F-M5F	9.0	8.0	7.1
SP3B10□-LM5F-M5F	11.0	10.0	7.9
SP3B13□-LM5F-M5F	14.0	10.0	8.1
SP3B16□-LM5F-M5F	17.0	10.0	8.2

- SZ
- SPH
- SP3
- SUF
- SAN
- SAO
- SOFA
- STP
- SFT
- SFA
- SBT
- SBL
- SBLP
- SBS
- SFP
- SBP
- SXP
- SGP
- SBOF
- STC
- SFF
- SOB
- SOF
- SOG
- SFM
- SOM
- SBF
- SDM
- SFU
- SFK
- SHT
- SDL
- SFG
- SFGT
- SFD
- SB
- SBA
- SF
- SU
- SP2F
- SPA
- SPD
- SPF
- SPC
- SPJ
- SPU
- SH
- SHB
- SBB
- SOP
- SNP

### Mounting parts

Item	Model		Applicable suction cup
	Vertical direction	Lateral direction	
Locking fitting	PJF-M3F-M6M-ST0.5	PJF-LM3F-M3F-ST0.5	SP3U1.5, 2, 3.5
	PJF-M5F-M10M-ST1.5	PJF-LM5F-M5F-ST1.5	SP3C4, 6, 8; SP3B4, 6, 8
	PJF-M5F-M12M-ST2	PJF-LM5F-M5F-ST2	SP3C10, 13, 16; SP3B10, 13, 16

# SP3 Series

## Suction Cup with Level Compensator

### Structure

- ◇ Consisting of replacement suction cup(3) and level compensator(1 or 2)
- ◇ Plug-in fitting for suction cup
- ◇ Vertical vacuum port(1), male thread for mounting
- ◇ Lateral vacuum port(2), male thread for mounting

In the same series, replacement suction cup and level compensator can be combined as required

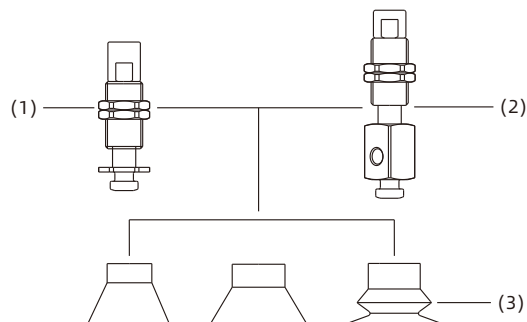

### How to order

SP3B10N - I 10 R - M8  
 ①                      ②   ③   ④                      ⑤

① Model	② Vacuum port direction	③ Buffer stroke		④ Rotary type	⑤ Mounting thread
SP3B10N	I - Vertical	3	15	Nil - Rotating	M6 - M6×0.75
	L - Lateral	6	20	R - Non-rotating	M8 - M8×0.75
		10			

◇ Please refer to page 170 for suction cup selection

### Selection

Model	Vacuum port direction		Rotary type		Buffer stroke	Mounting thread
	I-Vertical	L-Lateral	Nil-Rotating	R-Non-rotating		
SP3U1.5-3.5	●	●	●	-	3 6	M6
SP3U1.5-3.5	●	●	-	●	3 6	M8
SP3C4-16	●	●	●	●	3 6 10 15 20	M8
SP3B4-16	●	●	●	●	3 6 10 15 20	M8

◇ Note: "●" default, in stock, "-" unavailable

# SP3 Series

## Suction Cup with Level Compensator

### Dimensions(mm) -U type

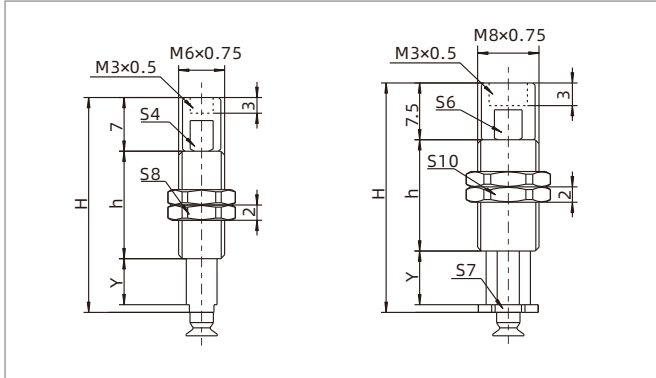

SP3U1.5-3.5 Vertical rotating

SP3U1.5-3.5 Vertical non-rotating

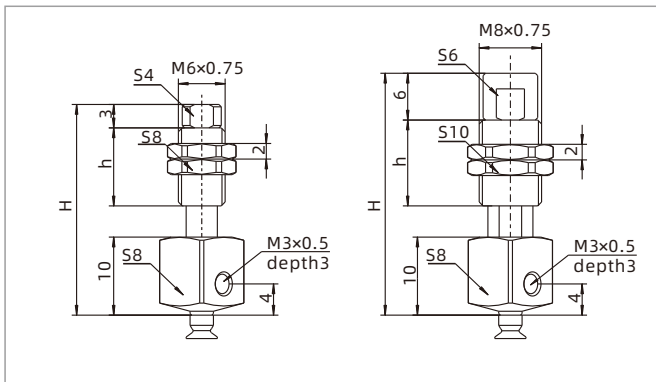

SP3U1.5-3.5 Lateral rotating

SP3U1.5-3.5 Lateral non-rotating

Model/Size	H	h	Y	Buffer stroke	F1 N	F2 N	F3 N	Weight g
SP3U□-I3-M6	21.0	10.0	3.0	3	0.7	1.0	1.2	3.4
SP3U□-I3R-M8	23.5	11.0	3.0	6	0.8	1.0	1.2	6.8
SP3U□-I6-M6	28.0	14.0	6.0	3	0.8	1.0	1.2	4.4
SP3U□-I6R-M8	30.0	14.5	6.0	6	0.7	1.0	1.2	8.2

Model/Size	H	h	Buffer stroke	F1 N	F2 N	F3 N	Weight g
SP3U□-L3-M6	27.0	10.0	3	0.7	1.0	1.2	7.7
SP3U□-L3R-M8	31.0	11.0	6	0.8	1.0	1.2	11.0
SP3U□-L6-M6	34.0	14.0	3	0.8	1.0	1.2	8.6
SP3U□-L6R-M8	37.5	14.5	6	0.7	1.0	1.2	12.2

### Dimensions(mm) -C type

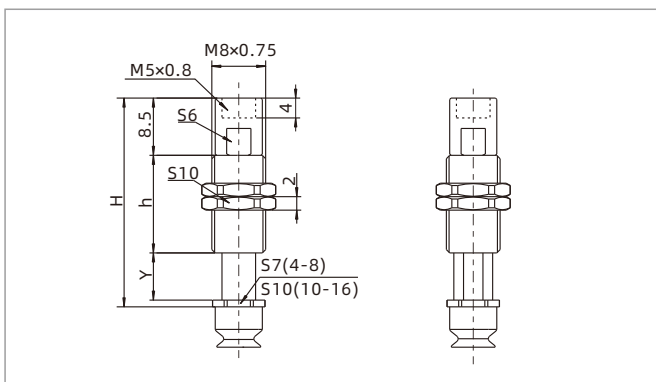

SP3C4-16 Vertical rotating

SP3C4-16 Vertical non-rotating

Model/Size	H	h	Y	Buffer stroke	F1 N	F2 N	F3 N	Weight g
SP3C□-I3-M8	24.5	11.0	4.0	3	0.8	1.0	1.2	7.4
SP3C□-I3R-M8	24.5	11.0	4.0	3	0.8	1.0	1.2	7.3
SP3C□-I6-M8	31.0	14.5	7.0	6	0.7	1.0	1.2	8.6
SP3C□-I6R-M8	31.0	14.5	7.0	6	0.7	1.0	1.2	8.6
SP3C□-I10-M8	41.0	20.5	11.0	10	0.6	1.2	1.9	10.5
SP3C□-I10R-M8	41.0	20.5	11.0	10	0.6	1.2	1.9	10.5

◇ Note: 1. Please refer to page 170 for suction cup selection  
 2. F1, F2, and F3 represent the elastic force of the buffer support rod at 0 stroke, 50% stroke, and 100% stroke

SZ  
 SPH  
 SP3  
 SUF  
 SAN  
 SAO  
 SOFA  
 STP  
 SFT  
 SFA  
 SBT  
 SBL  
 SBLP  
 SBS  
 SFP  
 SBP  
 SXP  
 SGP  
 SBFOF  
 STC  
 SFF  
 SOB  
 SOF  
 SOG  
 SFM  
 SOM  
 SBF  
 SDM  
 SFU  
 SFK  
 SHT  
 SDL  
 SFG  
 SFGT  
 SFD  
 SB  
 SBA  
 SF  
 SU  
 SP2F  
 SPA  
 SPD  
 SPF  
 SPC  
 SPJ  
 SPU  
 SH  
 SHB  
 SBB  
 SOP  
 SNP

# SP3 Series

## Suction Cup with Level Compensator

### Dimensions(mm) -C type

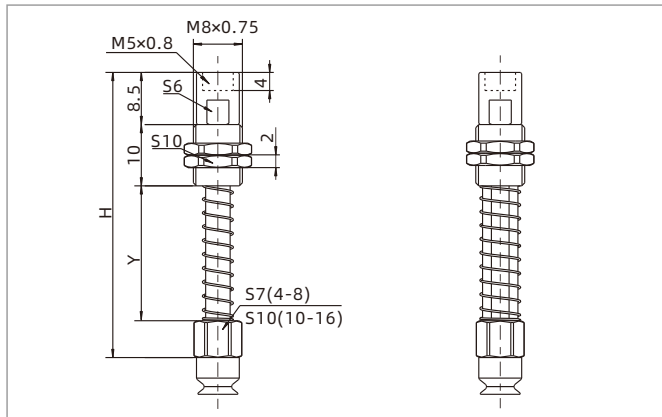

SP3C4-16 Vertical rotating

SP3C4-16 Vertical non-rotating

Model/Size	H	Y	Buffer stroke	F1 N	F2 N	F3 N	Weight g
SP3C□-I15-M8	49.0	24.5	15	0.6	1.3	1.9	10.3
SP3C□-I15R-M8	49.0	24.5	15	0.6	1.3	1.8	12.3
SP3C□-I20-M8	56.5	32.0	20	0.7	1.2	1.8	10.9
SP3C□-I20R-M8	56.5	32.0	20	0.8	1.3	1.8	13.4

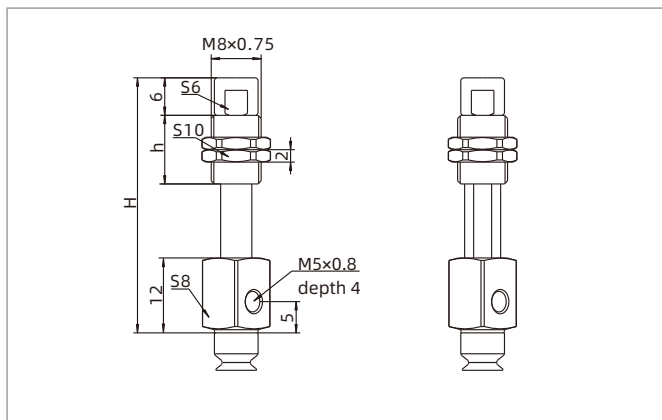

SP3C4-16 Lateral rotating

SP3C4-16 Lateral non-rotating

Model/Size	H	h	Buffer stroke	F1 N	F2 N	F3 N	Weight g
SP3C□-L3-M8	33.0	11.0	3	0.8	1.0	1.2	12.8
SP3C□-L3R-M8	33.0	11.0	3	0.8	1.0	1.2	12.2
SP3C□-L6-M8	39.5	14.5	6	0.7	1.0	1.2	14.2
SP3C□-L6R-M8	39.5	14.5	6	0.7	1.0	1.2	13.4
SP3C□-L10-M8	49.5	20.5	10	0.6	1.2	1.9	16.6
SP3C□-L10R-M8	49.5	20.5	10	0.6	1.2	1.9	15.4

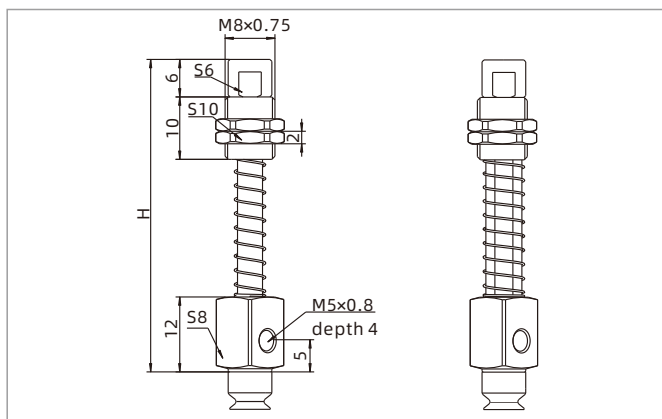

SP3C4-16 Lateral rotating

SP3C4-16 Lateral non-rotating

Model/Size	H	Buffer stroke	F1 N	F2 N	F3 N	Weight g
SP3C□-L15-M8	52.5	15	0.6	1.3	1.9	16.3
SP3C□-L15R-M8	52.5	15	0.6	1.3	1.8	15.5
SP3C□-L20-M8	60.0	20	0.7	1.2	1.8	15.1
SP3C□-L20R-M8	60.0	20	0.8	1.3	1.8	16.6

◇ Note: 1. Please refer to page 170 for suction cup selection  
 2. F1, F2, and F3 represent the elastic force of the buffer support rod at 0 stroke, 50% stroke, and 100% stroke

# SP3 Series

## Suction Cup with Level Compensator

### Dimensions(mm) -B type

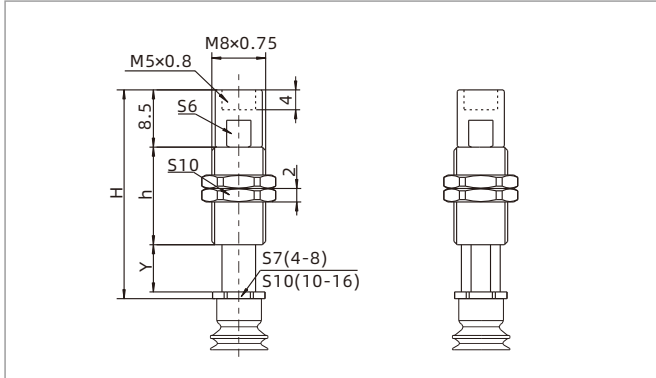

SP3B4-16 Vertical rotating

SP3B4-16 Vertical non-rotating

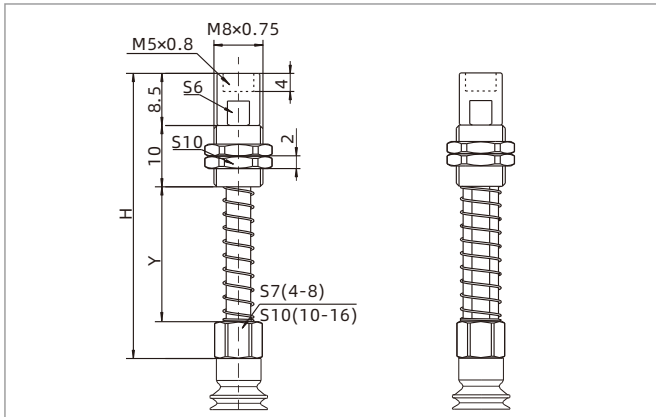

SP3B4-16 Vertical rotating

SP3B4-16 Vertical non-rotating

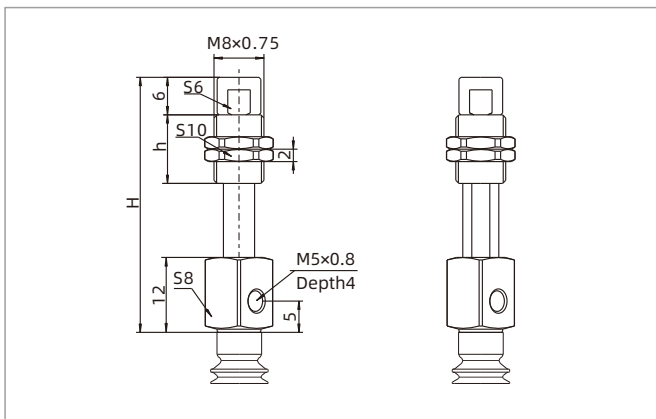

SP3B4-16 Lateral rotating

SP3B4-16 Lateral non-rotating

Model/Size	H	h	Y	Buffer stroke	F1 N	F2 N	F3 N	Weight g
SP3B□-I3-M8	24.5	11.0	4	3	0.8	1.0	1.2	7.4
SP3B□-I3R-M8	24.5	11.0	4	3	0.8	1.0	1.2	7.3
SP3B□-I6-M8	31.0	14.5	7	6	0.7	1.0	1.2	8.6
SP3B□-I6R-M8	31.0	14.5	7	6	0.7	1.0	1.2	8.6
SP3B□-I10-M8	41.0	20.5	11	10	0.6	1.2	1.9	10.5
SP3B□-I10R-M8	41.0	20.5	11	10	0.6	1.2	1.9	10.5

Model/Size	H	Y	Buffer stroke	F1 N	F2 N	F3 N	Weight g
SP3B□-I15-M8	49.0	24.5	15	0.6	1.3	1.9	10.3
SP3B□-I15R-M8	49.0	24.5	15	0.6	1.3	1.8	12.3
SP3B□-I20-M8	56.5	32.0	20	0.7	1.2	1.8	10.9
SP3B□-I20R-M8	56.5	32.0	20	0.8	1.3	1.8	13.4

Model/Size	H	h	Buffer stroke	F1 N	F2 N	F3 N	Weight g
SP3B□-L3-M8	33.0	11.0	3	0.8	1.0	1.2	12.8
SP3B□-L3R-M8	33.0	11.0	3	0.8	1.0	1.2	12.2
SP3B□-L6-M8	39.5	14.5	6	0.7	1.0	1.2	14.2
SP3B□-L6R-M8	39.5	14.5	6	0.7	1.0	1.2	13.4
SP3B□-L10-M8	49.5	20.5	10	0.6	1.2	1.9	16.6
SP3B□-L10R-M8	49.5	20.5	10	0.6	1.2	1.9	15.4

◇ Note: 1. Please refer to page 170 for suction cup selection  
 2. F1, F2, and F3 represent the elastic force of the buffer support rod at 0 stroke, 50% stroke, and 100% stroke

- SZ
- SPH
- SP3
- SUF
- SAN
- SAO
- SOFA
- STP
- SFT
- SFA
- SBT
- SBL
- SBLP
- SBS
- SFP
- SBP
- SXP
- SGP
- SBOF
- STC
- SFF
- SOB
- SOF
- SOG
- SFM
- SOM
- SBF
- SDM
- SFU
- SFK
- SHT
- SDL
- SFG
- SFGT
- SFD
- SB
- SBA
- SF
- SU
- SP2F
- SPA
- SPD
- SPF
- SPC
- SPJ
- SPU
- SH
- SHB
- SBB
- SOP
- SNP

# SP3 Series

## Suction Cup with Level Compensator

### Dimensions(mm) -B type

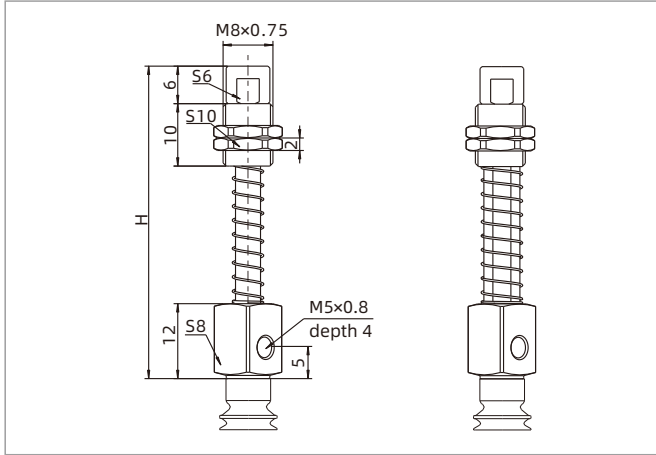

SP3B4-16 Lateral rotating

SP3B4-16 Lateral non-rotating

Model/Size	H	Buffer stroke	F1 N	F2 N	F3 N	Weight g
SP3B□-L15-M8	52.5	15	0.2	0.5	1.9	16.3
SP3B□-L15R-M8	52.5	15	0.2	0.5	1.8	15.5
SP3B□-L20-M8	59.5	20	0.2	0.5	1.8	15.1
SP3B□-L20R-M8	59.5	20	0.2	0.5	1.8	16.6

◇ Note: 1. Please refer to page 170 for suction cup selection  
 2. F1, F2, and F3 represent the elastic force of the buffer support rod at 0 stroke, 50% stroke, and 100% stroke

### Mounting parts - Level compensator

Model Vertical rotating	Vertical non-rotating	Model Lateral rotating	Lateral non-rotating	Buffer stroke	Applicable suction cup
PSP3-I3ST0.5-M6	PSP3-I3RST0.5-M8	PSP3-L3ST0.5-M6	PSP3-L3RST0.5-M8	3	SP3U1.5, 2, 3.5
PSP3-I6ST0.5-M6	PSP3-I6RST0.5-M8	PSP3-L6ST0.5-M6	PSP3-L6RST0.5-M8	6	
PSP3-I3ST1.5-M8	PSP3-I3RST1.5-M8	PSP3-L3ST1.5-M8	PSP3-L3RST1.5-M8	3	SP3C4, 6, 8; SP3B4, 6, 8
PSP3-I6ST1.5-M8	PSP3-I6RST1.5-M8	PSP3-L6ST1.5-M8	PSP3-L6RST1.5-M8	6	
PSP3-I10ST1.5-M8	PSP3-I10RST1.5-M8	PSP3-L10ST1.5-M8	PSP3-L10RST1.5-M8	10	
PSP3-I15ST1.5-M8	PSP3-I15RST1.5-M8	PSP3-L15ST1.5-M8	PSP3-L15RST1.5-M8	15	
PSP3-I20ST1.5-M8	PSP3-I20RST1.5-M8	PSP3-L20ST1.5-M8	PSP3-L20RST1.5-M8	20	
PSP3-I3ST2-M8	PSP3-I3RST2-M8	PSP3-L3ST2-M8	PSP3-L3RST2-M8	3	SP3C10, 13, 16; SP3B10, 13, 16
PSP3-I6ST2-M8	PSP3-I6RST2-M8	PSP3-L6ST2-M8	PSP3-L6RST2-M8	6	
PSP3-I10ST2-M8	PSP3-I10RST2-M8	PSP3-L10ST2-M8	PSP3-L10RST2-M8	10	
PSP3-I15ST2-M8	PSP3-I15RST2-M8	PSP3-L15ST2-M8	PSP3-L15RST2-M8	15	
PSP3-I20ST2-M8	PSP3-I20RST2-M8	PSP3-L20ST2-M8	PSP3-L20RST2-M8	20	

# SUF Series

## Small Flat Suction Cup



### Features

- ◇ Standard flat lip
- ◇ Small size, light weight

### Advantages

- ◇ Good airtightness, suitable for handling workpiece with smooth and even surface
- ◇ Suitable for handling small workpieces in electronic industry



### Applications

- ◇ Suitable for handling small workpieces, such as electronic components, sheet metal, solar wafer, etc.

### Structure

- ◇ Suction cup and fitting are split structure design, wearing parts can be replaced separately.

### How to order

SUF 3.5 N - M5M  
 ① ② ③ ④

① Series	② Diameter	③ Material & Hardness	④ Connection thread
SUF	3.5 - $\phi$ 3.5mm	N - NBR <span style="background-color: black; color: white; padding: 2px;">55</span>	Nil - Suction cup only
	5.5 - $\phi$ 5.5mm	S - Silicone <span style="background-color: red; color: white; padding: 2px;">50</span>	M5M - M5×0.8 male thread

### Selection

Model	Connection thread M - Male thread	MPQ pcs	Weight g
SUF3.5N    SUF3.5S	SUF3.5N-M5M    SUF3.5S-M5M	10	0.1
SUF5.5N    SUF5.5S	SUF5.5N-M5M    SUF3.5S-M5M	10	0.1

### Dimensions(mm)

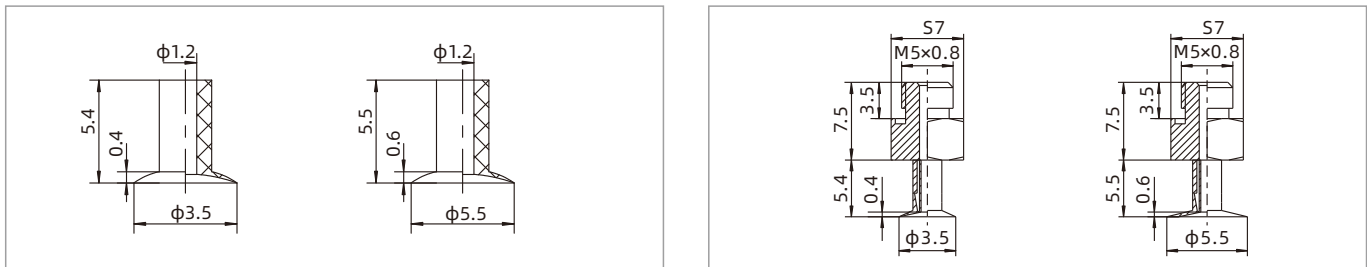

SUF3.5

SUF5.5

SUF3.5□-M5M

SUF5.5□-M5M

◇ Note: The dimensional tolerance conforms to GBT3672.1-2002-1 M3 rubber product dimensional tolerance standard

### Mounting parts

Item	Model	Applicable suction cup
Fitting for suction cup	PJS-M5M-SUF5.5	SUF3.5,5.5

SZ  
 SPH  
 SP3  
**SUF**  
 SAN  
 SAO  
 SOFA  
 STP  
 SFT  
 SFA  
 SBT  
 SBL  
 SBLP  
 SBS  
 SFP  
 SBP  
 SXP  
 SGP  
 SBOF  
 STC  
 SFF  
 SOB  
 SOF  
 SOG  
 SFM  
 SOM  
 SBF  
 SDM  
 SFU  
 SFK  
 SHT  
 SDL  
 SFG  
 SFGT  
 SFD  
 SB  
 SBA  
 SF  
 SU  
 SP2F  
 SPA  
 SPD  
 SPF  
 SPC  
 SPJ  
 SPU  
 SH  
 SHB  
 SBB  
 SOP  
 SNP

# SAN Series

## Nozzle Suction Cup



ELECTRONICS



### Features

- ◇ Nozzle design
- ◇ Small diameter
- ◇ Conductive material available

### Advantages

- ◇ Fast handling of mini type workpieces
- ◇ Ideal for occasions with limited space



### Applications

- ◇ Handling of mini type electronic components and thin sheet metal
- ◇ Handling of workpieces of small size and light weight
- ◇ Conductive material is suitable for electronic industry

### Structure

- ◇ Split structure for easy replacement of wearing parts

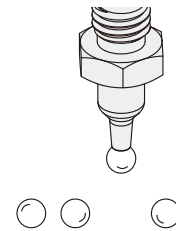

### How to order

## SAN 1.1 N - M5M

① ② ③ ④

① Series	② Diameter	③ Material & Hardness	④ Connection thread
SAN	0.8 - $\phi$ 0.8mm	N - NBR <span style="background-color: black; color: white; padding: 2px;">55</span>	Nil - Suction cup only
	1.1 - $\phi$ 1.1mm	WS - White silicone <span style="background-color: black; color: white; padding: 2px;">50</span>	M5M - M5x0.8 male thread
		CN - Conductive NBR <span style="background-color: black; color: white; padding: 2px;">55</span>	
		CS - Conductive silicone <span style="background-color: black; color: white; padding: 2px;">55</span>	

◇ Note: Min. package: 10pcs/bag

### Dimensions(mm)

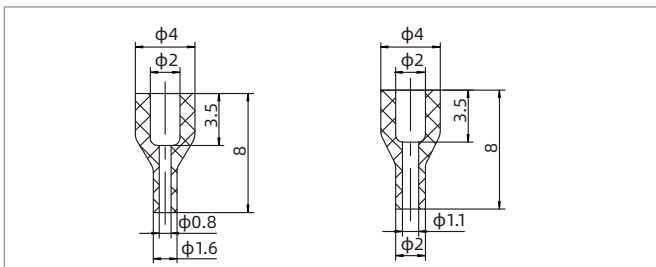

SAN0.8

SAN1.1

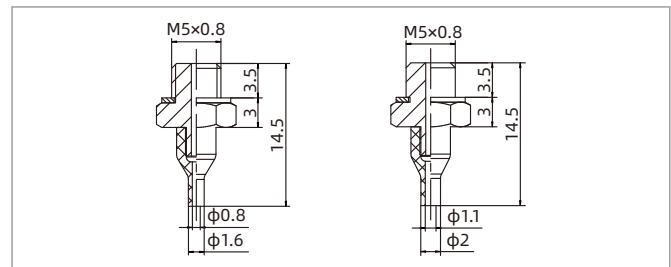

SAN0.8□-M5M

SAN1.1□-M5M

◇ Note: The dimensional tolerance conforms to the GB/T 3672.1-2002-1 M3 rubber product dimensional tolerance standard

### Mounting parts

Item	Model	Applicable suction cup
Fitting for suction cup	PJS-M5M-SAN1.1	SAN0.8, 1.1

# SAO Series

## Oval Flat Suction Cup



ELECTRONICS



### Features

- ◇ Oval and Flat structure
- ◇ Conductive material available
- ◇ Various sizes available

### Advantages

- ◇ Small sizes, large suction force, suitable for handling of long and narrow workpieces
- ◇ Discharge static electricity gently to protect workpieces from damage
- ◇ Suitable for workpieces of various sizes and shapes

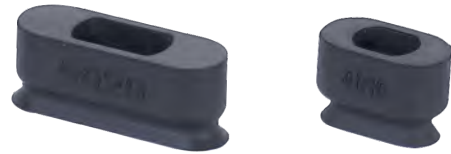

### Applications

- ◇ Handling of long and narrow workpieces with even surface
- ◇ Handling of electronic components
- ◇ Conductive material is suitable for 3C industry

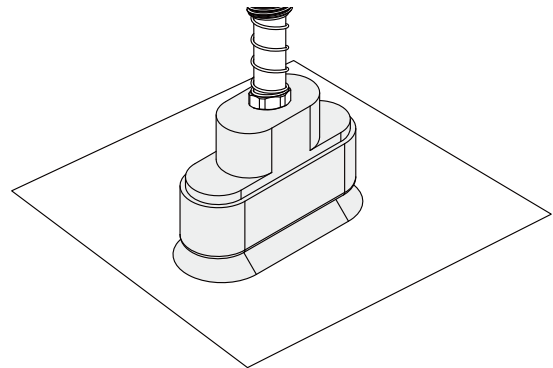

### Structure

- ◇ Split structure for easy replacement of wearing parts

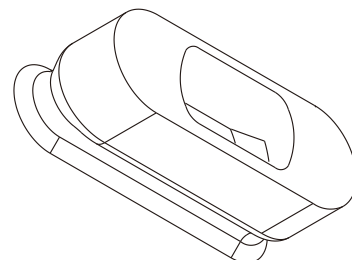

- SZ
- SPH
- SP3
- SUF
- SAN**
- SAO**
- SOFA
- STP
- SFT
- SFA
- SBT
- SBL
- SBLP
- SBS
- SFP
- SBP
- SXP
- SGP
- SBOF
- STC
- SFF
- SOB
- SOE
- SOG
- SFM
- SOM
- SBF
- SDM
- SFU
- SFK
- SHT
- SDL
- SFG
- SFGT
- SFD
- SB
- SBA
- SF
- SU
- SP2F
- SPA
- SPD
- SPF
- SPC
- SPJ
- SPU
- SH
- SHB
- SBB
- SOP
- SNP

# SAO Series

## Oval Flat Suction Cup

### How to order

## SAO 8x20 N

①                      ②                      ③

① Series	② Size	③ Material & Hardness
SAO	3.5x7    6x20	N - NBR                      55
	4x10    8x20	WS - White silicone        50
	5x10    4x30	CN - Conductive NBR       55
	6x10    5x30	CS - Conductive silicone   55
	4x20    6x30	
	5x20    8x30	

### Technical parameters

Model	Pull-out force N	Inner volume cm <sup>3</sup>	Min. Curve radius of workpiece mm	Weight g	Recommended hose dia. mm	MPQ pcs
SAO3.5x7	0.9	<0.1	6	0.5	4	10
SAO4x10	1.6	<0.1	7	0.4	4	10
SAO5x10	2	<0.1	9	0.4	4	10
SAO6x10	2.4	<0.1	13	0.5	4	10
SAO4x20	3.2	<0.1	8	0.8	4	10
SAO5x20	4.2	<0.1	11	0.7	4	10
SAO6x20	5	<0.1	14	0.9	4	10
SAO8x20	6.5	<0.1	16	0.9	4	10
SAO4x30	5.2	<0.1	8	1.3	4	10
SAO5x30	6.5	<0.1	10	1.1	4	10
SAO6x30	7.8	<0.1	14	1.2	4	10
SAO8x30	10.2	0.1	18	1.3	4	10

◇ Note: Testing vacuum level -60kPa, workpiece with smooth and clean surface. The data of pull-out force as above are figured out without considering safety factor. The data may be different according to different workpiece surfaces. Recommend the length of vacuum hose to be as short as possible, max 2m.

### Dimensions(mm)

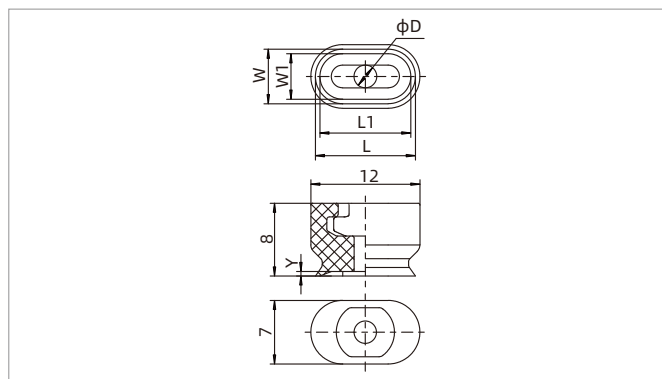

Model/Size	W	L	W1	L1	D	Y
SAO3.5x7 □	4.5	8	3.5	7	2-1.5	0.5
SAO4x10 □	5	11	4	10	2-1.5	0.5
SAO5x10 □	6	11	5	10	2.5	0.5
SAO6x10 □	7	11	6	10	2.5	0.5

SAO

# SAO Series

## Oval Flat Suction Cup

### Dimensions(mm)

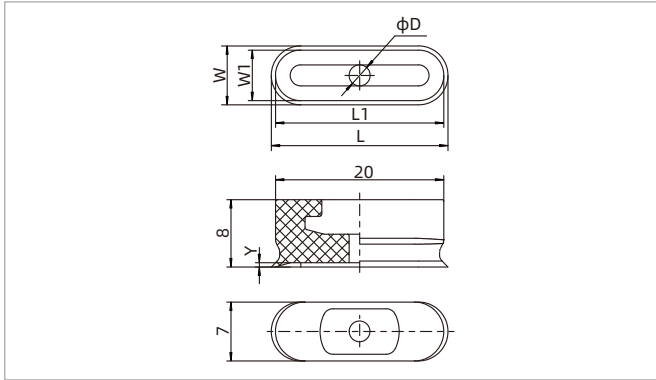

SAO

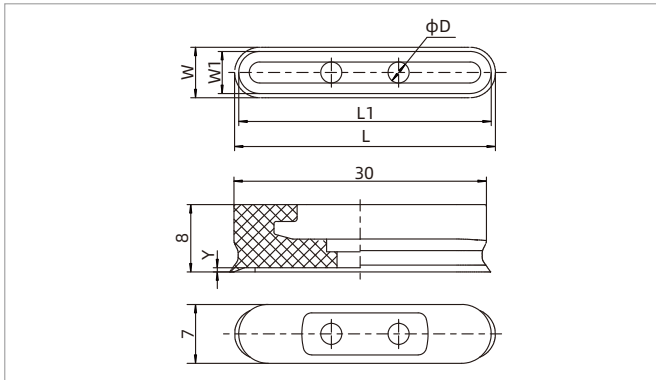

SAO

◇ Note: The dimensional tolerance conforms to the GB/T 3672.1-2002-1 M3 rubber product dimensional tolerance standard

Model/Size	W	L	W1	L1	D	Y
SAO4×20□	5	21	4	20	2-1.8	0.5
SAO5×20□	6	21	5	20	2-2	0.5
SAO6×20□	7	21	6	20	2.5	0.5
SAO8×20□	9	21	8	20	3	0.8

Model/Size	W	L	W1	L1	D	Y
SAO4×30□	5	31	4	30	2-1.8	0.5
SAO5×30□	6	31	5	30	2-2.5	0.5
SAO6×30□	7	31	6	30	2-2.5	0.5
SAO8×30□	9	31	8	30	2-2.5	0.8

- SAO
- SOFA
- STP
- SFT
- SFA
- SBT
- SBL
- SBLP
- SBS
- SFP
- SBP
- SXP
- SGP
- SBOF
- STC
- SFF
- SOB
- SOF
- SOG
- SFM
- SOM
- SBF
- SDM
- SFU
- SFK
- SHT
- SDL
- SFG
- SFGT
- SFD
- SB
- SBA
- SF
- SU
- SP2F
- SPA
- SPD
- SPF
- SPC
- SPJ
- SPU
- SH
- SHB
- SBB
- SOP
- SNP

# SAO Series

## Suction Cup with Locking Fitting



### Structure

- ◇ Consisting of replacement suction cup and locking fitting
- ◇ Plug-in fitting for suction cup
- ◇ Vertical vacuum port, female thread for mounting
- ◇ Lateral vacuum port, male and female thread for mounting

In the same series, replacement suction cup and locking fitting can be combined as required

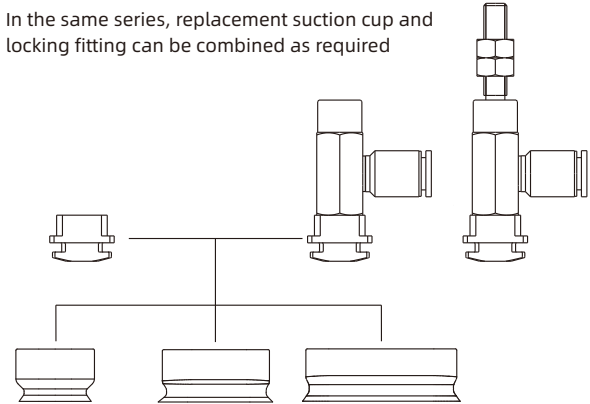

### How to order

## SAO5×20N - LA6 - M5F

①

②

③

① Model	② Vacuum port direction	③ Mounting thread
SAO5×20N	Nil - Vertical LA4 - Lateral, one-touch fitting φ4 hose LA6 - Lateral, one-touch fitting φ6 hose	M5M - M5×0.8 male thread M5F - M5×0.8 female thread

◇ Please refer to page 186 for suction cup selection

### Selection

Connection thread M - Male thread		F - Female thread		
SAO3.5×7□-LA4-M5M	SAO3.5×7□-LA6-M5M	SAO3.5×7□-LA4-M5F	SAO3.5×7□-LA6-M5F	SAO3.5×7□-M5F
SAO4×10□-LA4-M5M	SAO4×10□-LA6-M5M	SAO4×10□-LA4-M5F	SAO4×10□-LA6-M5F	SAO4×10□-M5F
SAO5×10□-LA4-M5M	SAO5×10□-LA6-M5M	SAO5×10□-LA4-M5F	SAO5×10□-LA6-M5F	SAO5×10□-M5F
SAO6×10□-LA4-M5M	SAO6×10□-LA6-M5M	SAO6×10□-LA4-M5F	SAO6×10□-LA6-M5F	SAO6×10□-M5F
SAO4×20□-LA4-M5M	SAO4×20□-LA6-M5M	SAO4×20□-LA4-M5F	SAO4×20□-LA6-M5F	SAO4×20□-M5F
SAO5×20□-LA4-M5M	SAO5×20□-LA6-M5M	SAO5×20□-LA4-M5F	SAO5×20□-LA6-M5F	SAO5×20□-M5F
SAO6×20□-LA4-M5M	SAO6×20□-LA6-M5M	SAO6×20□-LA4-M5F	SAO6×20□-LA6-M5F	SAO6×20□-M5F
SAO8×20□-LA4-M5M	SAO8×20□-LA6-M5M	SAO8×20□-LA4-M5F	SAO8×20□-LA6-M5F	SAO8×20□-M5F
SAO4×30□-LA4-M5M	SAO4×30□-LA6-M5M	SAO4×30□-LA4-M5F	SAO4×30□-LA6-M5F	SAO4×30□-M5F
SAO5×30□-LA4-M5M	SAO5×30□-LA6-M5M	SAO5×30□-LA4-M5F	SAO5×30□-LA6-M5F	SAO5×30□-M5F
SAO6×30□-LA4-M5M	SAO6×30□-LA6-M5M	SAO6×30□-LA4-M5F	SAO6×30□-LA6-M5F	SAO6×30□-M5F
SAO8×30□-LA4-M5M	SAO8×30□-LA6-M5M	SAO8×30□-LA4-M5F	SAO8×30□-LA6-M5F	SAO8×30□-M5F

# SAO Series

## Suction Cup with Locking Fitting



### Dimensions(mm)

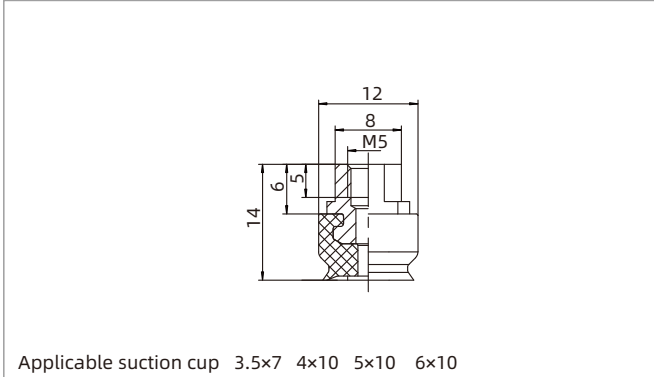

Vertical-Female thread connection

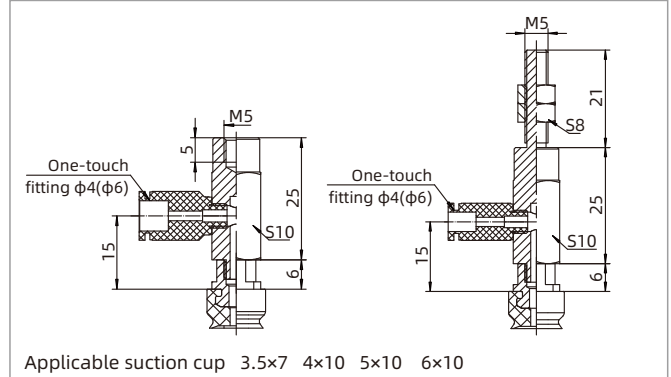

Lateral-Female thread connection Lateral-Male thread connection

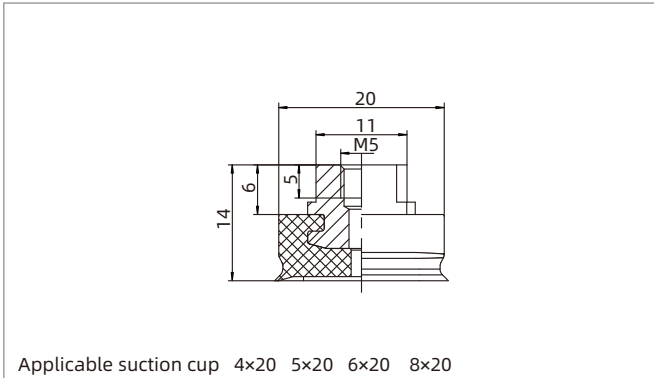

Vertical-Female thread connection

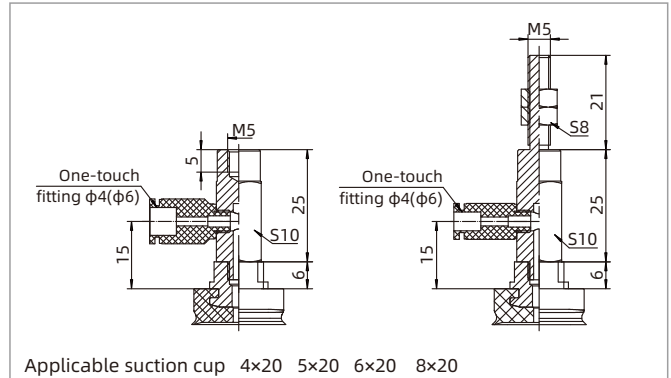

Lateral-Female thread connection Lateral-Male thread connection

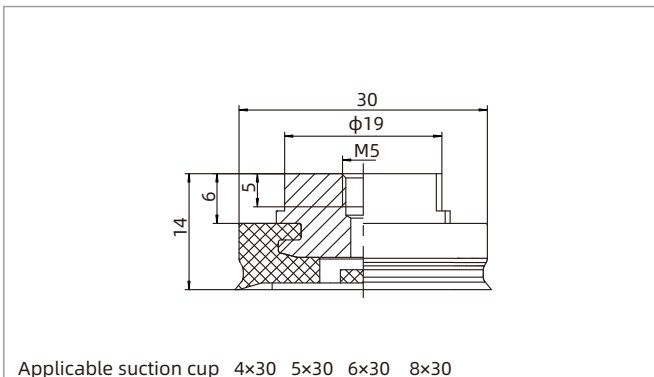

Vertical-Female thread connection

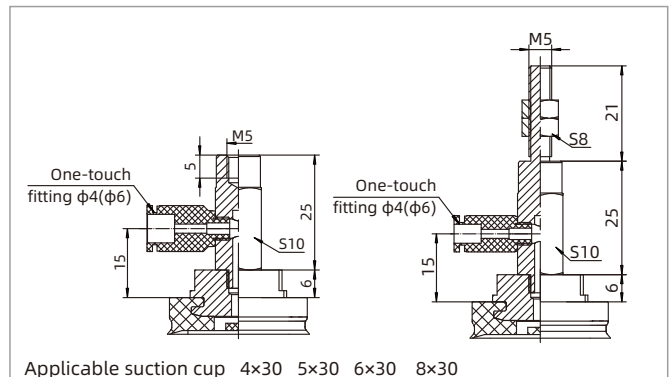

Lateral-Female thread connection Lateral-Male thread connection

- SZ
- SPH
- SP3
- SUF
- SAN
- SAO**
- SOFA
- STP
- SFT
- SFA
- SBT
- SBL
- SBLP
- SBS
- SFP
- SBP
- SXP
- SGP
- SBOF
- STC
- SFF
- SOB
- SOF
- SOG
- SFM
- SOM
- SBF
- SDM
- SFU
- SFK
- SHT
- SDL
- SFG
- SFGT
- SFD
- SB
- SBA
- SF
- SU
- SP2F
- SPA
- SPD
- SPF
- SPC
- SPJ
- SPU
- SH
- SHB
- SBB
- SOP
- SNP

# SAO Series

## Suction Cup with Level Compensator

### Structure

- ◇ Consisting of replacement suction cup(3) and level compensator
- ◇ Plug-in fitting for suction cup
- ◇ Vertical vacuum port(1), male thread for mounting
- ◇ Lateral vacuum port(2), male thread for mounting

In the same series, replacement suction cup and level compensator can be combined as required

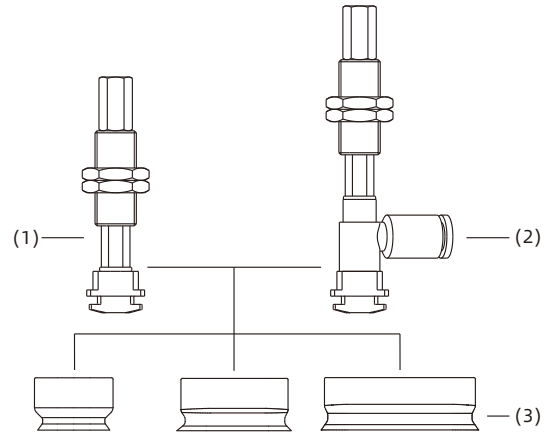

### How to order

**SAO5×20N - E | 10 R A6 - M10**

①                      ②   ③   ④   ⑤   ⑥                      ⑦

① Series	② Level compensator type	③ Buffer type	④ Buffer stroke	⑤ Rotary type	⑥ Vacuum port connection	⑦ Mounting thread
SAO5×20N	E - PSPE Series	I - Internal spring	10    40 20    50 30	R - Vertical non-rotating B - Lateral non-rotating	Nil - M5×0.8 female thread A4 - One-touch fitting φ4 hose A6 - One-touch fitting φ6 hose	M10 - M10×1

◇ Please refer to page 186 for suction cup selection

### Selection

Rotary type/ Vacuum port connection	Nil	A4	A6
R - Vertical non-rotating	●	●	●
B - Lateral non-rotating	-	●	●

◇ Note: "●" default, in stock, "-" unavailable

# SAO Series

## Suction Cup with Level Compensator

### Dimensions(mm)

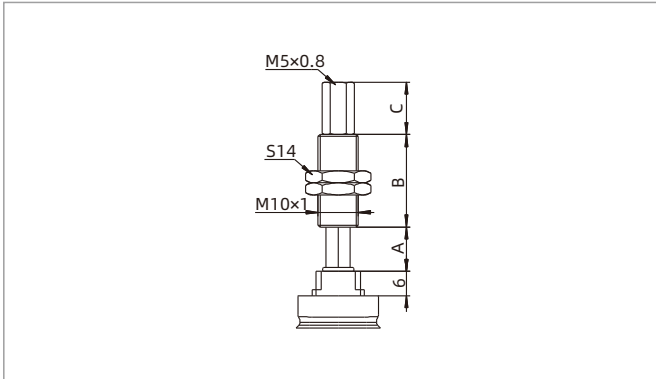

Vertical-Female thread connection

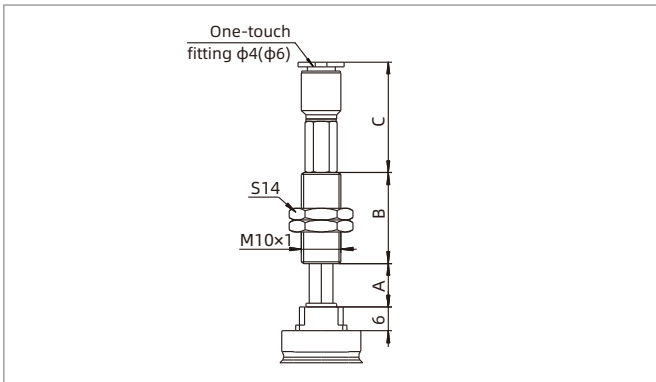

Vertical-One-touch fitting

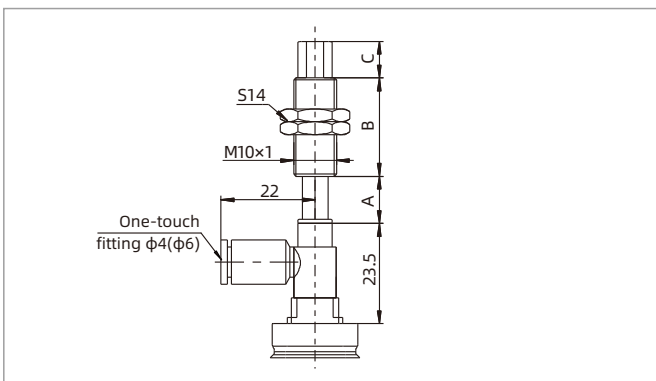

Lateral-One-touch fitting

Model/Size	A	B	C	Buffer stroke	F1 (N)	F2 (N)
SAO□-EI10R-M10	11	23	13	10	1.0	3.0
SAO□-EI20R-M10	21	51	13	20	1.0	3.0
SAO□-EI30R-M10	31	51	13	30	1.0	3.0
SAO□-EI40R-M10	41	77	13	40	1.0	3.0
SAO□-EI50R-M10	51	77	13	50	1.0	3.0

Model/Size	A	B	C	Buffer stroke	F1 (N)	F2 (N)
SAO□-EI10R□-M10	11	23	28	10	1.0	3.0
SAO□-EI20R□-M10	21	51	28	20	1.0	3.0
SAO□-EI30R□-M10	31	51	28	30	1.0	3.0
SAO□-EI40R□-M10	41	77	28	40	1.0	3.0
SAO□-EI50R□-M10	51	77	28	50	1.0	3.0

Model/Size	A	B	C	Buffer stroke	F1 (N)	F2 (N)
SAO□-EI10B□-M10	11	23	8.5	10	1.0	3.0
SAO□-EI20B□-M10	21	51	8.5	20	1.0	3.0
SAO□-EI30B□-M10	31	51	8.5	30	1.0	3.0
SAO□-EI40B□-M10	41	77	8.5	40	1.0	3.0
SAO□-EI50B□-M10	51	77	8.5	50	1.0	3.0

◇ Note: 1. Please refer to page 186 for suction cup selection  
 2. "F1" means spring force at 0 stroke, "F2" means spring force at max. Stroke

- SZ
- SPH
- SP3
- SUF
- SAN
- SAO**
- SOFA
- STP
- SFT
- SFA
- SBT
- SBL
- SBLP
- SBS
- SFP
- SBP
- SXP
- SGP
- SBOF
- STC
- SFF
- SOB
- SOF
- SOG
- SFM
- SOM
- SBF
- SDM
- SFU
- SFK
- SHT
- SDL
- SFG
- SFGT
- SFD
- SB
- SBA
- SF
- SU
- SP2F
- SPA
- SPD
- SPF
- SPC
- SPJ
- SPU
- SH
- SHB
- SBB
- SOP
- SNP

# SOFA Series

## Oval Flat Suction Cup



### Features

- ◇ Oval Flat suction cup

### Advantages

- ◇ Handling long and narrow workpieces or flat workpieces with reinforced rib on surface
- ◇ Small size, light weight

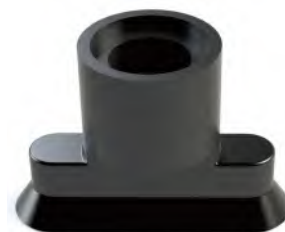

### Applications

- ◇ Handling small, long and narrow workpieces
- ◇ Electronic products

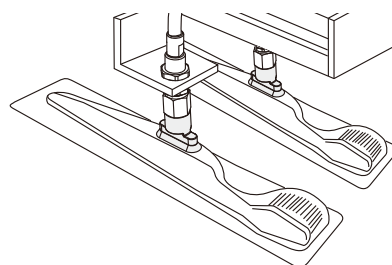

### How to order

SOFA 6×18 N - M5F

①      ②      ③      ④

① Series	② Size	③ Material & Hardness	④ Connection thread
SOFA	6×18	N - NBR <span style="background-color: black; color: white; padding: 2px;">55</span> WS - White silicone <span style="border: 1px solid black; padding: 2px;">50</span>	Nil - Suction cup only M5F - M5×0.8 female thread

- ◇ Min package: 10pcs

### Dimensions(mm)

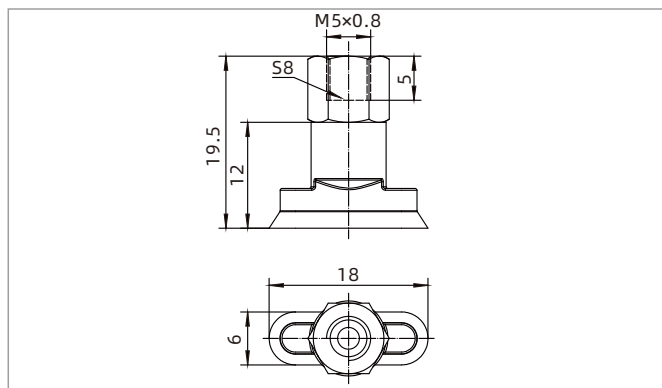

SOFA6x18-M5F

- ◇ Note: The dimensional tolerance conforms to GB/T3672.1-2002-1 M3 rubber product dimensional tolerance standard

# STP Series

## Ultra-thin Flower-shaped Suction Cup

**AIRBEST**



PLASTIC BAG



HIGH SEALING



Suction Cup

### Features

- ◇ Ultra-thin soft sealing lip design
- ◇ Double reinforced rib structure
- ◇ Food grade POM and silicone
- ◇ Lateral air ports are evenly distributed
- ◇ Two sizes and two hardness are optional

### Advantages

- ◇ Optimal sealing, good for fitting different soft packing bags
- ◇ Effectively enhance suction cup strength, ensure maximum grasping capacity
- ◇ Can be used for food package handling
- ◇ Prevent soft package from deformation during grabbing and blocking the air port
- ◇ 35 degrees white silicone is suitable for softer bags, 50 degrees blue silicone is suitable for harder bags



### Applications

- ◇ Suitable for handling soft packaging plastic bags, such as bags of washing powder, detergent, tissue, express bags, etc.
- ◇ Food grade silicone can be used in food industry, such as bag of milk, bread, puffed food, etc.

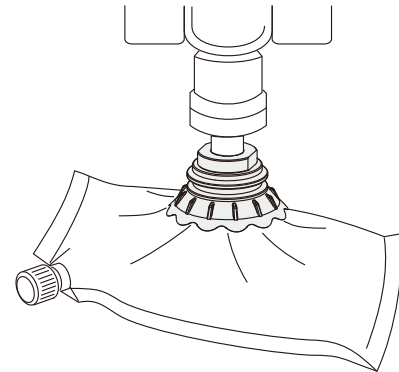

### Structure

- ◇ STP35 is 2.5 bellows and with large compressed stroke
- ◇ Suction cup and fitting are split structure design, wearing parts can be replaced separately

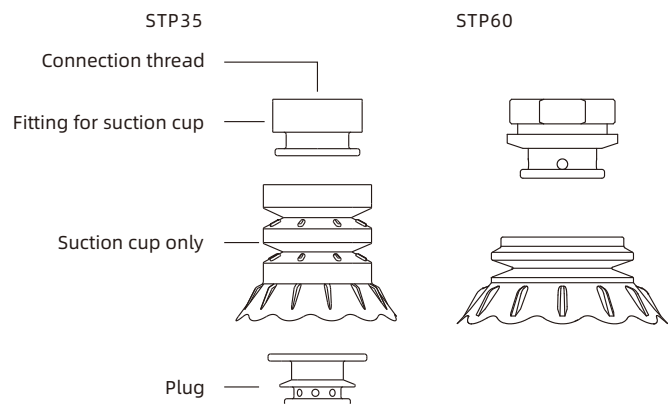

SZ  
SPH  
SP3  
SUF  
SAN  
SAO  
SOFA  
STP  
SFT  
SFA  
SBT  
SBL  
SBLP  
SBS  
SFP  
SBP  
SXP  
SGP  
SBOF  
STC  
SFF  
SOB  
SOF  
SOG  
SFM  
SOM  
SBF  
SDM  
SFU  
SFK  
SHT  
SDL  
SFG  
SFGT  
SFD  
SB  
SBA  
SF  
SU  
SP2F  
SPA  
SPD  
SPF  
SPC  
SPJ  
SPU  
SH  
SHB  
SBB  
SOP  
SNP

# STP Series

## Ultra-thin Flower-shaped Suction Cup

### How to order

STP 60 S - G3F  
 ① ② ③ ④

① Series	② Diameter	③ Material & Hardness	④ Connection thread
STP	35 - $\phi$ 35mm	S - Silicone <span style="border: 1px solid black; padding: 0 2px;">50</span>	G2F - G1/4 female thread
	60 - $\phi$ 60mm	WS - White silicone <span style="border: 1px solid black; padding: 0 2px;">35</span>	G3F - G3/8 female thread

### Selection

Model	Material S		MPQ pcs	Weight g
	S	WS		
STP35	STP35S-G2F	STP35WS-G2F	1	5
STP60	STP60S-G3F	STP60WS-G3F	1	9

### Dimensions(mm)

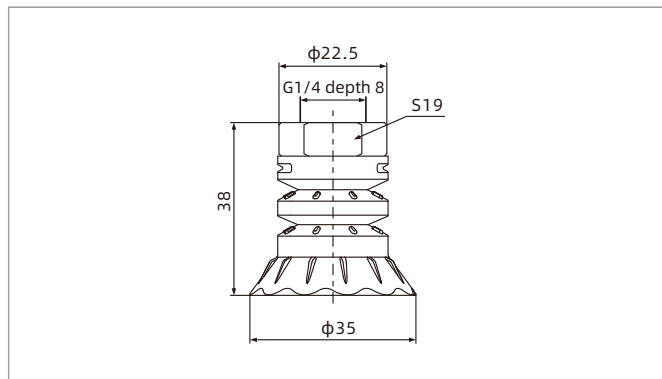

STP35□-G2F

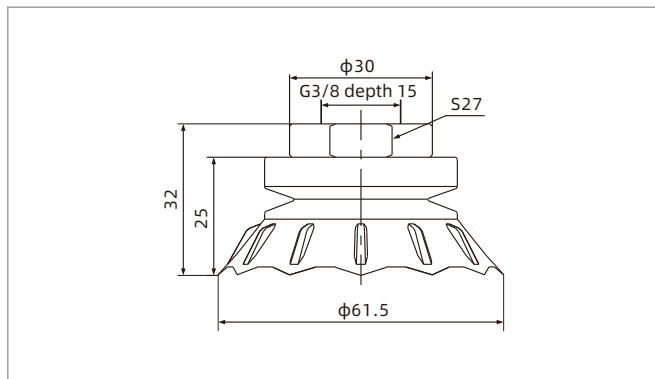

STP60□-G3F

◇Note: The dimensional tolerance conforms to GB/T3672.1-2002-1 M3 rubber product dimensional tolerance standard

# SFT Series

## Thin Lip Flat Suction Cup



PAPER



PLASTIC BAG



GLASS



SOLAR



COMPOSITE MATERIAL



ANTI-DEFORMATION



### Features

- ◇ Ultra-thin sealing lip
- ◇ High temperature and mark free material is optional

### Advantages

- ◇ Suitable for film, paper and solar panels
- ◇ Prevent the workpiece from being sucked into the suction cup
- ◇ Suction without mark, can also for high temperature and mark free
- ◇ Prevent paper and film from wrinkling
- ◇ High temperature resistance, ozone resistance and UV radiation, suitable for handling in paper and printing industry



### Applications

- ◇ Handling all kinds of packaging materials, such as paper, plastic film, opening plastic bag
- ◇ Handling fragile workpieces, such as thin wooden panels, solar silicon wafers, solar cell

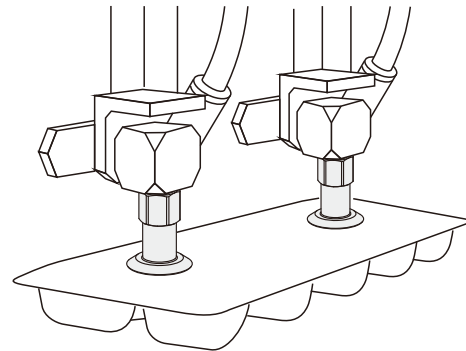

### Structure

- ◇ Suction cup and fitting are split structure design, wearing parts can be replaced separately

In same series, replacement suction cup and fitting can be combined on request.

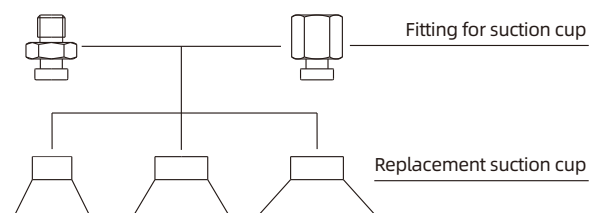

- SZ
- SPH
- SP3
- SUF
- SAN
- SAO
- SOFA
- STP
- SFT**
- SFA
- SBT
- SBL
- SBLP
- SBS
- SFP
- SBP
- SXP
- SGP
- SBOF
- STC
- SFF
- SOB
- SOE
- SOG
- SFM
- SOM
- SBF
- SDM
- SFU
- SFK
- SHT
- SDL
- SFG
- SFGT
- SFD
- SB
- SBA
- SF
- SU
- SP2F
- SPA
- SPD
- SPF
- SPC
- SPJ
- SPU
- SH
- SHB
- SBB
- SOP
- SNP

# SFT Series

## Thin Lip Flat Suction Cup

### How to order

## SFT 15 HD - M5M

①      ②      ③      ④

① Series	② Diameter	③ Material & Hardness	④ Connection thread
SFT	15 - $\phi$ 15mm	WS - White silicone	50 Nil - Suction cup only
	20 - $\phi$ 20mm	HD - High temp/ Mark free material	60 M5M - M5x0.8 male thread
	24 - $\phi$ 24mm	NR - Natural rubber	40 G1M - G1/8 male thread
	30 - $\phi$ 30mm		G2M - G1/4 male thread
	34 - $\phi$ 34mm		G1F - G1/8 female thread
	35 - $\phi$ 35mm		G2F - G1/4 female thread
	40 - $\phi$ 40mm		

### Selection

Model	Connection thread	
	M - Male thread	F - Female thread
SFT15□	SFT15□-M5M    SFT15□-G1M	SFT15□-G1F
SFT20□	SFT20□-M5M    SFT20□-G1M	SFT20□-G1F
SFT24□	SFT24□-M5M    SFT24□-G1M	SFT24□-G1F
SFT30□	SFT30□-G2M	SFT30□-G2F
SFT34□	SFT34□-G2M	SFT34□-G2F
SFT35□	SFT35□-G2M	SFT35□-G2F
SFT40□	SFT40□-G2M	SFT40□-G2F

### Technical parameters

Model	Pull-out force N	Inner volume cm <sup>3</sup>	Min.curve radius of workpiece mm	Weight g	Recommended hose dia. mm	MPQ pcs
SFT15	8	0.2	16	0.5	6	10
SFT20	14	0.5	18	0.8	6	5
SFT24	20	0.7	23	1	6	5
SFT30	32	1.3	28	2.7	8	5
SFT34	41	2	33	3.1	8	5
SFT35	43	1.5	19	5.8	8	5
SFT40	56.5	3	39	4.5	8	5

◇ Note: Testing vacuum level -60kPa, workpiece with smooth and clean surface. The data of pull-out force as above are figured out without considering safety factor. The data may be different according to different workpiece surfaces. Recommend the length of vacuum hose to be as short as possible, max 2m.

# SFT Series

## Thin Lip Flat Suction Cup

### Dimensions(mm) - Suction cup only

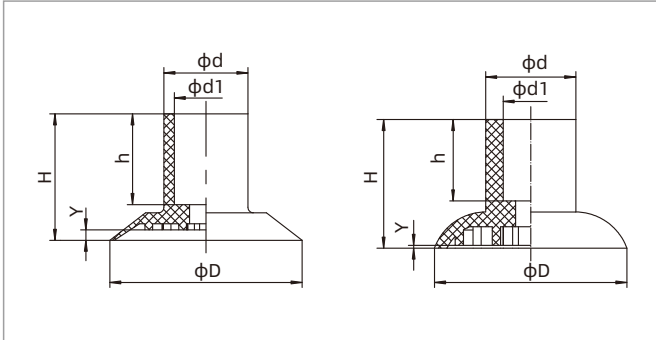

SFT15-40

SFT35

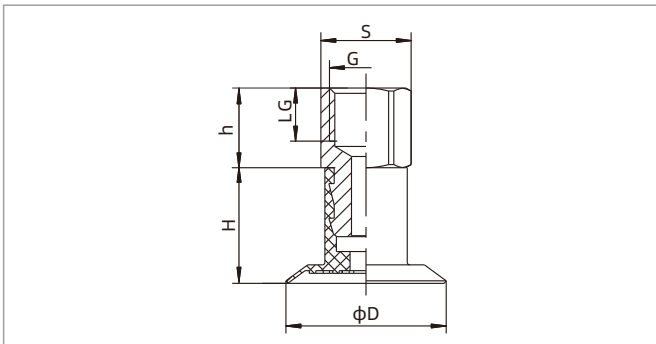

SFT - Female thread connection

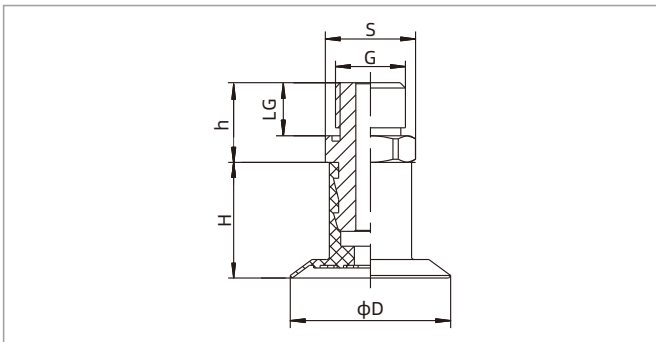

SFT - Male thread connection

Model/Size	D	H	d	h	d1	Y
SFT15□	14.5	10	9	7.2	4.5	0.9
SFT20□	20.9	10.4	10.5	7.2	4.5	1.5
SFT24□	24.4	10.8	10	7.2	4.5	1.7
SFT30□	30.6	21.8	15.6	15.7	11.2	2
SFT34□	34.5	23	14.8	16.8	11.2	1.4
SFT35□	35	23.5	16.5	14.8	10	0.5
SFT40□	40.5	20.5	16	14.5	8	2.3

Model/Size	D	H	h	G	LG	S
SFT15□-G1F	14.5	10	12	G1/8	8	14
SFT20□-G1F	20.9	10.4	12	G1/8	8	14
SFT24□-G1F	24.4	10.8	12	G1/8	8	14
SFT30□-G2F	30.6	21.8	15	G1/4	10	17
SFT34□-G2F	34.5	23	15	G1/4	10	17
SFT35□-G2F	35	23.5	15	G1/4	10	17
SFT40□-G2F	40.5	20.5	15	G1/4	10	17

Model/Size	D	H	h	G	LG	S
SFT15□-M5M	14.5	10	10	M5×0.8	5	7
SFT15□-G1M	14.5	10	13.5	G1/8	7.5	14
SFT20□-M5M	20.9	10.4	10	M5×0.8	5	7
SFT20□-G1M	20.9	10.4	13.5	G1/8	7.5	14
SFT24□-M5M	24.4	10.8	10	M5×0.8	5	7
SFT24□-G1M	24.4	10.8	13.5	G1/8	7.5	14
SFT30□-G2M	30.6	21.8	15	G1/4	10	17
SFT34□-G2M	34.5	23	15	G1/4	10	17
SFT35□-G2M	35	23.5	15	G1/4	10	17
SFT40□-G2M	40.5	20.5	15	G1/4	10	17

◇ Note: The dimensional tolerance conforms to GBT3672.1-2002-1 M3 rubber product dimensional tolerance standard

### Mounting parts

Item	Model M - Male thread	F - Female thread	Applicable suction cup
Fitting for suction cup	PJS-M5M-SFT24	-	SFT15, 20, 24
	PJS-G1M-SFT24	PJS-G1F-SFT24	SFT15, 20, 24
	PJS-G2M-SFT34	PJS-G2F-SFT34	SFT30, 34
	PJS-G2M-SFT35	PJS-G2F-SFT35	SFT35
	PJS-G2M-SFT40	PJS-G2F-SFT40	SFT40

- SZ
- SPH
- SP3
- SUF
- SAN
- SAO
- SOFA
- STP
- SFT**
- SFA
- SBT
- SBL
- SBLP
- SBS
- SFP
- SBP
- SXP
- SGP
- SBOF
- STC
- SFF
- SOB
- SOF
- SOG
- SFM
- SOM
- SBF
- SDM
- SFU
- SFK
- SHT
- SDL
- SFG
- SFGT
- SFD
- SB
- SBA
- SF
- SU
- SP2F
- SPA
- SPD
- SPF
- SPC
- SPJ
- SPU
- SH
- SHB
- SBB
- SOP
- SNP

# SFA Series

## Ultra-thin Lip Flat Suction Cup Special for Plastic Bags



PLASTIC BAG



HIGH SEALING



### Features

- ◇ Ultra-thin sealing lip
- ◇ Support structure at the bottom

### Advantages

- ◇ Suitable for film products, can fit workpiece closely
- ◇ Prevent the workpiece from being sucked into suction cup and wrinkling
- ◇ Food grade silicone, suitable for food package



### Applications

- ◇ Handling plastic film packaging bag
- ◇ Open film packaging bag in packaging production line

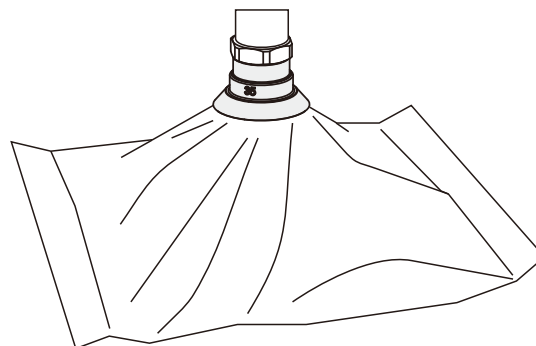

### Structure

- ◇ Suction cup and fitting are split structure design, wearing parts can be replaced separately

In same series, replacement suction cup and fitting can be combined on request.

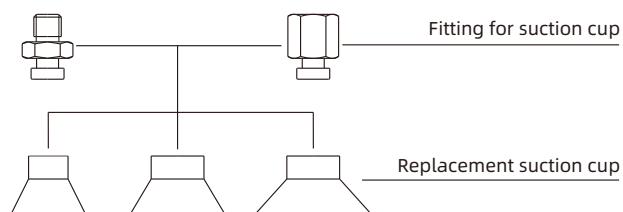

# SFA Series

Ultra-thin Lip Flat Suction Cup Special for Plastic Bags

## How to order

### SFA 20 S - M5M

① ② ③ ④

① Series	② Diameter	③ Material & Hardness	④ Connection thread
SFA	20 - $\phi$ 20mm 25 - $\phi$ 25mm 35 - $\phi$ 35mm 50 - $\phi$ 50mm	S - Silicone <b>40</b>	Nil - Suction cup only M5M - M5x0.8 male thread    M5F - M5x0.8 female thread G1M - G1/8 male thread        M8F - M8x1.25 female thread G2M - G1/4 male thread G3M - G3/8 male thread

## Selection

Model	Connection thread M - Male thread		F - Female thread	MPQ pcs
SFA20S	SFA20S-M5M	SFA20S-G1M	SFA20S-M5F	5
SFA25S	SFA25S-M5M	SFA25S-G1M	SFA25S-M5F	5
SFA35S	SFA35S-G2M	SFA35S-G3M	SFA35S-M8F	5
SFA50S	SFA50S-G2M	SFA50S-G3M	SFA50S-M8F	1

## Dimensions(mm) - Suction cup only

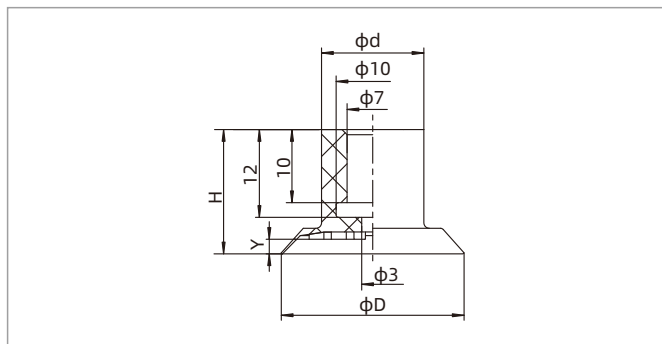

SFA20-25

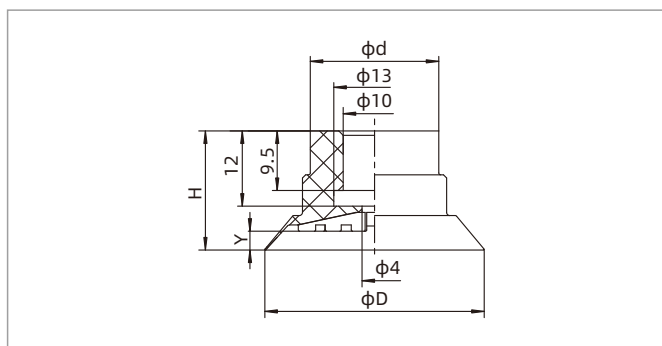

SFA35-50

Model/Size	D	H	d	Y
SFA20S	20	17	13	1.6
SFA25S	25	17	14	2

Model/Size	D	H	d	Y
SFA35S	35	19	20.5	3
SFA50S	50	22	20.5	4.5

# SFA Series



## Ultra-thin Lip Flat Suction Cup Special for Plastic Bags

### Dimensions(mm) - Suction cup with fitting

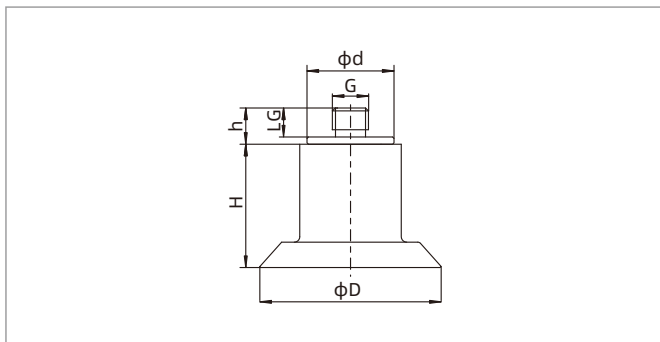

SFA - Male thread connection

Model/Size	D	H	h	G	LG	d
SFA20S-M5M	20	17	5	M5×0.8	4	12
SFA25S-M5M	25	17	5	M5×0.8	4	12

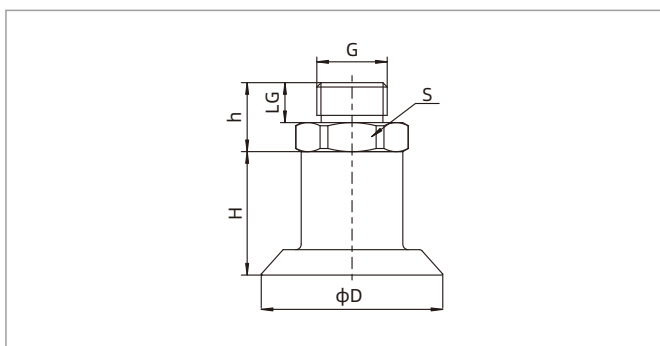

SFA - Male thread connection

Model/Size	D	H	h	G	LG	S
SFA20S-G1M	20	17	9.5	G1/8	5.5	14
SFA25S-G1M	25	17	9.5	G1/8	5.5	14
SFA35S-G2M	35	19	11.5	G1/4	6.5	21
SFA35S-G3M	35	19	11.5	G3/8	6.5	21
SFA50S-G2M	50	22	11.5	G1/4	6.5	21
SFA50S-G3M	50	22	11.5	G3/8	6.5	21

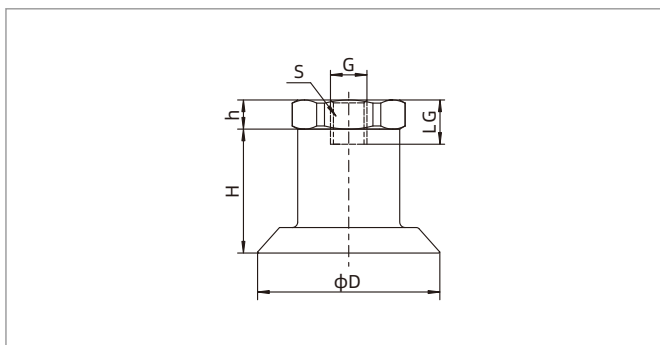

SFA - Female thread connection

Model/Size	D	H	h	G	LG	S
SFA20S-M5F	20	17	4	M5×0.8	5	14
SFA25S-M5F	25	17	4	M5×0.8	5	14
SFA35S-M8F	35	19	6	M8×1.25	8	21
SFA50S-M8F	50	22	6	M8×1.25	8	21

◇ Note: The dimensional tolerance conforms to GB/T3672.1-2002-1 M3 rubber product dimensional tolerance standard

### Mounting parts

Item	Model M - Male thread	F - Female thread	Applicable suction cup
Fitting for suction cup	PJS-M5M-SFA20	PJS-M5F-SFA20	SFA20,25
	PJS-G1M-SFA20	-	SFA20,25
	PJS-G2M-SFA50	PJS-M8F-SFA50	SFA35,50
	PJS-G3M-SFA50	-	SFA35,50

# SBT Series

## Bellows Suction Cup Special for Thin Workpieces

**AIRBEST**



PACKAGING



ANTI-DEFORMATION



Suction Cup

### Features

- ◇ Designed with slightly curved bottom and distributed holes avoiding permanent deformation of thin workpieces
- ◇ 1.5 bellows has certain buffer effect
- ◇ Split structure for easy replacement of wearing parts

### Applications

- ◇ Thin film objects such as aluminum foil and silver paper, etc.



### How to order

**SBT 16 N - M5F**

①      ②      ③      ④

① Series	② Diameter	③ Material&Hardness	④ Connection thread
SBT	16 - $\phi$ 16mm	N - NBR <span style="border: 1px solid black; padding: 0 2px;">40</span> WS - White silicone <span style="border: 1px solid black; padding: 0 2px;">30</span>	Nil - Suction cup only M5F - M5x0.8 female thread M5M - M5x0.8 male thread

### Technical parameters

Model	Pull-out force (N)	Inner volume $\text{cm}^3$	Weight g
SBT16	8	< 0.1	1.3

### Dimensions (mm)

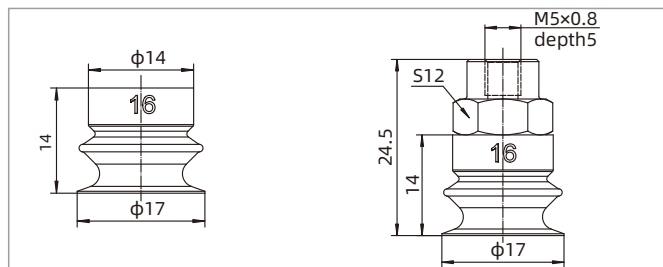

SBT16

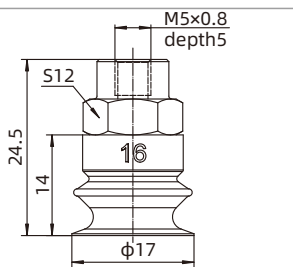

SBT16-M5F

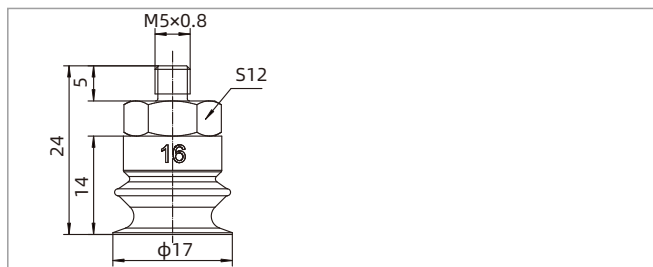

SBT16-M5M

SZ  
SPH  
SP3  
SUF  
SAN  
SAO  
SOFA  
STP  
SFT  
SFA  
SBT  
SBL  
SBLP  
SBS  
SFP  
SBP  
SXP  
SGP  
SBOF  
STC  
SFF  
SOB  
SOF  
SOG  
SFM  
SOM  
SBF  
SDM  
SFU  
SFK  
SHT  
SDL  
SFG  
SFGT  
SFD  
SB  
SBA  
SF  
SU  
SP2F  
SPA  
SPD  
SPF  
SPC  
SPJ  
SPU  
SH  
SHB  
SBB  
SOP  
SNP

# SBL Series

## 4.5 Bellows Suction Cup

**AIRBEST**



FOOD  
PACKAGING



PLASTIC BAG



FDA



### Features

- ◇ 4.5 Bellows
- ◇ Thin sealing lip
- ◇ Food grade silicone

### Advantages

- ◇ Suitable for handling workpieces with irregular shape
- ◇ Grabbing soft package with good airtightness
- ◇ Direct contact with food



### Applications

- ◇ Handling very soft products, such as plastic bags, aluminum foil bags, etc
- ◇ Handling fragile products, such as glass, egg, etc
- ◇ Handling food, such as bread, biscuits, etc
- ◇ Grabbing package bags containing solid products, powder or liquid safely

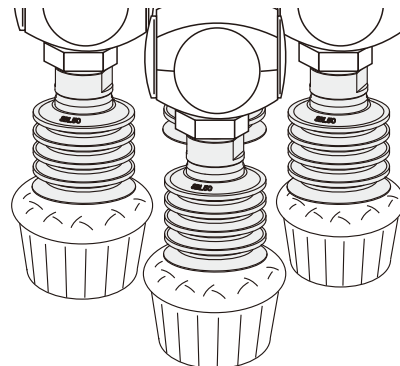

### Structure

- ◇ Multiple bellows, large compressed stroke
- ◇ Suction cup and fitting are split structure design, wearing parts can be replaced separately

In same series, replacement suction cup and fitting can be combined on request.

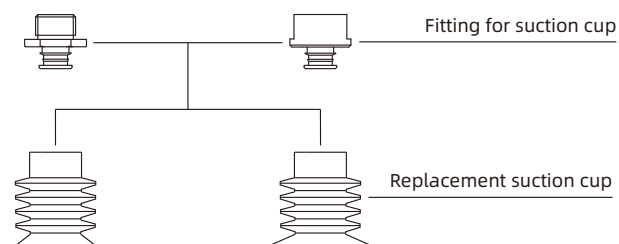

# SBL Series

## 4.5 Bellows Suction Cup

### How to order

## SBL 15 S - M5M

①      ②      ③      ④

① Series	② Diameter	③ Material & Hardness	④ Connection thread
SBL	15 - $\phi$ 15mm	N - NBR <span style="background-color: black; color: white; padding: 2px;">55</span>	Nil - Suction cup only      M5M - M5x0.8 male thread
	20 - $\phi$ 20mm	S - Silicone <span style="background-color: red; color: white; padding: 2px;">50</span>	G1F - G1/8 female thread      G1M - G1/8 male thread
	30 - $\phi$ 30mm	WS - White silicone <span style="border: 1px solid black; padding: 2px;">50</span>	G2F - G1/4 female thread      G2M - G1/4 male thread
	40 - $\phi$ 40mm		G3F - G3/8 female thread      G3M - G3/8 male thread
	50 - $\phi$ 50mm		

### Selection

Model	Connection thread		MPQ pcs
	M - Male thread	F - Female thread	
SBL15□	SBL15□-M5M	-	5
SBL20□	SBL20□-G1M	SBL20□-G1F	5
SBL30□	SBL30□-G1M	SBL30□-G1F	1
SBL40□	SBL40□-G1M	SBL40□-G1F	1
SBL50□	SBL50□-G2M      SBL50□-G3M	SBL50□-G2F      SBL50□-G3F	1

### Dimensions(mm) - Suction cup only

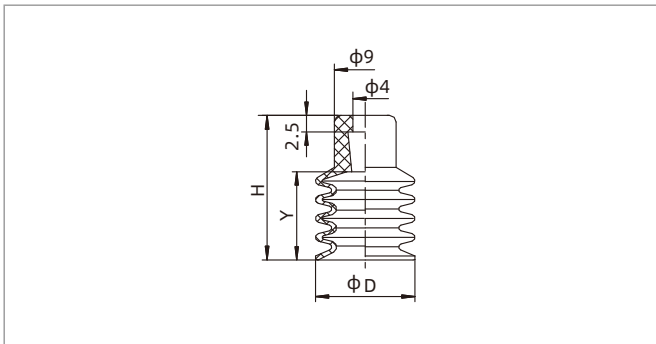

SBL15

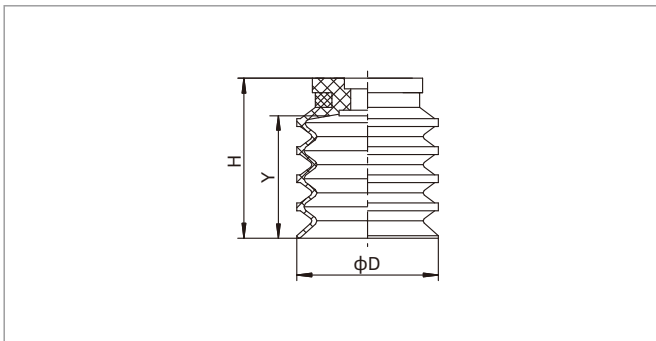

SBL20-50

Model/Size	D	H	Y	Weight g
SBL15□	15.5	21.5	13.5	12

Model/Size	D	H	Y	Weight g
SBL20□	20	23	17.5	2.3
SBL30□	30	32	25.5	5.8
SBL40□	40	42	34.5	12.4
SBL50□	50	52	40	20.9

- SZ
- SPH
- SP3
- SUF
- SAN
- SAO
- SOFA
- STP
- SFT
- SFA
- SBT
- SBL**
- SBLP
- SBS
- SFP
- SBP
- SXP
- SGP
- SBOF
- STC
- SFF
- SOB
- SOF
- SOG
- SFM
- SOM
- SBF
- SDM
- SFU
- SFK
- SHT
- SDL
- SFG
- SFGT
- SFD
- SB
- SBA
- SF
- SU
- SP2F
- SPA
- SPD
- SPF
- SPC
- SPJ
- SPU
- SH
- SHB
- SBB
- SOP
- SNP

# SBL Series

## 4.5 Bellows Suction Cup

### Dimensions(mm) - Suction cup with fitting

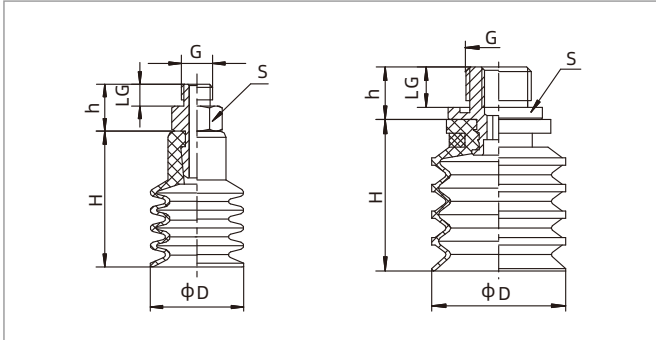

SBL - Male thread connection

Model/Size	D	H	h	G	LG	S
SBL15□-M5M	15.5	21.5	7.5	M5×0.8	3.5	7
SBL20□-G1M	20	23	7.8	G1/8	6	13
SBL30□-G1M	30	32	12	G1/8	6	17
SBL40□-G1M	40	42	12	G1/8	6	17
SBL50□-G2M	50	52	17	G1/4	9	24
SBL50□-G3M	50	52	18	G3/8	10	24

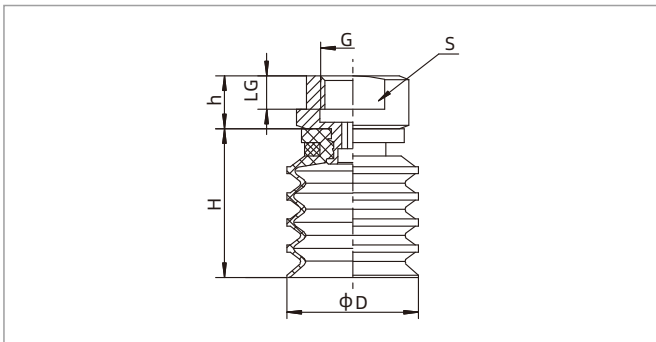

SBL - Female thread connection

Model/Size	D	H	h	G	LG	S
SBL20□-G1F	20	23	8	G1/8	7	13
SBL30□-G1F	30	32	10	G1/8	7	17
SBL40□-G1F	40	42	10	G1/8	7	17
SBL50□-G2F	50	52	13	G1/4	10	24
SBL50□-G3F	50	52	13	G3/8	11	24

◇ Note: The dimensional tolerance conforms to GBT3672.1-2002-1 M3 rubber product dimensional tolerance standard

### Mounting parts

Item	Model		Applicable suction cup
	M - Male thread	F - Female thread	
Fitting for suction cup	PJS-M5M-SC3	-	SBL15
	PJS-G1M-SF1	PJS-G1F-SF1	SBL20
	PJS-G1M-SF2	PJS-G1F-SF2	SBL30,40
	PJS-G2M-SF3	PJS-G2F-SF3	SBL50
	PJS-G3M-SF3	PJS-G3F-SF3	SBL50

# SBLP Series

## Bellows Suction Cup Special for Soft Packing Bags

**AIRBEST**



FOOD  
PACKAGING



PLASTIC BAG

RoHS

Suction Cup

### Features

- ◇ Thin sealing lip
- ◇ 4.5 Bellows structure
- ◇ Big size, increasing vacuum flow
- ◇ Food grade silicone
- ◇ Plugs are optional

### Advantages

- ◇ Have good airtightness when grab soft packing bag or flexible workpiece
- ◇ Effectively compensate height difference of packing bag with irregular shapes
- ◇ When grabbing porous workpieces, it can compensate the grabbing capacity by large flow
- ◇ Direct contact with food
- ◇ Prevent soft plastic film to be sucked into suction cup



### Applications

- ◇ Handling soft packing bag, such as EXPRESS bag, aluminum foil bags, laundry detergent bags, water bags, etc.
- ◇ Handling food package, such as bread, biscuits, milk, etc.
- ◇ Suitable for opening the bags, such as woven bags opening and dragging, etc.
- ◇ Grabbing packing bags containing solid products, powder or liquid safely

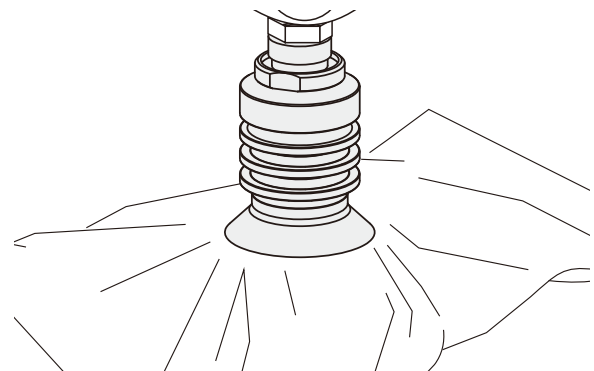

### Structure

- ◇ Multiple bellows, large compressed stroke
- ◇ Suction cup and fitting are split structure design, wearing parts can be replaced separately
- ◇ T1 - White round plug, for light, thin and soft workpieces with large deformation
- ◇ T2 - Blue flower shape plug, for hard workpieces with small deformation

T1 Round plug

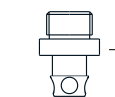

Fitting for suction cup

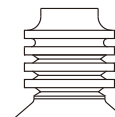

Replacement suction cup



T2 Flower shape plug

SZ  
SPH  
SP3  
SUF  
SAN  
SAO  
SOFA  
STP  
SFT  
SFA  
SBT  
**SBL**  
**SBLP**  
SBS  
SFP  
SBP  
SXP  
SGP  
SBOF  
STC  
SFF  
SOB  
SOF  
SOG  
SFM  
SOM  
SBF  
SDM  
SFU  
SFK  
SHT  
SDL  
SFG  
SFGT  
SFD  
SB  
SBA  
SF  
SU  
SP2F  
SPA  
SPD  
SPF  
SPC  
SPJ  
SPU  
SH  
SHB  
SBB  
SOP  
SNP

# SBLP Series

## Bellows Suction Cup Special for Soft Packing Bags

### How to order

## SBLP 40 S - G3M - T1

① ② ③ ④ ⑤

① Series	② Diameter	③ Material & Hardness	④ Connection thread	⑤ Special specification
SBLP	30 - $\phi$ 30mm 40 - $\phi$ 40mm 50 - $\phi$ 50mm	S - Silicone <b>40</b>	Nil - Suction cup G2M - G1/4 male thread G3M - G3/8 male thread G4M - G1/2 male thread	Nil - Standard T1 - White round plug T2 - Blue flower shape plug

### Selection

Model	M - Male thread	T1 - White round plug	T2 - Blue flower shape plug	MPQ pcs
SBLP30S	SBLP30S-G2M	-	SBLP30S-T2 SBLP30S-G2M-T2	1
SBLP40S	SBLP40S-G3M	SBLP40S-T1 SBLP40S-G3M-T1	SBLP40S-T2 SBLP40S-G3M-T2	1
SBLP50S	SBLP50S-G4M	-	SBLP50S-T2 SBLP50S-G4M-T2	1

### Dimensions(mm)

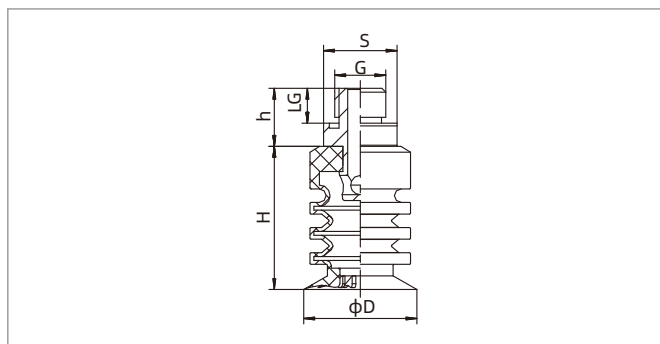

SBLP

Model/Size	D	H	G	h	LG	S	Weight g
SBLP30S-G2M	30	36.5	G1/4	15	9	19	14.4
SBLP40S-G3M	40	40	G3/8	16	10	22	24.1
SBLP50S-G4M	50	55	G1/2	16	10	28	43.3

◇ Note: The dimensional tolerance conforms to GB/T3672.1-2002-1 M3 rubber product dimensional tolerance standard

### Mounting parts

Item	Model M - Male thread	T1 - White round plug	T2 - Blue flower shape plug	Applicable suction cup
Fitting for suction cup	PJS-G2M-SBLP30	-	SBLP30-T2	SBLP30
	PJS-G3M-SBLP40	SBLP40-T1	SBLP40-T2	SBLP40
	PJS-G4M-SBLP50	-	SBLP50-T2	SBLP50

# SBS Series

## Bellows Suction Cup Special for Spherical Objects

**AIRBEST**



SPHERICAL OBJECT



FDA



Suction Cup

### Features

- ◇ Ultra-soft and tapered sealing lip
- ◇ Special inner structure
- ◇ Food grade silicone

### Advantages

- ◇ Effectively fit surface of spherical workpiece
- ◇ The corresponding suction cup can be accurately selected according to the shape of the adsorbed food
- ◇ Direct contact with food



### Applications

- ◇ Directly contact and handle candy and food, which are round, oval, and with irregular shapes
- ◇ Handling food with irregular surfaces or decorative shapes
- ◇ Multiple bellows suction cups are suitable for handling soft-contact food, such as eggs

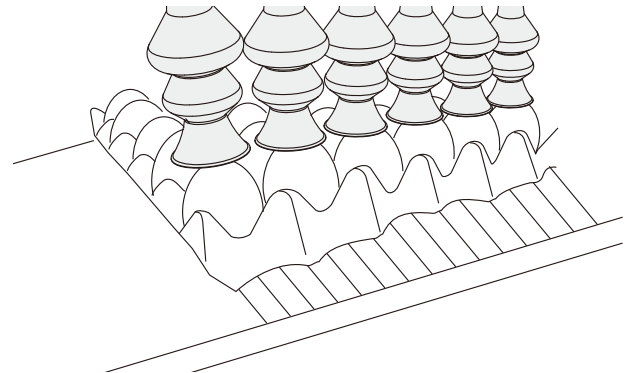

### Structure

- ◇ Special sealing lip, suitable for handling irregular products
- ◇ Ultra-thin, soft and tapered sealing lip, suitable for handling fragile objects

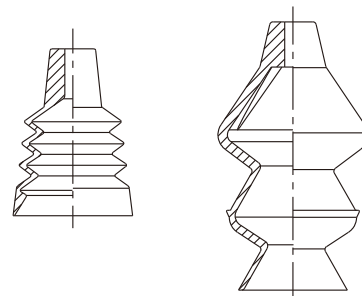

- SZ
- SPH
- SP3
- SUF
- SAN
- SAO
- SOFA
- STP
- SFT
- SFA
- SBT
- SBL
- SBLP
- SBS**
- SFP
- SBP
- SXP
- SGP
- SBOF
- STC
- SFF
- SOB
- SOF
- SOG
- SFM
- SOM
- SBF
- SDM
- SFU
- SFK
- SHT
- SDL
- SFG
- SFGT
- SFD
- SB
- SBA
- SF
- SU
- SP2F
- SPA
- SPD
- SPF
- SPC
- SPJ
- SPU
- SH
- SHB
- SBB
- SOP
- SNP

# SBS Series



## Bellows Suction Cup Special for Spherical Objects

### How to order

SBS 30 S

① ② ③

① Series	② Diameter	③ Material & Hardness
SBS	30 - $\phi$ 30mm	S - Silicone <span style="border: 1px solid black; padding: 0 2px;">35</span>
	33 - $\phi$ 33mm	WS - White silicone <span style="border: 1px solid black; padding: 0 2px;">50</span>
	34 - $\phi$ 34mm	WSA - White silicone <span style="border: 1px solid black; padding: 0 2px;">30</span>
	35 - $\phi$ 35mm	

### Selection

Model	Material S	WS	WSA	MPQ pcs	Weight g
SBS30	SBS30S	-	-	1	17
SBS33	-	SBS33WS	SBS33WSA	1	8
SBS34	SBS34S	SBS34WS	SBS34WSA	1	19.3
SBS35	-	SBS35WS	SBS35WSA	1	9.7

### Dimensions(mm)

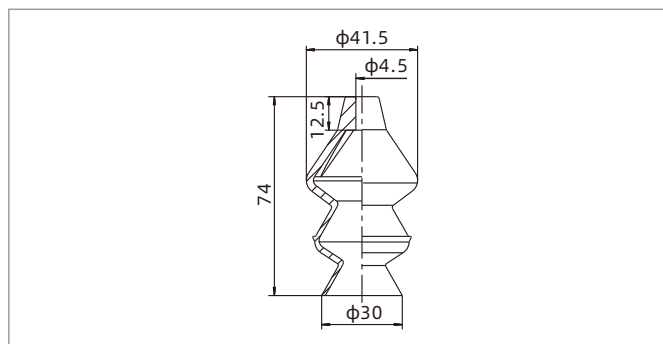

SBS30

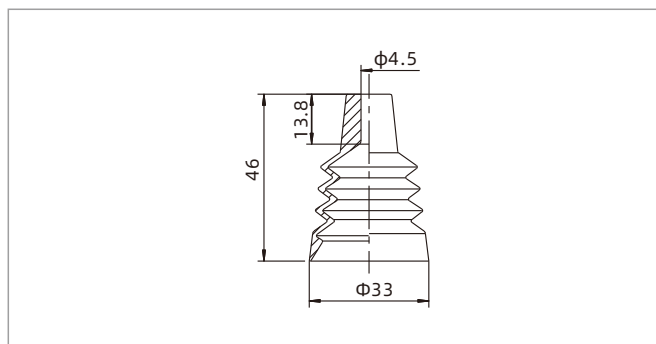

SBS33

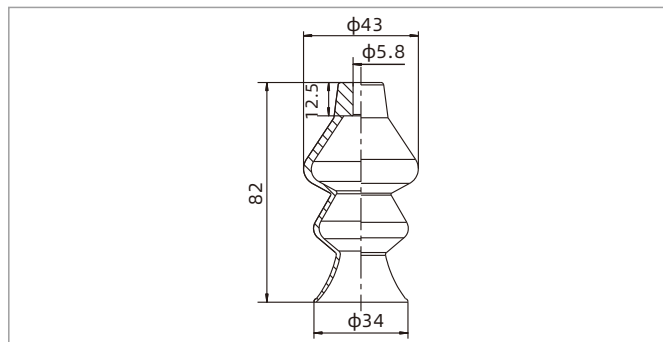

SBS34

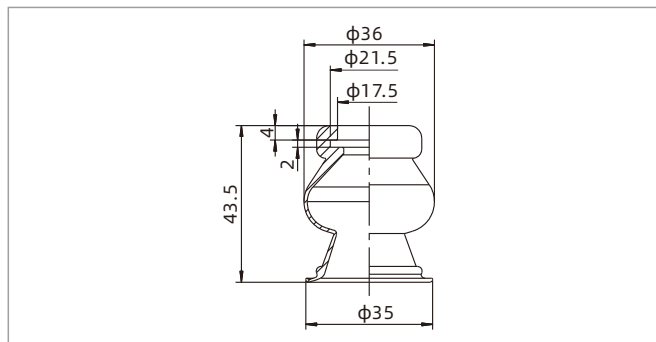

SBS35

◇ Note: The dimensional tolerance conforms to GB/T3672.1-2002-1 M3 rubber product dimensional tolerance standard

# SFP Series

## PU Flat Suction Cup



PACKAGING



LONG LIFETIME



### Features

- ◇ Support structure at bottom
- ◇ PU material
- ◇ Various sizes are available

### Advantages

- ◇ Preventing thin workpieces from permanent deformation
- ◇ Good wear resistance, long lifetime
- ◇ Suitable for workpieces with different sizes and shapes



### Applications

- ◇ Suitable for handling cardboard box or cardboard
- ◇ Suitable for handling carton or handling in packaging machinery
- ◇ Suitable for stacking and unstacking
- ◇ PU material has good wear resistance, suitable for heavy load occasions

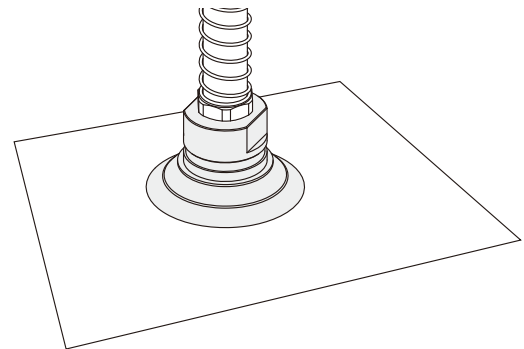

### Structure

- ◇ Suction cup and fitting are split structure design
- ◇ Fitting for suction cup is with mesh filter

In same series, replacement suction cup and fitting can be combined on request

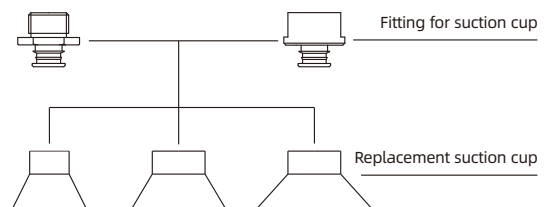

- SZ
- SPH
- SP3
- SUF
- SAN
- SAO
- SOFA
- STP
- SFT
- SFA
- SBT
- SBL
- SBLP
- SBS
- SFP**
- SBP
- SXP
- SGP
- SBOF
- STC
- SFF
- SOB
- SOF
- SOG
- SFM
- SOM
- SBF
- SDM
- SFU
- SFK
- SHT
- SDL
- SFG
- SFGT
- SFD
- SB
- SBA
- SF
- SU
- SP2F
- SPA
- SPD
- SPF
- SPC
- SPJ
- SPU
- SH
- SHB
- SBB
- SOP
- SNP

# SFP Series

## PU Flat Suction Cup

### How to order

SFP 20 U - G1F  
 ① ② ③ ④

① Series	② Diameter	③ Material & Hardness		④ Connection thread
SFP	20 - $\phi$ 20mm	U - PU	60	Nil - Suction cup only
	30 - $\phi$ 30mm	UY - PU	40	G1M - G1/8 male thread
	40 - $\phi$ 40mm			G1F - G1/8 female thread

### Selection

Model	Connection thread	
	M - Male thread	F - Female thread
SFP20□	SFP20□-G1M	SFP20□-G1F
SFP30□	SFP30□-G1M	SFP30□-G1F
SFP40□	SFP40□-G1M	SFP40□-G1F

### Technical parameters

Model	Pull-out force N	Inner volume cm <sup>3</sup>	Min.curve radius of workpiece mm	Weight g	Recommended hose dia. mm	MPQ pcs
SFP20	14	0.36	24	1.1	6	5
SFP30	21	1	42	2.5	6	5
SFP40	56.5	2.7	52	6	6	5

◇ Note: Testing vacuum level -60kPa, workpiece with smooth and clean surface. The data of pull-out force as above are figured out without considering safety factor. The data may be different according to different workpiece surfaces. Recommend the length of vacuum hose to be as short as possible, max 2m.

### Dimensions(mm) - Suction cup only

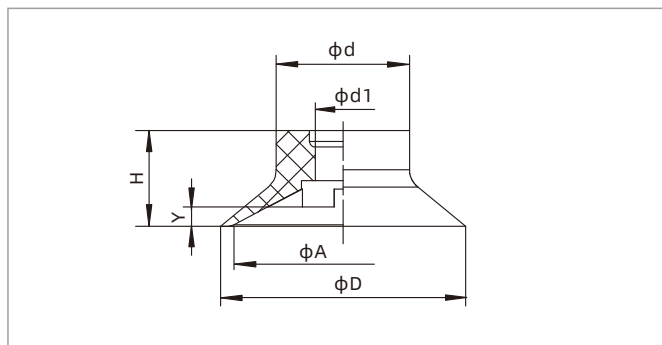

SFP20-40

Model/Size	D	H	A	d	d1	Y
SFP20□	22	8.6	20	12	5	1.6
SFP30□	31	10.5	30	15.8	5	2
SFP40□	41	14	40	21	6.5	2.5

# SFP Series

## PU Flat Suction Cup

### Dimensions(mm)

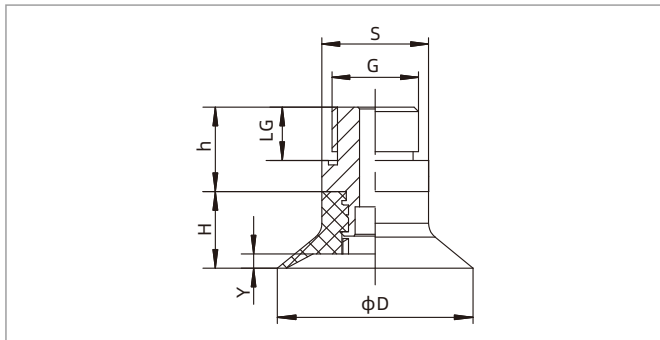

SFP20-40 Male thread connection

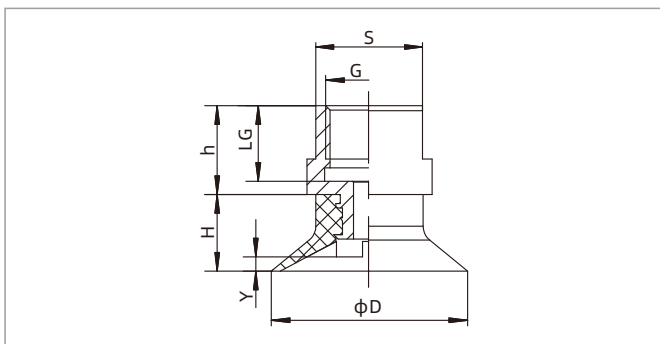

SFP20-40 Female thread connection

◇ Note: The dimensional tolerance conforms to GB/T3672.1-2002-1 M3 rubber product dimensional tolerance standard

Model/Size	D	H	G	h	LG	S	Y
SFP20□-G1M	22	8.6	G1/8	7.8	6	13	1.6
SFP30□-G1M	31	10.5	G1/8	7.8	6	13	2
SFP40□-G1M	41	14	G1/8	12	6	17	2.5

Model/Size	D	H	G	h	LG	S	Y
SFP20□-G1F	22	8.6	G1/8	8	7	13	1.6
SFP30□-G1F	31	10.5	G1/8	8	7	13	2
SFP40□-G1F	41	14	G1/8	10	7	17	2.5

### Mounting parts

Item	Model		Applicable suction cup
	M - Male thread	F - Female thread	
Fitting for suction cup	PJS-G1M-SF1-EW	PJS-G1F-SF1-EW	SFP20, 30
	PJS-G1M-SF2-EW	PJS-G1F-SF2-EW	SFP40

- SZ
- SPH
- SP3
- SUF
- SAN
- SAO
- SOFA
- STP
- SFT
- SFA
- SBT
- SBL
- SBLP
- SBS
- SFP**
- SBP
- SXP
- SGP
- SBOF
- STC
- SFF
- SOB
- SOE
- SOG
- SFM
- SOM
- SBF
- SDM
- SFU
- SFK
- SHT
- SDL
- SFG
- SFGT
- SFD
- SB
- SBA
- SF
- SU
- SP2F
- SPA
- SPD
- SPF
- SPC
- SPJ
- SPU
- SH
- SHB
- SBB
- SOP
- SNP

# SBP Series

## PU Bellows Suction Cup



PACKAGING



LONG LIFETIME



### Features

- ◇ 1.5 Bellows
- ◇ Internal support structure at bottom
- ◇ PU material
- ◇ Various sizes are available

### Advantages

- ◇ Easy to fit the uneven surface of workpiece, and has buffer effect
- ◇ Prevent thin workpieces from permanent deformation
- ◇ Good wear resistance, long lifetime
- ◇ Suitable for workpieces with different sizes and shapes



### Applications

- ◇ Suitable for handling cardboard box or cardboard
- ◇ Suitable for handling carton or handling in packaging machinery
- ◇ Suitable for stacking and unstacking
- ◇ PU material has good wear resistance, suitable for heavy load occasions

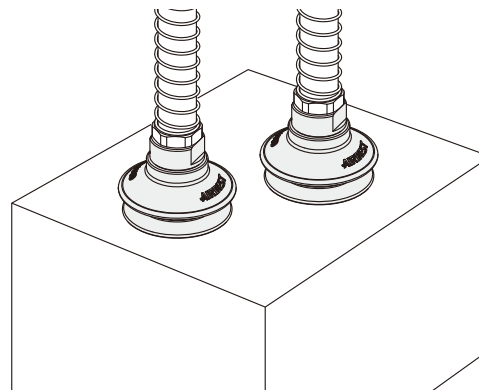

### Structure

- ◇ For suction cup with diameter  $\phi 10$ - $\phi 50$ mm, suction cup and fitting are split structure design
- ◇ For suction cup with diameter  $\phi 70$ mm, suction cup and fitting are one-piece structure design
- ◇ Fitting for suction cup is with filter mesh

In same series, replacement suction cup and fitting can be combined on request

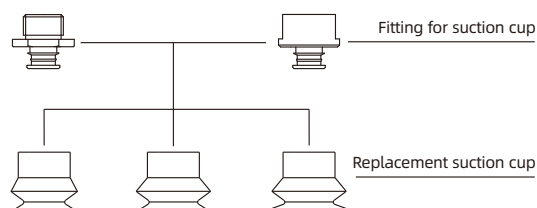

# SBP Series

## PU Bellows Suction Cup

### How to order

**SBP 30 U - G1F**  
 ①      ②      ③      ④

① Series	② Diameter	③ Material & Hardness	④ Connection thread
SBP	10 - φ10mm	U - PU <span style="background-color: #0056b3; color: white; padding: 2px;">60</span>	Nil - Suction cup only
	15 - φ15mm	UY - PU <span style="background-color: #ffcc00; padding: 2px;">40</span>	M5M - M5x0.8 male thread
	20 - φ20mm	UD - PU <span style="background-color: #0056b3; color: white; padding: 2px;">30 60</span>	G1M - G1/8 male thread
	30 - φ30mm		G2M - G1/4 male thread
	40 - φ40mm		G3M - G3/8 male thread
	50 - φ50mm		G1F - G1/8 female thread
	70 - φ70mm		G2F - G1/4 female thread G3F - G3/8 female thread

### Selection

Model	Connection thread	
	M - Male thread	F - Female thread
SBP10□	SBP10□-M5M	-
SBP15□	SBP15□-M5M	-
SBP20□	SBP20□-G1M	SBP20□-G1F
SBP30□	SBP30□-G1M	SBP30□-G1F
SBP40□	SBP40□-G1M	SBP40□-G1F
SBP50□	SBP50□-G2M    SBP50□-G3M	SBP50□-G2F    SBP50□-G3F
SBP70□	SBP70□-G3M	SBP70□-G3F

◇ Note: UD material is not available for SBP10

### Technical parameters

Model	Pull-out force N	Inner volume cm <sup>3</sup>	Min.curve radius of workpiece mm	Weight g	Recommended hose dia. mm	MPQ pcs
SBP10	3.5	0.2	10	0.8	6	5
SBP15	7.9	0.5	25	1.4	6	5
SBP20	14	2	31	2.1	6	5
SBP30	31	4	47	4.8	6	5
SBP40	56.5	9	59	11.5	6	1
SBP50	88	17	68	20.7	8	1
SBP70	173	55	91	68.3	10	1

◇ Note: Testing vacuum level -60kPa, workpiece with smooth and clean surface. The data of pull-out force as above are figured out without considering safety factor. The data may be different according to different workpiece surfaces. Recommend the length of vacuum hose to be as short as possible, max 2m.

- SZ
- SPH
- SP3
- SUF
- SAN
- SAO
- SOFA
- STP
- SFT
- SFA
- SBT
- SBL
- SBLP
- SBS
- SFP
- SBP**
- SXP
- SGP
- SBOF
- STC
- SFF
- SOB
- SOF
- SOG
- SFM
- SOM
- SBF
- SDM
- SFU
- SFK
- SHT
- SDL
- SFG
- SFGT
- SFD
- SB
- SBA
- SF
- SU
- SP2F
- SPA
- SPD
- SPF
- SPC
- SPJ
- SPU
- SH
- SHB
- SBB
- SOP
- SNP

# SBP Series

## PU Bellows Suction Cup

### Dimensions(mm)

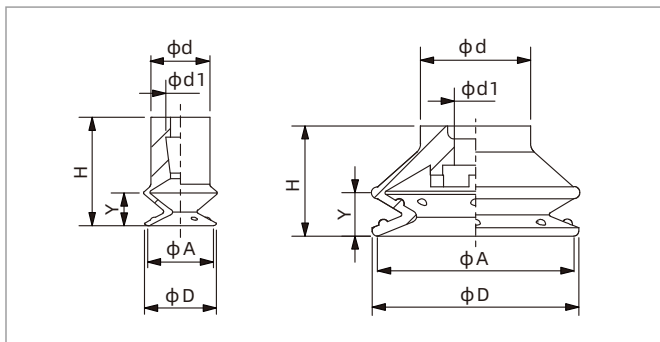

SBP10-15

SBP20-50

Model/Size	D	H	A	d	d1	Y
SBP10□	10.9	16.5	10	9	5	5
SBP15□	16	19	15	9	5.5	5.8
SBP20□	21	18	20	12	5	7.5
SBP30□	31.5	16.8	30	16.8	6.5	6.6
SBP40□	42	22.4	40	22.4	6.5	8.8
SBP50□	52.5	29.3	50	28	10.5	12.3

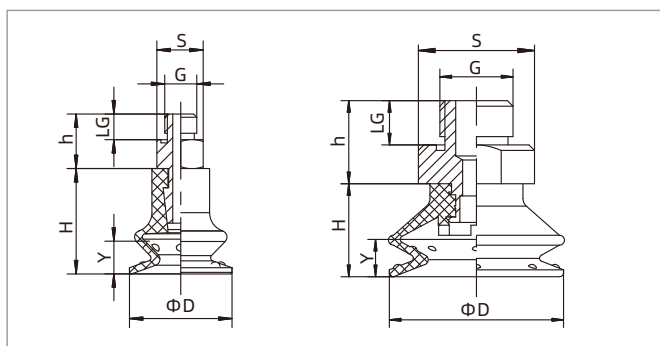

SBP10-50 Male thread connection

Model/Size	D	H	G	h	LG	S	Y
SBP10□-M5M	10.9	16.5	M5×0.8	7.5	3.5	7	5
SBP15□-M5M	16	19	M5×0.8	7.5	3.5	7	5.8
SBP20□-G1M	21	18	G1/8	7.8	6	13	7.5
SBP30□-G1M	31.5	16.8	G1/8	12	6	17	6.6
SBP40□-G1M	42	22.4	G1/8	12	6	17	8.8
SBP50□-G2M	52.5	29.3	G1/4	17	9	24	12.3
SBP50□-G3M	52.5	29.3	G3/8	18	10	24	12.3

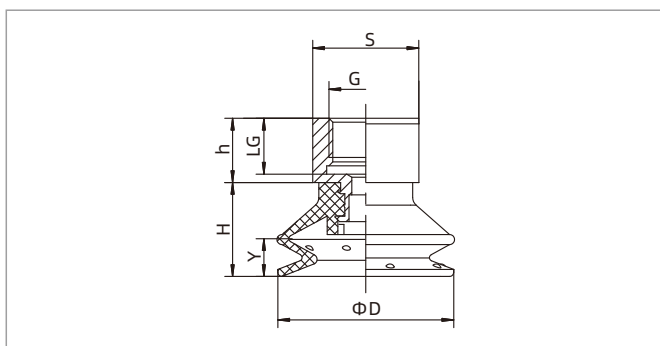

SBP20-50 Female thread connection

Model/Size	D	H	G	h	LG	S	Y
SBP20□-G1F	21	18	G1/8	8	7	13	7.5
SBP30□-G1F	31.5	16.8	G1/8	10	7	17	6.6
SBP40□-G1F	42	22.4	G1/8	10	7	17	8.8
SBP50□-G2F	52.5	29.3	G1/4	13	10	24	12.3
SBP50□-G3F	52.5	29.3	G3/8	13	11	24	12.3

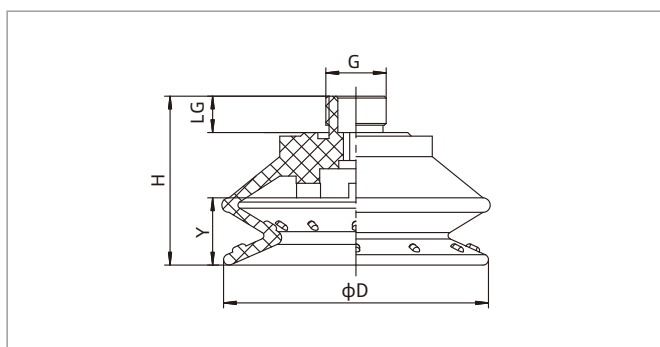

SBP70 Male thread connection

Model/Size	D	H	G	LG	Y
SBP70□-G3M	73	46.5	G3/8	10	16.5

# SBP Series

## PU Bellows Suction Cup

### Dimensions(mm)

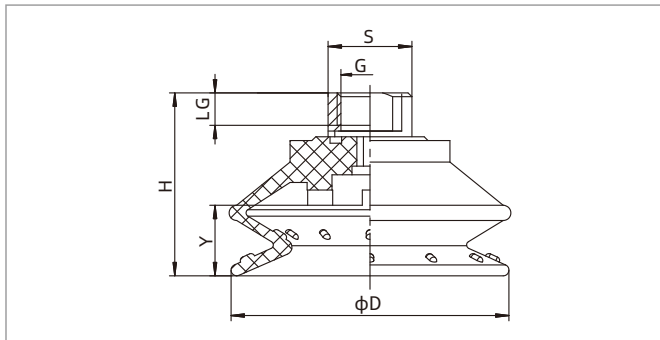

Model/Size	D	H	G	LG	S	Y
SBP70□-G3F	73	48	G3/8	11.5	22	16.5

SBP70 Female thread connection

◇ Note: The dimensional tolerance conforms to GB/T3672.1-2002-1 M3 rubber product dimensional tolerance standard

### Mounting parts

Item	Model M - Male thread	F - Female thread	Applicable suction cup
Fitting for suction cup	PJS-M5M-SC3	-	SBP10, 15
	PJS-G1M-SF1-EW	PJS-G1F-SF1-EW	SBP20
	PJS-G1M-SF2-EW	PJS-G1F-SF2-EW	SBP30, 40
	PJS-G2M-SF3-EW	PJS-G2F-SF3-EW	SBP50
	PJS-G3M-SF3-EW	PJS-G3F-SF3-EW	SBP50

- SZ
- SPH
- SP3
- SUF
- SAN
- SAO
- SOFA
- STP
- SFT
- SFA
- SBT
- SBL
- SBLP
- SBS
- SFP
- SBP**
- SXP
- SGP
- SBOF
- STC
- SFF
- SOB
- SOE
- SOG
- SFM
- SOM
- SBF
- SDM
- SFU
- SFK
- SHT
- SDL
- SFG
- SFGT
- SFD
- SB
- SBA
- SF
- SU
- SP2F
- SPA
- SPD
- SPF
- SPC
- SPJ
- SPU
- SH
- SHB
- SBB
- SOP
- SNP

# SXP Series

## PU Bellows Suction Cup

**AIRBEST**



PACKAGING



LONG LIFETIME



### Features

- ◇ 2.5 Bellows
- ◇ Internal support structure at bottom
- ◇ PU material
- ◇ Various sizes are available

### Advantages

- ◇ Easy to fit uneven surface of workpiece, and has buffer effect
- ◇ Prevent thin workpieces from permanent deformation
- ◇ Good wear resistance, long lifetime
- ◇ Suitable for workpieces with different sizes and shapes



### Applications

- ◇ Suitable for workpieces with every uneven surfaces, such as cartons, pipes, etc, fitting surfaces perfectly
- ◇ Suitable for handling cardboard box or cardboard
- ◇ Suitable for handling carton or handling in packaging machinery
- ◇ PU material has good wear resistance, suitable for heavy load occasions

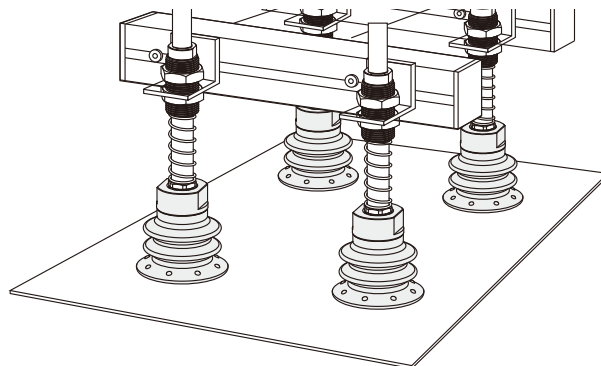

### Structure

- ◇ For suction cup with diameter  $\phi 20$ - $\phi 50$ mm, suction cup and fitting are split structure design
- ◇ For suction cup with diameter  $\phi 70$ mm, suction cup and fitting are one-piece structure design
- ◇ Fitting for suction cup is with filter mesh

In same series, replacement suction cup and fitting can be combined on request

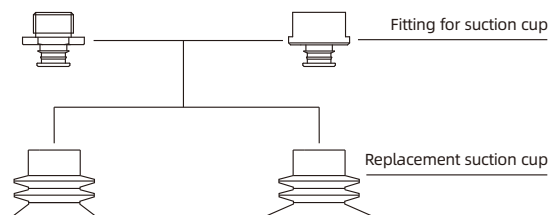

# SXP Series

## PU Bellows Suction Cup

### How to order

**SXP 30 U - G1F**  
 ①      ②      ③      ④

① Series	② Diameter	③ Material & Hardness	④ Connection thread
SXP	20 - φ20mm	U - PU <span style="background-color: #000080; color: white; padding: 2px;">60</span>	Nil - Suction cup only
	25 - φ25mm	UG - PU <span style="background-color: #008000; color: white; padding: 2px;">55</span>	G1M - G1/8 male thread
	30 - φ30mm	UD - PU <span style="background-color: #000080; color: white; padding: 2px;">30 60</span>	G2M - G1/4 male thread
	35 - φ35mm		G3M - G3/8 male thread
	40 - φ40mm		G1F - G1/8 female thread
	50 - φ50mm		G2F - G1/4 female thread
	70 - φ70mm		G3F - G3/8 female thread

### Selection

Model	Connection thread	
	M - Male thread	F - Female thread
SXP20□	SXP20□-G1M	SXP20□-G1F
SXP25□	SXP25□-G1M	SXP25□-G1F
SXP30□	SXP30□-G1M	SXP30□-G1F
SXP35□	SXP35□-G1M	SXP35□-G1F
SXP40□	SXP40□-G1M	SXP40□-G1F
SXP50□	SXP50□-G2M    SXP50□-G3M	SXP50□-G2F    SXP50□-G3F
SXP70□	SXP70□-G3M	SXP70□-G3F

### Technical parameters

Model	Pull-out force N	Inner volume cm <sup>3</sup>	Min.curve radius of workpiece mm	Weight g	Recommended hose dia. mm	MPQ pcs
SXP20	14	2	24	1.8	6	5
SXP25	22	3	31	3.1	6	5
SXP30	31	5	30	4.4	6	5
SXP35	43	9	39	7.4	6	1
SXP40	56.5	11	45	10.4	6	1
SXP50	88	21	55	19.9	8	1
SXP70	173	55	80	66	10	1

◇ Note: Testing vacuum level -60kPa, workpiece with smooth and clean surface. The data of pull-out force as above are figured out without considering safety factor. The data may be different according to different workpiece surfaces. Recommend the length of vacuum hose to be as short as possible, max 2m.

- SZ
- SPH
- SP3
- SUF
- SAN
- SAO
- SOFA
- STP
- SFT
- SFA
- SBT
- SBL
- SBLP
- SBS
- SFP
- SBP
- SXP**
- SGP
- SBOF
- STC
- SFF
- SOB
- SOE
- SOG
- SFM
- SOM
- SBF
- SDM
- SFU
- SFK
- SHT
- SDL
- SFG
- SFGT
- SFD
- SB
- SBA
- SF
- SU
- SP2F
- SPA
- SPD
- SFP
- SPC
- SPJ
- SPU
- SH
- SHB
- SBB
- SOP
- SNP

# SXP Series

## PU Bellows Suction Cup

### Dimensions(mm)

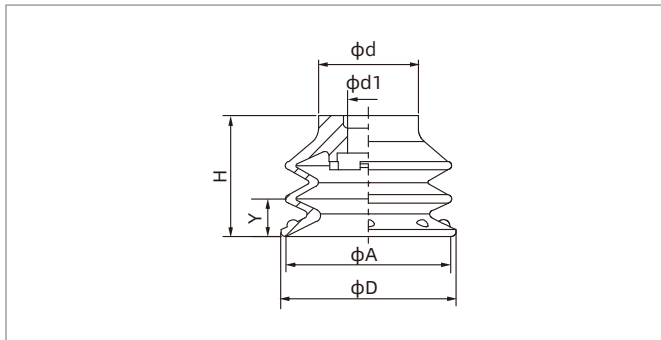

SXP20-50

Model/Size	D	H	A	d	d1	Y
SXP20□	21	14.8	20	12	5	4.5
SXP25□	26	18.9	24.4	15.4	5	7.3
SXP30□	30	21.3	28	16.5	5	8
SXP35□	35	25.3	33	21	6.5	9.8
SXP40□	40	28.4	37.5	22	6.5	10.6
SXP50□	50	35.5	47	27.5	10.5	13.4

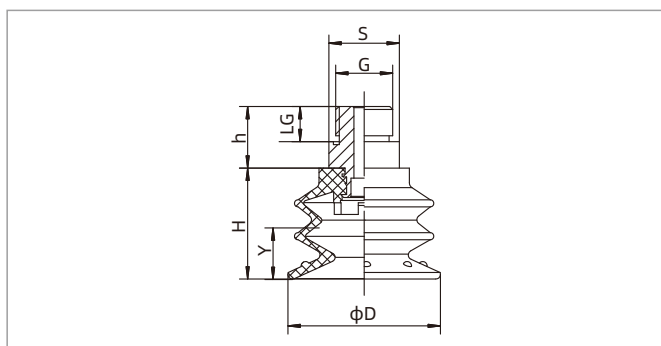

SXP20-50 Male thread connection

Model/Size	D	H	G	h	LG	S	Y
SXP20□-G1M	21	14.8	G1/8	7.8	6	13	4.5
SXP25□-G1M	26	18.9	G1/8	7.8	6	13	7.3
SXP30□-G1M	30	21.3	G1/8	7.8	6	13	8
SXP35□-G1M	35	25.3	G1/8	12	6	17	9.8
SXP40□-G1M	40	28.4	G1/8	12	6	17	10.6
SXP50□-G2M	50	35.5	G1/4	17	9	24	13.4
SXP50□-G3M	50	35.5	G3/8	18	10	24	13.4

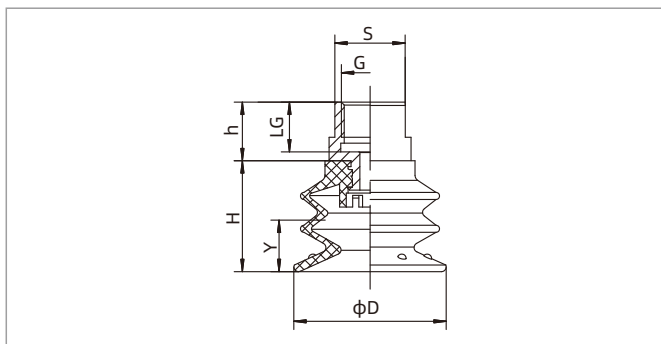

SXP20-50 Female thread connection

Model/Size	D	H	G	h	LG	S	Y
SXP20□-G1F	21	14.8	G1/8	8	7	13	4.5
SXP25□-G1F	26	18.9	G1/8	8	7	13	7.3
SXP30□-G1F	30	21.3	G1/8	8	7	13	8
SXP35□-G1F	35	25.3	G1/8	10	7	17	9.8
SXP40□-G1F	40	28.4	G1/8	10	7	17	10.6
SXP50□-G2F	50	35.5	G1/4	13	10	24	13.4
SXP50□-G3F	50	35.5	G3/8	13	11	24	13.4

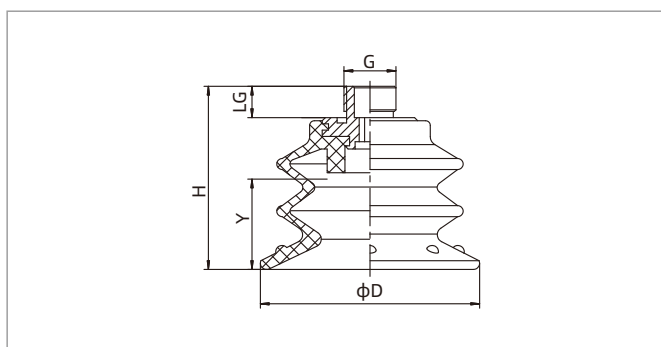

SXP70 Male thread connection

Model/Size	D	H	G	LG	Y
SXP70□-G3M	70	58.5	G3/8	10	18.6

# SXP Series

## PU Bellows Suction Cup

### Dimensions(mm)

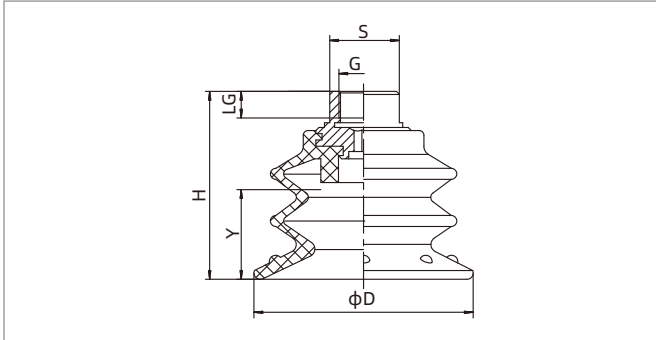

Model/Size	D	H	G	LG	S	Y
SXP70□-G3F	70	60	G3/8	11.5	22	18.6

SXP70 Female thread connection

◇ Note: The dimensional tolerance conforms to GBT3672.1-2002-1 M3 rubber product dimensional tolerance standard

### Mounting parts

Item	Model M - Male thread	F - Female thread	Applicable suction cup
Fitting for suction cup	PJS-G1M-SF1-EW	PJS-G1F-SF1-EW	SXP20, 25, 30
	PJS-G1M-SF2-EW	PJS-G1F-SF2-EW	SXP35, 40
	PJS-G2M-SF3-EW	PJS-G2F-SF3-EW	SXP50
	PJS-G3M-SF3-EW	PJS-G3F-SF3-EW	SXP50

- SZ
- SPH
- SP3
- SUF
- SAN
- SAO
- SOFA
- STP
- SFT
- SFA
- SBT
- SBL
- SBLP
- SBS
- SFP
- SBP
- SXP**
- SGP
- SBOF
- STC
- SFF
- SOB
- SOE
- SOG
- SFM
- SOM
- SBF
- SDM
- SFU
- SFK
- SHT
- SDL
- SFG
- SFGT
- SFD
- SB
- SBA
- SF
- SU
- SP2F
- SPA
- SPD
- SPF
- SPC
- SPJ
- SPU
- SH
- SHB
- SBB
- SOP
- SNP

# SGP Series

## PU Bellows Suction Cup

**AIRBEST**



PACKAGING



LONG  
LIFETIME



### Features

- ◇ 2.5 Bellows
- ◇ Internal support structure at bottom
- ◇ PU material
- ◇ Various sizes are available

### Advantages

- ◇ Easy to fit uneven surface of workpiece, and has buffer effect
- ◇ Prevent thin workpieces from permanent deformation
- ◇ Good wear resistance, long lifetime
- ◇ Suitable for workpieces with different sizes and shapes



### Applications

- ◇ Suitable for workpieces with every uneven surfaces, such as cartons, pipes, etc, fit surfaces perfectly
- ◇ Suitable for handling cardboard box or cardboard
- ◇ Suitable for handling carton or handling in packaging machinery
- ◇ PU material has good wear resistance, suitable for heavy load occasions

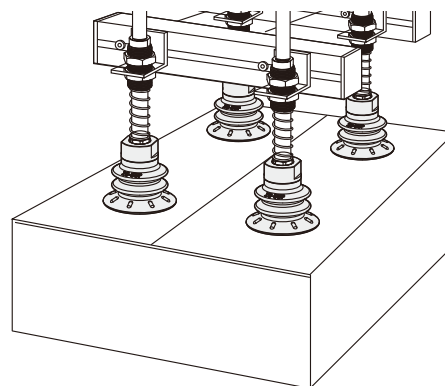

### Structure

- ◇ Suction cup and fitting are split structure design
- ◇ Fitting for suction cup is with filter mesh

In same series, replacement suction cup and fitting can be combined on request

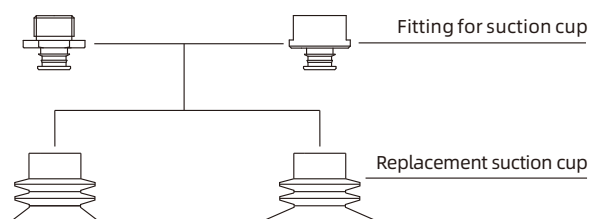

# SGP Series

## PU Bellows Suction Cup

### How to order

SGP 35 U - G1F  
 ①      ②      ③      ④

① Series	② Diameter	③ Material & Hardness	④ Connection thread
SGP	25 - $\phi$ 25mm	U - PU <span style="background-color: #008000; color: white; padding: 2px;">55</span>	Nil - Suction cup only
	35 - $\phi$ 35mm	UD - PU <span style="background-color: #0000FF; color: white; padding: 2px;">30</span>	G1M - G1/8 male thread
	45 - $\phi$ 45mm		G2M - G1/4 male thread
	55 - $\phi$ 55mm		G3M - G3/8 male thread
			G1F - G1/8 female thread
			G2F - G1/4 female thread
			G3F - G3/8 female thread

### Selection

Model	Connection thread	
	M - Male thread	F - Female thread
SGP25□	SGP25□-G1M	SGP25□-G1F
SGP35□	SGP35□-G1M	SGP35□-G1F
SGP45□	SGP45□-G1M	SGP45□-G1F
SGP55□	SGP55□-G2M    SGP55□-G3M	SGP55□-G2F    SGP55□-G3F

### Technical parameters

Model	Pull-out force N	Inner volume cm <sup>3</sup>	Min.curve radius of workpiece mm	Weight g	Recommended hose dia. mm	MPQ pcs
SGP25	22	3	31	2	6	5
SGP35	43	6	42	4.8	6	5
SGP45	71	13	54	11	6	1
SGP55	106	23	64	19.9	8	1

◇ Note: Testing vacuum level -60kPa, workpiece with smooth and clean surface. The data of pull-out force as above are figured out without considering safety factor. The data may be different according to different workpiece surfaces. Recommend the length of vacuum hose to be as short as possible, max 2m.

### Dimensions(mm)

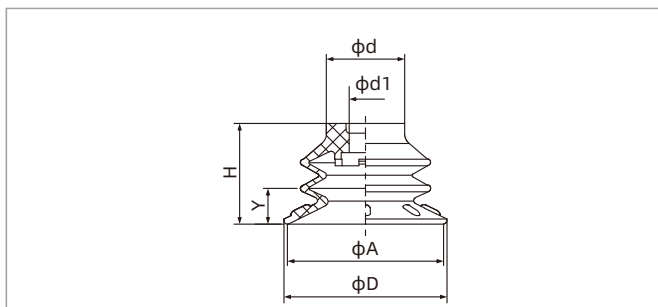

Model/Size	D	H	A	d	d1	γ
SGP25□	25	15.5	24	12	5	5.5
SGP35□	35	22.3	33.4	16.5	5	8.4
SGP45□	45	29.3	42.8	22	6.6	11.5
SGP55□	55	36.3	52.4	27.5	10.5	12.9

SGP25-55

- SZ
- SPH
- SP3
- SUF
- SAN
- SAO
- SOFA
- STP
- SFT
- SFA
- SBT
- SBL
- SBLP
- SBS
- SFP
- SBP
- SXP
- SGP
- SBOF
- STC
- SFF
- SOB
- SOE
- SOG
- SFM
- SOM
- SBF
- SDM
- SFU
- SFK
- SHT
- SDL
- SFG
- SFGT
- SFD
- SB
- SBA
- SF
- SU
- SP2F
- SPA
- SPD
- SPF
- SPC
- SPJ
- SPU
- SH
- SHB
- SBB
- SOP
- SNP

# SGP Series

## PU Bellows Suction Cup

### Dimensions(mm)

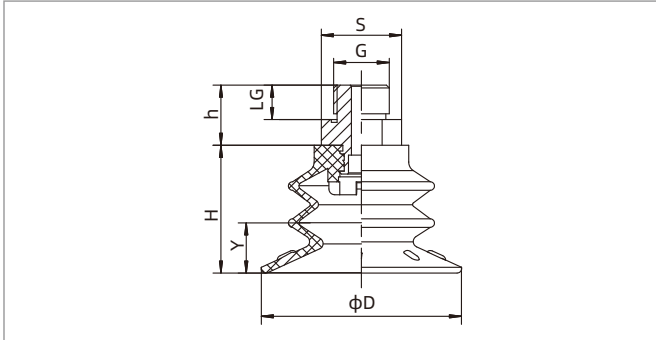

SGP25-55 Male thread connection

Model/Size	D	H	G	h	LG	S	Y
SGP25□-G1M	25	15.5	G1/8	7.8	6	13	5.5
SGP35□-G1M	35	22.3	G1/8	7.8	6	13	8.4
SGP45□-G1M	45	29.3	G1/8	12	6	17	11.5
SGP55□-G2M	55	36.3	G1/4	17	9	24	12.9
SGP55□-G3M	55	36.3	G3/8	18	10	24	12.9

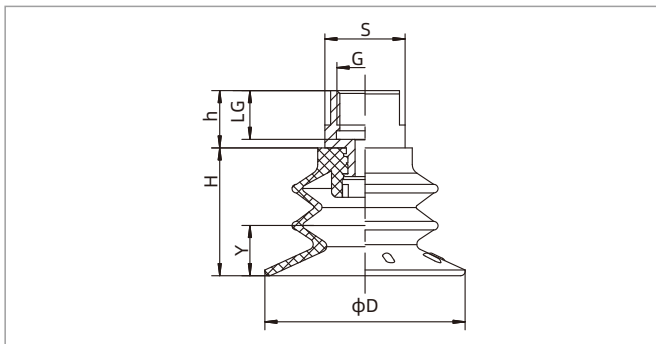

SGP25-55 Female thread connection

Model/Size	D	H	G	h	LG	S	Y
SGP25□-G1F	25	15.5	G1/8	8	7	13	5.5
SGP35□-G1F	35	22.3	G1/8	8	7	13	8.4
SGP45□-G1F	45	29.3	G1/8	10	7	17	11.5
SGP55□-G2F	55	36.3	G1/4	13	10	24	12.9
SGP55□-G3F	55	36.3	G3/8	13	11	24	12.9

◇ Note: The dimensional tolerance conforms to GBT3672.1-2002-1 M3 rubber product dimensional tolerance standard

### Mounting parts

Item	Model M - Male thread	F - Female thread	Applicable suction cup
Fitting for suction cup	PJS-G1M-SF1-EW	PJS-G1F-SF1-EW	SGP25, 35
	PJS-G1M-SF2-EW	PJS-G1F-SF2-EW	SGP45
	PJS-G2M-SF3-EW	PJS-G2F-SF3-EW	SGP55
	PJS-G3M-SF3-EW	PJS-G3F-SF3-EW	SGP55

# SBOF Series

## 2.5 Bellows Oval Suction Cup



PACKAGING PHARMACEUTICALS LONG LIFETIME



### Features

- ◇ 2.5 Bellows oval suction cup
- ◇ Material Vinyl

### Advantages

- ◇ Easy to fit uneven surface of workpiece, and has buffer effect
- ◇ Excellent wearing resistance, long lifetime



### Applications

- ◇ Suitable for unpacking machines and handling soft packaging products
- ◇ Suitable for medical industry, such as washing packing bags containing chlorinated disinfectant
- ◇ Suitable for handling CD and DVD

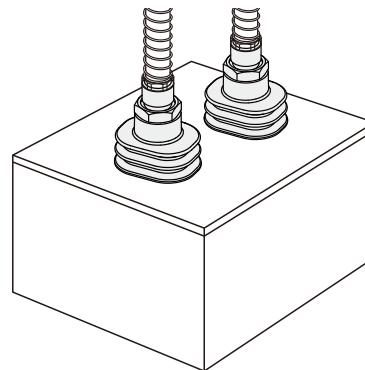

### Structure

- ◇ 2.5 Bellows, large compressed stroke
- ◇ Suction cup and fitting are split structure design, wearing parts can be replaced separately

In same series, replacement suction cup and fitting can be combined on request.

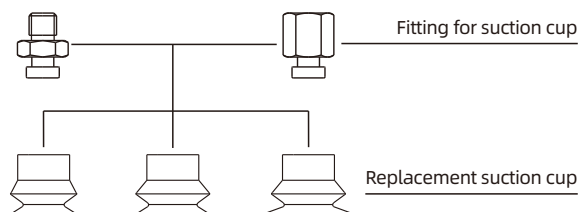

- SZ
- SPH
- SP3
- SUF
- SAN
- SAO
- SOFA
- STP
- SFT
- SFA
- SBT
- SBL
- SBLP
- SBS
- SFP
- SBP
- SXP
- SGP
- SBOF**
- STC
- SFF
- SOB
- SOF
- SOG
- SFM
- SOM
- SBF
- SDM
- SFU
- SFK
- SHT
- SDL
- SFG
- SFGT
- SFD
- SB
- SBA
- SF
- SU
- SP2F
- SPA
- SPD
- SPF
- SPC
- SPJ
- SPU
- SH
- SHB
- SBB
- SOP
- SNP

# SBOF Series

## 2.5 Bellows Oval Suction Cup

### How to order

## SBOF 35×28 V - G2M

①                      ②                      ③                      ④

① Series	② Size	③ Material & Hardness	④ Connection thread
SBOF	35×28 mm 45×28 mm	V - Vinyl <span style="background-color: #0070C0; color: white; padding: 2px;">55</span>	Nil - Suction cup only M10M - M10×1.5 male thread G2M - G1/4 male thread G2F - G1/4 female thread

### Selection

Model	Connection thread	
	M - Male thread	F - Female thread
SBOF35×28V	SBOF35×28V-M10M    SBOF35×28V-G2M	SBOF35×28V-G2F
SBOF45×28V	SBOF45×28V-M10M    SBOF45×28V-G2M	SBOF45×28V-G2F

### Technical parameters

Model	Pull-out force N	Inner volume cm <sup>3</sup>	Min.curve radius of workpiece mm	Weight g	Recommended hose dia. mm	MPQ pcs
SBOF35×28	44	22	39	5.8	8	1
SBOF45×28	57	26	39	8.2	8	1

◇ Note: Testing vacuum level -60kPa, workpiece with smooth and clean surface. The data of pull-out force as above are figured out without considering safety factor. The data may be different according to different workpiece surfaces. Recommend the length of vacuum hose to be as short as possible, max 2m.

### Dimensions(mm) - Suction cup only

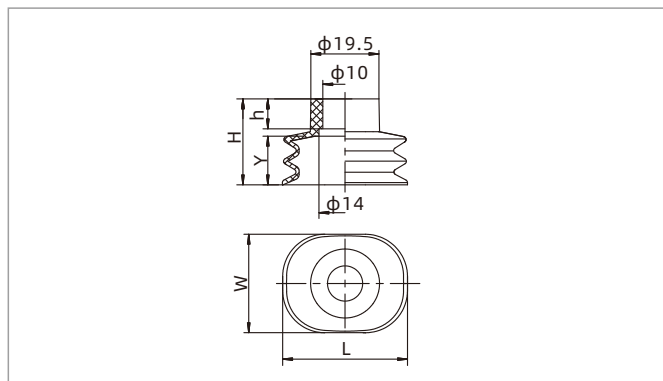

Model/Size	L	W	H	h	Y(Stroke)
SBOF35×28V	35	28	24.5	8.5	12
SBOF45×28V	45	28	25	9.5	13

SBOF

# SBOF Series

## 2.5 Bellows Oval Suction Cup

### Dimensions(mm) - Suction cup with fitting

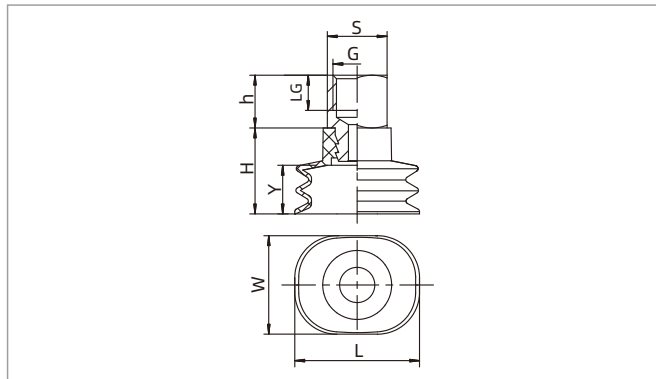
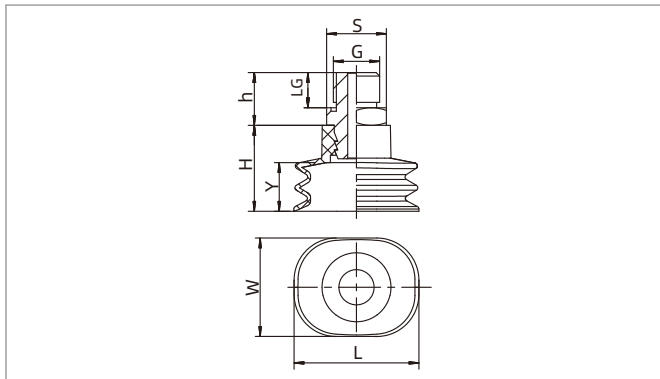

SBOF - Male thread connection

SBOF - Female thread connection

Model/Size	L	W	H	h	G	LG	S	Y
SBOF35×28V-M10M	35	28	24.5	15	M10×1.5	10	17	12
SBOF35×28V-G2M	35	28	24.5	15	G1/4	10	17	12
SBOF35×28V-G2F	35	28	24.5	15	G1/4	12	17	12
SBOF45×28V-M10M	45	28	25	15	M10×1.5	10	17	13
SBOF45×28V-G2M	45	28	25	15	G1/4	10	17	13
SBOF45×28V-G2F	45	28	25	15	G1/4	12	17	13

◇ Note: The dimensional tolerance conforms to GBT3672.1-2002-1 M3 rubber product dimensional tolerance standard

### Mounting parts

Item	Model	Applicable suction cup
Fitting for suction cup	PJS-M10M-SBOF	SBOF35×28,SBOF45×28
	PJS-G2M-SBOF	SBOF35×28,SBOF45×28
	PJS-G2F-SBOF	SBOF35×28,SBOF45×28

- SZ
- SPH
- SP3
- SUF
- SAN
- SAO
- SOFA
- STP
- SFT
- SFA
- SBT
- SBL
- SBLP
- SBS
- SFP
- SBP
- SXP
- SGP
- SBOF**
- STC
- SFF
- SOB
- SOF
- SOG
- SFM
- SOM
- SBF
- SDM
- SFU
- SFK
- SHT
- SDL
- SFG
- SFGT
- SFD
- SB
- SBA
- SF
- SU
- SP2F
- SPA
- SPD
- SPF
- SPC
- SPJ
- SPU
- SH
- SHB
- SBB
- SOP
- SNP

# STC Series

**AIRBEST**

## 1.5 Bellows Suction Cup Special for Metal Sheet



METAL SHEET



SLIPPING RESISTANCE



OILY SURFACE



### Features

- ◇ 1.5 Bellows structure
- ◇ Internal large area pattern support structure
- ◇ Various sizes and specifications are available

### Advantages

- ◇ Easy to fit the uneven surface of workpiece, and has buffer effect
- ◇ Effectively enhance friction force between suction cups and workpieces
- ◇ The max. temp of HK material is 250°C, it can be used to pick up high temp metal sheet
- ◇ The max. temp of HD material is 160°C, it can be used to pick up high temp glass without mark
- ◇ Suitable for workpieces with different sizes and shapes



### Applications

- ◇ Suitable for fast handling of metal plates, short cycle time
- ◇ Handling metal sheet and aluminum plates without deformation
- ◇ The internal special pattern groove design prevents the oily sheet metal from slipping during handling
- ◇ Used in automotive stamping metal parts handling system

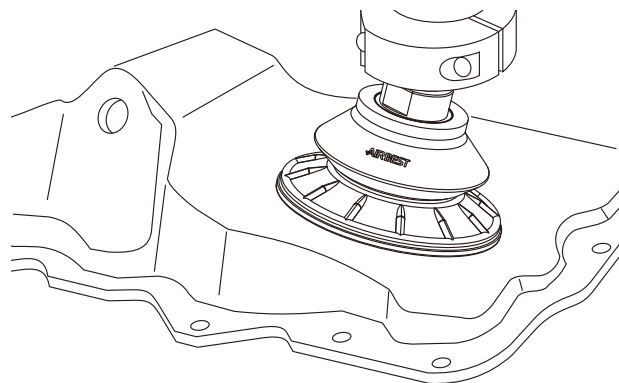

### Structure

- ◇ 1.5 Bellows structure, large compressed stroke
- ◇ Suction cup and fitting are one-piece structure design

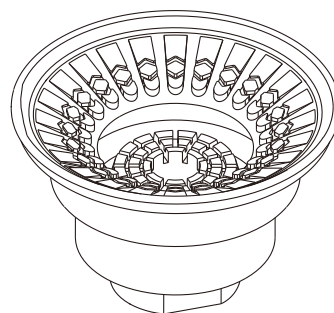

# STC Series

## 1.5 Bellows Suction Cup Special for Metal Sheet

### How to order

## STC 50 N - G3F

①      ②      ③      ④

① Series	② Diameter	③ Material & Hardness	④ Connection thread
STC	22 - φ22mm	N - NBR	60 G2F - G1/4 female thread
	30 - φ30mm	HK - Extra high temp rubber	65 G3F - G3/8 female thread
	40 - φ40mm	HD - High temp/mark free material	60 G2M - G1/4 male thread
	50 - φ50mm		M10M - M10×1.5 male thread
	60 - φ60mm		M14M - M14×1.5 male thread
	80 - φ80mm		RA - Rectangular adapter
	100 - φ100mm		
	125 - φ125mm		

### Selection

Model	Connection thread					
	G2M	M10M	M14M	G2F	G3F	RA
STC22N-□	STC22N-G2M	STC22N-M10M	STC22N-M14M	STC22N-G2F	STC22N-G3F	STC22N-RA
STC30N-□	STC30N-G2M	STC30N-M10M	STC30N-M14M	STC30N-G2F	STC30N-G3F	STC30N-RA
STC40N-□	STC40N-G2M	STC40N-M10M	STC40N-M14M	STC40N-G2F	STC40N-G3F	STC40N-RA
STC50N-□	STC50N-G2M	STC50N-M10M	STC50N-M14M	STC50N-G2F	STC50N-G3F	STC50N-RA
STC60N-□	STC60N-G2M	STC60N-M10M	STC60N-M14M	STC60N-G2F	STC60N-G3F	STC60N-RA
STC80N-□	STC80N-G2M	STC80N-M10M	STC80N-M14M	STC80N-G2F	STC80N-G3F	STC80N-RA
STC100N-□	STC100N-G2M	STC100N-M10M	STC100N-M14M	STC100N-G2F	STC100N-G3F	STC100N-RA
STC125N-□	STC125N-G2M	STC125N-M10M	STC125N-M14M	STC125N-G2F	STC125N-G3F	STC125N-RA

Model	Connection thread			Model	Connection thread		
	G2M	G2F	G3F		G2M	G2F	G3F
STC22HK-□	STC22HK-G2M	STC22HK-G2F	STC22HK-G3F	STC22HD-□	STC22HD-G2M	STC22HD-G2F	STC22HD-G3F
STC30HK-□	STC30HK-G2M	STC30HK-G2F	STC30HK-G3F	STC30HD-□	STC30HD-G2M	STC30HD-G2F	STC30HD-G3F
STC40HK-□	STC40HK-G2M	STC40HK-G2F	STC40HK-G3F	STC40HD-□	STC40HD-G2M	STC40HD-G2F	STC40HD-G3F
STC50HK-□	STC50HK-G2M	STC50HK-G2F	STC50HK-G3F	STC50HD-□	STC50HD-G2M	STC50HD-G2F	STC50HD-G3F
STC60HK-□	STC60HK-G2M	STC60HK-G2F	STC60HK-G3F	STC60HD-□	STC60HD-G2M	STC60HD-G2F	STC60HD-G3F
STC80HK-□	STC80HK-G2M	STC80HK-G2F	STC80HK-G3F	STC80HD-□	STC80HD-G2M	STC80HD-G2F	STC80HD-G3F
STC100HK-□	STC100HK-G2M	STC100HK-G2F	STC100HK-G3F	STC100HD-□	STC100HD-G2M	STC100HD-G2F	STC100HD-G3F
STC125HK-□	STC125HK-G2M	STC125HK-G2F	STC125HK-G3F	STC125HD-□	STC125HD-G2M	STC125HD-G2F	STC125HD-G3F

- SZ
- SPH
- SP3
- SUF
- SAN
- SAO
- SOFA
- STP
- SFT
- SFA
- SBT
- SBL
- SBLP
- SBS
- SFP
- SBP
- SXP
- SGP
- SBOF
- STC
- SFF
- SOB
- SOF
- SOG
- SFM
- SOM
- SBF
- SDM
- SFU
- SFK
- SHT
- SDL
- SFG
- SFGT
- SFD
- SB
- SBA
- SF
- SU
- SP2F
- SPA
- SPD
- SPF
- SPC
- SPJ
- SPU
- SH
- SHB
- SBB
- SOP
- SNP

# STC Series



## 1.5 Bellows Suction Cup Special for Metal Sheet

### Technical parameters

Model	Vertical pull-out force N	Lateral pull-out force N	Lateral pull-out force Oily surface (N)	Inner volume cm <sup>3</sup>	Min.curve radius of workpiece mm	Weight g	Recommended hose dia. mm	MPQ pcs
STC22	23	20	6.5	1.5	20	8.6	6	5
STC30	35	28	12	6.3	35	12	6	5
STC40	62	37	34	7.2	40	13.5	6	1
STC50	85	58	55	11.2	45	21	8	1
STC60	141	88	83	22.5	52	29	8	1
STC80	236	141	136	57	70.5	51	8	1
STC100	371	228	221	92	95	77	8	1
STC125	558	352	335	191	140	165	10	1

◇ Note: Testing vacuum level -60kPa, workpiece with smooth and clean surface. The data of pull-out force as above are figured out without considering safety factor. The data may be different according to different workpiece surfaces

### Dimensions(mm)

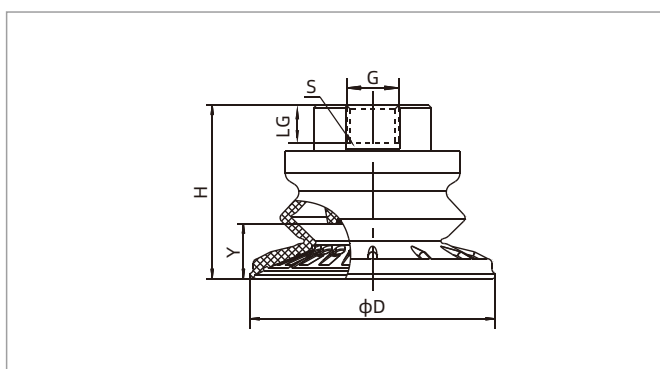

F - Female thread

Model/Size	D	H	G	LG	S	Y
STC22□-G2F	22	25	G1/4	10	16	5.5
STC30□-G2F	32	28	G1/4	11	17	9.5
STC40□-G2F	42	28.5	G1/4	11	17	10
STC50□-G3F	52	36.2	G3/8	13	22	11.5
STC60□-G3F	62.5	41	G3/8	13	22	14.5
STC80□-G3F	82	49.5	G3/8	13	22	22.5
STC100□-G3F	103	55	G3/8	13	22	25
STC125□-G3F	128	68	G3/8	13	22	32

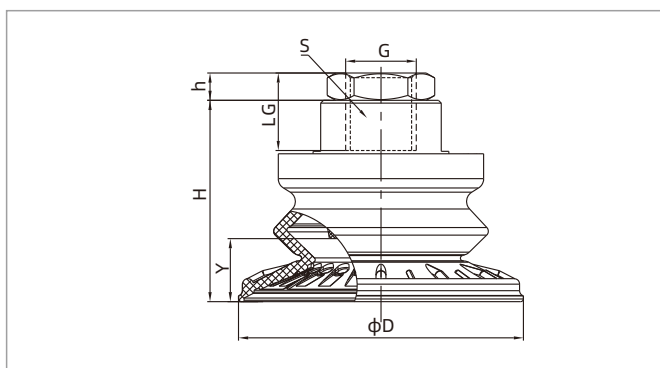

F - Female thread

Model/Size	D	H	G	h	LG	S	Y
STC22□-G3F	22	25	G3/8	14	11	22	5.5
STC30□-G3F	32	28	G3/8	14	11	22	9.5
STC40□-G3F	42	28.5	G3/8	14	11	22	10
STC50□-G2F	52	36.2	G1/4	5	13	9	11.5
STC60□-G2F	62.5	41	G1/4	5	13	9	14.5
STC80□-G2F	82	49.5	G1/4	5	13	9	22.5
STC100□-G2F	103	55	G1/4	5	13	9	25
STC125□-G2F	128	68	G1/4	5	13	9	32

# STC Series

## 1.5 Bellows Suction Cup Special for Metal Sheet



### Dimensions(mm)

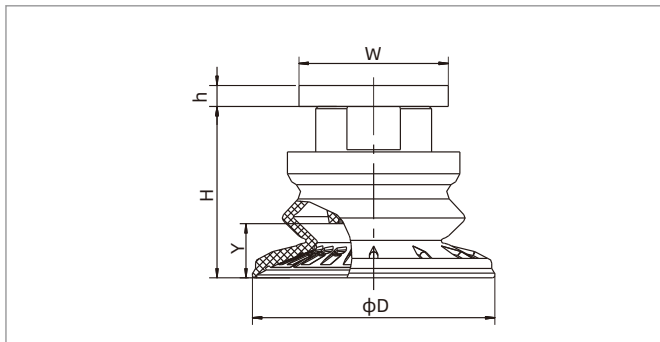

RA - Rectangular adapter

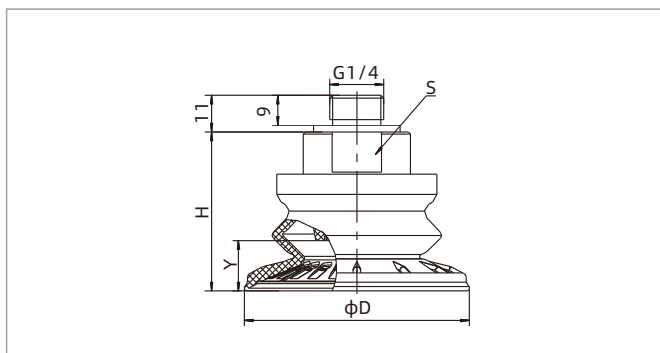

M - Male thread

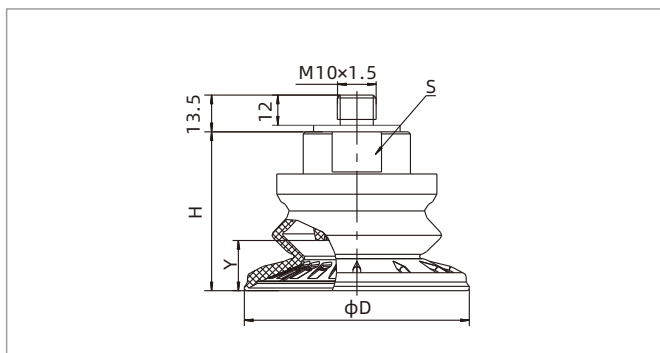

M - Male thread

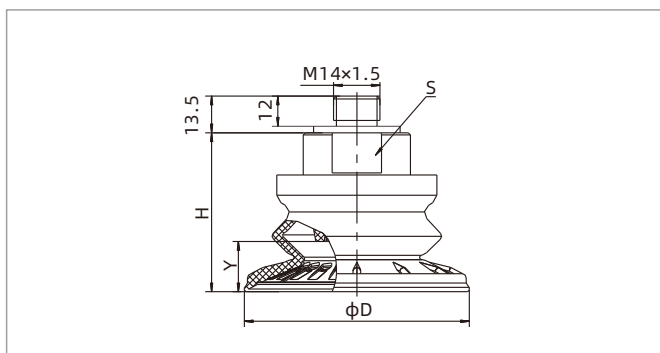

M - Male thread

◇ Note: The dimensional tolerance conforms to GB/T3672.1-2002-1 M3 rubber product dimensional tolerance standard

Model/Size	D	H	W	h	Y
STC22□-RA	22	25	31.8×31.8	4.7	5.5
STC30□-RA	32	28	31.8×31.8	4.7	9.5
STC40□-RA	42	28.5	31.8×31.8	4.7	10
STC50□-RA	52	36.2	31.8×31.8	4.7	11.5
STC60□-RA	62.5	41	31.8×31.8	4.7	14.5
STC80□-RA	82	49.5	31.8×31.8	4.7	22.5
STC100□-RA	103	55	31.8×31.8	4.7	25
STC125□-RA	128	68	31.8×31.8	4.7	32

Model/Size	D	H	S	Y
STC22□-G2M	22	25	17	5.5
STC30□-G2M	32	28	17	9.5
STC40□-G2M	42	28.5	17	10
STC50□-G2M	52	36.2	22	11.5
STC60□-G2M	62.5	41	22	14.5
STC80□-G2M	82	49.5	22	22.5
STC100□-G2M	103	55	22	25
STC125□-G2M	128	68	22	32

Model/Size	D	H	S	Y
STC22□-M10M	22	25	17	5.5
STC30□-M10M	32	28	17	9.5
STC40□-M10M	42	28.5	17	10
STC50□-M10M	52	36.2	22	11.5
STC60□-M10M	62.5	41	22	14.5
STC80□-M10M	82	49.5	22	22.5
STC100□-M10M	103	55	22	25
STC125□-M10M	128	68	22	32

Model/Size	D	H	S	Y
STC22□-M14M	22	25	17	5.5
STC30□-M14M	32	28	17	9.5
STC40□-M14M	42	28.5	17	10
STC50□-M14M	52	36.2	22	11.5
STC60□-M14M	62.5	41	22	14.5
STC80□-M14M	82	49.5	22	22.5
STC100□-M14M	103	55	22	25
STC125□-M14M	128	68	22	32

- SZ
- SPH
- SP3
- SUF
- SAN
- SAO
- SOFA
- STP
- SFT
- SFA
- SBT
- SBL
- SBLP
- SBS
- SFP
- SBP
- SXP
- SGP
- SBOF
- STC
- SFF
- SOB
- SOF
- SOG
- SFM
- SOM
- SBF
- SDM
- SFU
- SFK
- SHT
- SDL
- SFG
- SFGT
- SFD
- SB
- SBA
- SF
- SU
- SP2F
- SPA
- SPD
- SPF
- SPC
- SPJ
- SPU
- SH
- SHB
- SBB
- SOP
- SNP

# SFF Series

AIRBEST

## Flat Suction Cup Special for Metal Sheet



METAL SHEET



SLIPPING RESISTANCE



OILY SURFACE



### Features

- ◇ Internal large area support structure
- ◇ Various sizes are available

### Advantages

- ◇ Effectively enhance the friction force between suction cups and workpieces
- ◇ The max. temp of HK material is 250°C, it can be used to pick up high temp metal sheet
- ◇ The max. temp of HD material is 160°C, it can be used to pick up high temp glass without mark
- ◇ Suitable for workpieces with different sizes and shapes



### Applications

- ◇ Handling of oily metal sheet
- ◇ Handling metal sheet and aluminum plates without deformation
- ◇ Used for loading and unloading of material during CNC or machine tool processing
- ◇ Handling curved metal sheets
- ◇ Used in automotive stamping metal parts handling systems

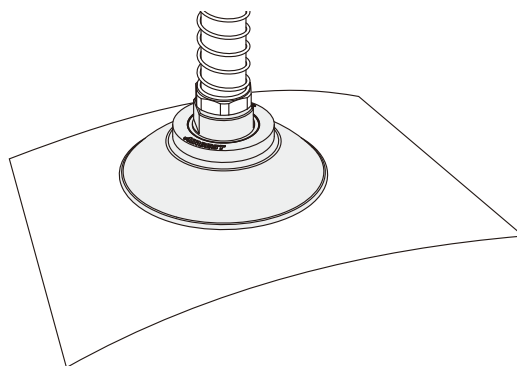

### Structure

- ◇ Suction cup and fitting are one-piece structure

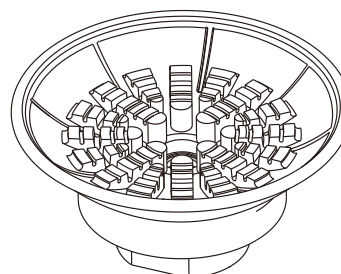

# SFF Series

## Flat Suction Cup Speical for Metal Sheet

### How to order

## SFF 50 N - G3F

① ② ③ ④

① Series	② Diameter	③ Material & Hardness	④ Connection thread
SFF	30 - φ30mm	N - NBR	60 G2F - G1/4 female thread
	40 - φ40mm	NG - NBR	45 G3F - G3/8 female thread
	50 - φ50mm	HK - Extra high temp rubber	65 G2M - G1/4 male thread
	60 - φ60mm	HD - High temp/mark free material	60 M10M - M10×1.5 male thread
	80 - φ80mm		M14M - M14×1.5 male thread
	100 - φ100mm		RA - Rectangular adapter
	125 - φ125mm		

### Selection

Model	Connection thread					
	G2M	M10M	M14M	G2F	G3F	RA
SFF30N-□	SFF30N-G2M	SFF30N-M10M	SFF30N-M14M	SFF30N-G2F	SFF30N-G3F	SFF30N-RA
SFF40N-□	SFF40N-G2M	SFF40N-M10M	SFF40N-M14M	SFF40N-G2F	SFF40N-G3F	SFF40N-RA
SFF50N-□	SFF50N-G2M	SFF50N-M10M	SFF50N-M14M	SFF50N-G2F	SFF50N-G3F	SFF50N-RA
SFF60N-□	SFF60N-G2M	SFF60N-M10M	SFF60N-M14M	SFF60N-G2F	SFF60N-G3F	SFF60N-RA
SFF80N-□	SFF80N-G2M	SFF80N-M10M	SFF80N-M14M	SFF80N-G2F	SFF80N-G3F	SFF80N-RA
SFF100N-□	SFF100N-G2M	SFF100N-M10M	SFF100N-M14M	SFF100N-G2F	SFF100N-G3F	SFF100N-RA
SFF125N-□	SFF125N-G2M	SFF125N-M10M	SFF125N-M14M	SFF125N-G2F	SFF125N-G3F	SFF125N-RA

Model	Connection thread					
	G2M	M10M	M14M	G2F	G3F	RA
SFF30NG-□	SFF30NG-G2M	SFF30NG-M10M	SFF30N-M14M	SFF30NG-G2F	SFF30NG-G3F	SFF30NG-RA
SFF40NG-□	SFF40NG-G2M	SFF40NG-M10M	SFF40N-M14M	SFF40NG-G2F	SFF40NG-G3F	SFF40NG-RA
SFF50NG-□	SFF50NG-G2M	SFF50NG-M10M	SFF50N-M14M	SFF50NG-G2F	SFF50NG-G3F	SFF50NG-RA
SFF60NG-□	SFF60NG-G2M	SFF60NG-M10M	SFF60N-M14M	SFF60NG-G2F	SFF60NG-G3F	SFF60NG-RA
SFF80NG-□	SFF80NG-G2M	SFF80NG-M10M	SFF80N-M14M	SFF80NG-G2F	SFF80NG-G3F	SFF80NG-RA
SFF100NG-□	SFF100NG-G2M	SFF100NG-M10M	SFF100N-M14M	SFF100NG-G2F	SFF100NG-G3F	SFF100NG-RA
SFF125NG-□	SFF125NG-G2M	SFF125NG-M10M	SFF125N-M14M	SFF125NG-G2F	SFF125NG-G3F	SFF125NG-RA

Model	Connection thread			Model	Connection thread		
	G2M	G2F	G3F		G2M	G2F	G3F
SFF30HK-□	SFF30HK-G2M	SFF30HK-G2F	SFF30HK-G3F	SFF30HD-□	SFF30HD-G2M	SFF30HD-G2F	SFF30HD-G3F
SFF40HK-□	SFF40HK-G2M	SFF40HK-G2F	SFF40HK-G3F	SFF40HD-□	SFF40HD-G2M	SFF40HD-G2F	SFF40HD-G3F
SFF50HK-□	SFF50HK-G2M	SFF50HK-G2F	SFF50HK-G3F	SFF50HD-□	SFF50HD-G2M	SFF50HD-G2F	SFF50HD-G3F
SFF60HK-□	SFF60HK-G2M	SFF60HK-G2F	SFF60HK-G3F	SFF60HD-□	SFF60HD-G2M	SFF60HD-G2F	SFF60HD-G3F
SFF80HK-□	SFF80HK-G2M	SFF80HK-G2F	SFF80HK-G3F	SFF80HD-□	SFF80HD-G2M	SFF80HD-G2F	SFF80HD-G3F
SFF100HK-□	SFF100HK-G2M	SFF100HK-G2F	SFF100HK-G3F	SFF100HD-□	SFF100HD-G2M	SFF100HD-G2F	SFF100HD-G3F
SFF125HK-□	SFF125HK-G2M	SFF125HK-G2F	SFF125HK-G3F	SFF125HD-□	SFF125HD-G2M	SFF125HD-G2F	SFF125HD-G3F

- SZ
- SPH
- SP3
- SUF
- SAN
- SAO
- SOFA
- STP
- SFT
- SFA
- SBT
- SBL
- SBLP
- SBS
- SFP
- SBP
- SXP
- SGP
- SBOF
- STC
- SFF
- SOB
- SOF
- SOG
- SFM
- SOM
- SBF
- SDM
- SFU
- SKF
- SHT
- SDL
- SFG
- SFGT
- SFD
- SB
- SBA
- SF
- SU
- SP2F
- SPA
- SPD
- SPF
- SPC
- SPJ
- SPU
- SH
- SHB
- SBB
- SOP
- SNP

# SFF Series

## Flat Suction Cup Special for Metal Sheet

### Technical parameters

Model	Vertical pull-out force N	Lateral pull-out force N	Lateral pull-out force Oily surface(N)	Inner volume cm <sup>3</sup>	Min.curve radius of workpiece mm	Weight g	Recommended hose dia. mm	MPQ pcs
SFF30	45	35	33	1.6	35	11	6	1
SFF40	72	54	51	3.5	47.5	13	6	1
SFF50	112	90	86	7.5	70	20	8	1
SFF60	145	102	93	12.6	81	26	8	1
SFF80	288	212	190	35	115	43	8	1
SFF100	445	322	308	60	141	57	8	1
SFF125	660	475	400	115	165	145	10	1

### Dimensions(mm)

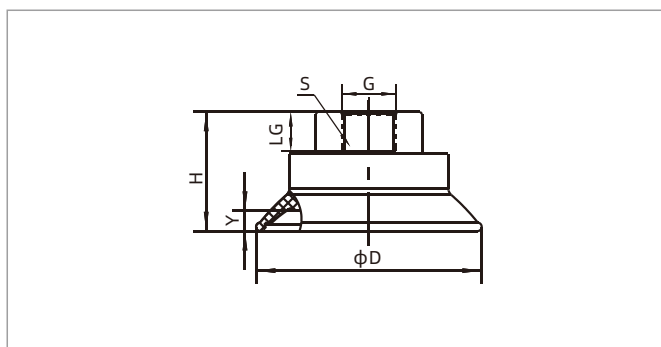

Model/Size	D	H	G	LG	S	Y
SFF30□-G2F	32	19.5	G1/4	11	17	2.7
SFF40□-G2F	42	22	G1/4	11	17	3.4
SFF50□-G3F	52	28	G3/8	13	22	4.7
SFF60□-G3F	62.5	31	G3/8	13	22	6
SFF80□-G3F	83	34.5	G3/8	13	22	6
SFF100□-G3F	102	36.5	G3/8	13	22	9.2
SFF125□-G3F	128	43	G3/8	13	22	12.5

F - Female thread connection

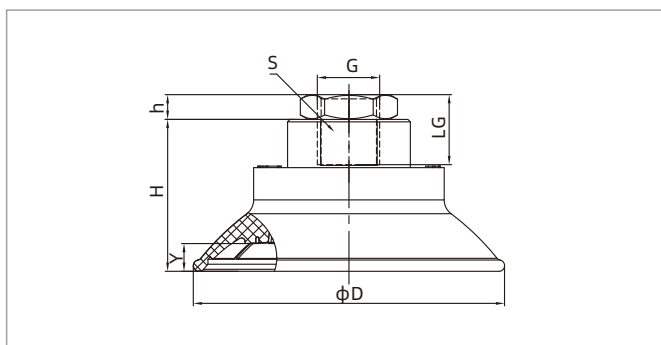

Model/Size	D	H	G	h	LG	S	Y
SFF30□-G3F	32	19.5	G3/8	14	11	22	2.7
SFF40□-G3F	42	22	G3/8	14	11	22	3.4
SFF50□-G2F	52	28	G1/4	5	13	19	4.7
SFF60□-G2F	62.5	31	G1/4	5	13	19	6
SFF80□-G2F	83	34.5	G1/4	5	13	19	6
SFF100□-G2F	102	36.5	G1/4	5	13	19	9.2
SFF125□-G2F	128	43	G1/4	5	13	19	12.5

F - Female thread connection

# SFF Series

## Flat Suction Cup Special for Metal Sheet

### Dimensions(mm)

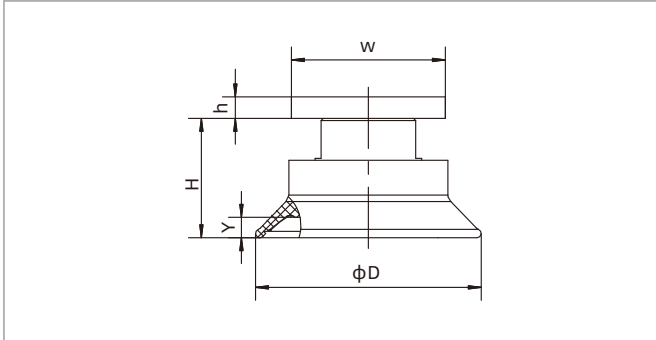

RA - Rectangular adapter

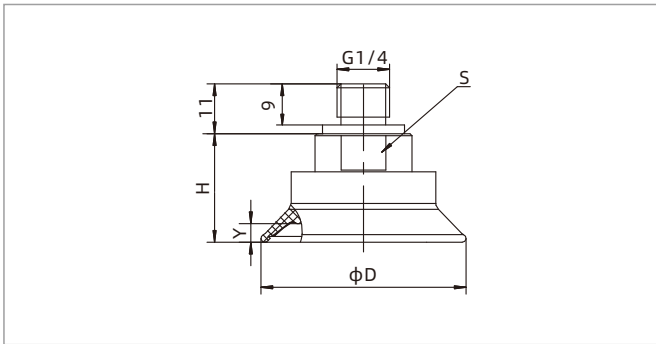

M - Male thread connection

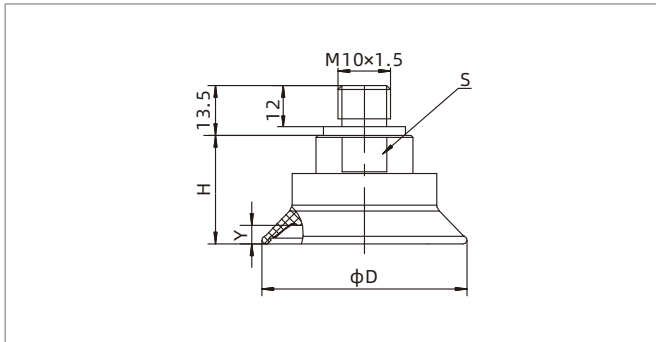

M - Male thread connection

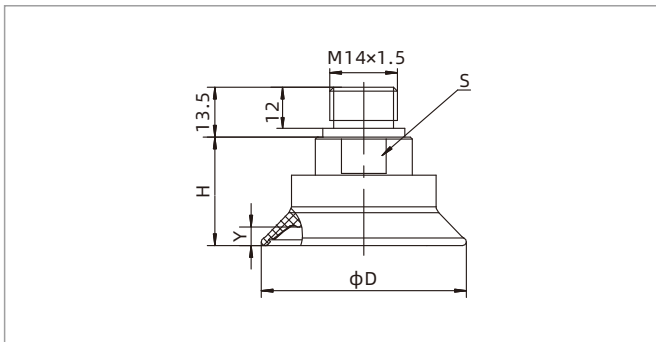

M - Male thread connection

◇ Note: The dimensional tolerance conforms to GBT3672.1-2002-1 M3 rubber product dimensional tolerance standard

Model/Size	D	H	W	h	Y
SFF30□-RA	32	19.5	31.8×31.8	4.7	2.7
SFF40□-RA	42	22	31.8×31.8	4.7	3.7
SFF50□-RA	52	28	31.8×31.8	4.7	4.7
SFF60□-RA	62.5	31	31.8×31.8	4.7	6
SFF80□-RA	83	34.5	31.8×31.8	4.7	6
SFF100□-RA	102	36.5	31.8×31.8	4.7	9.2
SFF125□-RA	128	43	31.8×31.8	4.7	12.5

Model/Size	D	H	s	Y
SFF30□-G2M	32	19.5	17	2.7
SFF40□-G2M	42	22	17	3.7
SFF50□-G2M	52	28	22	4.7
SFF60□-G2M	62.5	31	22	6
SFF80□-G2M	83	34.5	22	6
SFF100□-G2M	102	36.5	22	9.2
SFF125□-G2M	128	43	22	12.5

Model/Size	D	H	s	Y
SFF30□-M10M	32	19.5	17	2.7
SFF40□-M10M	42	22	17	3.7
SFF50□-M10M	52	28	22	4.7
SFF60□-M10M	62.5	31	22	6
SFF80□-M10M	83	34.5	22	6
SFF100□-M10M	102	36.5	22	9.2
SFF125□-M10M	128	43	22	12.5

Model/Size	D	H	s	Y
SFF30□-M14M	32	19.5	17	2.7
SFF40□-M14M	42	22	17	3.7
SFF50□-M14M	52	28	22	4.7
SFF60□-M14M	62.5	31	22	6
SFF80□-M14M	83	34.5	22	6
SFF100□-M14M	102	36.5	22	9.2
SFF125□-M14M	128	43	22	12.5

- SZ
- SPH
- SP3
- SUF
- SAN
- SAO
- SOFA
- STP
- SFT
- SFA
- SBT
- SBL
- SBLP
- SBS
- SFP
- SBP
- SXP
- SGP
- SBOF
- STC
- SFF**
- SOB
- SOF
- SOG
- SFM
- SOM
- SBF
- SDM
- SFU
- SFK
- SHT
- SDL
- SFG
- SFGT
- SFD
- SB
- SBA
- SF
- SU
- SP2F
- SPA
- SPD
- SPF
- SPC
- SPJ
- SPU
- SH
- SHB
- SBB
- SOP
- SNP

# SOB Series

## Oval Suction Cup Special for Metal Sheet

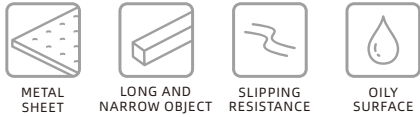

### Features

- ◇ 1.5 Bellows oval structure
- ◇ Internal large area pattern support structure
- ◇ Various sizes and specifications are available

### Advantages

- ◇ Handling long and narrow workpieces with even surface or curvature
- ◇ The max. temp of HK material is 250°C, it can be used to pick up high temp metal sheet
- ◇ The max. temp of HD material is 160°C, it can be used to pick up high temp glass without mark
- ◇ Suitable for workpieces with different sizes and shapes



### Applications

- ◇ Handling narrow and long metal parts in fast speed, short cycle time
- ◇ Handling metal sheet and aluminum plates without deformation
- ◇ Handling automotive stamping metal parts

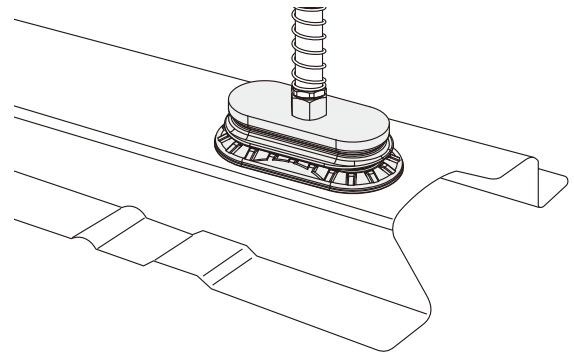

### Structure

- ◇ 1.5 Bellows structure
- ◇ Suction cup and fitting are one-piece structure

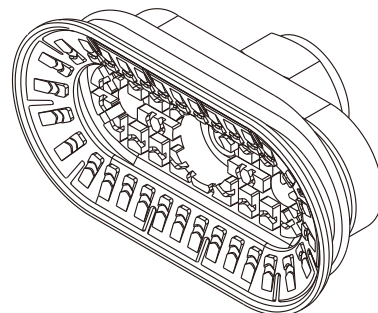

# SOB Series

## Oval Suction Cup Special for Metal Sheet

### How to order

## SOB 30×60 N - G3F

①                      ②                      ③                      ④

① Series	② Size	③ Material & Hardness	④ Connection thread
SOB	30×60	N - NBR	<span style="background-color: #ff9933; padding: 2px;">60</span> G2F - G1/4 female thread
	40×80	HK - Extra high temp rubber	<span style="background-color: #333333; color: white; padding: 2px;">65</span> G3F - G3/8 female thread
	55×110	HD - High temp/mark free material	<span style="background-color: #006699; color: white; padding: 2px;">60</span> G2M - G1/4 male thread
	70×140		M10M - M10×1.5 male thread M14M - M14×1.5 male thread RA - Rectangular adapter

### Selection

Model	Connection thread					
	G2M	M10M	M14M	G2F	G3F	RA
SOB30×60N-□	SOB30×60N-G2M	SOB30×60N-M10M	SOB30×60N-M14M	SOB30×60N-G2F	SOB30×60N-G3F	SOB30×60N-RA
SOB40×80N-□	SOB40×80N-G2M	SOB40×80N-M10M	SOB40×80N-M14M	SOB40×80N-G2F	SOB40×80N-G3F	SOB40×80N-RA
SOB55×110N-□	SOB55×110N-G2M	SOB55×110N-M10M	SOB55×110N-M14M	SOB55×110N-G2F	SOB55×110N-G3F	SOB55×110N-RA
SOB70×140N-□	SOB70×140N-G2M	SOB70×140N-M10M	SOB70×140N-M14M	SOB70×140N-G2F	SOB70×140N-G3F	SOB70×140N-RA

Model	Connection thread		
	G2M	G2F	G3F
SOB30×60HK-□	SOB30×60HK-G2M	SOB30×60HK-G2F	SOB30×60HK-G3F
SOB40×80HK-□	SOB40×80HK-G2M	SOB40×80HK-G2F	SOB40×80HK-G3F
SOB55×110HK-□	SOB55×110HK-G2M	SOB55×110HK-G2F	SOB55×110HK-G3F
SOB70×140HK-□	SOB70×140HK-G2M	SOB70×140HK-G2F	SOB70×140HK-G3F

Model	Connection thread		
	G2M	G2F	G3F
SOB30×60HD-□	SOB30×60HD-G2M	SOB30×60HD-G2F	SOB30×60HD-G3F
SOB40×80HD-□	SOB40×80HD-G2M	SOB40×80HD-G2F	SOB40×80HD-G3F
SOB55×110HD-□	SOB55×110HD-G2M	SOB55×110HD-G2F	SOB55×110HD-G3F
SOB70×140HD-□	SOB70×140HD-G2M	SOB70×140HD-G2F	SOB70×140HD-G3F

### Technical parameters

Model	Vertical pull-out force N	Lateral pull-out force N	Lateral pull-out force (Oily surface)N	Inner volume cm <sup>3</sup>	Min.curve radius of workpiece mm	Weight g	Recommended hose dia. mm	MPQ pcs
SOB30×60	53	60	50	8.7	25	26	6	1
SOB40×80	110	118	101	20	32	33	8	1
SOB55×110	197	200	183	50	50	75	8	1
SOB70×140	275	295	267	100	70	117	8	1

◇ Note: Testing vacuum level -60kPa, workpiece with smooth and clean surface. The data of pull-out force as above are figured out without considering safety factor. The data may be different according to different workpiece surfaces

- SZ
- SPH
- SP3
- SUF
- SAN
- SAO
- SOFA
- STP
- SFT
- SFA
- SBT
- SBL
- SBLP
- SBS
- SFP
- SBP
- SXP
- SGP
- SOBF
- STC
- SFF
- SOB**
- SOF
- SOG
- SFM
- SOM
- SBF
- SDM
- SFU
- SFK
- SHT
- SDL
- SFG
- SFGT
- SFD
- SB
- SBA
- SF
- SU
- SP2F
- SPA
- SPD
- SPF
- SPC
- SPJ
- SPU
- SH
- SHB
- SBB
- SOP
- SNP

# SOB Series

## Oval Suction Cup Special for Metal Sheet



### Dimensions(mm)

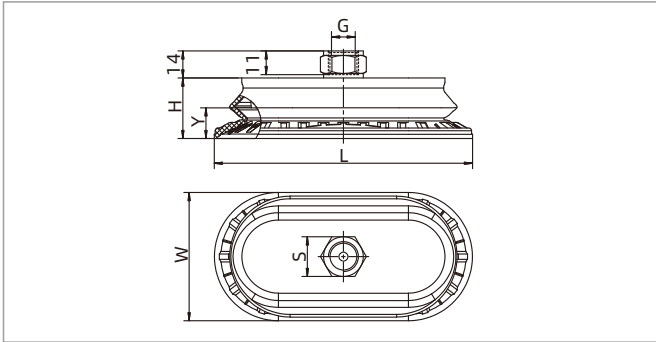

F - Female thread connection

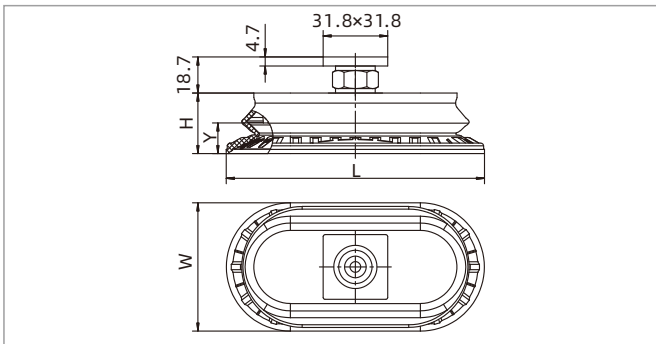

RA - Rectangular adapter

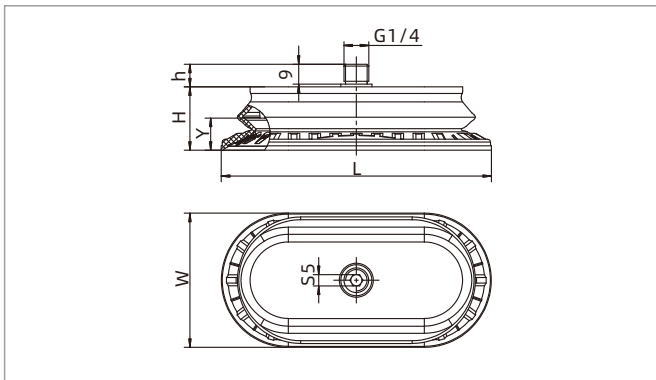

M - Male thread connection

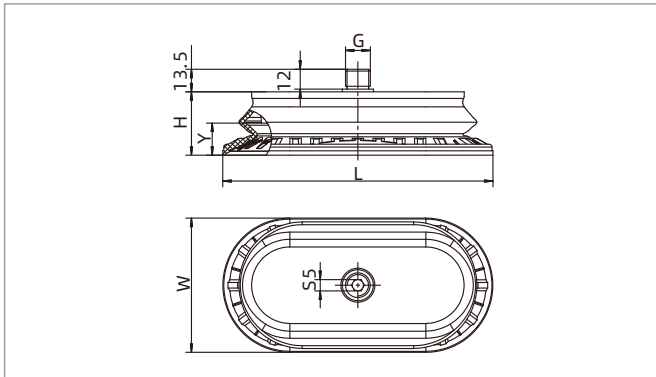

M - Male thread connection

◇ Note: The dimensional tolerance conforms to GBT3672.1-2002-1 M3 rubber product dimensional tolerance standard

Model/Size	L	W	H	G	S	Y
SOB30×60N-G2F	62	31	20	G1/4	17	6
SOB30×60N-G3F	62	31	20	G3/8	22	6
SOB40×80N-G2F	82	41	22.7	G1/4	17	8.8
SOB40×80N-G3F	82	41	22.7	G3/8	22	8.8
SOB55×110N-G2F	112	57	29	G1/4	17	12.5
SOB55×110N-G3F	112	57	29	G3/8	22	12.5
SOB70×140N-G2F	143	70.5	33	G1/4	17	17
SOB70×140N-G3F	143	70.5	33	G3/8	22	17

Model/Size	L	W	H	Y
SOB30×60N-RA	62	31	20	6
SOB40×80N-RA	82	41	22.7	8.8
SOB55×110N-RA	112	57	29	12.5
SOB70×140N-RA	143	70.5	33	17

Model/Size	L	W	H	h	Y
SOB30×60N-G2M	62	31	20	10.5	6
SOB40×80N-G2M	82	41	22.7	10.5	8.8
SOB55×110N-G2M	112	57	29	11	12.5
SOB70×140N-G2M	143	70.5	33	11	17

Model/Size	L	W	H	G	Y
SOB30×60N-M10M	62	31	20	M10×1.5	6
SOB30×60N-M14M	62	31	20	M14×1.5	6
SOB40×80-M10M	82	41	22.7	M10×1.5	8.8
SOB40×80N-M14M	82	41	22.7	M14×1.5	8.8
SOB55×110-M10M	112	57	29	M10×1.5	12.5
SOB55×110N-M14M	112	57	29	M14×1.5	12.5
SOB70×140-M10M	143	70.5	33	M10×1.5	17
SOB70×140N-M14M	143	70.5	33	M14×1.5	17

# SOF Series

## Oval Flat Suction Cup Special for Metal Sheet

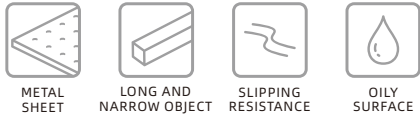

### Features

- ◇ Oval flat suction cup
- ◇ Internal large area pattern support structure
- ◇ Various sizes are available

### Advantages

- ◇ Handling long and narrow workpieces
- ◇ Effectively enhance friction force between suction cups and workpieces
- ◇ The max. temp of HK material is 250°C, it can be used to pick up high temp metal sheet
- ◇ The max. temp of HD material is 160°C, it can be used to pick up high temp glass without mark
- ◇ Suitable for workpieces with different sizes and shapes



### Applications

- ◇ Handling narrow and long metal parts in fast speed, short cycle time
- ◇ Handling metal sheet and aluminum plates without deformation
- ◇ Handling automotive stamping metal parts

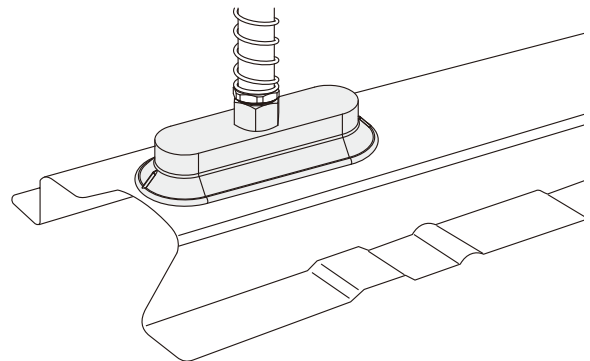

### Structure

- ◇ Suction cup and fitting are one-piece structure

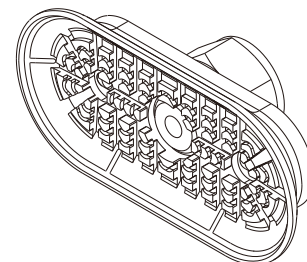

- SZ
- SPH
- SP3
- SUF
- SAN
- SAO
- SOFA
- STP
- SFT
- SFA
- SBT
- SBL
- SBLP
- SBS
- SFP
- SBP
- SXP
- SGP
- SBOF
- STC
- SFF
- SOB
- SOF**
- SOG
- SFM
- SOM
- SBF
- SDM
- SFU
- SFK
- SHT
- SDL
- SFG
- SFGT
- SFD
- SB
- SBA
- SF
- SU
- SP2F
- SPA
- SPD
- SPF
- SPC
- SPJ
- SPU
- SH
- SHB
- SBB
- SOP
- SNP

## Oval Flat Suction Cup Speical for Metal Sheet

### How to order

## SOF 40×80 N - G3F

①                      ②                      ③                      ④

① Series	② Size	③ Material & Hardness	④ Connection thread
SOF	16×50 40×110	N - NBR	<b>60</b> G2F - G1/4 female thread M10M - M10×1.5 male thread
	20×80 50×100	NG - NBR	<b>45</b> G3F - G3/8 female thread M14M - M14×1.5 male thread
	23×60 60×120	HK - Extra high temp rubber	<b>65</b> G2M - G1/4 male thread RA - Rectangular adapter
	30×90 70×140	HD - High temp/mark free material	<b>60</b>
	40×80		

### Selection

Model	Connection thread					
	G2M	M10M	M14M	G2F	G3F	RA
SOF16×50□-□	SOF16×50□-G2M	SOF16×50□-M10M	SOF16×50□-M14M	SOF16×50□-G2F	SOF16×50□-G3F	SOF16×50□-RA
SOF20×80□-□	SOF20×80□-G2M	SOF20×80□-M10M	SOF20×80□-M14M	SOF20×80□-G2F	SOF20×80□-G3F	SOF20×80□-RA
SOF23×60□-□	SOF23×60□-G2M	SOF23×60□-M10M	SOF23×60□-M14M	SOF23×60□-G2F	SOF23×60□-G3F	SOF23×60□-RA
SOF40×80□-□	SOF40×80□-G2M	SOF40×80□-M10M	SOF40×80□-M14M	SOF40×80□-G2F	SOF40×80□-G3F	SOF40×80□-RA
SOF30×90□-□	SOF30×90□-G2M	SOF30×90□-M10M	SOF30×90□-M14M	SOF30×90□-G2F	SOF30×90□-G3F	SOF30×90□-RA
SOF40×110□-□	SOF40×110□-G2M	SOF40×110□-M10M	SOF40×110□-M14M	SOF40×110□-G2F	SOF40×110□-G3F	SOF40×110□-RA
SOF50×100□-□	SOF50×100□-G2M	SOF50×100□-M10M	SOF50×100□-M14M	SOF50×100□-G2F	SOF50×100□-G3F	SOF50×100□-RA
SOF60×120□-□	SOF60×120□-G2M	SOF60×120□-M10M	SOF60×120□-M14M	SOF60×120□-G2F	SOF60×120□-G3F	SOF60×120□-RA
SOF70×140□-□	SOF70×140□-G2M	SOF70×140□-M10M	SOF70×140□-M14M	SOF70×140□-G2F	SOF70×140□-G3F	SOF70×140□-RA

Model	Connection thread			Model	Connection thread		
	G2M	G2F	G3F		G2M	G2F	G3F
SOF16×50HK-□	SOF16×50HK-G2M	SOF16×50HK-G2F	SOF16×50HK-G3F	SOF16×50HD-□	SOF16×50HD-G2M	SOF16×50HD-G2F	SOF16×50HD-G3F
SOF20×80HK-□	SOF20×80HK-G2M	SOF20×80HK-G2F	SOF20×80HK-G3F	SOF20×80HD-□	SOF20×80HD-G2M	SOF20×80HD-G2F	SOF20×80HD-G3F
SOF23×60HK-□	SOF23×60HK-G2M	SOF23×60HK-G2F	SOF23×60HK-G3F	SOF23×60HD-□	SOF23×60HD-G2M	SOF23×60HD-G2F	SOF23×60HD-G3F
SOF40×80HK-□	SOF40×80HK-G2M	SOF40×80HK-G2F	SOF40×80HK-G3F	SOF40×80HD-□	SOF40×80HD-G2M	SOF40×80HD-G2F	SOF40×80HD-G3F
SOF30×90HK-□	SOF30×90HK-G2M	SOF30×90HK-G2F	SOF30×90HK-G3F	SOF30×90HD-□	SOF30×90HD-G2M	SOF30×90HD-G2F	SOF30×90HD-G3F
SOF40×110HK-□	SOF40×110HK-G2M	SOF40×110HK-G2F	SOF40×110HK-G3F	SOF40×110HD-□	SOF40×110HD-G2M	SOF40×110HD-G2F	SOF40×110HD-G3F
SOF50×100HK-□	SOF50×100HK-G2M	SOF50×100HK-G2F	SOF50×100HK-G3F	SOF50×100HD-□	SOF50×100HD-G2M	SOF50×100HD-G2F	SOF50×100HD-G3F
SOF60×120HK-□	SOF60×120HK-G2M	SOF60×120HK-G2F	SOF60×120HK-G3F	SOF60×120HD-□	SOF60×120HD-G2M	SOF60×120HD-G2F	SOF60×120HD-G3F
SOF70×140HK-□	SOF70×140HK-G2M	SOF70×140HK-G2F	SOF70×140HK-G3F	SOF70×140HD-□	SOF70×140HD-G2M	SOF70×140HD-G2F	SOF70×140HD-G3F

### Technical parameters

Model	Vertical pull-out force N	Lateral pull-out force N	Lateral pull-out force (Oily surface)N	Inner volume cm <sup>3</sup>	Min.curve radius of workpiece mm	Weight g	Recommended hose dia. mm	MPQ pcs
SOF16×50	33	24	12	2	8	17	4	1
SOF20×80	78	38	35	5	25	23	4	1
SOF23×60	57	37	33	3	20	29	4	1
SOF30×90	125	77	60	10	30	24	4	1
SOF40×80	141	110	100	11	50	43	6	1
SOF40×110	200	188	118	25	35	47	6	1
SOF50×100	217	181	121	20	75	56	6	1
SOF60×120	312	254	170	35	75	70	6	1
SOF70×140	445	344	230	52	90	77	8	1

◇ Note: Testing vacuum level -60kPa, workpiece with smooth and clean surface. The data of pull-out force as above are figured out without considering safety factor. The data may be different according to different workpiece surfaces.

# SOF Series

## Oval Flat Suction Cup Special for Metal Sheet



### Dimensions(mm)

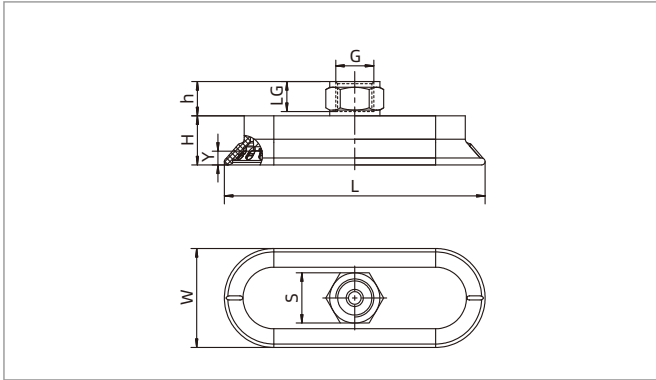

F - Female thread connection

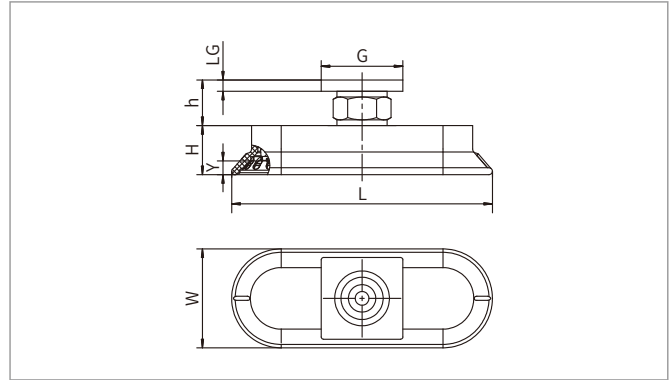

RA-Rectangular adapter

Model/Size	L	W	H	G	LG	h	S	Y
SOF16×50□-G2F	50	16	19.5	G1/4	11	14	17	3
SOF16×50□-G3F	50	16	19.5	G3/8	11	14	22	3
SOF16×50□-RA	50	16	19.5	31.8×31.8	4.7	18.7	-	3
SOF20×80□-G2F	84	24	15.5	G1/4	11	14	17	5
SOF20×80□-G3F	84	24	15.5	G3/8	11	14	22	5
SOF20×80□-RA	84	24	15.5	31.8×31.8	4.7	18.7	-	5
SOF23×60□-G2F	61.5	22.5	12	G1/4	11	14	17	3
SOF23×60□-G3F	61.5	22.5	12	G3/8	11	14	22	3
SOF23×60□-RA	61.5	22.5	12	31.8×31.8	4.7	18.7	-	3
SOF30×90□-G2F	93	33	16	G1/4	11	14	17	5
SOF30×90□-G3F	93	33	16	G3/8	11	14	22	5
SOF30×90□-RA	93	33	16	31.8×31.8	4.7	18.7	-	5
SOF40×80□-G2F	82	39	14	G1/4	11	14	17	4
SOF40×80□-G3F	82	39	14	G3/8	11	14	22	4
SOF40×80□-RA	82	39	14	31.8×31.8	4.7	18.7	-	4
SOF40×110□-G2F	113	43	21.5	G1/4	11	14	17	6
SOF40×110□-G3F	113	43	21.5	G3/8	11	14	22	6
SOF40×110□-RA	113	43	21.5	31.8×31.8	4.7	18.7	-	6
SOF50×100□-G2F	102	49	16	G1/4	11	14	17	5
SOF50×100□-G3F	102	49	16	G3/8	11	14	22	5
SOF50×100□-RA	102	49	16	31.8×31.8	4.7	18.7	-	5
SOF60×120□-G2F	123	58	18	G1/4	11	14	17	6
SOF60×120□-G3F	123	58	18	G3/8	11	14	22	6
SOF60×120□-RA	123	58	18	31.8×31.8	4.7	18.7	-	6
SOF70×140□-G2F	141	67.5	19	G1/4	11	14	17	7
SOF70×140□-G3F	141	67.5	19	G3/8	11	14	22	7
SOF70×140□-RA	141	67.5	19	31.8×31.8	4.7	18.7	-	7

- SZ
- SPH
- SP3
- SUF
- SAN
- SAO
- SOFA
- STP
- SFT
- SFA
- SBT
- SBL
- SBLP
- SBS
- SFP
- SBP
- SXP
- SGP
- SBOF
- STC
- SFF
- SOB
- SOF**
- SOG
- SFM
- SOM
- SBF
- SDM
- SFU
- SFK
- SHT
- SDL
- SFG
- SFGT
- SFD
- SB
- SBA
- SF
- SU
- SP2F
- SPA
- SPD
- SPF
- SPC
- SPJ
- SPU
- SH
- SHB
- SBB
- SOP
- SNP

# SOF Series

## Oval Flat Suction Cup Special for Metal Sheet

### Dimensions(mm)

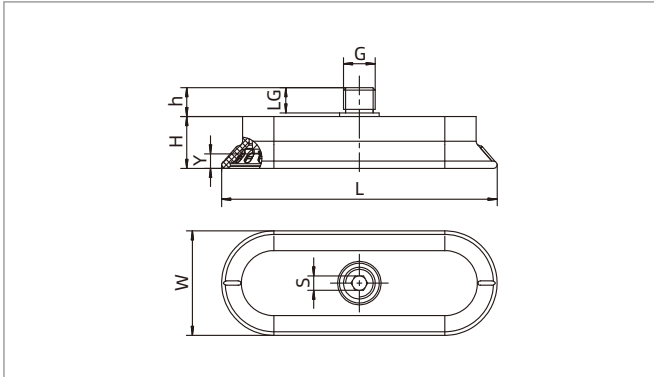

M - Male thread connection

Model/Size	L	W	H	G	LG	h	S	Y
SOF16×50□-G2M	50	16	19.5	G1/4	9	10.5	5	3
SOF16×50□-M10M	50	16	19.5	M10×1.5	12	13.5	5	3
SOF16×50□-M14M	50	16	19.5	M14×1.5	12	13.5	5	3
SOF20×80□-G2M	84	24	15.5	G1/4	9	10.5	5	5
SOF20×80□-M10M	84	24	15.5	M10×1.5	12	13.5	5	5
SOF20×80□-M14M	84	24	15.5	M14×1.5	12	13.5	5	5
SOF23×60□-G2M	61.5	22.5	12	G1/4	9	10.5	5	3
SOF23×60□-M10M	61.5	22.5	12	M10×1.5	12	13.5	5	3
SOF23×60□-M14M	61.5	22.5	12	M14×1.5	12	13.5	5	3
SOF30×90□-G2M	93	33	16	G1/4	9	10.5	5	5
SOF30×90□-M10M	93	33	16	M10×1.5	12	13.5	5	5
SOF30×90□-M14M	93	33	16	M14×1.5	12	13.5	5	5
SOF40×80□-G2M	82	39	14	G1/4	9	10.5	5	4
SOF40×80□-M10M	82	39	14	M10×1.5	12	13.5	5	4
SOF40×80□-M14M	82	39	14	M14×1.5	12	13.5	5	4
SOF40×110□-G2M	113	43	21.5	G1/4	9	11	5	6
SOF40×110□-M10M	113	43	21.5	M10×1.5	12	13.5	5	6
SOF40×110□-M14M	113	43	21.5	M14×1.5	12	13.5	5	6
SOF50×100□-G2M	102	49	16	G1/4	9	11	5	5
SOF50×100□-M10M	102	49	16	M10×1.5	12	13.5	5	5
SOF50×100□-M14M	102	49	16	M14×1.5	12	13.5	5	5
SOF60×120□-G2M	123	58	18	G1/4	9	11	5	6
SOF60×120□-M10M	123	58	18	M10×1.5	12	13.5	5	6
SOF60×120□-M14M	123	58	18	M14×1.5	12	13.5	5	6
SOF70×140□-G2M	141	67.5	19	G1/4	9	11	5	7
SOF70×140□-M10M	141	67.5	19	M10×1.5	12	13.5	5	7
SOF70×140□-M14M	141	67.5	19	M14×1.5	12	13.5	5	7

◇ Note: The dimensional tolerance conforms to GB/T3672.1-2002-1 M3 rubber product dimensional tolerance standard

# SOG Series

## Oval Concave Suction Cup Special for Cylindrical Objects



Suction Cup

### Features

- ◇ Concave sealing lip structure
- ◇ Internal groove structure

### Advantages

- ◇ Suitable for handling cylindrical workpiece
- ◇ Effectively increase the friction force between suction cup and workpiece surface



### Applications

- ◇ Suitable for cylindrical workpieces, such as steel pipes, plastic round pipes, lithium batteries, etc
- ◇ Handling oily round metal pipes

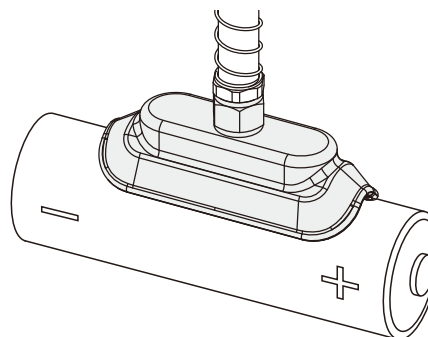

### Structure

- ◇ Concave oval flat structure design

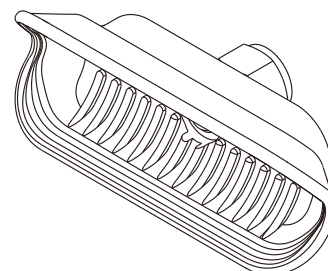

- SZ
- SPH
- SP3
- SUF
- SAN
- SAO
- SOFA
- STP
- SFT
- SFA
- SBT
- SBL
- SBLP
- SBS
- SFP
- SBP
- SXP
- SGP
- SBOF
- STC
- SFF
- SOB
- SOF
- SOG**
- SFM
- SOM
- SBF
- SDM
- SFU
- SFK
- SHT
- SDL
- SFG
- SFGT
- SFD
- SB
- SBA
- SF
- SU
- SP2F
- SPA
- SPD
- SPF
- SPC
- SPJ
- SPU
- SH
- SHB
- SBB
- SOP
- SNP

## Oval Concave Suction Cup Special for Cylindrical Objects

### How to order

**SOG 35×100 N - G2F**  
 ①                      ②                      ③                      ④

① Series	② Size	③ Material & Hardness	④ Connection thread
SOG	15×40	N - NBR <span style="background-color: #d4edda; padding: 2px;">45</span>	M5F - M5×0.8 female thread
	35×100		M5M - M5×0.8 male thread G2F - G1/4 female thread G3F - G3/8 female thread G2M - G1/4 male thread M10M - M10×1.5 male thread M14M - M14×1.5 male thread RA - Rectangular adapter

### Selection

Model	Connection thread M5M	G2M	M10M	M14M
SOG15×40N-□	SOG15×40N-M5M	-	-	-
SOG35×100N-□	-	SOG35×100N-G2M	SOG35×100N-M10M	SOG35×100N-M14M

Model	Connection thread M5F	G2F	G3F	RA
SOG15×40N-□	SOG15×40N-M5F	-	-	-
SOG35×100N-□	-	SOG35×100N-G2F	SOG35×100N-G3F	SOG35×100N-RA

### Technical parameters

Model	Vertical pull-out force N	Inner volume cm <sup>3</sup>	Min.curve radius of workpiece mm	Weight g	Recommended hose dia. mm	MPQ pcs
SOG15×40	22	1.3	8	17	6	5
SOG35×100	122	11	25	23	8	1

◇ Note: Testing vacuum level -60kPa, workpiece with smooth and clean surface. The data of pull-out force as above are figured out without considering safety factor. The data may be different according to different workpiece surfaces.

### Dimensions(mm)

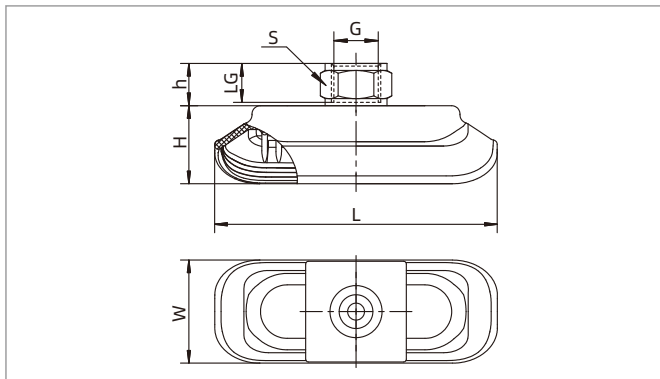

F - Female thread connection

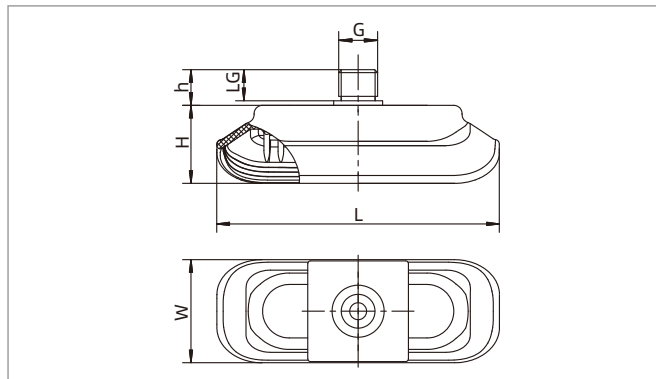

M - Male thread connection

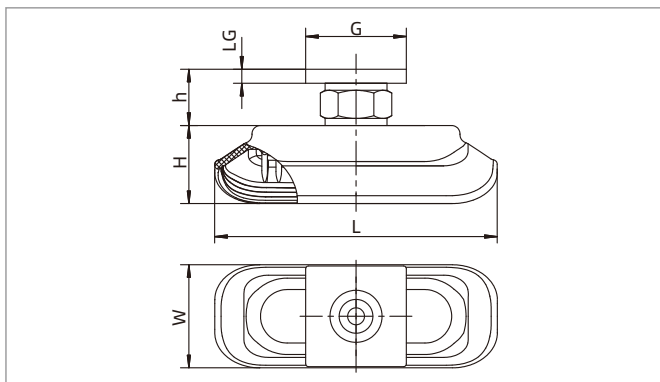

RA - Rectangular adapter

Model/Size	L	W	H	G	LG	h	S
SOG15×40N-M5F	42	15.5	14	M5×0.8	-	-	-
SOG15×40N-M5M	42	15.5	14	M5×0.8	5	6.5	8
SOG35×100N-G2F	100.5	36.5	28	G1/4	11	14	17
SOG35×100N-G3F	100.5	36.5	28	G3/8	11	14	22
SOG35×100N-G2M	100.5	36.5	28	G1/4	9	11	5
SOG35×100N-M10M	100.5	36.5	28	M10×1.5	12	13.5	5
SOG35×100N-M14M	100.5	36.5	28	M14×1.5	12	13.5	5
SOG35×100N-RA	100.5	36.5	28	31.8×31.8	4.7	18.7	-

◇ Note: The dimensional tolerance conforms to GB/T3672.1-2002-1 M3 rubber product dimensional tolerance standard

- SZ
- SPH
- SP3
- SUF
- SAN
- SAO
- SOFA
- STP
- SFT
- SFA
- SBT
- SBL
- SBLP
- SBS
- SFP
- SBP
- SXP
- SGP
- SBOF
- STC
- SFF
- SOB
- SOF
- SOG**
- SFM
- SOM
- SBF
- SDM
- SFU
- SFK
- SHT
- SDL
- SFG
- SFGT
- SFD
- SB
- SBA
- SF
- SU
- SP2F
- SPA
- SPD
- SPF
- SPC
- SPJ
- SPU
- SH
- SHB
- SBB
- SOP
- SNP

# SFM Series

**AIRBEST**

## Flat Suction Cup Special for Oily Metal Sheet



METAL SHEET



SLIPPING RESISTANCE



CURVED SURFACE



OILY SURFACE



LONG LIFETIME



### Features

- ◇ Large compressed stroke, good flexibility
- ◇ PU material
- ◇ Internal large area support structure
- ◇ Various sizes are available

### Advantages

- ◇ Easy to fit workpieces with different shapes of surfaces
- ◇ Long lifetime, and wear resistance, ozone resistance and oil resistance are excellent
- ◇ Effectively enhance friction force between suction cups and workpieces
- ◇ Suitable for workpieces with different sizes and shapes



### Applications

- ◇ Handling of oily metal sheet
- ◇ Handling curved metal sheet
- ◇ Handling automotive stamping metal parts

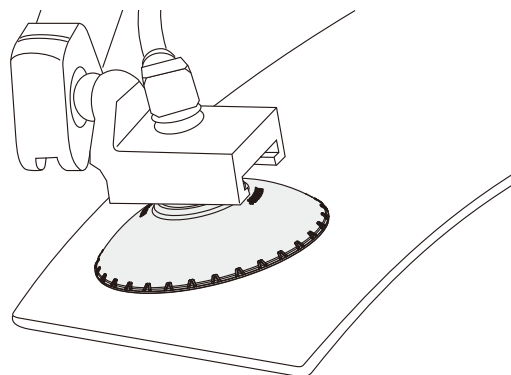

### Structure

- ◇ Split structure design, wearing parts can be replaced separately

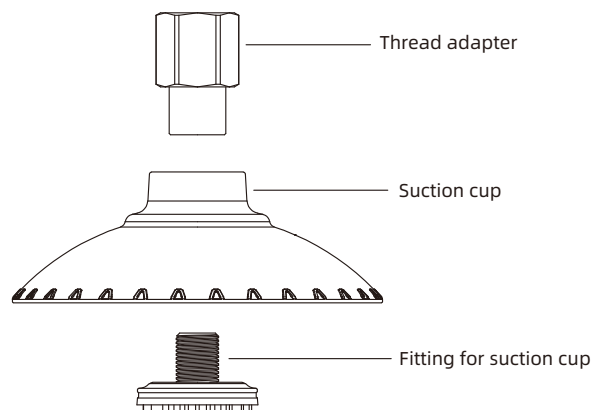

# SFM Series

## Flat Suction Cup Special for Oily Metal Sheet

Suction Cup

### How to order

## SFM 50 U - G3F

① ② ③ ④

① Series	② Diameter	③ Material & Hardness	④ Connection thread
SFM	30 - $\phi$ 30mm	U - PU <span style="background-color: #0070C0; color: white; padding: 0 2px;">70</span>	Nil - Suction cup only
	40 - $\phi$ 40mm		G1F - G1/8 female thread
	50 - $\phi$ 50mm		G2F - G1/4 female thread
	60 - $\phi$ 60mm		G3F - G3/8 female thread
	80 - $\phi$ 80mm		G2M - G1/4 male thread
	100 - $\phi$ 100mm		M10M - M10×1.5 male thread
	120 - $\phi$ 120mm		M14M - M14×1.5 male thread RA - Rectangular adapter

### Selection

Model	Connection thread						
	G2M	M10M	M14M	G1F	G2F	G3F	RA
SFM30U	-	SFM30U-M10M	-	SFM30U-G1F	-	-	SFM30U-RA
SFM40U	-	SFM40U-M10M	-	SFM40U-G1F	-	-	SFM40U-RA
SFM50U	SFM50U-G2M	SFM50U-M10M	SFM50U-M14M	-	SFM50U-G2F	SFM50U-G3F	SFM50U-RA
SFM60U	SFM60U-G2M	SFM60U-M10M	SFM60U-M14M	-	SFM60U-G2F	SFM60U-G3F	SFM60U-RA
SFM80U	SFM80U-G2M	SFM80U-M10M	SFM80U-M14M	-	SFM80U-G2F	SFM80U-G3F	SFM80U-RA
SFM100U	SFM100U-G2M	SFM100U-M10M	SFM100U-M14M	-	SFM100U-G2F	SFM100U-G3F	SFM100U-RA
SFM120U	SFM120U-G2M	SFM120U-M10M	SFM120U-M14M	-	SFM120U-G2F	SFM120U-G3F	SFM120U-RA

### Technical parameters

Model	Pull-out force N	Inner volume cm <sup>3</sup>	Min.curve radius of workpiece mm	Weight g	Recommended hose dia. mm	MPQ pcs
SFM30	45	4.5	25	3.5	6	1
SFM40	70	8.5	30	5.0	6	1
SFM50	112	18.6	35	8.5	8	1
SFM60	150	26	40	11	8	1
SFM80	285	56	60	21	8	1
SFM100	420	105	70	35	10	1
SFM120	580	153	90	55	10	1

◇ Note: Testing vacuum level -60kPa, workpiece with smooth and clean surface. The data of pull-out force as above are figured out without considering safety factor. The data may be different according to different workpiece surfaces.

SZ  
SPH  
SP3  
SUF  
SAN  
SAO  
SOFA  
STP  
SFT  
SFA  
SBT  
SBL  
SBLP  
SBS  
SFP  
SBP  
SXP  
SGP  
SBOF  
STC  
SFF  
SOB  
SOF  
SOG  
SFM  
SOM  
SBF  
SDM  
SFU  
SFK  
SHT  
SDL  
SFG  
SFGT  
SFD  
SB  
SBA  
SF  
SU  
SP2F  
SPA  
SPD  
SPF  
SPC  
SPJ  
SPU  
SH  
SHB  
SBB  
SOP  
SNP

# SFM Series

## Flat Suction Cup Special for Oily Metal Sheet



### Dimensions(mm)

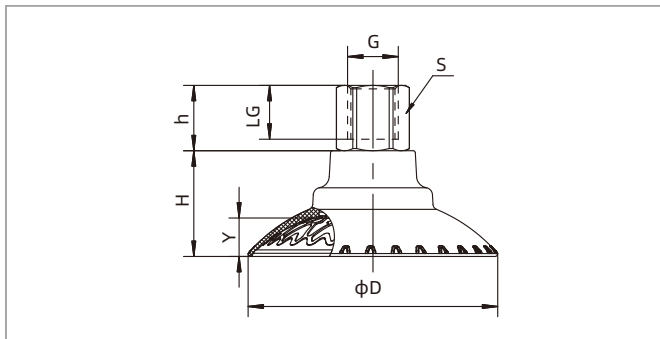

F - Female thread connection

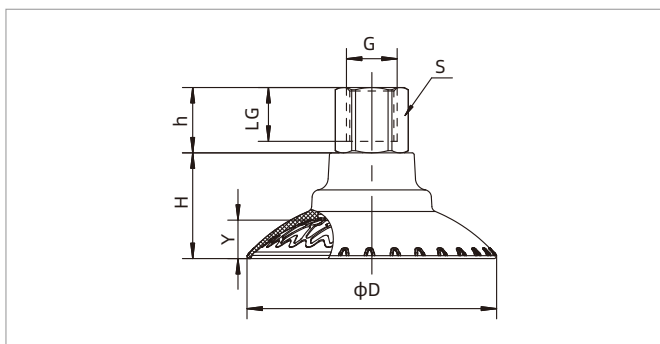

F - Female thread connection

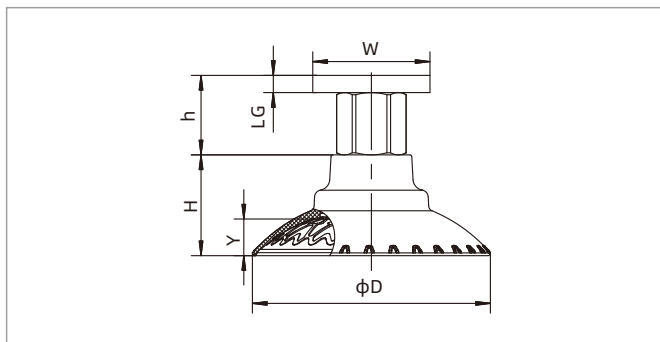

RA - Rectangular adapter

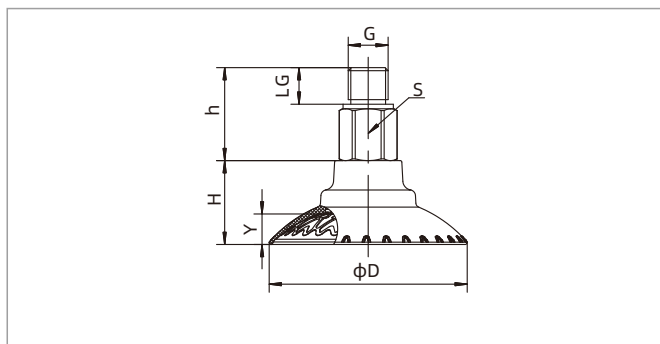

M - Male thread connection

Model/Size	D	H	G	h	LG	S	Y
SFM30U-G1F	34	17.5	G1/8	14	10	14	4
SFM40U-G1F	43.5	20	G1/8	14	10	14	6.3
SFM50U-G2F	55	25	G1/4	17	12	17	7.8
SFM60U-G2F	65	27.5	G1/4	17	12	17	10
SFM80U-G2F	85	30	G1/4	17	12	17	13
SFM100U-G2F	105.5	37	G1/4	17	12	17	15.5
SFM120U-G2F	123	41	G1/4	17	12	17	18.5

Model/Size	D	H	G	h	LG	S	Y
SFM50U-G3F	55	25	G3/8	17	12	22	7.8
SFM60U-G3F	65	27.5	G3/8	17	12	22	10
SFM80U-G3F	85	30	G3/8	17	12	22	13
SFM100U-G3F	105.5	37	G3/8	17	12	22	15.5
SFM120U-G3F	123	41	G3/8	17	12	22	18.5

Model/Size	D	H	w	h	LG	Y
SFM30U-RA	34	17.5	31.8×31.8	21.7	4.7	4
SFM40U-RA	43.5	20	31.8×31.8	21.7	4.7	6.3
SFM50U-RA	55	25	31.8×31.8	21.7	4.7	7.8
SFM60U-RA	65	27.5	31.8×31.8	21.7	4.7	10
SFM80U-RA	85	30	31.8×31.8	21.7	4.7	13
SFM100U-RA	105.5	37	31.8×31.8	21.7	4.7	15.5
SFM120U-RA	123	41	31.8×31.8	21.7	4.7	18.5

Model/Size	D	H	G	h	LG	S	Y
SFM50U-G2M	55	25	G1/4	28	9	17	7.8
SFM60U-G2M	65	27.5	G1/4	28	9	17	10
SFM80U-G2M	85	30	G1/4	28	9	17	13
SFM100U-G2M	105.5	37	G1/4	28	9	17	15.5
SFM120U-G2M	123	41	G1/4	28	9	17	18.5

# SFM Series

## Flat Suction Cup Special for Oily Metal Sheet



### Dimensions(mm)

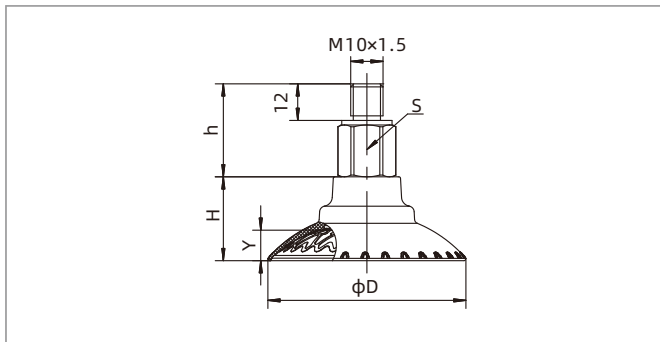

M - Male thread connection

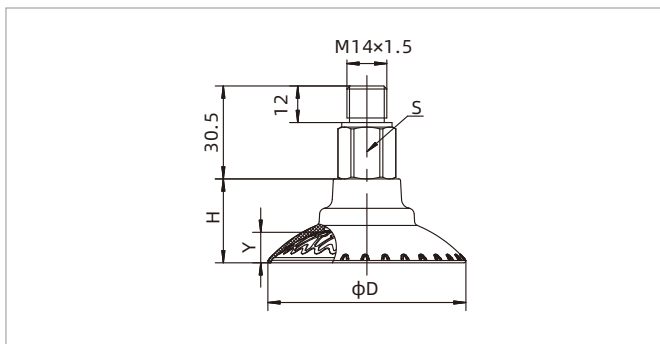

M - Male thread connection

◇ Note: The dimensional tolerance conforms to GBT3672.1-2002-1 M3 rubber product dimensional tolerance standard

Model/Size	D	H	h	S	Y
SFM30U-M10M	34	17.5	27.5	14	4
SFM40U-M10M	43.5	20	27.5	14	6.3
SFM50U-M10M	55	25	30.5	17	7.8
SFM60U-M10M	65	27.5	30.5	17	10
SFM80U-M10M	85	30	30.5	17	13
SFM100U-M10M	105.5	37	30.5	17	15.5
SFM120U-M10M	123	41	30.5	17	18.5

Model/Size	D	H	h	S	Y
SFM50U-M14M	55	25	30.5	17	7.8
SFM60U-M14M	65	27.5	30.5	17	10
SFM80U-M14M	85	30	30.5	17	13
SFM100U-M14M	105.5	37	30.5	17	15.5
SFM120U-M14M	123	41	30.5	17	18.5

### Mounting parts

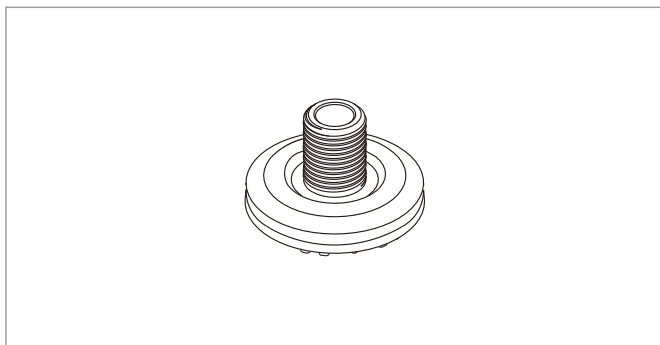

PJS - Fitting for suction cup

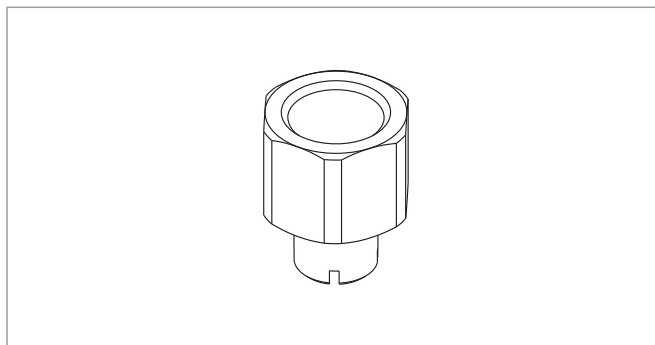

PJT - Thread adapter

Item	Model	Applicable suction cup
Fitting for suction cup	PJS-M8M-SFM40	SFM30,40
	PJS-G1M-SFM80	SFM50,60,80
	PJS-G1M-SFM120	SFM100,120
Thread adapter	PJT-M8F-G1F	SFM30,40
	PJT-G1F-G2F	SFM50,60,80,100,120
	PJT-G1F-G3F	SFM50,60,80,100,120

- SZ
- SPH
- SP3
- SUF
- SAN
- SAO
- SOFA
- STP
- SFT
- SFA
- SBT
- SBL
- SBLP
- SBS
- SFP
- SBP
- SXP
- SGP
- SBOF
- STC
- SFF
- SOB
- SOF
- SOG
- SFM**
- SOM
- SBF
- SDM
- SFU
- SFK
- SHT
- SDL
- SFG
- SFGT
- SFD
- SB
- SBA
- SF
- SU
- SP2F
- SPA
- SPD
- SPF
- SPC
- SPJ
- SPU
- SH
- SHB
- SBB
- SOP
- SNP

# SOM Series

## Oval Flat Suction Cup Special for Long and Narrow Objects

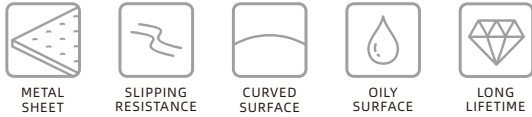

### Features

- ◇ Large stroke and good flexibility
- ◇ PU material
- ◇ Internal large area pattern support structure
- ◇ Non-rotating structure
- ◇ Various sizes are available

### Advantages

- ◇ Easy to fit the workpieces with different shapes of surfaces
- ◇ Long lifetime, excellent wear resistance, ozone resistance, oil resistance
- ◇ Effectively increase friction force between suction cups and workpieces
- ◇ The parts can be recycled
- ◇ The direction of suction cup can be accurately positioned according to workpiece shape
- ◇ Suitable for workpieces with different sizes and shapes



### Applications

- ◇ Handling of oval workpiece with curved surface
- ◇ Handling long and narrow or cylindrical workpieces

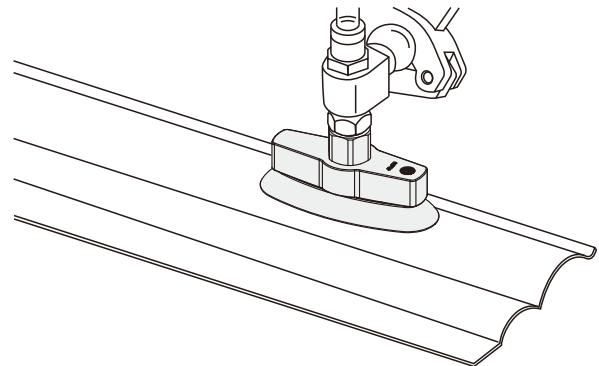

### Structure

- ◇ Split structure design, wearing parts can be replaced separately

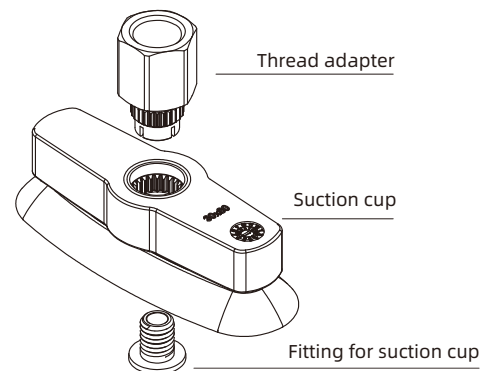

# SOM Series

## Oval Flat Suction Cup Special for Long and Narrow Objects

### How to order

## SOM 30×80 U - G2F

①                      ②                      ③                      ④

① Series	② Size	③ Material & Hardness	④ Connection thread
SOM	20×60	U - PU <span style="background-color: #0070C0; color: white; padding: 2px;">70</span>	Nil - Suction cup only
	30×80		G2F - G1/4 female thread
	40×100		G3F - G3/8 female thread
			G2M - G1/4 male thread
			M10M - M10×1.5 male thread
		M14M - M14×1.5 male thread	
		RA - Rectangular adapter	

### Selection

Model	Connection thread					
	G2M	M10M	M14M	G2F	G3F	RA
SOM20×60U	SOM20×60U-G2M	SOM20×60U-M10M	SOM20×60U-M14M	SOM20×60U-G2F	-	SOM20×60U-RA
SOM30×80U	SOM30×80U-G2M	SOM30×80U-M10M	SOM30×80U-M14M	SOM30×80U-G2F	-	SOM30×80U-RA
SOM40×100U	SOM40×100U-G2M	SOM40×100U-M10M	SOM40×100U-M14M	-	SOM40×100U-G3F	SOM40×100U-RA

### Technical parameters

Model	Vertical pull-out force N	Lateral pull-out force N	Lateral pull-out force (Oily surface)N	Inner volume cm <sup>3</sup>	Min curve radius of workpiece mm	Weight g	Recommended hose dia. mm	MPQ pcs
SOM20×60U	61	44	44	5	10	14	8	1
SOM30×80U	116	110	110	12	20	24.4	8	1
SOM40×100U	187	135	135	25	32	50.6	8	1

◇ Note: Testing vacuum level -60kPa, workpiece with smooth and clean surface. The data of pull-out force as above are figured out without considering safety factor. The data may be different according to different workpiece surfaces.

### Dimensions(mm)

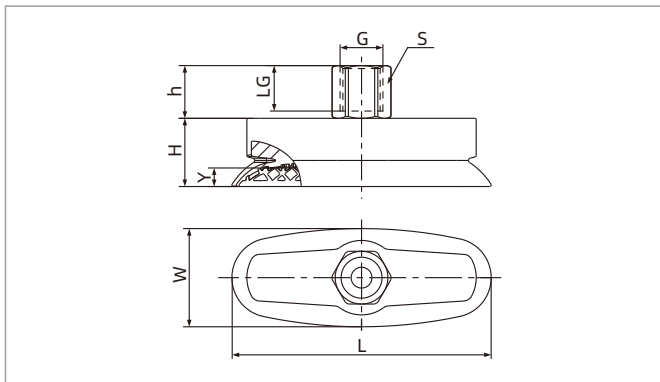

Model/Size	L	W	H	G	h	LG	S	Y
SOM20×60U-G2F	63.5	20.5	22	G1/4	17	12	17	5
SOM30×80U-G2F	83.5	31.5	22	G1/4	17	12	17	6
SOM40×100U-G3F	103.5	43.5	29	G3/8	17	12	22	7

F - Female thread connection

- SZ
- SPH
- SP3
- SUF
- SAN
- SAO
- SOFA
- STP
- SFT
- SFA
- SBT
- SBL
- SBLP
- SBS
- SFP
- SBP
- SXP
- SGP
- SBOF
- STC
- SFF
- SOB
- SOE
- SOG
- SFM
- SOM**
- SBF
- SDM
- SFU
- SFK
- SHT
- SDL
- SFG
- SFGT
- SFD
- SB
- SBA
- SF
- SU
- SP2F
- SPA
- SPD
- SPF
- SPC
- SPJ
- SPU
- SH
- SHB
- SBB
- SOP
- SNP

# SOM Series



## Oval Flat Suction Cup Special for Long and Narrow Objects

### Dimensions(mm)

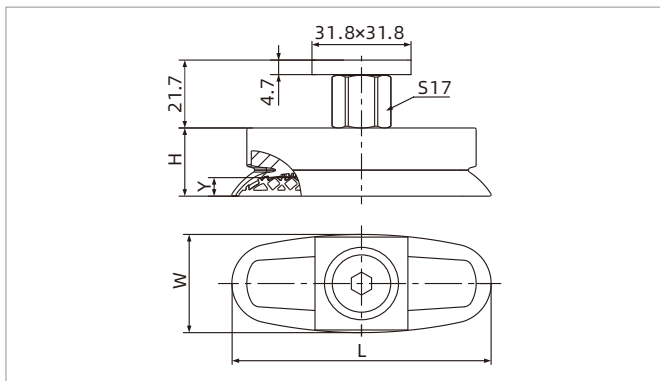

RA - Rectangular adapter

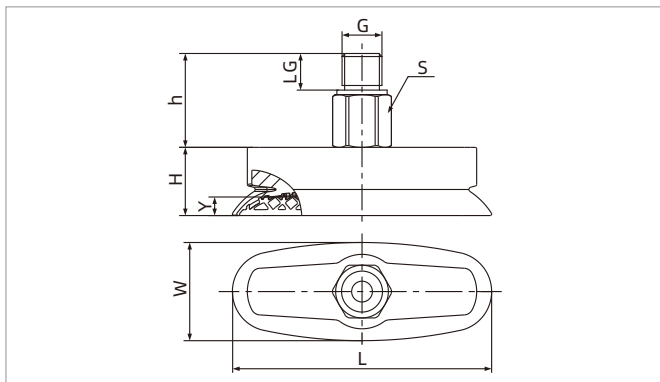

M - Male thread connection

◇ Note: The dimensional tolerance conforms to GBT3672.1-2002-1 M3 rubber product dimensional tolerance standard

Model/Size	L	W	H	Y
SOM20×60U-RA	63.5	20.5	22	5
SOM30×80U-RA	83.5	31.5	22	6
SOM40×100U-RA	103.5	43.5	29	7

Model/Size	L	W	H	G	h	LG	S	Y
SOM20×60U-G2M	63.5	20.5	22	G1/4	28	9	17	5
SOM20×60U-M10M	63.5	20.5	22	M10×1.5	30.5	11	17	5
SOM20×60U-M14M	63.5	20.5	22	M14×1.5	30.5	11	17	5
SOM30×80U-G2M	83.5	31.5	22	G1/4	28	9	17	6
SOM30×80U-M10M	83.5	31.5	22	M10×1.5	30.5	11	17	6
SOM30×80U-M14M	83.5	31.5	22	M14×1.5	30.5	11	17	6
SOM40×100U-G2M	103.5	43.5	29	G1/4	28	9	22	7
SOM40×100U-M10M	103.5	43.5	29	M10×1.5	30.5	11	22	7
SOM40×100U-M14M	103.5	43.5	29	M14×1.5	30.5	11	22	7

# SBF Series

## 1.5 Bellows Suction Cup Special for Metal Sheet



Suction Cup

### Features

- ◇ 1.5 Bellows
- ◇ PU material
- ◇ Internal large area support structure
- ◇ Various sizes for option

### Advantages

- ◇ Easy to fit uneven surface of workpiece, and has buffer effect
- ◇ Excellent wear resistance and oil resistance, long lifetime
- ◇ Effectively increase the friction force between suction cups and workpieces
- ◇ Suitable for workpieces with different sizes and shapes



### Applications

- ◇ Handling metal sheet in high speed, short cycle time
- ◇ Handling metal sheet and aluminum plate without deformation
- ◇ Special pattern slot design of suction cup prevents from slipping during handling oily sheet metal, ensuring accurate positioning
- ◇ Used in automotive stamping metal parts handling system

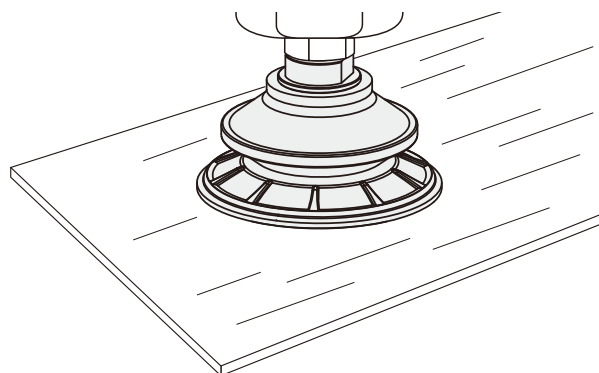

### Structure

- ◇ 1.5 Bellows, large compressed stroke
- ◇ Suction cup and fitting are one-piece structure design

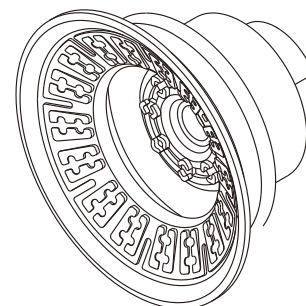

SZ  
SPH  
SP3  
SUF  
SAN  
SAO  
SOFA  
STP  
SFT  
SFA  
SBT  
SBL  
SBLP  
SBS  
SFP  
SBP  
SXP  
SGP  
SBOF  
STC  
SFF  
SOB  
SOF  
SOG  
SFM  
**SOM**  
SBF  
SDM  
SFU  
SFK  
SHT  
SDL  
SFG  
SFGT  
SFD  
SB  
SBA  
SF  
SU  
SP2F  
SPA  
SPD  
SPF  
SPC  
SPJ  
SPU  
SH  
SHB  
SBB  
SOP  
SNP

## 1.5 Bellows Suction Cup Special for Metal Sheet

### How to order

## SBF 50 U - G3F

① ② ③ ④

① Series	② Diameter	③ Material & Hardness	④ Connection thread	
SBF	30 - $\phi$ 32mm	U - PU	70	G2F - G1/4 female thread
	40 - $\phi$ 42mm			G3F - G3/8 female thread
	50 - $\phi$ 51.5mm			G2M - G1/4 male thread
	60 - $\phi$ 64mm			M10M - M10 $\times$ 1.5 male thread
	80 - $\phi$ 84mm			RA - Rectangular adapter
	100 - $\phi$ 103mm			

### Selection - Model(Connection thread)

Model	Connection thread G2M	M10M	G2F	G3F	RA - Rectangular adapter
SBF30U-□	SBF30U-G2M	SBF30U-M10M	SBF30U-G2F	SBF30U-G3F	SBF30U-RA
SBF40U-□	SBF40U-G2M	SBF40U-M10M	SBF40U-G2F	SBF40U-G3F	SBF40U-RA
SBF50U-□	SBF50U-G2M	SBF50U-M10M	SBF50U-G2F	SBF50U-G3F	SBF50U-RA
SBF60U-□	SBF60U-G2M	SBF60U-M10M	SBF60U-G2F	SBF60U-G3F	SBF60U-RA
SBF80U-□	SBF80U-G2M	SBF80U-M10M	SBF80U-G2F	SBF80U-G3F	SBF80U-RA
SBF100U-□	SBF100U-G2M	SBF100U-M10M	SBF100U-G2F	SBF100U-G3F	SBF100U-RA

### Technical parameters

Model	Pull-out force N	Inner volume cm <sup>3</sup>	Min.curve radius of workpiece mm	Weight g	Recommended hose dia. mm	MPQ pcs
SBF30	33	5.5	30	18.5	6	1
SBF40	60	7.0	45	20.0	6	1
SBF50	103	11.5	50	40.0	8	1
SBF60	145	22.0	55	45.0	8	1
SBF80	235	60.0	72	75.0	10	1
SBF100	380	98.0	97	118.0	10	1

◇ Note: Testing vacuum level -60kPa, workpiece with smooth and clean surface. The data of pull-out force as above are figured out without considering safety factor. The data may be different according to different workpiece surfaces.

# SBF Series

## 1.5 Bellows Suction Cup Special for Metal Sheet



### Dimensions(mm)

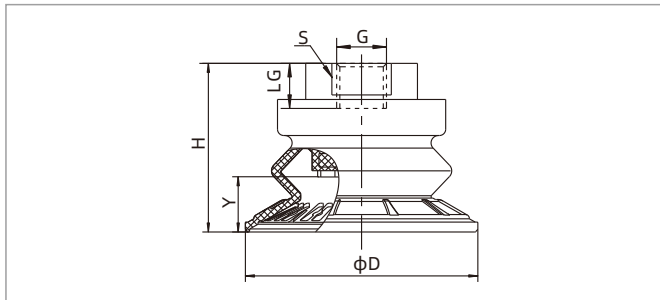

F - Female thread connection

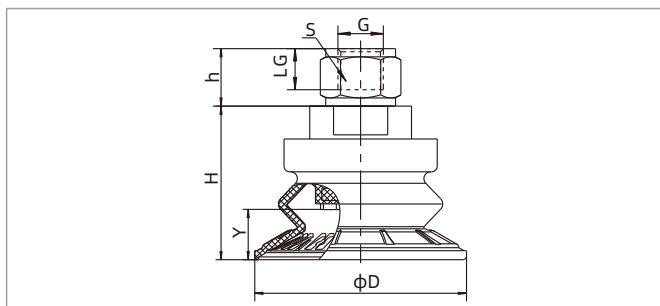

F - Female thread connection

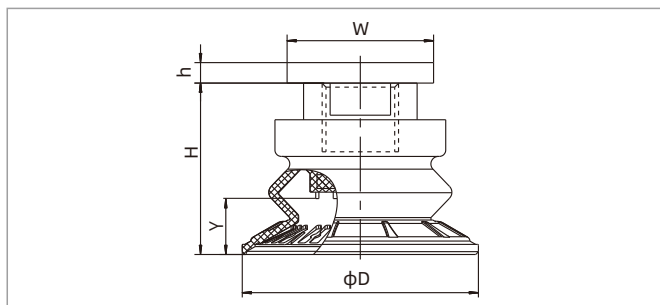

RA - Rectangular adapter

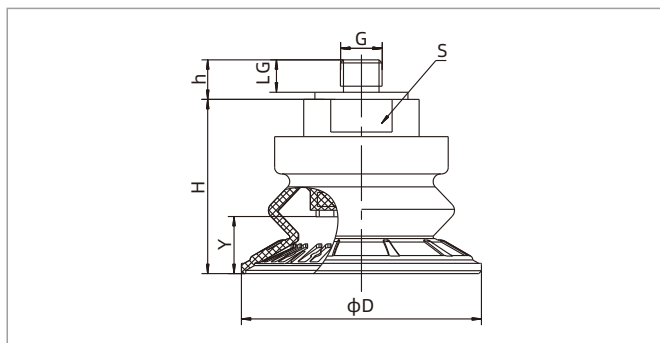

M - Male thread connection

Model/Size	D	H	G	LG	S	Y
SBF30U-G2F	32	28	G1/4	10	17	7
SBF40U-G2F	42	29	G1/4	10	17	9
SBF50U-G3F	51.5	37	G3/8	13	21	12.5
SBF60U-G3F	64	41.5	G3/8	13	21	15
SBF80U-G3F	84	49.5	G3/8	13	21	23
SBF100U-G3F	103	55	G3/8	13	22	22

Model/Size	D	H	G	h	LG	S	Y
SBF30U-G3F	32	28	G3/8	14	11	22	7
SBF40U-G3F	42	29	G3/8	14	11	22	9
SBF50U-G2F	51.5	37	G1/4	14	11	22	12.5
SBF60U-G2F	64	41.5	G1/4	14	11	22	15
SBF80U-G2F	84	49.5	G1/4	14	11	22	23
SBF100U-G2F	103	55	G1/4	14	11	22	22

Model/Size	D	H	W	h	Y
SBF30U-RA	32	28	31.8×31.8	4.7	7
SBF40U-RA	42	29	31.8×31.8	4.7	9
SBF50U-RA	51.5	37	31.8×31.8	4.7	12.5
SBF60U-RA	64	41.5	31.8×31.8	4.7	15
SBF80U-RA	84	49.5	31.8×31.8	4.7	23
SBF100U-RA	103	55	31.8×31.8	4.7	22

Model/Size	D	H	G	h	LG	S	Y
SBF30U-G2M	32	28	G1/4	11	9	17	7
SBF30U-M10M	32	28	M10×1.5	13.5	12	17	7
SBF40U-G2M	42	29	G1/4	11	9	17	9
SBF40U-M10M	42	29	M10×1.5	13.5	12	17	9
SBF50U-G2M	51.5	37	G1/4	11	9	21	12.5
SBF50U-M10M	51.5	37	M10×1.5	13.5	12	21	12.5
SBF60U-G2M	64	41.5	G1/4	11	9	21	15
SBF60U-M10M	64	41.5	M10×1.5	13.5	12	21	15
SBF80U-G2M	84	49.5	G1/4	11	9	21	23
SBF80U-M10M	84	49.5	M10×1.5	13.5	12	21	23
SBF100U-G2M	103	55	G1/4	11	9	22	22
SBF100U-M10M	103	55	M10×1.5	13.5	12	22	22

◇ Note: The dimensional tolerance conforms to GBT3672.1-2002-1 M3 rubber product dimensional tolerance standard

- SZ
- SPH
- SP3
- SUF
- SAN
- SAO
- SOFA
- STP
- SFT
- SFA
- SBT
- SBL
- SBLP
- SBS
- SFP
- SBP
- SXP
- SGP
- SBOF
- STC
- SFF
- SOB
- SOF
- SOG
- SFM
- SOM
- SBF**
- SDM
- SFU
- SFK
- SHT
- SDL
- SFG
- SFGT
- SFD
- SB
- SBA
- SF
- SU
- SP2F
- SPA
- SPD
- SPF
- SPC
- SPJ
- SPU
- SH
- SHB
- SBB
- SOP
- SNP

# SDM Series

## Flat Suction Cup Special for Metal Sheet



### Features

- ◇ PU material
- ◇ Thicken the wall thickness, internal reinforced rib structure design

### Advantages

- ◇ Long lifetime, excellent wear resistance, ozone resistance, oil resistance
- ◇ Effectively prevent deformation of metal sheet during handling



### Applications

- ◇ Handling metal sheet and aluminum plate without deformation

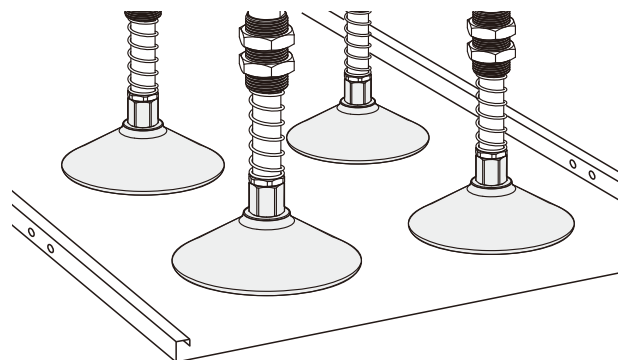

### Structure

- ◇ Split structure design, wearing parts can be replaced separately

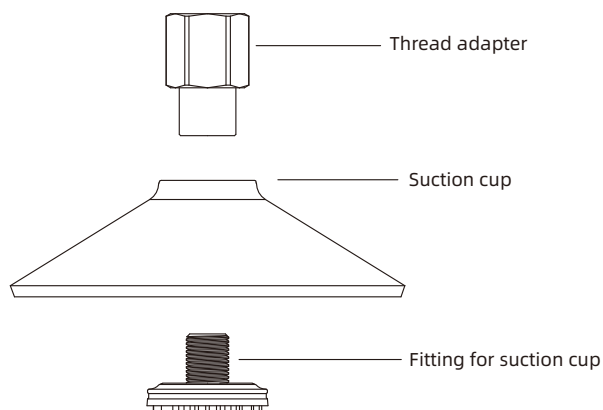

# SDM Series

## Flat Suction Cup Special for Metal Sheet

### How to order

## SDM 100 U - G3F

①      ②      ③      ④

① Series	② Diameter	③ Material & Hardness	④ Connection thread
SDM	100 - $\phi$ 100mm	U - PU <span style="background-color: #0070C0; color: white; padding: 2px;">70</span>	Nil - Suction cup only G2F - G1/4 female thread G3F - G3/8 female thread

### Selection

Model	Connection thread G2F	G3F
SDM100U	SDM100U-G2F	SDM100U-G3F

### Technical parameters

Model	Pull-out force N	Inner volume cm <sup>3</sup>	Min.curve radius of workpiece mm	Weight g	Recommended hose dia. mm	MPQ pcs
SDM100	375	56	160	62	8	1

◇ Note: Testing vacuum level -60kPa, workpiece with smooth and clean surface. The data of pull-out force as above are figured out without considering safety factor. The data may be different according to different workpiece surfaces.

### Dimensions(mm)

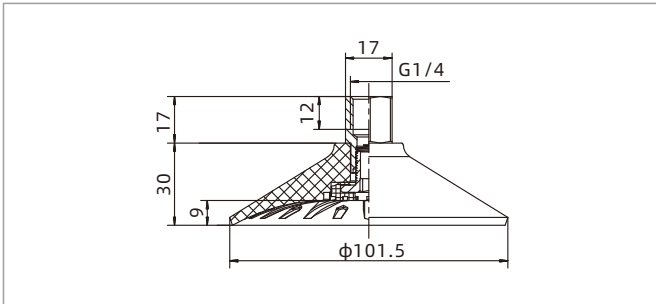

SDM100U-G2F

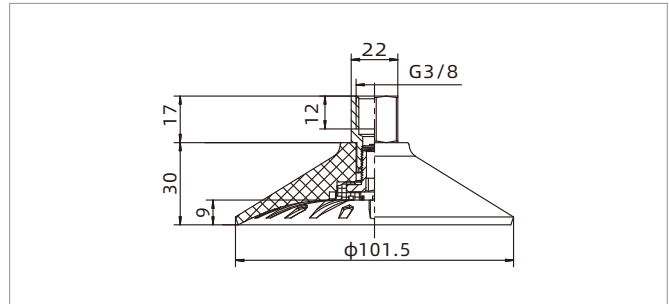

SDM100U-G3F

◇ Note: The dimensional tolerance conforms to GB/T3672.1-2002-1 M3 rubber product dimensional tolerance standard

### Mounting parts

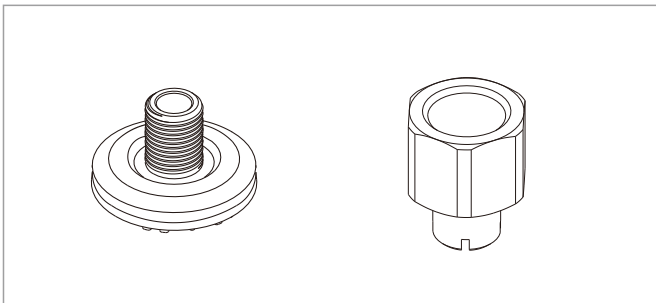

PJS - Fitting for suction cup

PJT - Thread adapter

Item	Model	Applicable suction cup
Fitting for suction cup	PJS-G1M-SFM80	SDM100
Thread adapter	PJT-G1F-G2F	SDM100
	PJT-G1F-G3F	SDM100

# SFU Series

## Big Flat Suction Cup

AIRBEST



METAL SHEET



WOOD



HEAVY LOAD



### Features

- ◇ Large area support structure at bottom
- ◇ Double sealing lip
- ◇ Small inner volume
- ◇ Rubber parts can be replaced separately
- ◇ Various sizes are available

### Advantages

- ◇ Prevent thin workpieces from permanent deformation
- ◇ Excellent airtightness, large suction force
- ◇ Short work cycle
- ◇ Reduce customer's cost greatly
- ◇ Suitable for workpieces with different sizes and shapes



### Applications

- ◇ Handling workpieces with flat or slightly deformed surfaces
- ◇ Touch valve is optional, which closes relevant vacuum circuit when it detects that there is no contact with workpiece

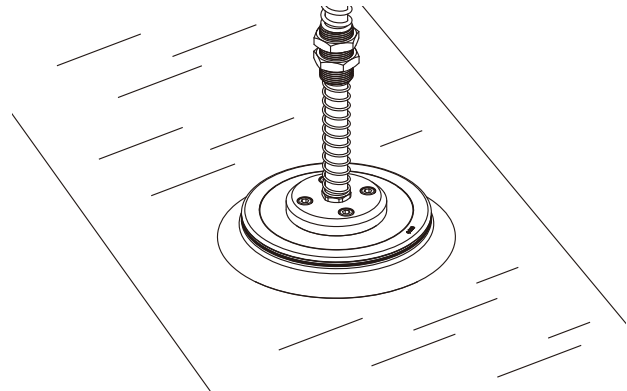

### Structure

- ◇ Fitting for suction cup and rubber parts are split structure design, wearing parts can be replaced separately
- ◇ Separate functional port is available
- ◇ Touch valve is optional, preventing accidental vacuum leakage
- ◇ Note: The functional threaded hole is sealed with a plug when delivered. Seal the thread with thread glue or raw tape when connecting

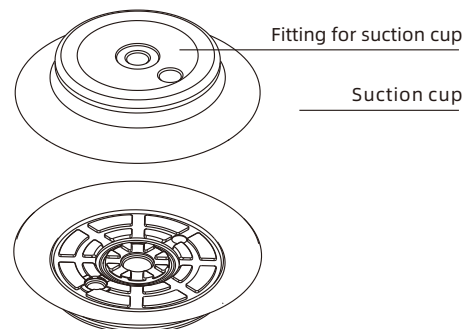

# SFU Series

## Big Flat Suction Cup

### How to order

**SFU 210 H N - G4F - V**  
 ①      ②      ③      ④      ⑤      ⑥

① Series	② Diameter	③ Stroke	④ Material & Hardness	⑤ Connection thread	⑥ Special specification
SFU	100 - φ100mm	Nil - Standard stroke	N - NBR	55 G2F - G1/4 female thread	Nil - Standard
	125 - φ125mm	H - High stroke	WS - White silicone	60 G4F - G1/2 female thread	V - With touch valve
	160 - φ160mm				
	210 - φ210mm				
	250 - φ250mm				
	300 - φ300mm				
	360 - φ360mm				
	400 - φ400mm				

### Selection

Model	Connection thread	Special specification
SFU100□	SFU100□-G2F	-
SFU125□	SFU125□-G2F	SFU125□-G2F-V
SFU160□	SFU160□-G4F	SFU160□-G4F-V
SFU210□    SFU210H□	SFU210□-G4F    SFU210H□-G4F	SFU210□-G4F-V
SFU250□    SFU250H□	SFU250□-G4F    SFU250H□-G4F	SFU250□-G4F-V
SFU300□	SFU300□-G4F	-
-            SFU360H□	-            SFU360H□-G4F	-
SFU400□	SFU400□-G4F	-

### Technical parameters

Model	Pull-out force N	Inner volume cm <sup>3</sup>	Min.curve radius of workpiece mm	Weight g	Recommended hose dia. mm	MPQ pcs
SFU100□-G2F	400	45	175	108	12	1
SFU125□-G2F	670	78	275	215	12	1
SFU160□-G4F	1,100	145	475	397	16	1
SFU210□-G4F	1,900	190	1,050	861	16	1
SFU210H□-G4F	1,900	300	550	885	16	1
SFU250□-G4F	2,600	370	1,100	1,230	16	1
SFU250H□-G4F	2,600	500	750	1,332	16	1
SFU300□-G4F	4,000	490	1,800	1,996	16	1
SFU360H□-G4F	5,800	1,250	1,500	3,696	16	1
SFU400□-G4F	7,000	860	3,300	4,720	16	1

◇ Note: Testing vacuum level -60kPa, workpiece with smooth and clean surface. The data of pull-out force as above are figured out without considering safety factor. The data may be different according to different workpiece surfaces. Recommend the length of vacuum hose to be as short as possible, max 2m.

- SZ
- SPH
- SP3
- SUF
- SAN
- SAO
- SOFA
- STP
- SFT
- SFA
- SBT
- SBL
- SBLP
- SBS
- SFP
- SBP
- SXP
- SGP
- SBOF
- STC
- SFF
- SOB
- SOE
- SOG
- SFM
- SOM
- SBF
- SDM
- SFU**
- SFK
- SHT
- SDL
- SFG
- SFGT
- SFD
- SB
- SBA
- SF
- SU
- SP2F
- SPA
- SPD
- SPF
- SPC
- SPJ
- SPU
- SH
- SHB
- SBB
- SOP
- SNP

# SFU Series

## Big Flat Suction Cup

### Dimensions(mm)

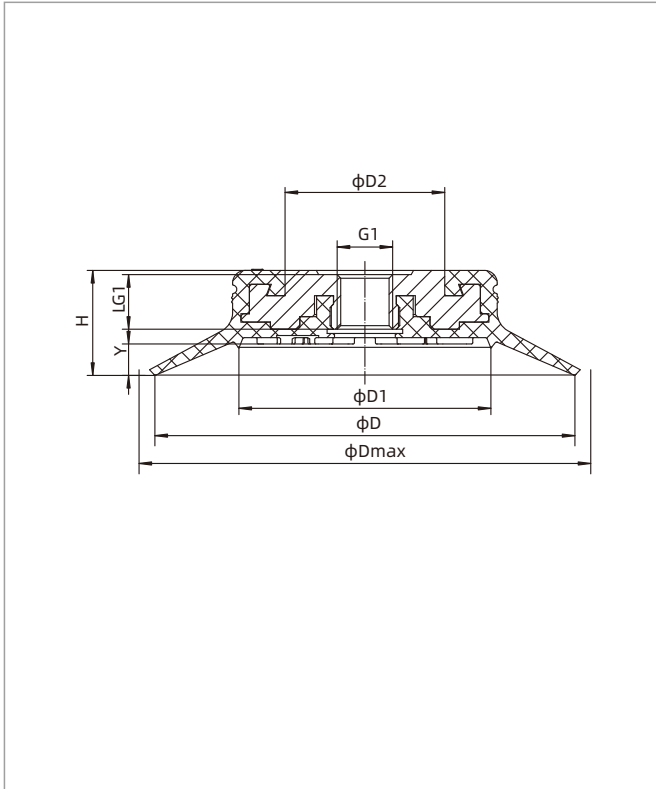

SFU100

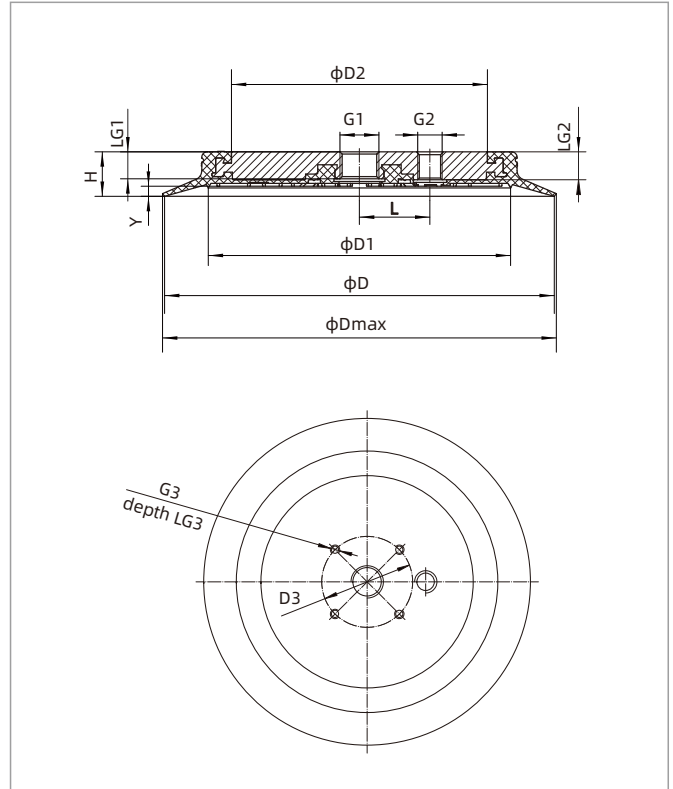

SFU125-400

Model/Size	D	Dmax	D1	D2	D3	H	G1	G2	LG1	LG2	G3	LG3	L	Y
SFU100□-G2F	100	108	60	38	-	25	G1/4	-	13	-	-	-	-	7
SFU125□-G2F	125	132	83	64	-	25	G1/4	G1/4	13	14	-	-	24	7
SFU160□-G4F	160	170	113	91	-	25	G1/2	G1/4	13	15	-	-	38	7
SFU210□-G4F	210	220	163	138	59	25	G1/2	G1/4	14.5	15	M6	8	38	5
SFU210H□-G4F	210	220	159	138	59	30	G1/2	G1/4	14.5	15	M6	8	38	10
SFU250□-G4F	250	265	203	178	59	26	G1/2	G1/2	14.5	15	M6	8	76	7
SFU250H□-G4F	250	265	203	178	59	30	G1/2	G1/2	14.5	15	M6	8	76	11
SFU300□-G4F	300	320	253	226.5	59	25.5	G1/2	G1/2	14.5	15	M8	10	76	6
SFU360H□-G4F	360	385	309	275	59	35	G1/2	G1/2	17	17	M8	10	86	12
SFU400□-G4F	400	430	349	315	59	29	G1/2	G1/2	17	17	M8	10	86	6

◇ Note: 1. The dimensional tolerance conforms to GBT3672.1-2002-1 M3 rubber product dimensional tolerance standard.  
 2. Dmax is outer diameter of the suction cup when it is completely compressed

# SFU Series

## Big Flat Suction Cup

### Dimensions(mm)

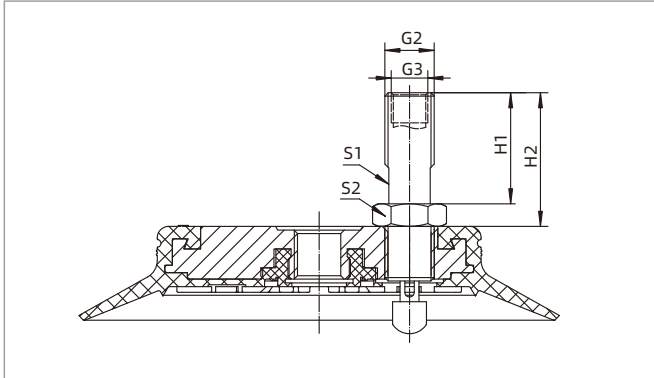

SFU125

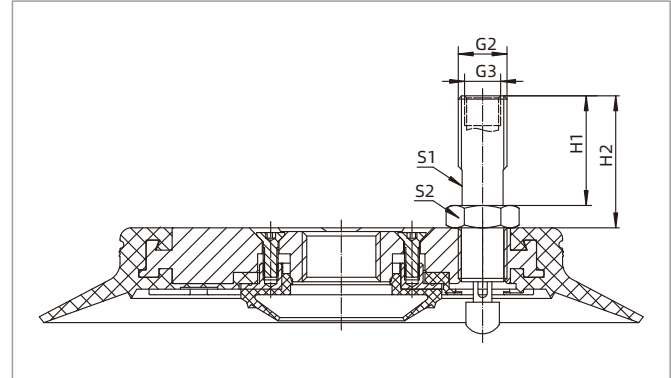

SFU160-250

Model/Size	G2	G3	H1	H2	S1	S2
SFU125□-G2F-V	G1/4	G1/8	30	36	11	17
SFU160□-G4F-V	G1/4	G1/8	30	36	11	17
SFU210□-G4F-V	G1/4	G1/8	30	36	11	17
SFU250□-G4F-V	G1/2	G3/8	31.5	39.5	19	27

### Mounting parts

Item	Model	Applicable suction cup
Touch valve	ZVD-G2M	SFU125,160,210
	ZVD-G4M	SFU250

Item	Model	Applicable suction cup
Rubber parts for suction cup	SFU100N SFU100WS	SFU100□-G2F
	SFU125N SFU125WS	SFU125□-G2F
	SFU160N SFU160WS	SFU160□-G4F
	SFU210N SFU210WS	SFU210□-G4F
	SFU210HN SFU210HWS	SFU210H□-G4F
	SFU250N SFU250WS	SFU250□-G4F
	SFU250HN SFU250HWS	SFU250H□-G4F
	SFU300N SFU300WS	SFU300□-G4F
	SFU360HN SFU360HWS	SFU360H□-G4F
	SFU400N SFU400WS	SFU400□-G4F

◇ Note: When you buy rubber parts only, pls ensure that the fitting for suction cup you buy is in good condition, and send it back to factory to replace the rubber parts

- SZ
- SPH
- SP3
- SUF
- SAN
- SAO
- SOFA
- STP
- SFT
- SFA
- SBT
- SBL
- SBLP
- SBS
- SFP
- SBP
- SXP
- SGP
- SBOF
- STC
- SFF
- SOB
- SOF
- SOG
- SFM
- SOM
- SBF
- SDM
- SFU**
- SFK
- SHT
- SDL
- SFG
- SFGT
- SFD
- SB
- SBA
- SF
- SU
- SP2F
- SPA
- SPD
- SPF
- SPC
- SPJ
- SPU
- SH
- SHB
- SBB
- SOP
- SNP

# SFK Series

## Flat Suction Cup Special for Objects with Rough Surface



### Features

- ◇ Sealing ring is made of flexible EPDM foam rubber
- ◇ Internal large area support structure
- ◇ Small inner volume
- ◇ Various sizes are available

### Advantages

- ◇ Suitable for workpieces with rough or uneven surfaces
- ◇ Slipping resistance. Prevent thin workpiece from permanent deformation
- ◇ Short work cycle
- ◇ Suitable for workpieces with different sizes and shapes



### Applications

- ◇ Handling workpieces with uneven surfaces, such as embossed steel plate, decorative glass, rough slate, wooden plate, etc.
- ◇ Touch valve is optional, which will close vacuum chamber when it detects that suction cups do not contact workpieces, in order to avoid vacuum leakage

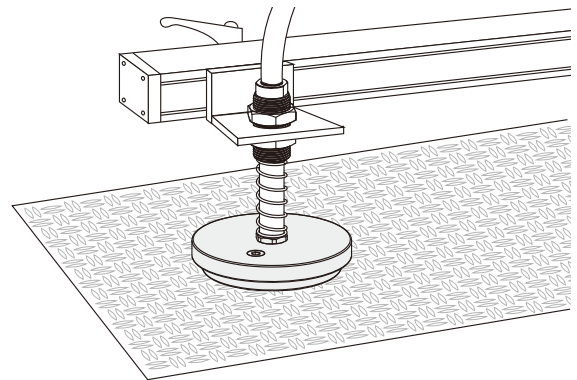

### Structure

- ◇ Split structure design, wearing parts can be replaced separately
- ◇ Separate functional port is equipped

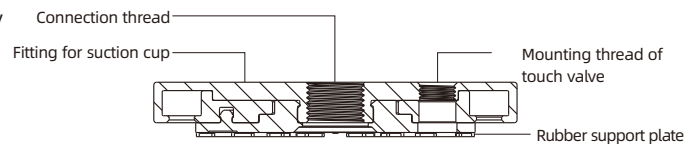

- ◇ Note: The functional threaded hole is sealed with a plug when delivered. Seal the thread with thread glue or raw tape when connecting

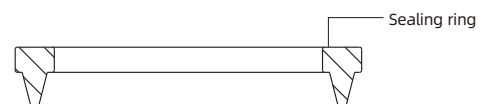

# SFK Series

Flat Suction Cup Special for Objects with Rough Surface

## How to order

**SFK 110 E - G4F - V**  
 ①            ②            ③            ④            ⑤

① Series	② Diameter	③ Material & Hardness	④ Connection thread	⑤ Special specification
SFK	110 - $\phi$ 110mm	E - EPDM	20 Nil - Sealing ring only G4F - G1/2 female thread	Nil - Standard V - With touch valve
	160 - $\phi$ 160mm			
	200 - $\phi$ 200mm			
	250 - $\phi$ 250mm			

## Selection

Model	Connection thread F - Female thread	
SFK110E	SFK110E-G4F	SFK110E-G4F-V
SFK160E	SFK160E-G4F	SFK160E-G4F-V
SFK200E	SFK200E-G4F	SFK200E-G4F-V
SFK250E	SFK250E-G4F	SFK250E-G4F-V

## Technical parameters

Model	Pull-out force N	Inner volume cm <sup>3</sup>	Min.curve radius of workpiece mm	Weight g	Recommended hose dia. mm	MPQ pcs
SFK110	480	70	300	465	10	1
SFK160	1080	145	600	935	10	1
SFK200	1800	225	1000	1445	12	1
SFK250	2800	360	1500	2225	12	1

◇ Note: Testing vacuum level -60kPa, workpiece with smooth and clean surface. The data of pull-out force as above are figured out without considering safety factor. The data may be different according to different workpiece surfaces. Recommend the length of vacuum hose to be as short as possible, max 2m.

## Dimensions(mm)

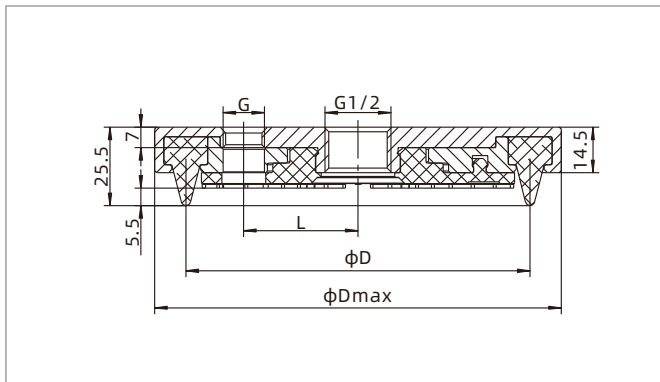

Model/Size	Dmax	D	G	L
SFK110E-G4F	130	110	G1/4	36.5
SFK160E-G4F	179	160	G1/4	36.5
SFK200E-G4F	219	200	G1/2	76
SFK250E-G4F	269	250	G1/2	76

SFK110-250

- SZ
- SPH
- SP3
- SUF
- SAN
- SAO
- SOFA
- STP
- SFT
- SFA
- SBT
- SBL
- SBLP
- SBS
- SFP
- SBP
- SXP
- SGP
- SBOF
- STC
- SFF
- SOB
- SOF
- SOG
- SFM
- SOM
- SBF
- SDM
- SFU
- SFK**
- SHT
- SDL
- SFG
- SFGT
- SFD
- SB
- SBA
- SF
- SU
- SP2F
- SPA
- SPD
- SPF
- SPC
- SPJ
- SPU
- SH
- SHB
- SBB
- SOP
- SNP

# SFK Series



## Flat Suction Cup Special for Objects with Rough Surface

### Dimensions(mm)

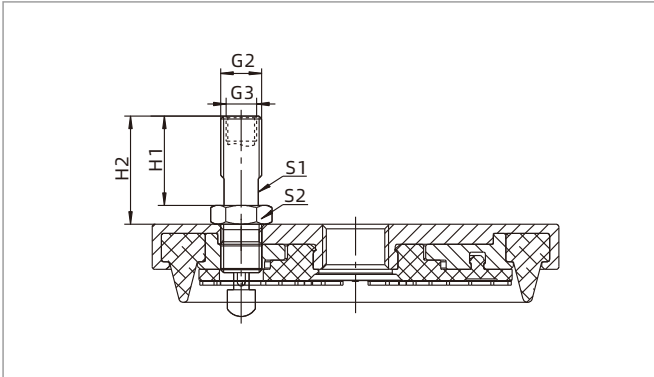

SFK110-250

Model/Size	G2	G3	H1	H2	S1	S2
SFK110E-G4F-V	G1/4	G1/8	27.5	33.5	11	17
SFK160E-G4F-V	G1/4	G1/8	27.5	33.5	11	17
SFK200E-G4F-V	G1/2	G3/8	29.5	37.5	19	27
SFK250E-G4F-V	G1/2	G3/8	29.5	37.5	19	27

- ◇ Note: 1. The dimensional tolerance conforms to GB/T3672.1-2002-1 M3 rubber product dimensional tolerance standard  
 2. The height of the touch valve contact beyond the suction cup lip can be adjusted by itself according to the actual application. Locking the nut after height position is determined. Applicable thread sealant should be applied to the thread connection of touch valve and fitting for suction cup

### Accessories

Item	Model	Applicable suction cup
Touch valve	ZVD-G2M	SFK110,160
	ZVD-G4M	SFK200,250

# SHT Series

## High Temperature Suction Cup



### Features

- ◇ The body is made of stainless steel
- ◇ The sealing ring is made of special high temperature resistant textile material
- ◇ Long time high temperature resistance up to 600°C

### Advantages

- ◇ Strong wear resistance
- ◇ Excellent high temperature resistance, can achieve long time contact with the workpiece



### Applications

- ◇ Handling workpieces with smooth and flat surfaces
- ◇ Hot forming of metal workpieces and other processes
- ◇ For float glass and tempering processes
- ◇ Note: All components in the matching vacuum circuit should be made of high temperature resistant materials

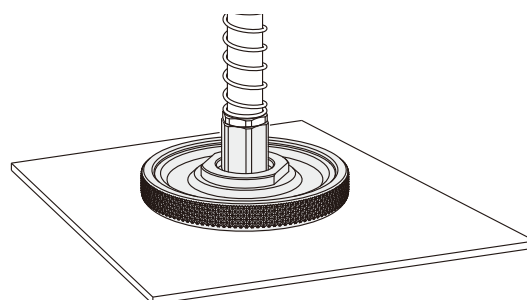

### Structure

- ◇ Split structure design, wearing parts can be replaced separately

### How to order

**SHT 35 - G1F**  
 ①      ②      ③

① Series	② Diameter	③ Connection thread
SHT	35 - $\phi$ 35mm 60 - $\phi$ 60mm 90 - $\phi$ 90mm	Nil - Sealing parts only G1F - G1/8 female thread G2F - G1/4 female thread

### Selection

Model	Connection thread G1F	G2F
SHT35-□	SHT35-G1F	-
SHT60-□	-	SHT60-G2F
SHT90-□	-	SHT90-G2F

- SZ
- SPH
- SP3
- SUF
- SAN
- SAO
- SOFA
- STP
- SFT
- SFA
- SBT
- SBL
- SBLP
- SBS
- SFP
- SBP
- SXP
- SGP
- SBOF
- STC
- SFF
- SOB
- SOE
- SOG
- SFM
- SOM
- SBF
- SDM
- SFU
- SFK
- SHT**
- SDL
- SFG
- SFGT
- SFD
- SB
- SBA
- SF
- SU
- SP2F
- SPA
- SPD
- SPF
- SPC
- SPJ
- SPU
- SH
- SHB
- SBB
- SOP
- SNP

# SHT Series

## High Temperature Suction Cup

### Technical parameters

Model	Pull-out force N	Inner volume cm <sup>3</sup>	Vacuum flow (NL/min) (Vacuum level-70kPa)	Weight g	Recommended hose dia. mm	MPQ pcs
SHT35-G1F	60	4	20	195	6	1
SHT60-G2F	130	10	22	408	8	1
SHT90-G2F	280	30	24	655	8	1

◇ Note: Testing vacuum level -60kPa, workpiece with smooth and clean surface. The data of pull-out force as above are figured out without considering safety factor. The data may be different according to different workpiece surfaces.

### Dimensions(mm)

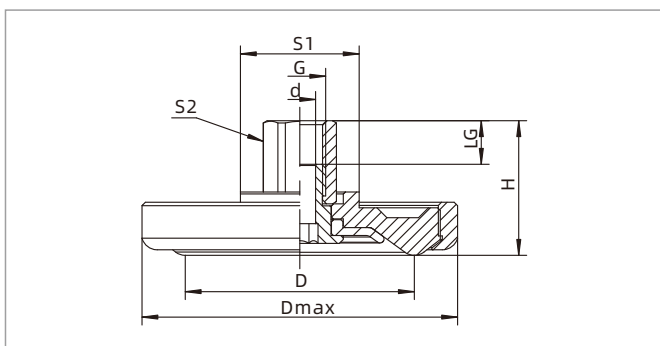

SHT

Model/Size	D	H	G	LG	Dmax	d	S1	S2
SHT35-G1F	35	28	G1/8	9	53	6	30	14
SHT60-G2F	58	34	G1/4	11	80	8	30	17
SHT90-G2F	90	33	G1/4	11	112	8	46	17

# SDL Series

## Annular Suction Cup



METAL SHEET



### Features

- ◇ Closed annular structure, consisting of inner and outer sealing lips
- ◇ Larger area hollow part inside
- ◇ Circular threaded mounting holes

### Advantages

- ◇ Good sealing
- ◇ Detection instrument can be designed in the hollow part for separation of vacuum and detection
- ◇ Firm installation



### Applications

- ◇ Handling of workpieces with flat surface, such as metal sheet, steel plate, annular metal stamping parts, plywood and plastic plate

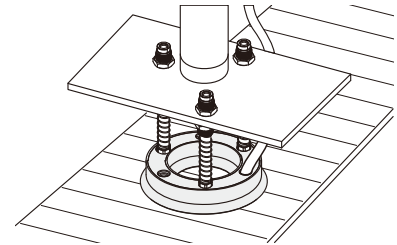

### Structure

- ◇ One-piece structure of fitting and suction cup

### How to order

SDL 100 N - G1F  
① ② ③ ④

① Series	② Diameter	③ Material & Hardness	④ Connection thread
SDL	100 - $\phi$ 100mm	N - NBR <b>55</b>	G1F - G1/8 female thread

### Technical parameters

Model	Pull-out force N	Inner volume cm <sup>3</sup>	Weight g	Recommended hose dia. mm	MPQ pcs
SDL100N-G1F	258	44	107	8	1

◇ Note: Testing vacuum level -60kPa, workpiece with smooth and clean surface. The data of pull-out force as above are figured out without considering safety factor. The data may be different according to different workpiece surfaces. Recommend the length of vacuum hose to be as short as possible, max 2m.

### Dimensions(mm)

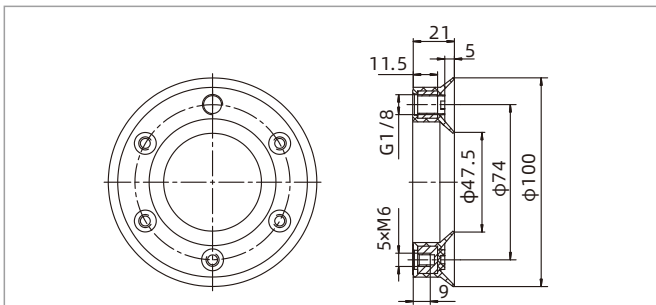

SDL100

◇ Note: The dimensional tolerance conforms to GB/T3672.1-2002-1 M3 rubber product dimensional tolerance standard

# SFG Series

## Flat Suction Cup Special for Glass Industry

AIRBEST



GLASS



SLIPPING  
RESISTANCE



HIGH SEALING



### Features

- ◇ Double flat sealing lips
- ◇ Inner large area pattern support structure at the bottom
- ◇ Small inner volume, two compressed stroke
- ◇ Some specifications are split structure
- ◇ Various sizes are available

### Advantages

- ◇ Excellent airtightness
- ◇ Large friction coefficients, prevent deformation of workpiece
- ◇ Short work cycle, with high stroke, it can suck glass with a certain curvature
- ◇ Metal parts can be used repeatedly, reducing customer's cost greatly
- ◇ Suitable for workpieces with different sizes and shapes

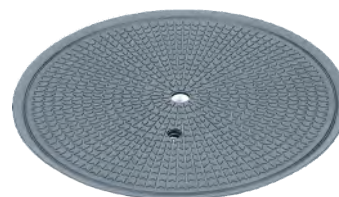

### Applications

- ◇ Handling workpieces with smooth surface such as glass, plastic plate, ect. Realizing long time pressure holding
- ◇ Handling big workpieces with a certain curvature on surface, such as car windshields
- ◇ Handling thin workpieces, such as flat glass or coated glass
- ◇ Handling glass plate surfaced with separation powder or stripping powder

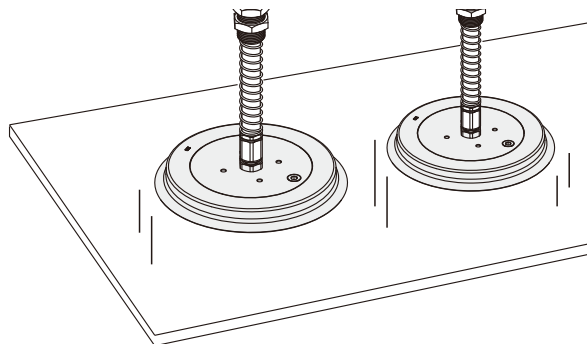

### Structure

- ◇ Double sealing lip, special pattern structure
- ◇ For SFG200 and diameter less than 200mm, they are split structure, wearing parts can be replaced separately. For diameter more than 200mm, they are one-piece structure
- ◇ With large area aluminum fitting for suction cup, it can effectively prevent light and thin workpiece from bending when handling heavy load workpieces
- ◇ Standard stroke and high stroke are optional, with high stroke, it can suck glass with a certain curvature
- ◇ With separate functional port
- ◇ Note: The functional threaded hole is sealed with a plug when delivered. Seal the thread with thread glue or raw tape when connecting

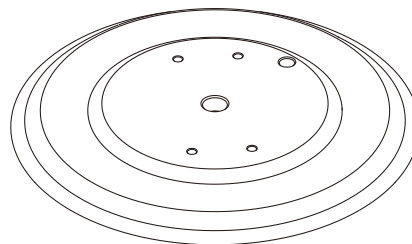

# SFG Series

Flat Suction Cup Special for Glass Industry

## How to order

### SFG 150 H E - G4F

①      ②      ③      ④      ⑤

① Series	② Diameter	③ Stroke	④ Material & Hardness	⑤ Connection thread
SFG	125 - φ125mm	Nil - Standard stroke	E - EPDM	55 G2F - G1/4 female thread
	150 - φ150mm	H - High stroke	HD - High temp/ Mark free material	60 G3F - G3/8 female thread
	200 - φ200mm			G4F - G1/2 female thread
	250 - φ250mm			
	300 - φ300mm			
	350 - φ350mm			
	400 - φ400mm			

## Selection

Model/ Stroke	H - High stroke
SFG125□-G2F    SFG125□-G3F	-
SFG150□-G4F	SFG150H□-G4F
SFG200□-G4F	-
-	SFG250H□-G4F
-	SFG300H□-G4F
-	SFG350H□-G4F
SFG400□-G4F	-

## Technical parameters

Model	Pull-out force N	Inner volume cm <sup>3</sup>	Min.curve radius of workpiece mm	Weight g	Recommended hose dia. mm	MPQ pcs
SFG125	740	44	1,500	290	8	1
SFG150	1,100	65	2,000	490	8	1
SFG150H	1,100	119	370	490	8	1
SFG200	1,950	144	3,500	1,040	10	1
SFG250H	2,950	372	1,600	950	10	1
SFG300H	4,300	550	2,400	1,510	12	1
SFG350H	5,780	779	3,000	2,040	12	1
SFG400	7,600	560	13,500	2,635	12	1

◇ Note: Testing vacuum level -60kPa, workpiece with smooth and clean surface. The data of pull-out force as above are figured out without considering safety factor. The data may be different according to different workpiece surfaces. Recommend the length of vacuum hose to be as short as possible, max 2m.

- SZ
- SPH
- SP3
- SUF
- SAN
- SAO
- SOFA
- STP
- SFT
- SFA
- SBT
- SBL
- SBLP
- SBS
- SFP
- SBP
- SXP
- SGP
- SBOF
- STC
- SFF
- SOB
- SOE
- SOG
- SFM
- SOM
- SBF
- SDM
- SFU
- SFK
- SHT
- SDL
- SFG
- SFGT
- SFD
- SB
- SBA
- SF
- SU
- SP2F
- SPA
- SPD
- SPF
- SPC
- SPJ
- SPU
- SH
- SHB
- SBB
- SOP
- SNP

# SFG Series

## Flat Suction Cup Special for Glass Industry



### Dimensions(mm)

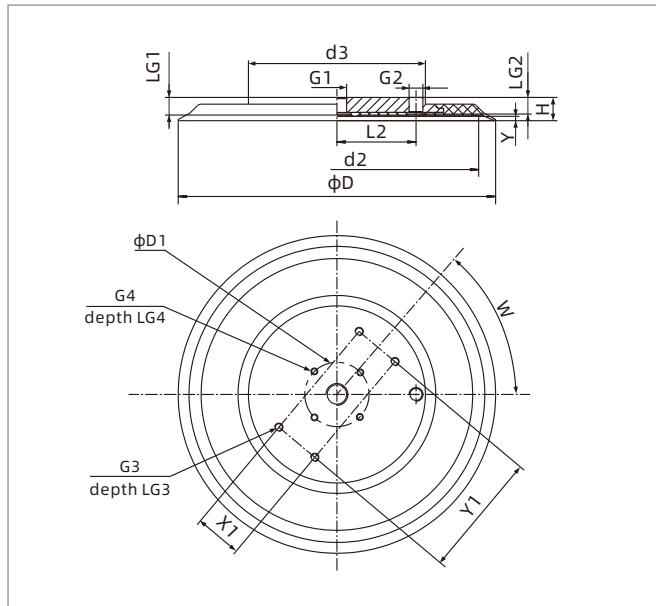
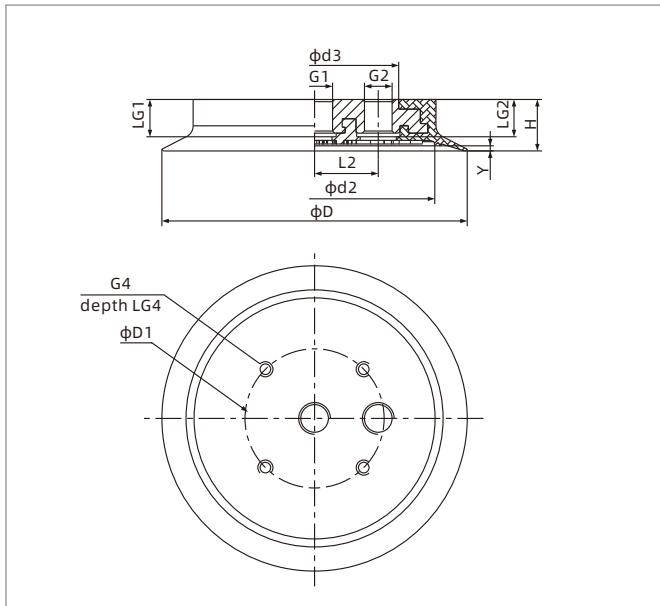

SFG125-200

SFG250-400

Model/Size	D	d2	d3	G1	G2	G3	G4	D1	H	L2	LG1	LG2	LG3	LG4	W	X1	Y1	Y
SFG125□-G2F	125	100	70	G1/4	G1/4	-	4-M6	59	21.5	26.5	14	14	-	8	-	-	-	3
SFG125□-G3F	125	100	70	G3/8	G1/4	-	4-M6	59	21.5	26.5	14	14	-	8	-	-	-	3
SFG150□-G4F	150	125	93	G1/2	G1/4	-	4-M6	59	21.5	36.5	14	14	-	8	-	-	-	3.3
SFG150H□-G4F	150	126	70	G1/2	G1/4	-	4-M6	59	26	26.5	14	14	-	8	-	-	-	7.5
SFG200□-G4F	200	185	134	G1/2	G1/4	-	4-M6	59	22	52.8	14	14	-	8	-	-	-	3.6
SFG250H□-G4F	250	217	140	G1/2	G1/4	4-M8	4-M6	59	27	52.5	14.5	14.5	12	8	70	45	100	9
SFG300H□-G4F	300	272	170	G1/2	G1/4	4-M8	4-M8	59	27	76	14.5	14.5	12	10	50	45	120	9
SFG350H□-G4F	350	317	170	G1/2	G1/4	4-M8	4-M8	59	27	76	14.5	14.5	12	10	50	45	120	9
SFG400□-G4F	400	372	170	G1/2	G1/4	4-M8	4-M8	59	22.5	76	14.5	14.5	12	10	50	45	120	4.5

◇ Note: The dimensional tolerance conforms to GB/T3672.1-2002-1 M3 rubber product dimensional tolerance standard

### Mounting parts

Item	Model	Applicable suction cup
Rubber parts for suction cup	SFG125E SFG125HD	SFG125□-G2F SFG125□-G3F
	SFG150E SFG150HD	SFG150□-G4F
	SFG150HE SFG150HHD	SFG150H□-G4F
	SFG200E SFG200HD	SFG200□-G4F

◇ Note: When you buy rubber parts only, pls ensure that the fitting for suction cup you buy is in good condition, and send it back to factory to replace the rubber parts

# SFGT Series

## Big Flat Suction Cup

**AIRBEST**



Suction Cup

### Features

- ◇ Multilayer sealing lip
- ◇ Small inner volume
- ◇ Internal multipoint support structure

### Advantages

- ◇ Excellent airtightness, large suction force
- ◇ Short work cycle
- ◇ Prevent workpieces from side slipping
- ◇ Rubber parts can be replaced separately, reduce customer's cost greatly



### Applications

- ◇ Flat workpiece with smooth or slightly rough surface
- ◇ Metal sheet
- ◇ Glass

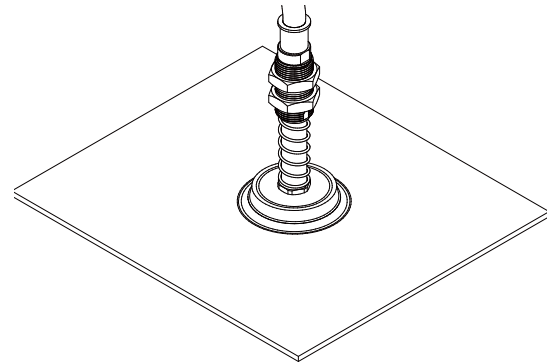

### Structure

- ◇ Fitting for suction cup and rubber parts are split structure design, wearing parts can be replaced separately

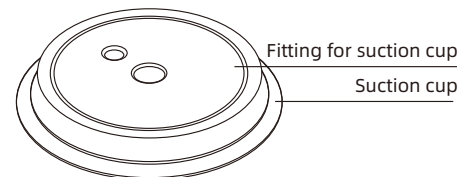

- ◇ Note: The functional threaded hole is sealed with a plug when delivered. Seal the thread with thread glue or raw tape when connecting

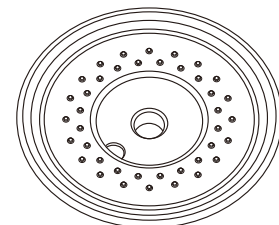

SZ  
SPH  
SP3  
SUF  
SAN  
SAO  
SOFA  
STP  
SFT  
SFA  
SBT  
SBL  
SBLP  
SBS  
SFP  
SBP  
SXP  
SGP  
SBOF  
STC  
SFF  
SOB  
SOF  
SOG  
SFM  
SOM  
SBF  
SDM  
SFU  
SFK  
SHT  
SDL  
SFG  
**SFGT**  
SFD  
SB  
SBA  
SF  
SU  
SP2F  
SPA  
SPD  
SPF  
SPC  
SPJ  
SPU  
SH  
SHB  
SBB  
SOP  
SNP

# SFGT Series

## Big Flat Suction Cup

### How to order

## SFGT 120 WS - G3F

① ② ③ ④

① Series	② Diameter	③ Material & Hardness	④ Connection thread
SFGT	65 - $\phi$ 65mm 90 - $\phi$ 90mm 120 - $\phi$ 120mm 160 - $\phi$ 160mm	WS - White silicone <span style="border: 1px solid black; padding: 0 2px;">50</span>	Nil - Suction cup only G3F - G3/8 female thread G4F - G1/2 female thread

### Technical parameters

Model	Pull-out force N	Inner volume cm <sup>3</sup>	Recommended hose Dia. mm	Weight g	MPQ pcs
SFGT65-G3F	110	3.5	8	48	1
SFGT90-G3F	320	11	8	110	1
SFGT120-G3F	550	25	10	226	1
SFGT160-G4F	1010	81	10	584	1

◇ Note: Testing vacuum level -60kPa, workpiece with smooth and clean surface. The data of pull-out force as above are figured out without considering safety factor. The data may be different according to different workpiece surfaces. Recommend the length of vacuum hose to be as short as possible, max 2m.

### Dimensions mm

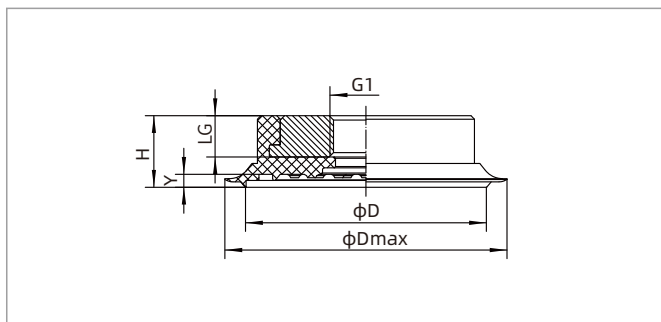

SFGT65-SFGT90

Model/Size	$\phi$ Dmax	$\phi$ D	G1	H	Y	LG
SFGT65-G3F	65	55	G3/8	16.5	3	9.5
SFGT90-G3F	90	79.5	G3/8	17	2.5	11

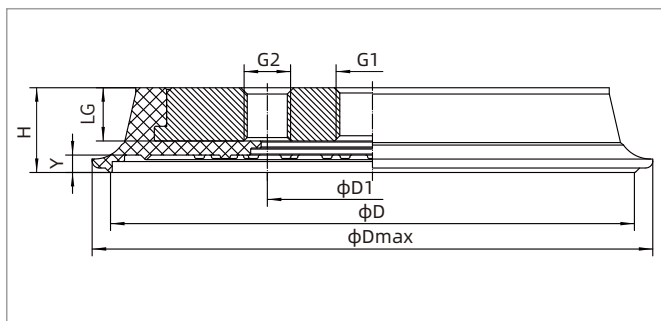

SFGT120-SFGT160

Model/Size	$\phi$ Dmax	$\phi$ D	$\phi$ D1	G1	G2	H	Y	LG
SFGT120-G3F	120	108	52	G3/8	G1/4	17.4	2.9	11
SFGT160-G4F	160	150	60	G1/2	G1/4	24.4	5.2	15.2

◇ Note: 1. The dimensional tolerance conforms to GBT3672.1-2002-1 M3 rubber product dimensional tolerance standard.  
2. Dmax is outer diameter of the suction cup when it is completely compressed

# SFD Series

## Flat Suction Cup Special for Wood Industry

**AIRBEST**



Suction Cup

### Features

- ◇ Double sealing lip
- ◇ With large area support structure at the bottom

### Advantages

- ◇ Excellent airtightness for workpieces with rough or smooth surfaces
- ◇ Prevent thin workpiece from permanent deformation

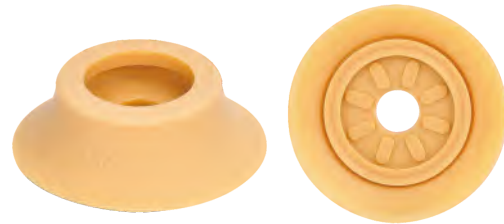

### Applications

- ◇ Suitable for even workpiece with slightly rough surface, such as wooden plate, wooden floor, wooden doors, etc

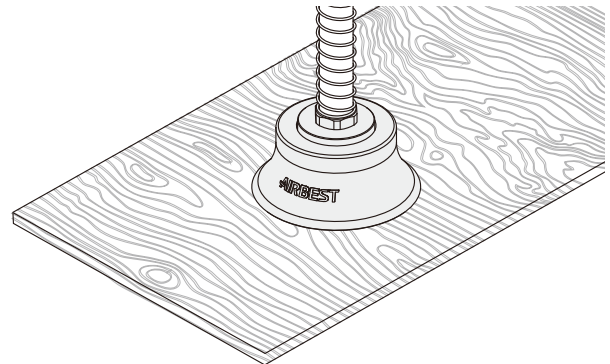

### Structure

- ◇ Double sealing lip
- ◇ Suction cup and fitting are split structure design, wearing parts can be replaced separately

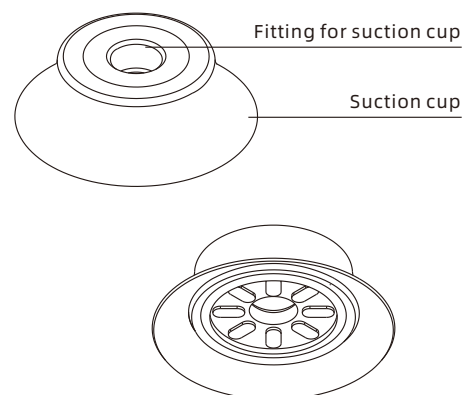

SZ  
SPH  
SP3  
SUF  
SAN  
SAO  
SOFA  
STP  
SFT  
SFA  
SBT  
SBL  
SBLP  
SBS  
SFP  
SBP  
SXP  
SGP  
SBOF  
STC  
SFF  
SOB  
SOF  
SOG  
SFM  
SOM  
SBF  
SDM  
SFU  
SFK  
SHT  
SDL  
SFG  
SFGT  
**SFD**  
SB  
SBA  
SF  
SU  
SP2F  
SPA  
SPD  
SPF  
SPC  
SPJ  
SPU  
SH  
SHB  
SBB  
SOP  
SNP

# SFD Series

Flat Suction Cup Special for Wood Industry



## How to order

### SFD 40 NR - G1F

① ② ③ ④

① Series	② Diameter	③ Material & Hardness	④ Connection thread
SFD	40 - $\phi$ 40mm	N - NBR <span style="background-color: black; color: white; padding: 2px;">55</span>	Nil - Suction cup only
	70 - $\phi$ 70mm	WS - White silicone <span style="border: 1px solid black; padding: 2px;">50</span>	G1F - G1/8 female thread
		NR - Natural rubber <span style="background-color: orange; padding: 2px;">40</span>	G2F - G1/4 female thread

## Selection

Model	Connection thread F - Female thread
SFD40□	SFD40□-G1F
SFD70□	SFD70□-G2F

## Technical parameters

Model	Pull-out force N	Inner volume cm <sup>3</sup>	Min.curve radius of workpiece mm	Weight g	Recommended hose dia. mm	MPQ pcs
SFD40	60	3.8	48	4.8	8	1
SFD70	185	25	85	32.2	8	1

◇ Note: Testing vacuum level -60kPa, workpiece with smooth and clean surface. The data of pull-out force as above are figured out without considering safety factor. The data may be different according to different workpiece surfaces. Recommend the length of vacuum hose to be as short as possible, max 2m.

## Dimensions(mm)

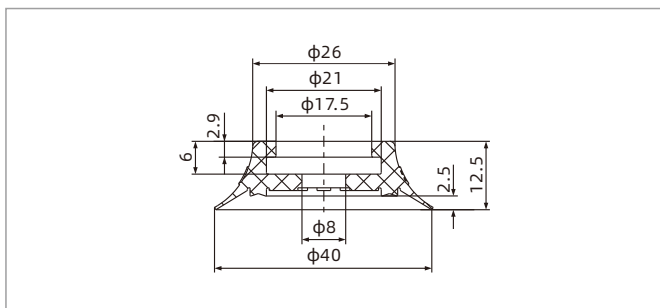

SFD40

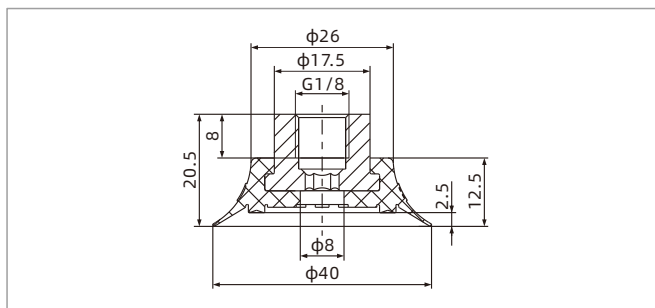

SFD40□-G1F

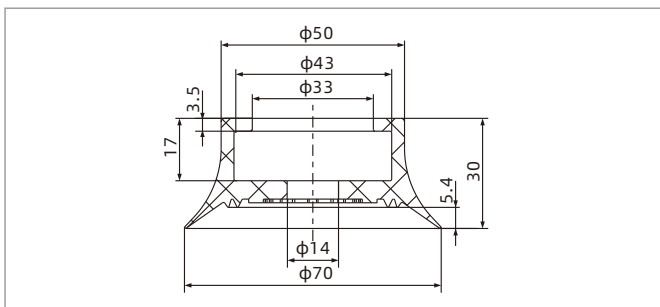

SFD70

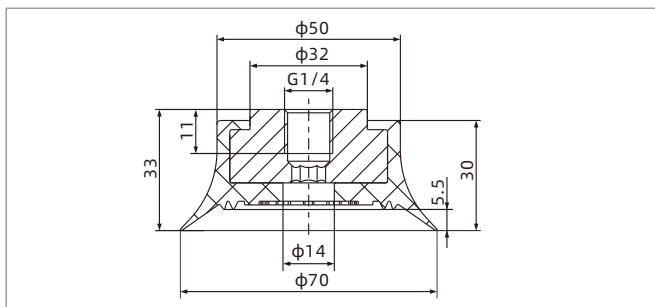

SFD70□-G2F

◇ Note: The dimensional tolerance conforms to GB/T3672.1-2002-1 M3 rubber product dimensional tolerance standard

# SB Series

## Universal Bellows Suction Cup



UNIVERSAL



### Features

- ◇ 1.5 Bellows
- ◇ Support structure at the bottom
- ◇ Various sizes for option

### Advantages

- ◇ Easy to fit uneven surface of workpiece, and has buffer effect
- ◇ Handling thin workpiece without permanent deformation
- ◇ Suitable for workpieces with different sizes and shapes



### Applications

- ◇ Handling of workpieces with uneven surface, such as carton, cardboard, cambered workpiece, pipe, etc
- ◇ Handling fragile workpieces, such as electronic components, plastic injection parts, etc
- ◇ Handling smooth wood plate, smooth steel plate and so on

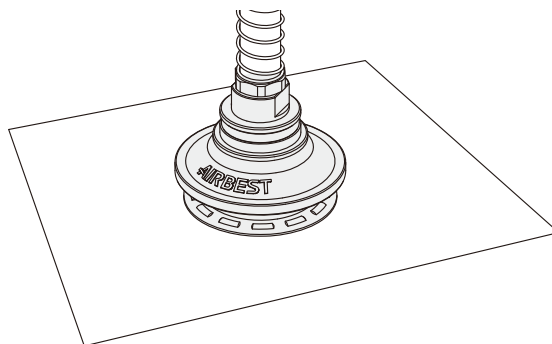

### Structure

- ◇ 1.5 Bellows, large compressed stroke.
- ◇ Suction cup and fitting are split structure design, wearing parts can be replaced separately.

In same series, replacement suction cup and fitting can be combined on request.

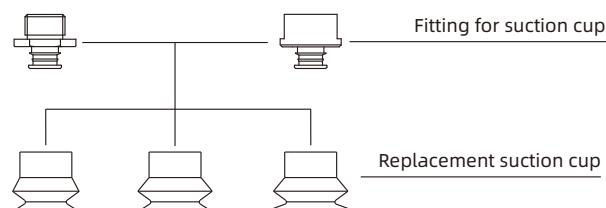

- SZ
- SPH
- SP3
- SUF
- SAN
- SAO
- SOFA
- STP
- SFT
- SFA
- SBT
- SBL
- SBLP
- SBS
- SFP
- SBP
- SXP
- SGP
- SBOF
- STC
- SFF
- SOB
- SOE
- SOG
- SFM
- SOM
- SBF
- SDM
- SFU
- SFK
- SHT
- SDL
- SFG
- SFGT
- SFD
- SB**
- SBA
- SF
- SU
- SP2F
- SPA
- SPD
- SPF
- SPC
- SPJ
- SPU
- SH
- SHB
- SBB
- SOP
- SNP

# SB Series

## Universal Bellows Suction Cup

### How to order

## SB 30 N - G1M - EW

①      ②      ③      ④      ⑤

① Series	② Diameter	③ Material & Hardness	④ Connection thread	⑤ Special specification	
SB	5 - φ5mm	20 - φ20mm	N - NBR	55 Nil - Suction cup only	Nil - Standard
	6 - φ6mm	30 - φ30mm	S - Silicone	50 M5M - M5×0.8 male thread	EW - With mesh filter
	8 - φ8mm	40 - φ40mm	WS - White silicone	50 G1M - G1/8 male thread	EH - With throttle valve
	10 - φ10mm	50 - φ50mm	CS - Conductive silicone	55 G2M - G1/4 male thread	
	12 - φ12mm	75 - φ75mm		G3M - G3/8 male thread	
	15 - φ15mm	110 - φ110mm		G1F - G1/8 female thread	
	17 - φ17mm	150 - φ150mm		G2F - G1/4 female thread	
				G3F - G3/8 female thread	
			G4F - G1/2 female thread		

### Selection

Model	Connection thread	
	M - Male thread	F - Female thread
SB5□	SB5□-M5M	-
SB6□	SB6□-M5M	-
SB8□	SB8□-M5M	-
SB10□	SB10□-M5M	-
SB12□	SB12□-M5M	-
SB15□	SB15□-M5M	-
SB17□	SB17□-G1M(-EW/EH)	SB17□-G1F(-EW/EH)
SB20□	SB20□-G1M(-EW/EH)	SB20□-G1F(-EW/EH)
SB30□	SB30□-G1M(-EW/EH)	SB30□-G1F(-EW/EH)
SB40□	SB40□-G1M(-EW/EH)	SB40□-G1F(-EW/EH)
SB50□	SB50□-G2M(-EW/EH)    SB50□-G3M(-EW/EH)	SB50□-G2F(-EW/EH)    SB50□-G3F(-EW/EH)
SB75□	-	SB75□-G2F
SB110□	-	SB110□-G4F
SB150□	-	SB150□-G4F

# SB Series

## Universal Bellows Suction Cup

### Technical parameters

Model	Pull-out force N	Inner volume cm <sup>3</sup>	Min.curve radius of workpiece mm	Weight g	Recommended hose dia. mm	MPQ pcs
SB5	0.8	<0.1	8	0.3	4	10
SB6	1.2	<0.1	8	0.5	4	10
SB8	2.1	<0.1	10	0.4	4	10
SB10	3.2	0.4	12	0.9	4	10
SB12	4.7	0.5	15	1.5	6	10
SB15	7.4	0.8	20	1.5	6	10
SB17	9.5	1.1	25	1	6	10
SB20	18	1.2	30	3	6	5
SB30	33	14	35	7.5	6	5
SB40	60	18	50	13	6	5
SB50	92	26	80	24	8	1
SB75	210	96	60	68	8	1
SB110	412	314	120	178	12	1
SB150	740	798	160	439.5	12	1

◇ Note: Testing vacuum level -60kPa, workpiece with smooth and clean surface. The data of pull-out force as above are figured out without considering safety factor. The data may be different according to different workpiece surfaces. Recommend the length of vacuum hose to be as short as possible, max 2m.

### Dimensions(mm) - Suction cup only

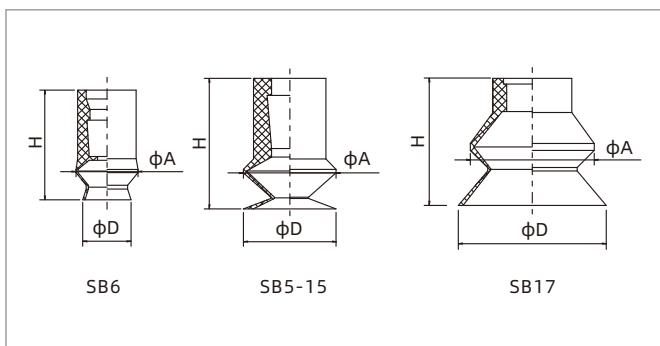

Model/Size	D	A	H
SB5□	5.8	6.2	9.2
SB6□	7	9	13.5
SB8□	8.8	9.6	11.9
SB10□	11	12	16
SB12□	12	14	16.5
SB15□	17.5	17.5	19.5
SB17□	18.5	16.6	15.6

SB

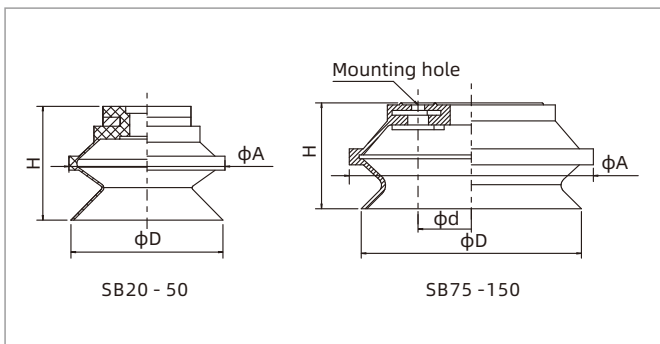

Model/Size	D	A	H	d	Mounting hole
SB20□	22	24	19	-	-
SB30□	34	36	26	-	-
SB40□	43	46	28	-	-
SB50□	53	58	35	-	-
SB75□	78	83	37	35	4-φ6
SB110□	115	124	54	55	8-φ6
SB150□	155	166	71	70.5	8-φ6

SB

SZ

SPH

SP3

SUF

SAN

SAO

SOFA

STP

SFT

SFA

SBT

SBL

SBLP

SBS

SFP

SBP

SXP

SGP

SBOF

STC

SFF

SOB

SOF

SOG

SFM

SOM

SBF

SDM

SFU

SFK

SHT

SDL

SFG

SFGT

SFD

SB

SBA

SF

SU

SP2F

SPA

SPD

SPF

SPC

SPJ

SPU

SH

SHB

SBB

SOP

SNP

# SB Series

## Universal Bellows Suction Cup

### Dimensions(mm) - Suction cup with fitting

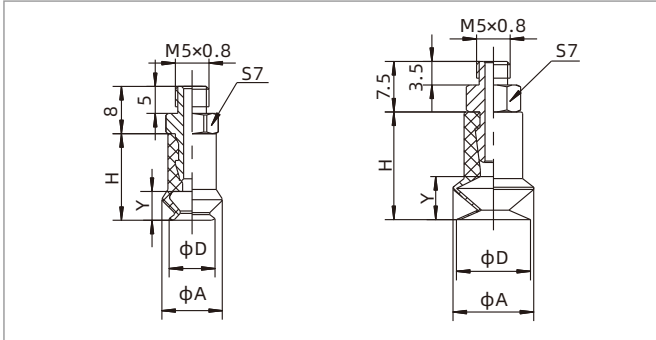

SB6□-M5M

SB□□-M5M

Model/Size	D	A	H	Y
SB5□-M5M	5.8	6.2	9.2	3.6
SB6□-M5M	7	9	13.5	4.5
SB8□-M5M	8.8	9.6	11.9	6.5
SB10□-M5M	11	12	16	7
SB12□-M5M	12	14	16.5	5.5
SB15□-M5M	15.5	17.5	19.5	10

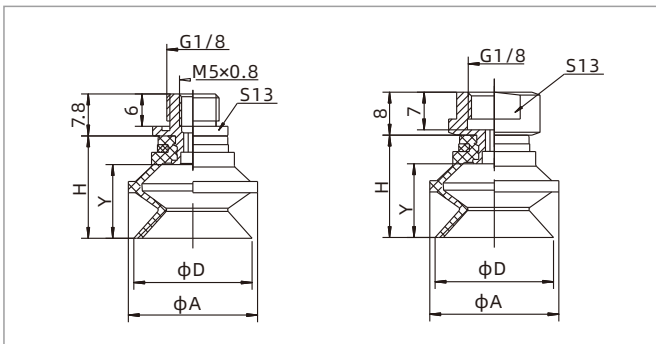

SB□□-G1M

SB□□-G1F

Model/Size	D	A	H	Y
SB17□-G1M	18.5	16.6	15.6	10.5
SB17□-G1F	18.5	16.6	15.6	10.5
SB20□-G1M	22	24	19	9
SB20□-G1F	22	24	19	9

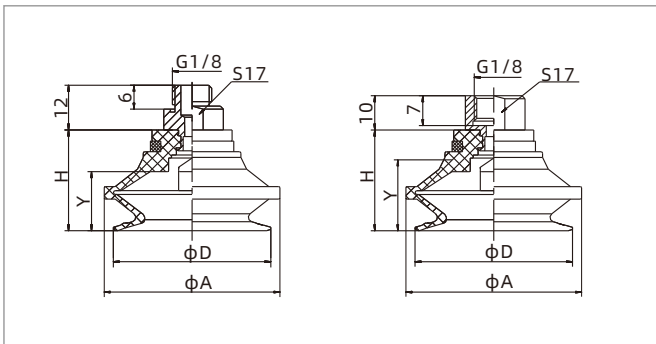

SB□□-G1M

SB□□-G1F

Model/Size	D	A	H	Y
SB30□-G1M	34	36	26	19
SB30□-G1F	34	36	26	19
SB40□-G1M	43	46	28	20
SB40□-G1F	43	46	28	20

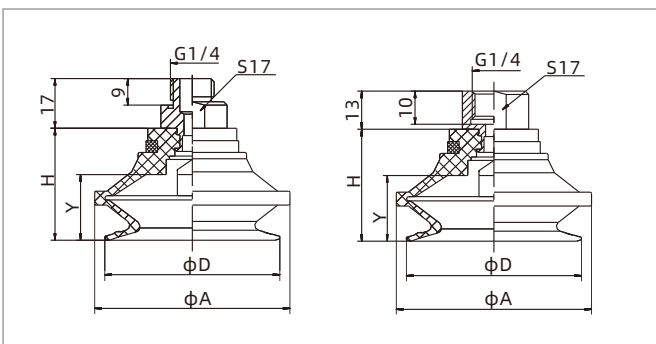

SB50□-G2M

SB50□-G2F

Model/Size	D	A	H	Y
SB50□-G2M	53	58	35	20
SB50□-G2F	53	58	35	20

# SB Series

## Universal Bellows Suction Cup

### Dimensions(mm) - Suction cup with fitting

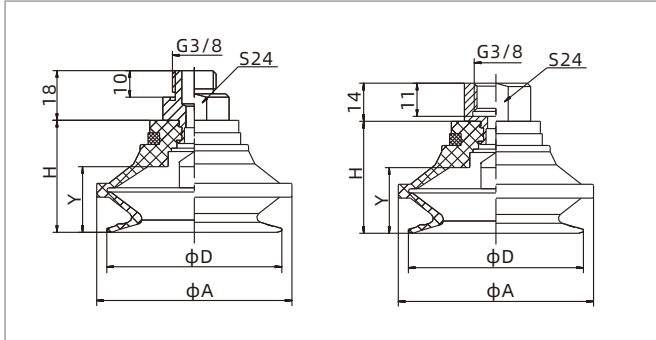

SB50□-G3M

SB50□-G3F

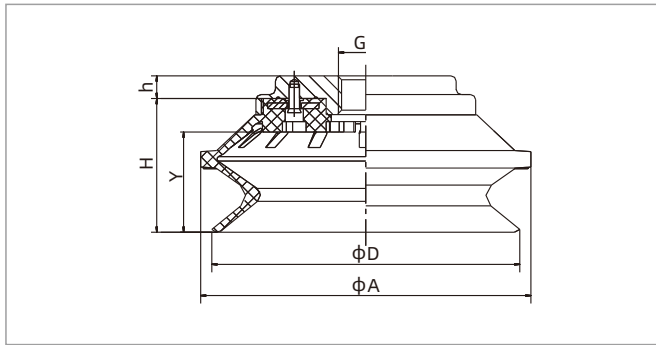

SB75-150

◇ Note: The dimensional tolerance conforms to GBT3672.1-2002-1 M3 rubber product dimensional tolerance standard

Model/Size	D	A	H	Y
SB50□-G3M	53	58	35	20
SB50□-G3F	53	58	35	20

Model/Size	D	A	H	h	G	Y
SB75□-G2F	78	83	37	13	G1/4	27
SB110□-G4F	115	124	54	9	G1/2	38.5
SB150□-G4F	155	166	71	10	G1/2	44.5

### Mounting parts

Item	Model		Applicable suction cup
	M - Male thread	F - Female thread	
Fitting for suction cup	PJS-M5M-SC1	-	SB6
	PJS-M5M-SC2	-	SB5,8
	PJS-M5M-SC3	-	SB10,12,15
	PJS-G1M-SF1	PJS-G1F-SF1	SB17,20
	PJS-G1M-SF2	PJS-G1F-SF2	SB30,40
	PJS-G2M-SF3	PJS-G2F-SF3	SB50
	PJS-G3M-SF3	PJS-G3F-SF3	SB50
	-	PJS-G2F-SF75	SB75
	-	PJS-G4F-SF110	SB110
	-	PJS-G4F-SF150	SB150

- SZ
- SPH
- SP3
- SUF
- SAN
- SAO
- SOFA
- STP
- SFT
- SFA
- SBT
- SBL
- SBLP
- SBS
- SFP
- SBP
- SXP
- SGP
- SBOF
- STC
- SFF
- SOB
- SOF
- SOG
- SFM
- SOM
- SBF
- SDM
- SFU
- SFK
- SHT
- SDL
- SFG
- SFGT
- SFD
- SB**
- SBA
- SF
- SU
- SP2F
- SPA
- SPD
- SPF
- SPC
- SPJ
- SPU
- SH
- SHB
- SBB
- SOP
- SNP

# SBA Series

## 1.5 Bellows Suction Cup

AIRBEST



### Features

- ◇ 1.5 Bellows
- ◇ Special material with high temperature resistance is optional
- ◇ Various sizes for option

### Advantages

- ◇ Easy to fit uneven surface of workpiece, has buffer effect
- ◇ Can handle workpiece with high temperature
- ◇ Fitting can be used repeatedly, greatly reducing customer's cost
- ◇ Suitable for workpieces with different sizes and shapes



### Applications

- ◇ Handling of workpieces with uneven surface, such as carton, cardboard, cambered workpiece, pipe, etc.
- ◇ Handling high temperature plastic injection parts, metal sheet, glass, etc.
- ◇ Handling smooth wood plate, smooth steel plate and so on

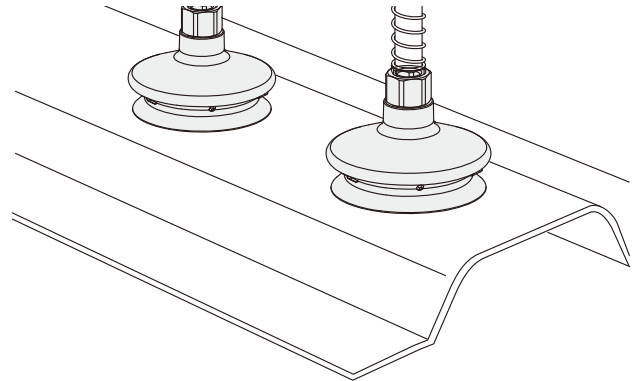

### Structure

- ◇ 1.5 Bellows, large compressed stroke
- ◇ Suction cup and fitting are split structure design, wearing parts can be replaced separately
- ◇ Mark free plug is optional, for grasping without any mark

In same series, replacement suction cup and fitting can be combined on request.

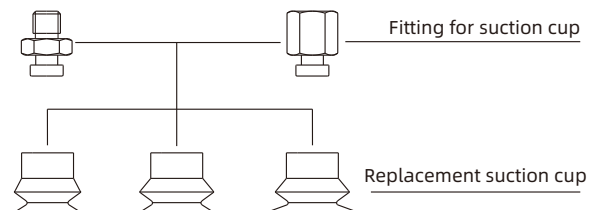

# SBA Series

## 1.5 Bellows Suction Cup

### How to order

## SBA 33 N - G2M - PK

① ② ③ ④ ⑤

① Series	② Diameter	③ Material & Hardness	④ Connection thread	⑤ Special specification
SBA	6 - φ6mm	27 - φ27mm	N - NBR	55 Nil - Suction cup only Nil - Standard type
	11 - φ11mm	33 - φ33mm	WS - White silicone	50 M5M - M5×0.8 male thread PK - With mark free plug
	14 - φ14mm	43 - φ43mm	HD - High temp/Mark free	60 G1M - G1/8 male thread
	16 - φ16mm	53 - φ53mm	NR - Natural rubber	40 G2M - G1/4 male thread
	20 - φ20mm	63 - φ63mm		M5F - M5×0.8 female thread
	22 - φ22mm	78 - φ78mm		G1F - G1/8 female thread
	25 - φ25mm			G2F - G1/4 female thread

### Selection

Model	Connection thread M - Male thread	F - Female thread
SBA6□	SBA6□-M5M	SBA6□-M5F
SBA11□	SBA11□-M5M SBA11□-G1M	SBA11□-M5F SBA11□-G1F
SBA14□	SBA14□-M5M SBA14□-G1M	SBA14□-M5F SBA14□-G1F
SBA16□	SBA16□-M5M SBA16□-G1M	SBA16□-M5F SBA16□-G1F
SBA20□	SBA20□-M5M SBA20□-G1M	SBA20□-M5F SBA20□-G1F
SBA22□	SBA22□-M5M SBA22□-G1M	SBA22□-M5F SBA22□-G1F
SBA25□	SBA25□-M5M SBA25□-G1M	SBA25□-M5F SBA25□-G1F
SBA27□	SBA27□-G2M	SBA27□-G2F
SBA33□	SBA33□-G2M	SBA33□-G2F
SBA43□	SBA43□-G2M	SBA43□-G2F
SBA53□	SBA53□-G2M	SBA53□-G2F
SBA63□	SBA63□-G2M	SBA63□-G2F
SBA78□	SBA78□-G2M	SBA78□-G2F

- SZ
- SPH
- SP3
- SUF
- SAN
- SAO
- SOFA
- STP
- SFT
- SFA
- SBT
- SBL
- SBLP
- SBS
- SFP
- SBP
- SXP
- SGP
- SBOF
- STC
- SFF
- SOB
- SOE
- SOG
- SFM
- SOM
- SBF
- SDM
- SFU
- SFK
- SHT
- SDL
- SFG
- SFGT
- SFD
- SB
- SBA**
- SF
- SU
- SP2F
- SPA
- SPD
- SPF
- SPC
- SPJ
- SPU
- SH
- SHB
- SBB
- SOP
- SNP

# SBA Series

## 1.5 Bellows Suction Cup

### Selection - With mark free plug

Model	M - Male thread		F - Female thread	
SBA11□-PK	SBA11□-M5M-PK	SBA11□-G1M-PK	SBA11□-M5F-PK	SBA11□-G1F-PK
SBA14□-PK	SBA14□-M5M-PK	SBA14□-G1M-PK	SBA14□-M5F-PK	SBA14□-G1F-PK
SBA16□-PK	SBA16□-M5M-PK	SBA16□-G1M-PK	SBA16□-M5F-PK	SBA16□-G1F-PK
SBA20□-PK	SBA20□-M5M-PK	SBA20□-G1M-PK	SBA20□-M5F-PK	SBA20□-G1F-PK
SBA22□-PK	SBA22□-M5M-PK	SBA22□-G1M-PK	SBA22□-M5F-PK	SBA22□-G1F-PK
SBA25□-PK	SBA25□-M5M-PK	SBA25□-G1M-PK	SBA25□-M5F-PK	SBA25□-G1F-PK
SBA27□-PK	SBA27□-G2M-PK		SBA27□-G2F-PK	
SBA33□-PK	SBA33□-G2M-PK		SBA33□-G2F-PK	
SBA43□-PK	SBA43□-G2M-PK		SBA43□-G2F-PK	
SBA53□-PK	SBA53□-G2M-PK		SBA53□-G2F-PK	

### Technical parameters

Model	Pull-out force N	Inner volume cm <sup>3</sup>	Min. curved radius of workpiece mm	Weight g	Recommended hose dia. mm	MPQ pcs
SBA6	1.4	0.1	2	0.2	4	10
SBA11	3.8	0.2	10	1.0	6	10
SBA14	5.0	0.4	13	1.1	6	10
SBA16	6.7	0.8	20	1.4	6	10
SBA20	10.7	1.2	30	1.5	6	5
SBA22	15.2	1.4	25	2.2	6	5
SBA25	17.3	3.2	20	3.1	6	5
SBA27	24.0	3.4	23	4.7	6	5
SBA33	39.6	4.8	40	7.2	6	5
SBA43	64.5	11.4	60	11.9	6	5
SBA53	95.0	26.0	75	20.2	8	1
SBA63	135.0	44.0	75	25.5	8	1
SBA78	218.0	76.0	70	52.6	8	1

◇ Note: Testing vacuum level -60kPa, workpiece with smooth and clean surface. The data of pull-out force as above are figured out without considering safety factor. The data may be different according to different workpiece surfaces. Recommend the length of vacuum hose to be as short as possible, max 2m.

# SBA Series

## 1.5 Bellows Suction Cup

### Dimensions(mm) - Suction cup only

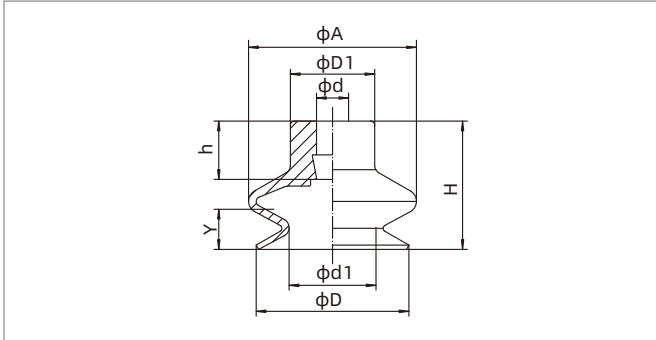

SBA6-25

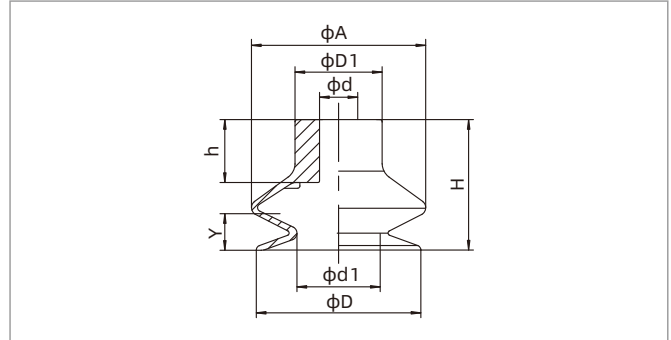

SBA27-78

Model/Size	D	H	A	D1	d	d1	h	Y
SBA6□	5.5	9	6	7	3.7	2.7	5	3
SBA11□	10.5	16	12	10	4	5	7	4
SBA14□	13	15.5	13.5	10	4	5	7	6
SBA16□	15.5	19	17	10	4	8	7	7
SBA20□	18	15	20	10	4	11	7	8
SBA22□	22	19	24	10	4	11	9	9
SBA25□	24	23	25	10	4	9.5	9	11.5
SBA27□	26	25	27.5	16	8	14	13	9
SBA33□	35	27	36	18	8	17	13	10
SBA43□	43	28	45	18	8	21.5	13	11.5
SBA53□	53	34	58	18	8	32	13	15.5
SBA63□	63	33.5	66	18	8	43.5	13	15
SBA78□	78	46.5	83	25	12	54.5	20	14.5

- SZ
- SPH
- SP3
- SUF
- SAN
- SAO
- SOFA
- STP
- SFT
- SFA
- SBT
- SBL
- SBLP
- SBS
- SFP
- SBP
- SXP
- SGP
- SBOF
- STC
- SFF
- SOB
- SOF
- SOG
- SFM
- SOM
- SBF
- SDM
- SFU
- SFK
- SHT
- SDL
- SFG
- SFGT
- SFD
- SB
- SBA**
- SF
- SU
- SP2F
- SPA
- SPD
- SPF
- SPC
- SPJ
- SPU
- SH
- SHB
- SBB
- SOP
- SNP

## 1.5 Bellows Suction Cup

### Dimensions(mm) - Suction cup with fitting

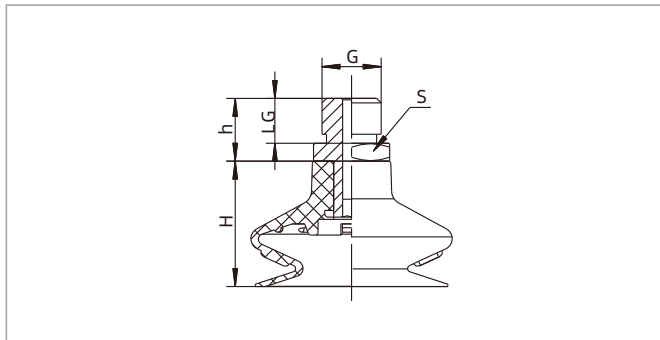

SBA - Male thread connection

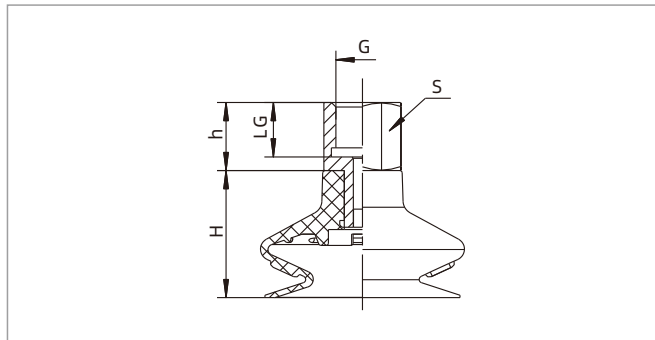

SBA - Female thread connection

Model/Size	H	h	G	LG	S
SBA6□-M5M	9	7.5	M5 × 0.8	3.5	7
SBA11□-M5M	16	7.5	M5 × 0.8	3.5	7
SBA11□-G1M	16	13.5	G1/8	7.5	14
SBA14□-M5M	15.5	7.5	M5 × 0.8	3.5	7
SBA14□-G1M	15.5	13.5	G1/8	7.5	14
SBA16□-M5M	19	7.5	M5 × 0.8	3.5	7
SBA16□-G1M	19	13.5	G1/8	7.5	14
SBA20□-M5M	15	7.5	M5 × 0.8	3.5	7
SBA20□-G1M	15	13.5	G1/8	7.5	14
SBA22□-M5M	19	7.5	M5 × 0.8	3.5	7
SBA22□-G1M	19	13.5	G1/8	7.5	14
SBA25□-M5M	23	7.5	M5 × 0.8	3.5	7
SBA25□-G1M	23	13.5	G1/8	7.5	14
SBA27□-G2M	25	15	G1/4	11	17
SBA33□-G2M	27	15	G1/4	11	17
SBA43□-G2M	28	15	G1/4	11	17
SBA53□-G2M	34	15	G1/4	11	17
SBA63□-G2M	33.5	15	G1/4	11	17
SBA78□-G2M	46.5	15	G1/4	11	21

Model/Size	H	h	G	LG	S
SBA6□-M5F	9	10	M5 × 0.8	5.5	7
SBA11□-M5F	16	10	M5 × 0.8	5.5	8
SBA11□-G1F	16	12	G1/8	8	14
SBA14□-M5F	15.5	10	M5 × 0.8	5.5	8
SBA14□-G1F	15.5	12	G1/8	8	14
SBA16□-M5F	19	10	M5 × 0.8	5.5	8
SBA16□-G1F	19	12	G1/8	8	14
SBA20□-M5F	15	10	M5 × 0.8	5.5	8
SBA20□-G1F	15	12	G1/8	8	14
SBA22□-M5F	19	10	M5 × 0.8	5.5	8
SBA22□-G1F	19	12	G1/8	8	14
SBA25□-M5F	23	10	M5 × 0.8	5.5	8
SBA25□-G1F	23	12	G1/8	8	14
SBA27□-G2F	25	15	G1/4	12	17
SBA33□-G2F	27	15	G1/4	12	17
SBA43□-G2F	28	15	G1/4	12	17
SBA53□-G2F	34	15	G1/4	12	17
SBA63□-G2F	33.5	15	G1/4	12	17
SBA78□-G2F	46.5	15	G1/4	12	21

◇ Note: The dimensional tolerance conforms to GB/T3672.1-2002-1 M3 rubber product dimensional tolerance standard

### Mounting parts

Item	Model M - Male thread	F - Female thread	Applicable suction cup
Fitting for suction cup	PJS-M5M-SBA6	PJS-M5F-SBA6	SBA6
	PJS-M5M-SC3	PJS-M5F-SC3	SBA11,14,16,20,22,25
	PJS-G1M-SC3	PJS-G1F-SC3	SBA11,14,16,20,22,25
	PJS-G2M-ST5	PJS-G2F-ST5	SBA27,33,43,53,63
	PJS-G2M-ST8	PJS-G2F-ST8	SBA78

# SF Series

## Universal Flat Suction Cup



### Features

- ◇ Support structure at the bottom
- ◇ Small inner volume
- ◇ Various sizes are available

### Advantages

- ◇ Handling thin workpiece without permanent deformation
- ◇ Short work cycle
- ◇ Suitable for workpieces with different sizes and shapes



### Applications

- ◇ Suitable for flat workpiece with smooth or slightly rough surfaces, such as smooth wood plate, smooth steel plate, plywood, plastic plate, etc.
- ◇ Suitable for handling electronic components, anti-static material can effectively prevent electrostatic damage to electronic products

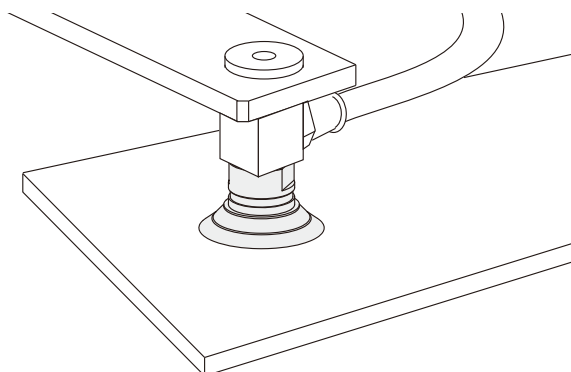

### Structure

- ◇ Suction cup and fitting are split structure design, wearing parts can be replaced separately
- ◇ Contact inductive valve is optional for suction cup with diameter  $\phi 50-150\text{mm}$ , in order to avoid accidental vacuum leakage
- ◇ Note: The functional threaded hole is sealed with a plug when delivered. Seal the thread with thread glue or raw tape when connecting

In same series, replacement suction cup and fitting can be combined on request.

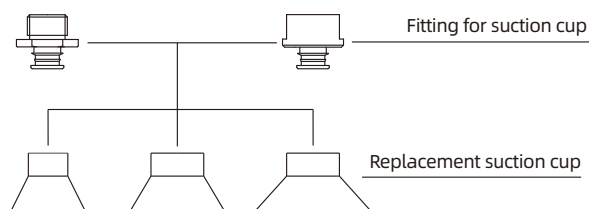

- SZ
- SPH
- SP3
- SUF
- SAN
- SAO
- SOFA
- STP
- SFT
- SFA
- SBT
- SBL
- SBLP
- SBS
- SFP
- SBP
- SXP
- SGP
- SBOF
- STC
- SFF
- SOB
- SOF
- SOG
- SFM
- SOM
- SBF
- SDM
- SFU
- SFK
- SHT
- SDL
- SFG
- SFGT
- SFD
- SB
- SBA
- SF
- SU
- SP2F
- SPA
- SPD
- SPF
- SPC
- SPJ
- SPU
- SH
- SHB
- SBB
- SOP
- SNP

# SF Series

## Universal Flat Suction Cup

### How to order

SF 50 N - G2F - EB  
①      ②      ③              ④              ⑤

① Series	② Diameter	③ Material & Hardness	④ Connection thread	⑤ Special specification	
SF	15 - φ15mm	N - NBR	<b>55</b> Nil	Suction cup only	Nil - Standard
	20 - φ20mm	S - Silicone	<b>50</b> M5M	M5×0.8 male thread	EB - With contact inductive valve
	25 - φ25mm	WS - White silicone	<b>50</b> G1M	G1/8 male thread	EW - With mesh filter
	30 - φ30mm	CS - Conductive silicone	<b>55</b> G2M	G1/4 male thread	EH - With throttle valve
	40 - φ40mm		G3M	G3/8 male thread	
	50 - φ50mm		G1F	G1/8 female thread	
	75 - φ75mm		G2F	G1/4 female thread	
	110 - φ110mm		G3F	G3/8 female thread	
	150 - φ150mm		G4F	G1/2 female thread	
	200 - φ200mm		G6F	G3/4 female thread	
	300 - φ300mm				

### Selection

Model	Connection thread	
	M - Male thread	F - Female thread
SF15□	SF15□-M5M	-
SF20□	SF20□-G1M(-EW/EH)	SF20□-G1F(-EW/EH)
SF25□	SF25□-G1M(-EW/EH)	SF25□-G1F(-EW/EH)
SF30□	SF30□-G1M(-EW/EH)	SF30□-G1F(-EW/EH)
SF40□	SF40□-G1M(-EW/EH)	SF40□-G1F(-EW/EH)
SF50□	SF50□-G2M(-EW/EH)    SF50□-G3M(-EW/EH)	SF50□-G2F(-EW/EH/EB)    SF50□-G3F(-EW/EH)
SF75□	-	SF75□-G2F    SF75□-G2F-EB
SF110□	-	SF110□-G4F    SF110□-G4F-EB
SF150□	-	SF150□-G4F    SF150□-G4F-EB
SF200□	-	SF200□-G4F
SF300□	-	SF300□-G6F

# SF Series

## Universal Flat Suction Cup

### Technical parameters

Model	Pull-out force N	Inner volume cm <sup>3</sup>	Weight g	Recommended hose dia. mm	MPQ pcs
SF15	8	0.5	0.7	6	10
SF20	14.5	0.8	1.4	6	5
SF25	22	1.2	1.8	6	5
SF30	32	1.5	2.6	6	5
SF40	60	3	5.2	6	5
SF50	88	7	11.5	6	1
SF75	200	20	47.2	8	1
SF110	430	60	116	10	1
SF150	795	160	344.2	10	1
SF200	1,500	550	732.2	12	1
SF300	3,200	730	2,700	12	1

◇ Note: Testing vacuum level -60kPa, workpiece with smooth and clean surface. The data of pull-out force as above are figured out without considering safety factor. The data may be different according to different workpiece surfaces. Recommend the length of vacuum hose to be as short as possible, max 2m.

### Dimensions(mm) - Suction cup only

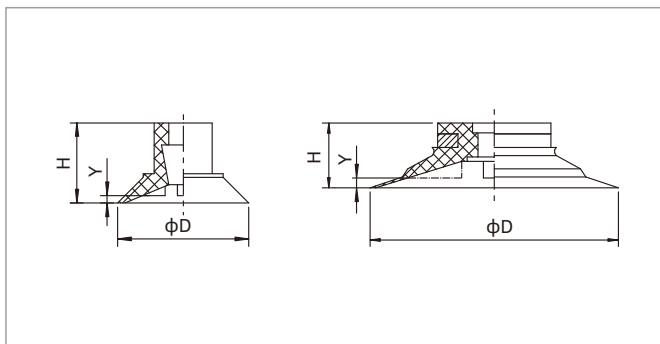

SF15

SF20-50

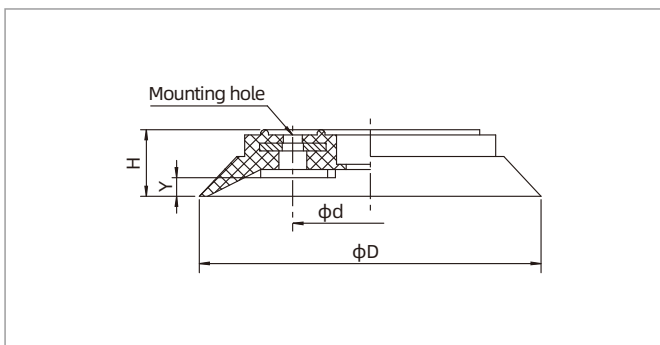

SF75-200

◇ Note: The dimensional tolerance conforms to GBT3672.1-2002-1 M3 rubber product dimensional tolerance standard

Model/Size	D	H	Y
SF15□	16.5	11	0.8
SF20□	22	8	1
SF25□	27	9	1
SF30□	32	10	1.2
SF40□	42	13	1.2
SF50□	53	17.5	3.2

Model/Size	D	H	d	Y	Mounting hole
SF75□	77	13	35	4	4-φ6
SF110□	112	20	55	6	8-φ6
SF150□	152	26	70	8	8-φ6
SF200□	200	45	40	20	4-φ9

SZ

SPH

SP3

SUF

SAN

SAO

SOFA

STP

SFT

SFA

SBT

SBL

SBLP

SBS

SFP

SBP

SXP

SGP

SBOF

STC

SFF

SOB

SOE

SOG

SFM

SOM

SBF

SDM

SFU

SFK

SHT

SDL

SFG

SFGT

SFD

SB

SBA

SF

SU

SP2F

SPA

SPD

SPF

SPC

SPJ

SPU

SH

SHB

SBB

SOP

SNP

# SF Series

## Universal Flat Suction Cup

### Dimensions(mm) - Suction cup with fitting

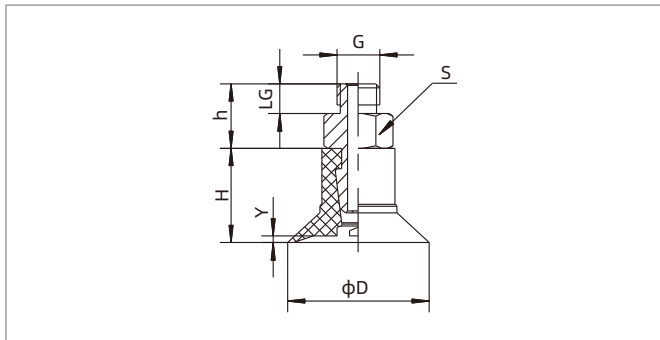

SF15□-M5M Male thread connection

Model/Size	D	H	G	LG	h	S	Y
SF15□-M5M	16.5	11	M5×0.8	3.5	7.5	7	0.8

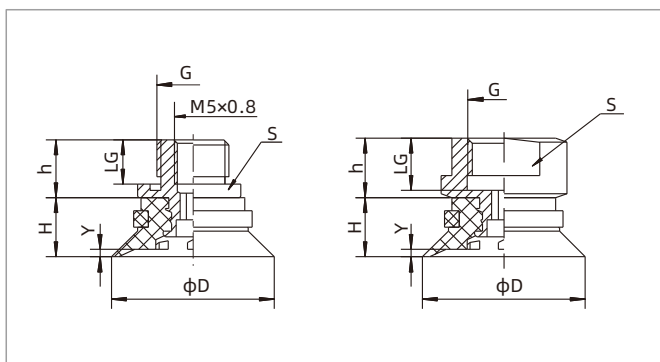

SF20-30 Male thread connection

SF20-30 Female thread connection

Model/Size	D	H	G	LG	h	S	Y
SF20□-G1M	22	8	G1/8	6	7.8	13	1
SF20□-G1F	22	8	G1/8	7	8	13	1
SF25□-G1M	27	9	G1/8	6	7.8	13	1
SF25□-G1F	27	9	G1/8	7	8	13	1
SF30□-G1M	32	10	G1/8	6	7.8	13	1.2
SF30□-G1F	32	10	G1/8	7	8	13	1.2

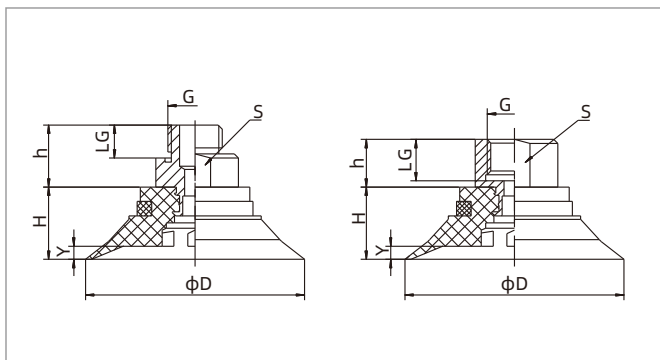

SF40-50 Male thread connection

SF40-50 Female thread connection

Model/Size	D	H	G	LG	h	S	Y
SF40□-G1M	42	13	G1/8	6	12	17	1.2
SF40□-G1F	42	13	G1/8	7	10	17	1.2
SF50□-G2M	53	17.5	G1/4	9	17	24	3.2
SF50□-G2F	53	17.5	G1/4	10	13	24	3.2
SF50□-G3M	53	17.5	G3/8	10	18	24	3.2
SF50□-G3F	53	17.5	G3/8	11	13	24	3.2

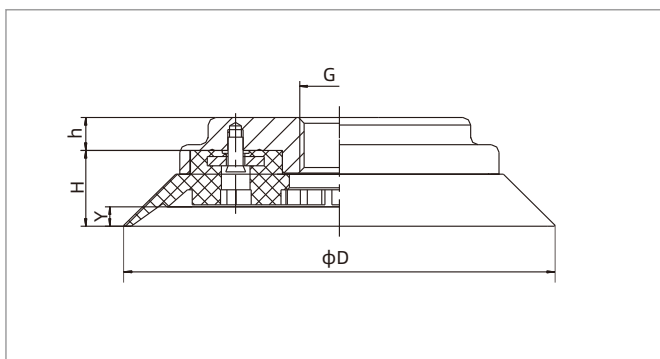

SF75-150 Female thread connection

Model/Size	D	H	G	h	Y
SF75□-G2F	77	13	G1/4	13	4
SF110□-G4F	112	20	G1/2	9	6
SF150□-G4F	152	26	G1/2	10	8

# SF Series

## Universal Flat Suction Cup

### Dimensions(mm) - Suction cup with fitting

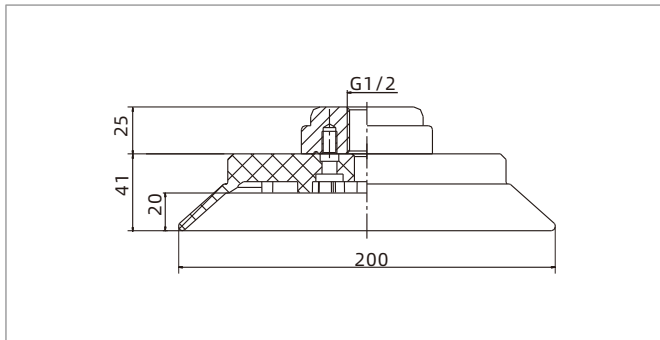

SF200 Female thread connection

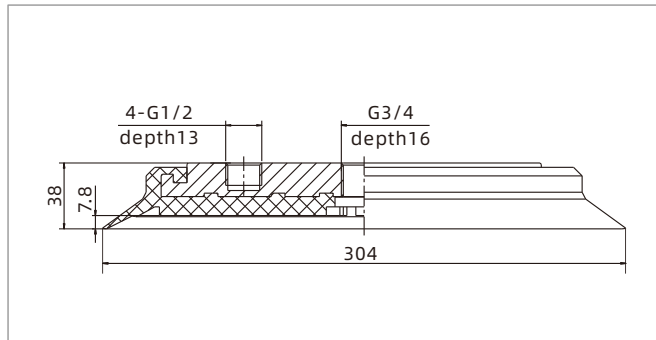

SF300 Female thread connection

### Accessories

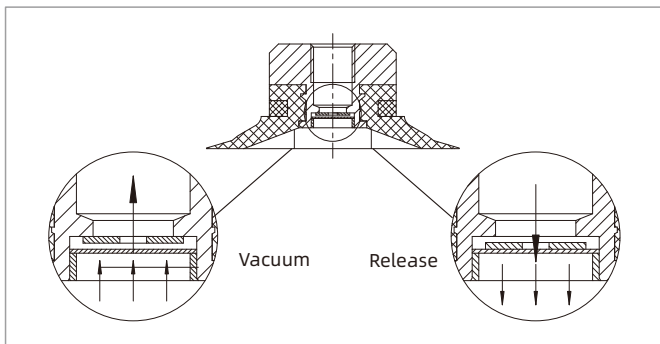

EH - Throttle valve

#### EH - Throttle valve

- ◇ The flow through the vacuum port increases when the suction cup doesn't contact the workpiece, the valve plate fits the vacuum port, just little vacuum flow leaks from the small hole
- ◇ The flow through the vacuum port reduces when the suction cup sucks the workpiece, the valve plate leaves the vacuum port, suction cup works normally. (Suction cup must work vertically when it is equipped with throttle valve)

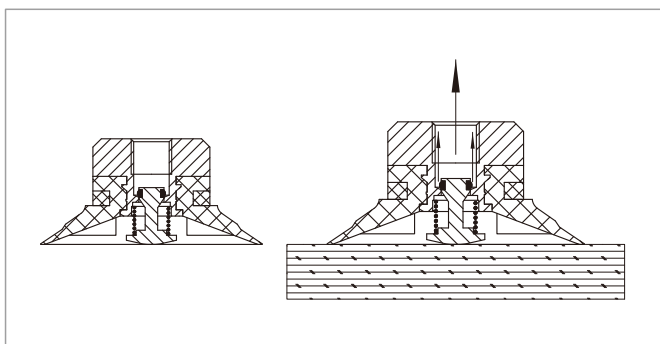

EB - Contact inductive valve

#### EB - Contact inductive valve

- ◇ When the suction cup doesn't contact the workpiece, the inductive valve closes the vacuum port to prevent the vacuum flow leakage
- ◇ When the suction cup contacts the workpiece, compresses the valve rod of the inductive valve, the vacuum port opens and the suction cup works normally

◇ Note: The contact inductive valve should be used with PSPT-H, PSPH and PSPD series level compensators. Otherwise, the spring force of inductive valve is higher than that of the level compensator, which results in the failure to open the valve. Please contact us for more details.

- SZ
- SPH
- SP3
- SUF
- SAN
- SAO
- SOFA
- STP
- SFT
- SFA
- SBT
- SBL
- SBLP
- SBS
- SFP
- SBP
- SXP
- SGP
- SBOF
- STC
- SFF
- SOB
- SOE
- SOG
- SFM
- SOM
- SBF
- SDM
- SFU
- SFK
- SHT
- SDL
- SFG
- SFGT
- SFD
- SB
- SBA
- SF
- SU
- SP2F
- SPA
- SPD
- SPF
- SPC
- SPJ
- SPU
- SH
- SHB
- SBB
- SOP
- SNP

# SF Series

## Universal Flat Suction Cup

### Dimensions(mm) - With contact inductive valve

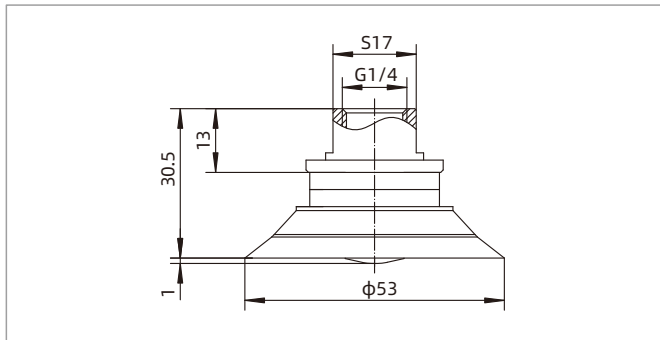

SF50□-G2F-EB

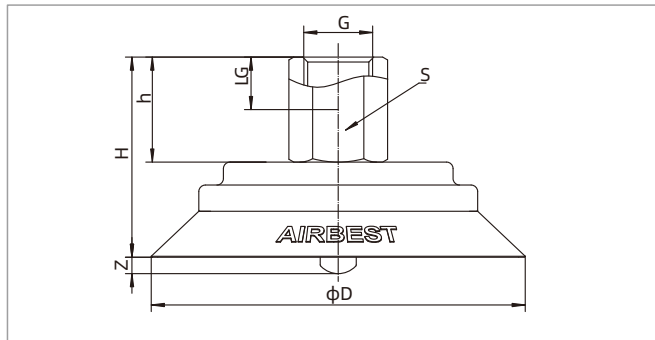

SF75-150

Model/Size	D	H	h	G	LG	S	Z	Spring force N
SF75-G2F-EB	77	58	32	G1/4	10	27	5	13
SF75-G4F-EB	77	58	32	G1/2	15	27	5	13
SF110-G4F-EB	112	61	32	G1/2	15	27	5	15
SF150-G4F-EB	152	69	32	G1/2	15	27	5	16

◇ Note: The spring force is the min. pressure required when the suction cup is attached to the surface of the workpiece and the inductive valve is fully opened. The spring force (50% stroke) of the level compensator should be higher than that of the inductive valve.

### Mounting parts

Item	Model	F - Female thread	Applicable suction cup
	M - Male thread		
Fitting for suction cup	PJS-M5M-SC3	-	SF15
	PJS-G1M-SF1	PJS-G1F-SF1	SF20, 25, 30
	PJS-G1M-SF2	PJS-G1F-SF2	SF40
	PJS-G2M-SF3	PJS-G2F-SF3	SF50
	PJS-G3M-SF3	PJS-G3F-SF3	SF50
	-	PJS-G2F-SF75	SF75
	-	PJS-G4F-SF110	SF110
	-	PJS-G4F-SF150	SF150
-	PJS-G4F-SF200	SF200	

# SU Series

## Universal Flat Suction Cup



### Features

- ◇ Standard flat lip
- ◇ Small inner volume
- ◇ Various sizes are available

### Advantages

- ◇ Suitable for handling most of workpieces with smooth and flat surface or slightly curved surface
- ◇ Short work cycle
- ◇ Suitable for workpieces with different sizes and shapes



### Applications

- ◇ Suitable for handling workpiece with smooth and flat surface or slightly curved surface, such as glass, wood plate, metal sheet, plastic plate, etc
- ◇ Suitable for handling automotive body parts

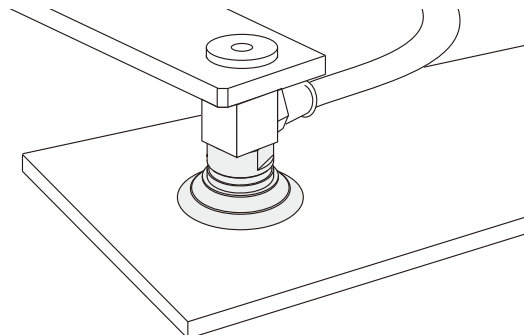

### Structure

- ◇ Suction cup with diameter  $\phi 6$ - $\phi 50$ mm and fitting are split structure design, wearing parts can be replaced separately
- ◇ For SU80, suction cup and fitting are one-piece structure

In same series, replacement suction cup and fitting can be combined on request

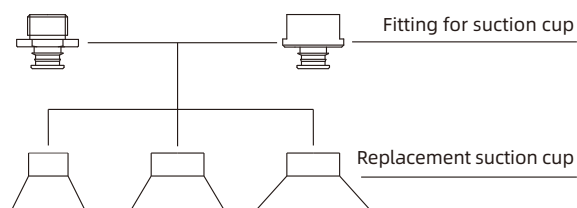

- SZ
- SPH
- SP3
- SUF
- SAN
- SAO
- SOFA
- STP
- SFT
- SFA
- SBT
- SBL
- SBLP
- SBS
- SFP
- SBP
- SXP
- SGP
- SBOF
- STC
- SFF
- SOB
- SOF
- SOG
- SFM
- SOM
- SBF
- SDM
- SFU
- SFK
- SHT
- SDL
- SFG
- SFGT
- SFD
- SB
- SBA
- SF
- SU**
- SP2F
- SPA
- SPD
- SPF
- SPC
- SPJ
- SPU
- SH
- SHB
- SBB
- SOP
- SNP

# SU Series

## Universal Flat Suction Cup

### How to order

## SU 20 N - G1F - EW

①      ②      ③      ④      ⑤

① Series	② Diameter	③ Material & Hardness	④ Connection thread	⑤ Special specification
SU	6 - φ6mm	25 - φ25mm N - NBR	<b>55</b> Nil - Suction cup only	M5M - M5×0.8 male thread Nil - Standard
	8 - φ8mm	30 - φ30mm S - Silicone	<b>50</b> G1F - G1/8 female thread	G1M - G1/8 male thread EW - With mesh filter
	10 - φ10mm	40 - φ40mm WS - White silicone	<b>50</b> G2F - G1/4 female thread	G2M - G1/4 male thread EH - With throttle valve
	15 - φ15mm	50 - φ50mm CS - Conductive silicone	<b>55</b> G3F - G3/8 female thread	G3M - G3/8 male thread
	20 - φ20mm	80 - φ80mm		

### Selection

Model	Connection thread	
	M - Male thread	F - Female thread
SU6□	SU6□-M5M	-
SU8□	SU8□-M5M	-
SU10□	SU10□-M5M	-
SU15□	SU15□-M5M	-
SU20□	SU20□-G1M(-EW/EH)	SU20□-G1F(-EW/EH)
SU25□	SU25□-G1M(-EW/EH)	SU25□-G1F(-EW/EH)
SU30□	SU30□-G1M(-EW/EH)	SU30□-G1F(-EW/EH)
SU40□	SU40□-G1M(-EW/EH)	SU40□-G1F(-EW/EH)
SU50□	SU50□-G2M(-EW/EH)    SU50□-G3M(-EW/EH)	SU50□-G2F(-EW/EH)    SU50□-G3F(-EW/EH)
SU80□	-	SU80□-G1F

### Technical parameters

Model	Pull-out force N	Inner volume cm <sup>3</sup>	Min.curve radius of workpiece mm	Weight g	Recommended hose dia. mm	MPQ pcs
SU6	2.1	<0.1	7.5	0.1	4	10
SU8	3.2	<0.1	10	0.2	4	10
SU10	4.7	<0.1	12	0.6	6	10
SU15	7.4	0.5	20	0.6	6	10
SU20	9.5	0.8	30	1.2	6	5
SU25	18	1.2	45	1.5	6	5
SU30	33	1.5	45	2.4	6	5
SU40	60	3	65	5.2	6	5
SU50	92	7	80	10.6	6	1
SU80	210	24	120	31	8	1

◇ Note: Testing vacuum level -60kPa, workpiece with smooth and clean surface. The data of pull-out force as above are figured out without considering safety factor. The data may be different according to different workpiece surfaces. Recommend the length of vacuum hose to be as short as possible, max 2m.

# SU Series

## Universal Flat Suction Cup

### Dimensions(mm) - Suction cup only

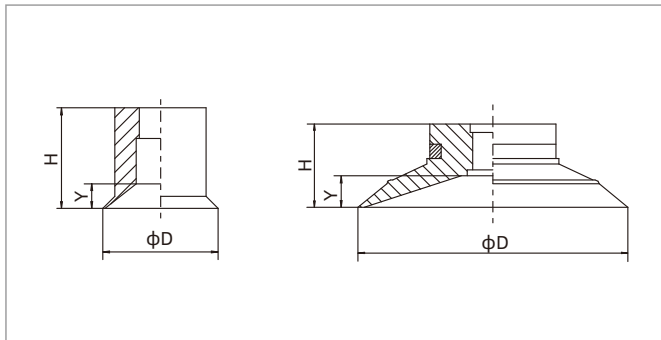

SU6-15

SU20-50

Model/Size	D	H	Y (Stroke)
SU6□	7	6.5	1.5
SU8□	9	7	2
SU10□	11	10.5	2
SF15□	16.5	11	3

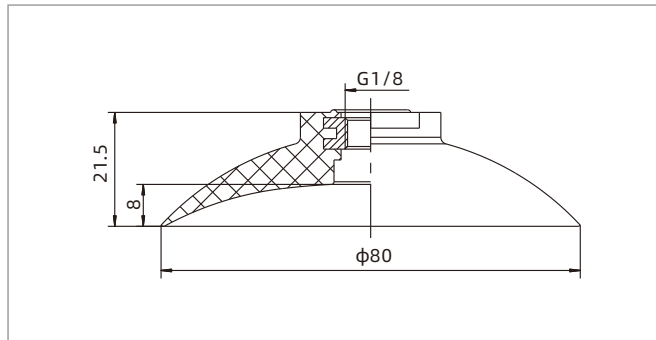

SU80

Model/Size	D	H	Y (Stroke)
SU20□	22	8	2.2
SU25□	27	9	2.9
SU30□	32	9.5	4.5
SU40□	42	13	5.2
SU50□	53	17.5	7

### Dimensions(mm) - Suction cup with fitting

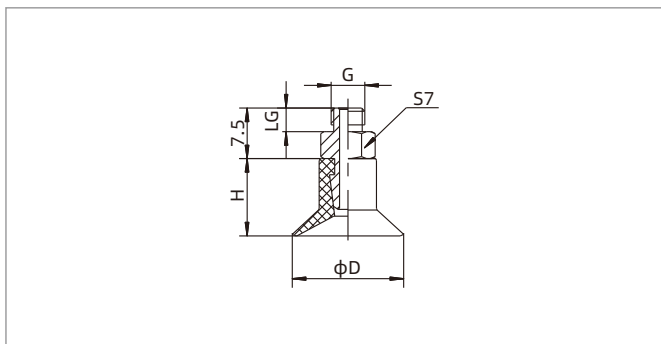

SU6-15 Male thread connection

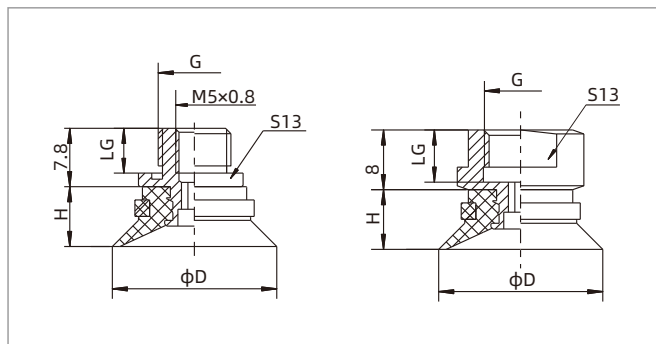

SU20-30 Male thread connection

SU20-30 Female thread connection

Model/Size	D	H	G	LG	h	S
SU6□-M5M	7	6.5	M5 × 0.8	3.5	7.5	7
SU8□-M5M	9	7	M5 × 0.8	3.5	7.5	7
SU10□-M5M	11	10.5	M5 × 0.8	3.5	7.5	7
SU15□-M5M	16.5	11	M5 × 0.8	3.5	7.5	7
SU20□-G1M	22	8	G1/8	6	7.8	13
SU20□-G1F	22	8	G1/8	7	8	13
SU25□-G1M	27	9	G1/8	6	7.8	13
SU25□-G1F	27	9	G1/8	7	8	13
SU30□-G1M	32	9.5	G1/8	6	7.8	13
SU30□-G1F	32	9.5	G1/8	7	8	13

- SZ
- SPH
- SP3
- SUF
- SAN
- SAO
- SOFA
- STP
- SFT
- SFA
- SBT
- SBL
- SBLP
- SBS
- SFP
- SBP
- SXP
- SGP
- SBOF
- STC
- SFF
- SOB
- SOF
- SOG
- SFM
- SOM
- SBF
- SDM
- SFU
- SFK
- SHT
- SDL
- SFG
- SFGT
- SFD
- SB
- SBA
- SF
- SU
- SP2F
- SPA
- SPD
- SPF
- SPC
- SPJ
- SPU
- SH
- SHB
- SBB
- SOP
- SNP

# SU Series

## Universal Flat Suction Cup

### Dimensions(mm) - Suction cup with fitting

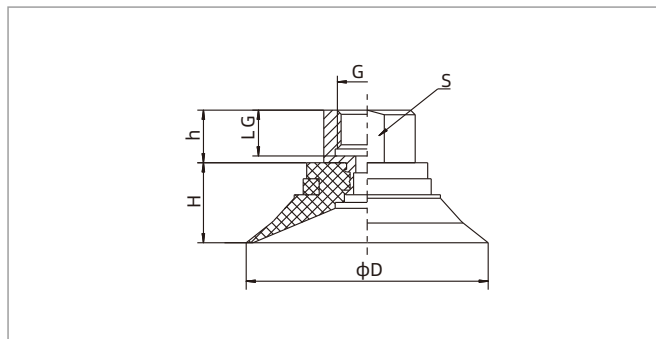
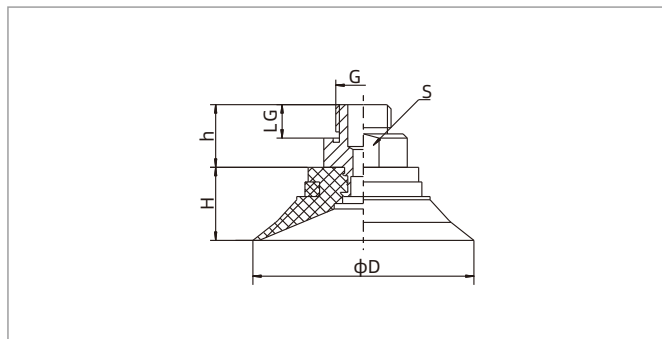

SU40-50 Male thread connection

SU40-50 Female thread connection

Model/Size	D	H	G	LG	h	s
SU40□-G1M	42	13	G1/8	6	12	17
SU40□-G1F	42	13	G1/8	7	10	17
SU50□-G2M	53	17.5	G1/4	9	17	24
SU50□-G2F	53	17.5	G1/4	10	13	24
SU50□-G3M	53	17.5	G3/8	10	18	24
SU50□-G3F	53	17.5	G3/8	11	13	24

◇ Note: The dimensional tolerance conforms to GBT3672.1-2002-1 M3 rubber product dimensional tolerance standard

### Mounting parts

Item	Model		Applicable suction cup
	M - Male thread	F - Female thread	
Fitting for suction cup	PJS-M5M-SC2	-	SU6,8
	PJS-M5M-SC3	-	SU10,15
	PJS-G1M-SF1	PJS-G1F-SF1	SU20,25,30
	PJS-G1M-SF2	PJS-G1F-SF2	SU40
	PJS-G2M-SF3	PJS-G2F-SF3	SU50
	PJS-G3M-SF3	PJS-G3F-SF3	SU50

# SP2F Series

## Thin Lip Flat Suction Cup

**AIRBEST**



PAPER ANTI-DEFORMATION



Suction Cup

### Features

- ◇ Thin lip, flat and short stroke
- ◇ With support structure at the bottom

### Advantages

- ◇ Good sealing for handling of thin and flat workpieces
- ◇ Prevents fold during handling of paper and thin film



### Applications

- ◇ Suitable for occasions that has high requirements for mark on product surface during handling, such as paper, plastic film, aluminum foil and copper foil

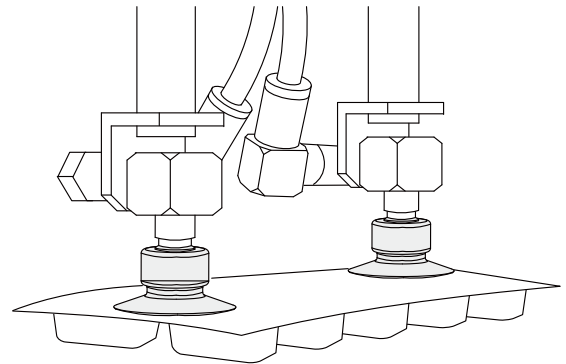

### Structure

- ◇ Split structure for easy replacement of wearing parts

In the same series, replacement suction cup and fitting can be combined as required

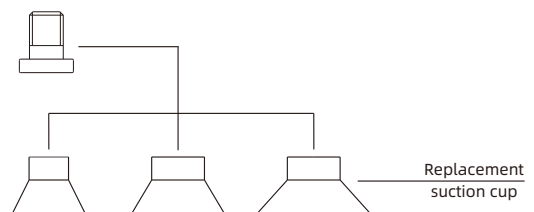

SZ  
SPH  
SP3  
SUF  
SAN  
SAO  
SOFA  
STP  
SFT  
SFA  
SBT  
SBL  
SBLP  
SBS  
SFP  
SBP  
SXP  
SGP  
SBOF  
STC  
SFF  
SOB  
SOF  
SOG  
SFM  
SOM  
SBF  
SDM  
SFU  
SFK  
SHT  
SDL  
SFG  
SFGT  
SFD  
SB  
SBA  
SF  
SU  
SP2F  
SPA  
SPD  
SPF  
SPC  
SPJ  
SPU  
SH  
SHB  
SBB  
SOP  
SNP

# SP2F Series

## Thin Lip Flat Suction Cup

### How to order

SP2F 10 N - M5M

①      ②      ③      ④

① Series	② Diameter	③ Material & Hardness	④ Connection thread
SP2F	10 - $\phi$ 10mm	N - NBR	Nil - Suction cup only
	15 - $\phi$ 15mm	WS - White silicone	M5M - M5x0.8 male thread
		CN - Conductive NBR	
		CS - Conductive silicone	

### Selection

Model	Connection thread
SP2F10□	SP2F10□-M5M
SP2F15□	SP2F15□-M5M

### Technical parameters

Model	Pull-out force N	Inner volume cm <sup>3</sup>	Weight g	Recommended hose dia. mm	MPQ pcs
SP2F10	3.2	<0.1	0.3	4	10
SP2F15	7.5	<0.1	0.36	4	10

◇ Note: Testing vacuum level -60kPa, workpiece with smooth and clean surface. The data of pull-out force as above are figured out without considering safety factor. The data may be different according to different workpiece surfaces. Recommend the length of vacuum hose to be as short as possible, max 2m.

# SP2F Series

## Thin Lip Flat Suction Cup

### Dimensions(mm) - Suction cup only

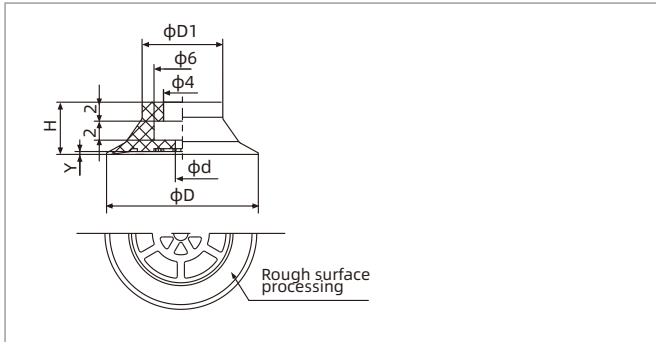

SP2F10-15

Model/Size	D	D1	H	d	Y
SP2F10□	11	8.5	5.5	1.5	0.3
SP2F15□	16	8.5	5.5	1.5	0.3

### Dimensions(mm) - Suction cup with fitting

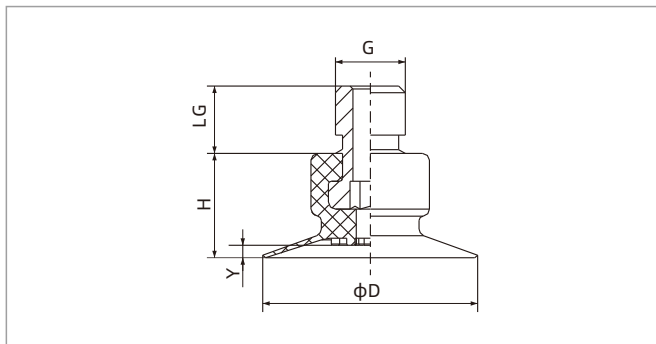

SP2F10-15 Male thread connection

Model/Size	D	H	G	LG	Y
SP2F10□-M5M	11	5.5	M5×0.8	5	0.3
SP2F15□-M5M	16	5.5	M5×0.8	5	0.3

### Mounting parts

Item	Model M - Male thread	Applicable suction cup
Fitting for suction cup	PJS-M5M-ST2	SP2F10、SP2F15

- SZ
- SPH
- SP3
- SUF
- SAN
- SAO
- SOFA
- STP
- SFT
- SFA
- SBT
- SBL
- SBLP
- SBS
- SFP
- SBP
- SXP
- SGP
- SBOF
- STC
- SFF
- SOB
- SOF
- SOG
- SFM
- SOM
- SBF
- SDM
- SFU
- SFK
- SHT
- SDL
- SFG
- SFGT
- SFD
- SB
- SBA
- SF
- SU
- SP2F
- SPA
- SPD
- SPF
- SPC
- SPJ
- SPU
- SH
- SHB
- SBB
- SOP
- SNP

# SP2F Series

## Suction Cup with Locking Fitting

### Structure

- ◇ Consisting of replacement suction cup and locking fitting
- ◇ Plug-in fitting for suction cup
- ◇ Vertical vacuum port, Pagoda fitting or one-touch fitting for connection, male thread for mounting
- ◇ Lateral vacuum port, Pagoda fitting for connection, female thread for mounting

In the same series, replacement suction cup and locking fitting can be combined as required

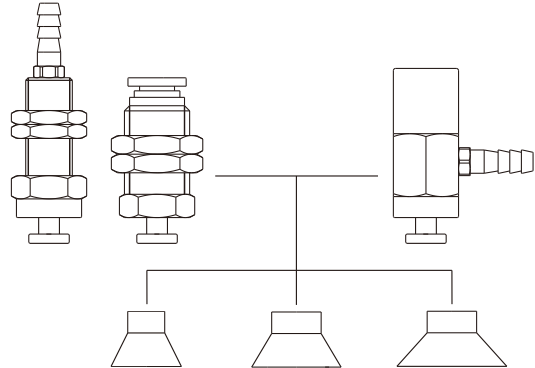

### How to order

**SP2F L B6 - M5M**  
 ①      ②      ③      ④

① Model	② Vacuum port direction	③ Vacuum port connection	④ Mounting thread
SP2F10□	Nil - Vertical direction	A4 - One-touch fitting $\phi 4$ hose	M4F - M4x0.7 female thread
	L - Lateral direction	A6 - One-touch fitting $\phi 6$ hose	M8M - M8x1 male thread
		B6 - Pagoda fitting $\phi 6$ hose	M12M - M12x1 male thread

◇ Please refer to page 294 for suction cup selection

### Selection

Model	Vacuum port direction Vertical - Pagoda fitting	Vertical - One-touch fitting	Lateral - Pagoda fitting
SP2F10□	SP2F10□-B6-M8M	SP2F10□-A4-M12M	SP2F10□-LB6-M4F
SP2F15□	SP2F15□-B6-M8M	SP2F15□-A4-M12M	SP2F15□-LB6-M4F

# SP2F Series

## Suction Cup with Locking Fitting

### Dimensions(mm)

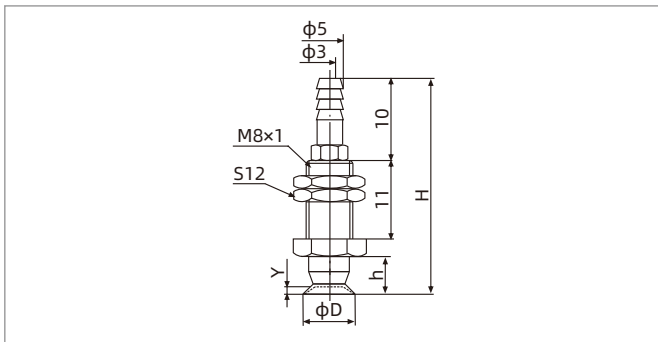

SP2F10-15 Vertical-Pagoda fitting

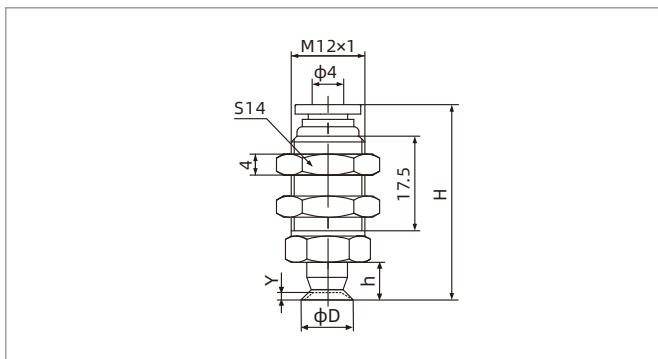

SP2F10-15 Vertical - One-touch fitting

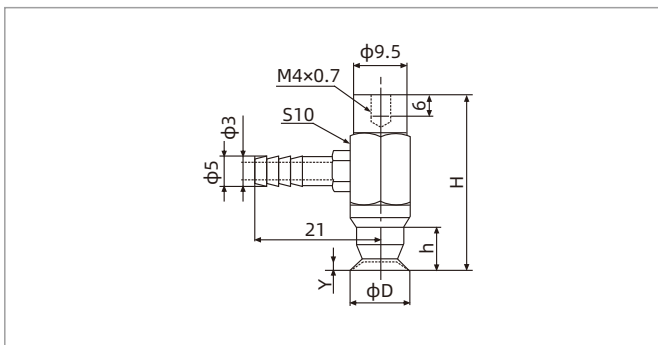

SP2F10-15 Lateral-Pagoda fitting

Model/Size	D	H	h	Y
SP2F10□-B6-M8M	11	29.5	5.5	0.3
SP2F15□-B6-M8M	16	29.5	5.5	0.3

Model/Size	D	H	h	Y
SP2F10□-A4-M12M	11	33	5.5	0.3
SP2F15□-A4-M12M	16	33	5.5	0.3

Model/Size	D	H	h	Y
SP2F10□-LB6-M4F	11	28	5.5	0.3
SP2F15□-LB6-M4F	16	28	5.5	0.3

- SZ
- SPH
- SP3
- SUF
- SAN
- SAO
- SOFA
- STP
- SFT
- SFA
- SBT
- SBL
- SBLP
- SBS
- SFP
- SBP
- SXP
- SGP
- SBOF
- STC
- SFF
- SOB
- SOF
- SOG
- SFM
- SOM
- SBF
- SDM
- SFU
- SFK
- SHT
- SDL
- SFG
- SFGT
- SFD
- SB
- SBA
- SF
- SU
- SP2F
- SPA
- SPD
- SPF
- SPC
- SPJ
- SPU
- SH
- SHB
- SBB
- SOP
- SNP

# SP2F Series

## Suction Cup with Level Compensator

### Structure

- ◇ Consisting of replacement suction cup(3) and level compensator
- ◇ Plug-in fitting for suction cup
- ◇ Vertical vacuum port(1), male thread for mounting
- ◇ Lateral vacuum port(2), male thread for mounting

In the same series, replacement suction cup and level compensator can be combined as required

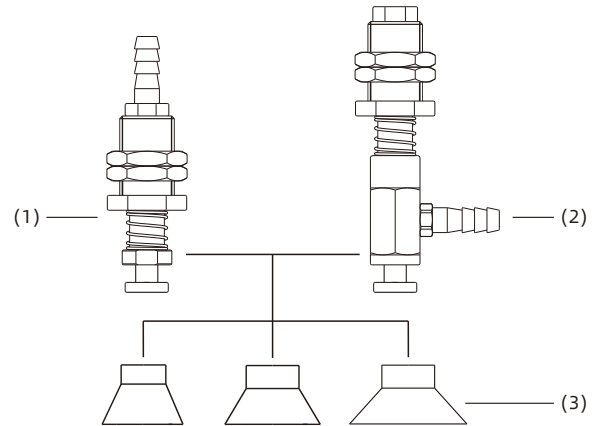

### How to order

**SP2F10N - F E 10 LB6 - M11**

①                      ②   ③   ④                      ⑤                      ⑥

① Model	② Level compensator type	③ Buffer type	④ Buffer stroke	⑤ Vacuum port connection	⑥ Mounting thread
<b>SP2F10N</b>	F - PSPF Series	E - External spring	4 10	B6 - Vertical, pagoda fitting φ6 hose LB6 - Lateral, pagoda fitting φ6 hose	M11 - M11×1

### Selection

Model	Vacuum port direction Vertical - Pagoda fitting		Lateral - Pagoda fitting	
	<b>SP2F10□</b>	SP2F10□-FE4B6-M11	SP2F10□-FE10B6-M11	SP2F10□-FE4LB6-M11
<b>SP2F15□</b>	SP2F15□-FE4B6-M11	SP2F15□-FE10B6-M11	SP2F15□-FE4LB6-M11	SP2F15□-FE10LB6-M11

# SP2F Series

## Suction Cup with Level Compensator

### Dimensions(mm)

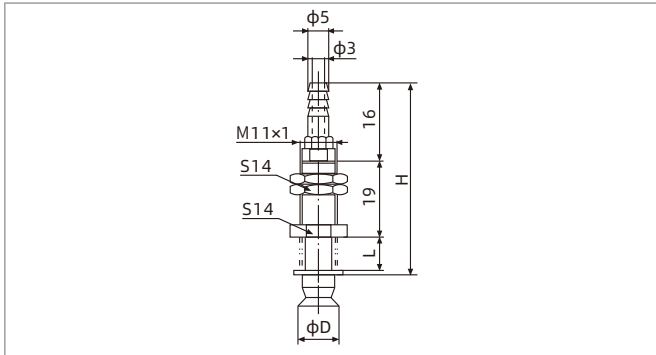

SP2F10-15 Vertical-Pagoda fitting

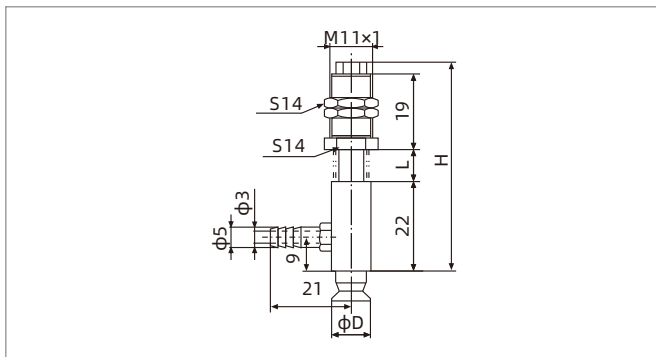

SP2F10-15 Lateral-Pagoda fitting

Model/Size	D	H	L	Buffer stroke
SP2F10□-FE4B6-M11	11	46	8	4
SP2F10□-FE10B6-M11	11	58	20	10
SP2F15□-FE4B6-M11	16	46	8	4
SP2F15□-FE10B6-M11	16	58	20	10

Model/Size	D	H	L	Buffer stroke
SP2F10□-FE4LB6-M11	11	52	8	4
SP2F10□-FE10LB6-M11	11	64	20	10
SP2F15□-FE4LB6-M11	16	52	8	4
SP2F15□-FE10LB6-M11	16	64	20	10

- SZ
- SPH
- SP3
- SUF
- SAN
- SAO
- SOFA
- STP
- SFT
- SFA
- SBT
- SBL
- SBLP
- SBS
- SFP
- SBP
- SXP
- SGP
- SBOF
- STC
- SFF
- SOB
- SOF
- SOG
- SFM
- SOM
- SBF
- SDM
- SFU
- SFK
- SHT
- SDL
- SFG
- SFGT
- SFD
- SB
- SBA
- SF
- SU
- SP2F
- SPA
- SPD
- SPF
- SPC
- SPJ
- SPU
- SH
- SHB
- SBB
- SOP
- SNP

# SPA Series

## Thin Lip Flat Suction Cup

**AIRBEST**



PAPER ANTI-DEFORMATION



### Features

- ◇ Thin lip, flat and short stroke
- ◇ With support structure at the bottom
- ◇ Available in various sizes

### Advantages

- ◇ Good sealing for handling of thin and flat workpieces
- ◇ Prevents fold during handling of paper and thin film
- ◇ Suitable for workpieces of various sizes and shapes



### Applications

- ◇ Suitable for occasions that has high requirements for mark on product surface during handling, such as paper, plastic film, aluminum foil and copper foil
- ◇ B type suction cup is flat and with thin lip, which is more suitable for handling thin workpieces that are easy to wrinkle, such as aluminum foil, copper foil

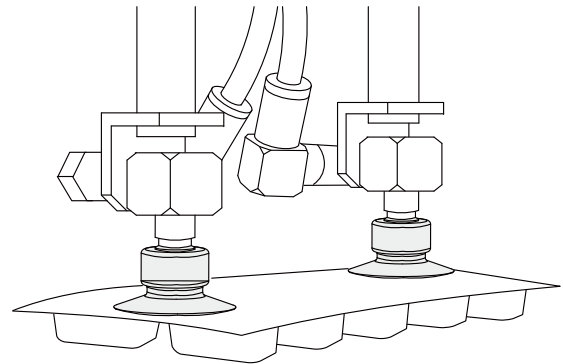

### Structure

- ◇ Split structure for easy replacement of wearing parts

In the same series, replacement suction cup and fitting can be combined as required

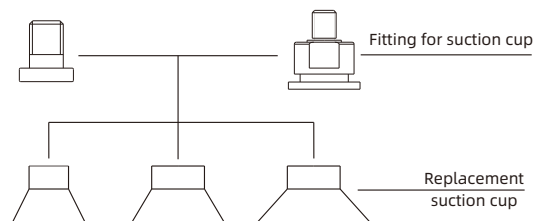

# SPA Series

## Thin Lip Flat Suction Cup

### How to order

## SPA 15 A N - M5M

① ② ③ ④ ⑤

① Series	② Diameter	③ Stroke	④ Material & Hardness	⑤ Connection thread
SPA	10 - $\phi$ 10mm	A	N - NBR <span style="background-color: black; color: white; padding: 0 2px;">50</span>	Nil - Suction cup only M5M - M5x0.8 male thread M6M - M6x1 male thread M8M - M8x1 male thread
	15 - $\phi$ 15mm	B	WS - White silicone <span style="border: 1px solid black; padding: 0 2px;">50</span>	
	20 - $\phi$ 20mm	D	CN - Conductive NBR <span style="background-color: black; color: white; padding: 0 2px;">55</span>	
	30 - $\phi$ 30mm		CS - Conductive silicone <span style="background-color: black; color: white; padding: 0 2px;">55</span>	
	40 - $\phi$ 40mm			
	50 - $\phi$ 50mm			

### Selection

Model	Connection thread M - Male thread	Model	Connection thread M - Male thread
SPA10A□	SPA10A□-M5M	SPA20B□	SPA20B□-M5M
SPA10B□	SPA10B□-M5M	SPA25A□	SPA25A□-M6M SPA25A□-M8M
SPA15A□	SPA15A□-M5M	SPA30A□	SPA30A□-M6M SPA30A□-M8M
SPA15B□	SPA15B□-M5M	SPA30B□	SPA30B□-M5M
SPA15D□	SPA15D□-M5M	SPA40A□	SPA40A□-M6M SPA40A□-M8M
SPA20A□	SPA20A□-M5M	SPA50A□	SPA50A□-M6M SPA50A□-M8M

### Technical parameters

Model	Pull-out force N	Inner volume cm <sup>3</sup>	Weight g	Recommended hose dia. mm	MPQ pcs
SPA10A	3.5	<0.1	0.3	4	10
SPA10B	3.5	<0.1	0.56	4	10
SPA15A	8	<0.1	0.28	4	10
SPA15B	8	<0.1	0.4	4	10
SPA15D	8	<0.1	0.28	4	10
SPA20A	15	0.3	0.8	4	5
SPA20B	15	<0.1	0.7	4	5
SPA25A	22	0.6	2.0	4	5
SPA30A	32	1.1	2.6	4	5
SPA30B	32	0.2	3.4	4	5
SPA40A	56	2.6	2.6	6	5
SPA50A	88	5.8	4.3	6	1

◇ Note: Testing vacuum level -60kPa, workpiece with smooth and clean surface. The data of pull-out force as above are figured out without considering safety factor. The data may be different according to different workpiece surfaces. Recommend the length of vacuum hose to be as short as possible, max 2m.

- SZ
- SPH
- SP3
- SUF
- SAN
- SAO
- SOFA
- STP
- SFT
- SFA
- SBT
- SBL
- SBLP
- SBS
- SFP
- SBP
- SXP
- SGP
- SBOF
- STC
- SFF
- SOB
- SOE
- SOG
- SFM
- SOM
- SBF
- SDM
- SFU
- SFK
- SHT
- SDL
- SFG
- SFGT
- SFD
- SB
- SBA
- SF
- SU
- SP2F
- SPA**
- SPD
- SPF
- SPC
- SPJ
- SPU
- SH
- SHB
- SBB
- SOP
- SNP

# SPA Series

## Thin Lip Flat Suction Cup

### Dimensions(mm) - Suction cup only

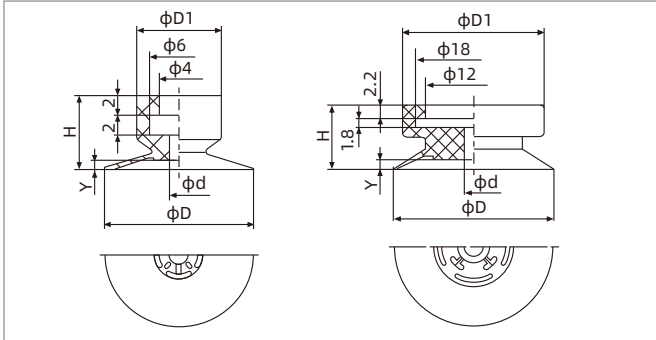

SPA10A-20A

SPA25A-50A

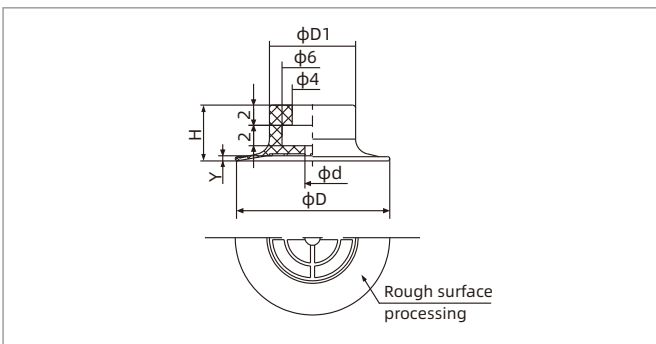

SPA15D

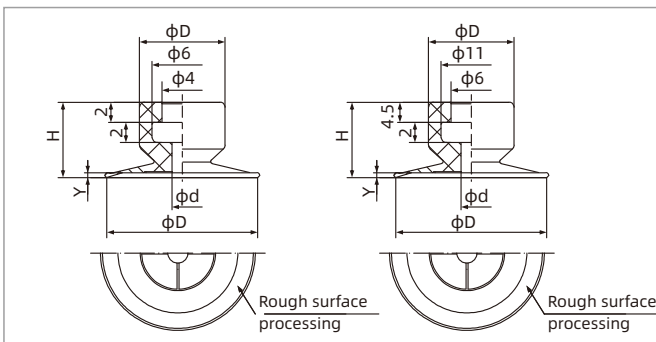

SPA10B-20B

SPA30B

Model/Size	D	D1	H	d	Y
SPA10A□	10	8.5	7.5	2	0.6
SPA15A□	15	8.5	7.5	2	0.9
SPA20A□	20	9	10	2	1.2
SPA25A□	25	22	10	3	1.5
SPA30A□	30	22	10	3	1.8
SPA40A□	40	22	10	3	2.4
SPA50A□	50	22	10	3	3

Model/Size	D	D1	H	d	Y
SPA15D□	15	8.5	5.5	1.5	0.5

Model/Size	D	D1	H	d	Y
SPA10B□	10	8.5	7.5	2	0.3
SPA15B□	15	8.5	7.5	2	0.5
SPA20B□	20	8.5	10	2	0.8
SPA30B□	30	15	11	3	0.3

### Dimensions(mm) - Suction cup with fitting

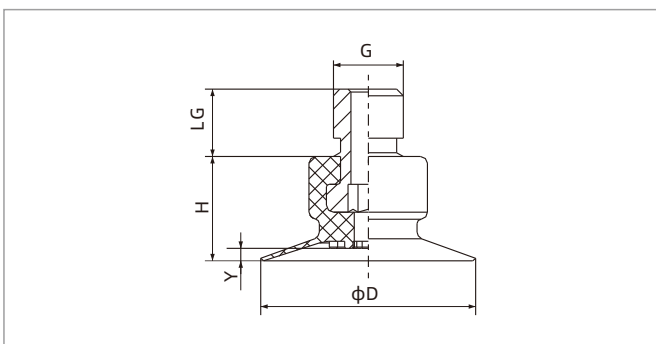

SPA10-30 Male thread connection

Model/Size	D	H	G	LG	Y
SPA10A□-M5M	10	7.5	M5×0.8	5	0.6
SPA10B□-M5M	10	7.5	M5×0.8	5	0.3
SPA15A□-M5M	15	7.5	M5×0.8	5	0.9
SPA15B□-M5M	15	7.5	M5×0.8	5	0.5
SPA15D□-M5M	15	5.5	M5×0.8	5	0.5
SPA20A□-M5M	20	10	M5×0.8	5	1.2
SPA20B□-M5M	20	10	M5×0.8	5	0.8
SPA30B□-M5M	30	11	M5×0.8	5	0.3

# SPA Series

## Thin Lip Flat Suction Cup

### Dimensions(mm) - Suction cup with fitting

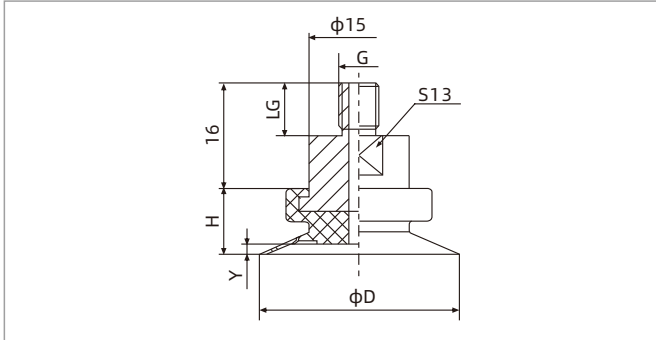

Model/size	D	H	G	LG	Y
SPA25A□-M6M	25	10	M6×1	8	1.5
SPA25A□-M8M	25	10	M8×1.25	8	1.5
SPA30A□-M6M	30	10	M6×1	8	1.8
SPA30A□-M8M	30	10	M8×1.25	8	1.8
SPA40A□-M6M	40	10	M6×1	8	2.4
SPA40A□-M8M	40	10	M8×1.25	8	2.4
SPA50A□-M6M	50	10	M6×1	8	3
SPA50A□-M8M	50	10	M8×1.25	8	3

SPA25A-50A

◇ Note: The dimensional tolerance conforms to the GBT 3672.1-2002-1 M3 rubber product dimensional tolerance standard

### Mounting parts

Item	Model M - Male thread	Applicable suction cup
Fitting for suction cup	PJS-M5M-ST2	SPA10A, 10B, 15A, 15B, 15D, 20A, 20B
	PJS-M5M-ST3	SPA30B
	PJS-M6M-ST7	SPA25A, 30A, 40A, 50A
	PJS-M8M-ST7	SPA25A, 30A, 40A, 50A

- SZ
- SPH
- SP3
- SUF
- SAN
- SAO
- SOFA
- STP
- SFT
- SFA
- SBT
- SBL
- SBLP
- SBS
- SFP
- SBP
- SXP
- SGP
- SBOF
- STC
- SFF
- SOB
- SOF
- SOG
- SFM
- SOM
- SBF
- SDM
- SFU
- SFK
- SHT
- SDL
- SFG
- SFGT
- SFD
- SB
- SBA
- SF
- SU
- SP2F
- SPA**
- SPD
- SPF
- SPC
- SPJ
- SPU
- SH
- SHB
- SBB
- SOP
- SNP

# SPA Series

## Suction Cup with Locking Fitting

### Structure

- ◇ Consisting of replacement suction cup and locking fitting
- ◇ Plug-in fitting for suction cup
- ◇ Vertical vacuum port, Pagoda fitting or one-touch fitting for connection, male thread for mounting
- ◇ Lateral vacuum port, Pagoda fitting for connection, female thread for mounting

In the same series, replacement suction cup and locking fitting can be combined as required

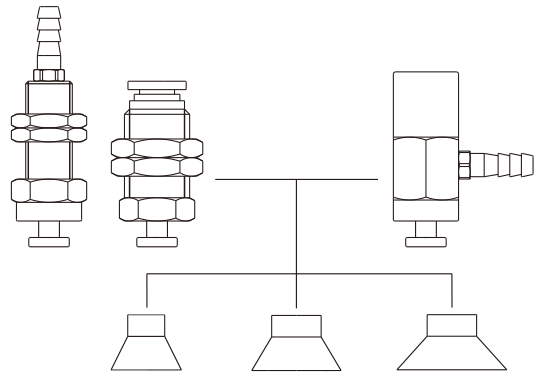

### How to order

**SPA10AN - L B6 - M4F**

①                      ②   ③                      ④

① Model	② Vacuum port direction	③ Vacuum port connection	④ Mounting thread
<b>SPA10AN</b>	Nil - Vertical direction	A4 - One-touch fitting $\phi$ 4 hose	M4F - M4×0.7 female thread
	L - Lateral direction	A6 - One-touch fitting $\phi$ 6 hose B6 - Pagoda fitting $\phi$ 6 hose	M6F - M6×1 female thread M8M - M8×1 male thread M10M - M10×1 male thread M12M - M12×1 male thread M14M - M14×1 male thread

◇ Please refer to page 301 for suction cup selection

### Selection

Model	Vacuum port direction Vertical-Pagoda fitting	Vertical-One-touch fitting	Lateral-Pagoda fitting
SPA10A□	SPA10A□-B6-M8M	SPA10A□-A4-M12M	SPA10A□-LB6-M4F
SPA10B□	SPA10B□-B6-M8M	SPA10B□-A4-M12M	SPA10B□-LB6-M4F
SPA15A□	SPA15A□-B6-M8M	SPA15A□-A4-M12M	SPA15A□-LB6-M4F
SPA15B□	SPA15B□-B6-M8M	SPA15B□-A4-M12M	SPA15B□-LB6-M4F
SPA15D□	SPA15D□-B6-M8M	SPA15D□-A4-M12M	SPA15D□-LB6-M4F
SPA20A□	SPA20A□-B6-M8M	SPA20A□-A4-M12M	SPA20A□-LB6-M4F
SPA20B□	SPA20B□-B6-M8M	SPA20B□-A4-M12M	SPA20B□-LB6-M4F
SPA25A□	SPA25A□-B6-M10M	SPA25A□-A6-M14M	SPA25A□-LB6-M6F
SPA30A□	SPA30A□-B6-M10M	SPA30A□-A6-M14M	SPA30A□-LB6-M6F
SPA30B□	SPA30B□-B6-M10M	SPA30B□-A6-M14M	SPA30B□-LB6-M6F
SPA40A□	SPA40A□-B6-M10M	SPA40A□-A6-M14M	SPA40A□-LB6-M6F
SPA50A□	SPA50A□-B6-M10M	SPA50A□-A6-M14M	SPA50A□-LB6-M6F

# SPA Series

## Suction Cup with Locking Fitting

### Dimensions(mm)

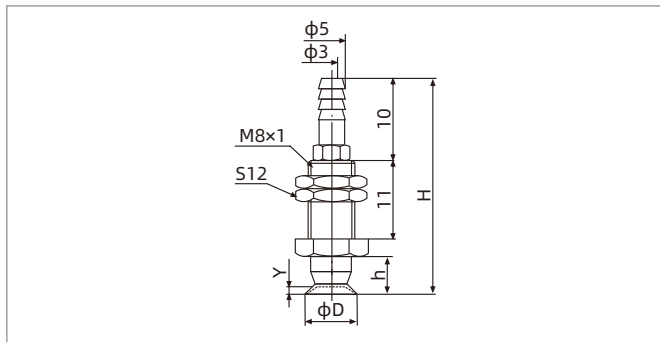

SPA10-20 Vertical-Pagoda fitting

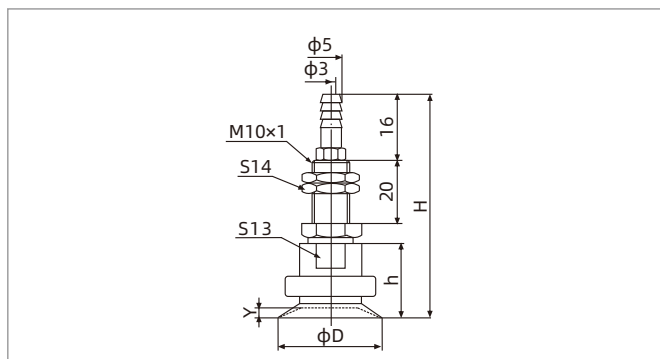

SPA25-50 Vertical-Pagoda fitting

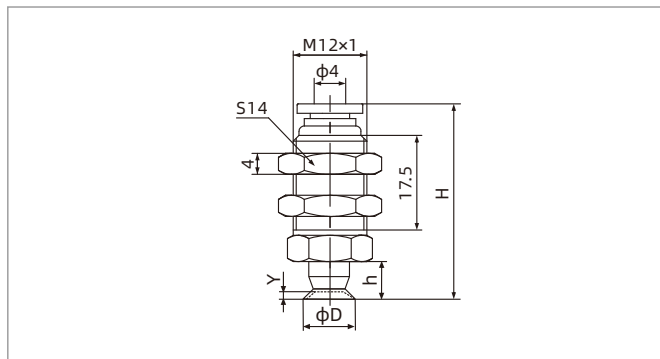

SPA10-20 Vertical-One-touch fitting

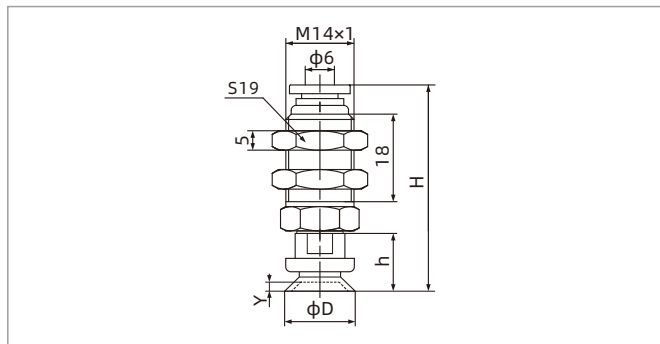

SPA25-50 Vertical-One-touch fitting

Model/Size	D	H	h	Y
SPA10A□-B6-M8M	10	31.5	7.5	0.6
SPA10B□-B6-M8M	10	31.5	7.5	0.3
SPA15A□-B6-M8M	15	31.5	7.5	0.9
SPA15B□-B6-M8M	15	31.5	7.5	0.5
SPA15D□-B6-M8M	15	29.5	5.5	0.5
SPA20A□-B6-M8M	20	34	10	12
SPA20B□-B6-M8M	20	34	10	0.8

Model/Size	D	H	h	Y
SPA25A□-B6-M10M	25	66	18	1.5
SPA30A□-B6-M10M	30	66	18	1.8
SPA30B□-B6-M10M	30	59	11	1.5
SPA40A□-B6-M10M	40	66	18	2.4
SPA50A□-B6-M10M	50	66	18	3

Model/Size	D	H	h	Y
SPA10A□-A4-M12M	10	35	7.5	0.6
SPA10B□-A4-M12M	10	35	7.5	0.3
SPA15A□-A4-M12M	15	35	7.5	0.9
SPA15B□-A4-M12M	15	35	7.5	0.5
SPA15D□-A4-M12M	15	33	5.5	0.5
SPA20A□-A4-M12M	20	37.5	10	12
SPA20B□-A4-M12M	20	37.5	10	0.8

Model/Size	D	H	h	Y
SPA25A□-A6-M14M	25	48	18	1.5
SPA30A□-A6-M14M	30	48	18	1.8
SPA30B□-A6-M14M	30	40	11	1.5
SPA40A□-A6-M14M	40	48	18	2.4
SPA50A□-A6-M14M	50	48	18	3

- SZ
- SPH
- SP3
- SUF
- SAN
- SAO
- SOFA
- STP
- SFT
- SFA
- SBT
- SBL
- SBLP
- SBS
- SFP
- SBP
- SXP
- SGP
- SBOF
- STC
- SFF
- SOB
- SOF
- SOG
- SFM
- SOM
- SBF
- SDM
- SFU
- SFK
- SHT
- SDL
- SFG
- SFGT
- SFD
- SB
- SBA
- SF
- SU
- SP2F
- SPA
- SPD
- SPF
- SPC
- SPJ
- SPU
- SH
- SHB
- SBB
- SOP
- SNP

# SPA Series

## Suction Cup with Locking Fitting

### Dimensions(mm)

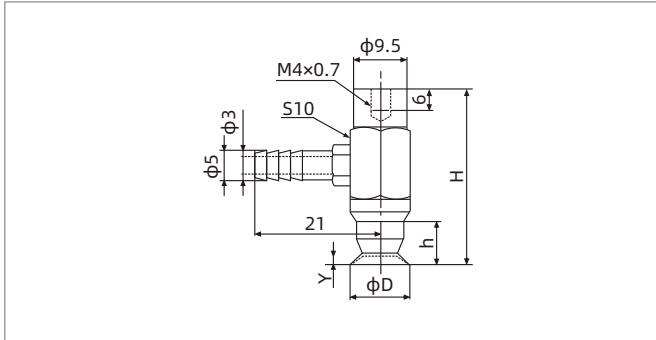

SPA10-20 Lateral-Pagoda fitting

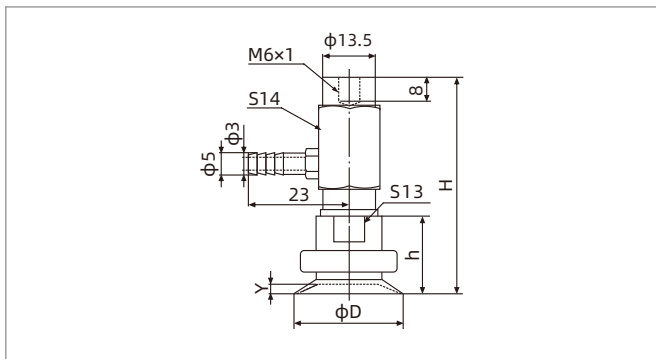

SPA25-50 Lateral-Pagoda fitting

Model/Size	D	H	h	Y
SPA10A□-LB6-M4F	10	30	7.5	0.6
SPA10B□-LB6-M4F	10	30	7.5	0.3
SPA15A□-LB6-M4F	15	30	7.5	0.9
SPA15B□-LB6-M4F	15	30	7.5	0.5
SPA15D□-LB6-M4F	15	28	5.5	0.5
SPA20A□-LB6-M4F	20	32.5	10	12
SPA20B□-LB6-M4F	20	32.5	10	0.8

Model/Size	D	H	h	Y
SPA25A□-LB6-M6F	25	51.5	18	1.5
SPA30A□-LB6-M6F	30	51.5	18	1.8
SPA30B□-LB6-M6F	30	44.5	11	1.5
SPA40A□-LB6-M6F	40	51.5	18	2.4
SPA50A□-LB6-M6F	50	51.5	18	3

# SPA Series

## Suction Cup with Level Compensator

### Structure

- ◇ Consisting of replacement suction cup(3) and level compensator
- ◇ Plug-in fitting for suction cup
- ◇ Vertical vacuum port(1), male thread for mounting
- ◇ Lateral vacuum port(2), male thread for mounting

In the same series, replacement suction cup and level compensator can be combined as required

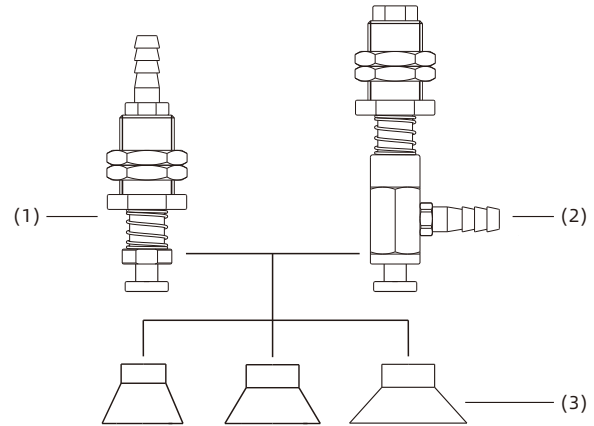

### How to order

## SPA10AN - F E 10 LB6 - M11

①                      ②    ③    ④                      ⑤                      ⑥

① Model	② Level compensator type	③ Buffer type	④ Buffer stroke	⑤ Vacuum port connection	⑥ Mounting thread
SPA10AN	F - PSPF Series	E - External spring	4    6	B6 - Vertical, pagoda fitting φ6 hose	M11 - M11×1
			10 15	LB6 - Lateral, pagoda fitting φ6 hose	M14 - M14×1

### Selection

Model	Vacuum port direction Vertical - Pagoda fitting		Lateral - Pagoda fitting	
SPA10A□	SPA10A□-FE4B6-M11	SPA10A□-FE10B6-M11	SPA10A□-FE4LB6-M11	SPA10A□-FE10LB6-M11
SPA10B□	SPA10B□-FE4B6-M11	SPA10B□-FE10B6-M11	SPA10B□-FE4LB6-M11	SPA10B□-FE10LB6-M11
SPA15A□	SPA15A□-FE4B6-M11	SPA15A□-FE10B6-M11	SPA15A□-FE4LB6-M11	SPA15A□-FE10LB6-M11
SPA15B□	SPA15B□-FE4B6-M11	SPA15B□-FE10B6-M11	SPA15B□-FE4LB6-M11	SPA15B□-FE10LB6-M11
SPA15D□	SPA15D□-FE4B6-M11	SPA15D□-FE10B6-M11	SPA15D□-FE4LB6-M11	SPA15D□-FE10LB6-M11
SPA20A□	SPA20A□-FE4B6-M11	SPA20A□-FE10B6-M11	SPA20A□-FE4LB6-M11	SPA20A□-FE10LB6-M11
SPA20B□	SPA20B□-FE4B6-M11	SPA20B□-FE10B6-M11	SPA20B□-FE4LB6-M11	SPA20B□-FE10LB6-M11
SPA25A□	SPA25A□-FE6B6-M14	SPA25A□-FE15B6-M14	SPA25A□-FE6LB6-M14	SPA25A□-FE15LB6-M14
SPA30A□	SPA30A□-FE6B6-M14	SPA30A□-FE15B6-M14	SPA30A□-FE6LB6-M14	SPA30A□-FE15LB6-M14
SPA30B□	SPA30B□-FE6B6-M14	SPA30B□-FE15B6-M14	SPA30B□-FE6LB6-M14	SPA30B□-FE15LB6-M14
SPA40A□	SPA40A□-FE6B6-M14	SPA40A□-FE15B6-M14	SPA40A□-FE6LB6-M14	SPA40A□-FE15LB6-M14
SPA50A□	SPA50A□-FE6B6-M14	SPA50A□-FE15B6-M14	SPA50A□-FE6LB6-M14	SPA50A□-FE15LB6-M14

- SZ
- SPH
- SP3
- SUF
- SAN
- SAO
- SOFA
- STP
- SFT
- SFA
- SBT
- SBL
- SBLP
- SBS
- SFP
- SBP
- SXP
- SGP
- SBOF
- STC
- SFF
- SOB
- SOE
- SOG
- SFM
- SOM
- SBF
- SDM
- SFU
- SFK
- SHT
- SDL
- SFG
- SFGT
- SFD
- SB
- SBA
- SF
- SU
- SP2F
- SPA
- SPD
- SPF
- SPC
- SPJ
- SPU
- SH
- SHB
- SBB
- SOP
- SNP

# SPA Series

## Suction Cup with Level Compensator

### Dimensions(mm)

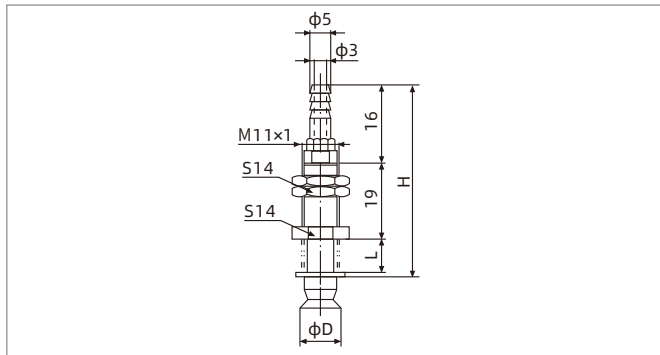

SPA10-20 Vertical-Pagoda fitting

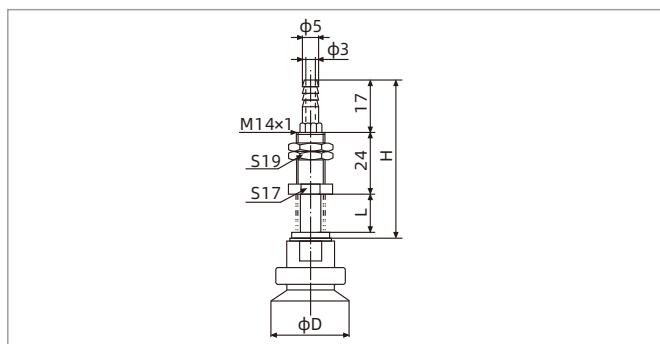

SPA25-50 Vertical-Pagoda fitting

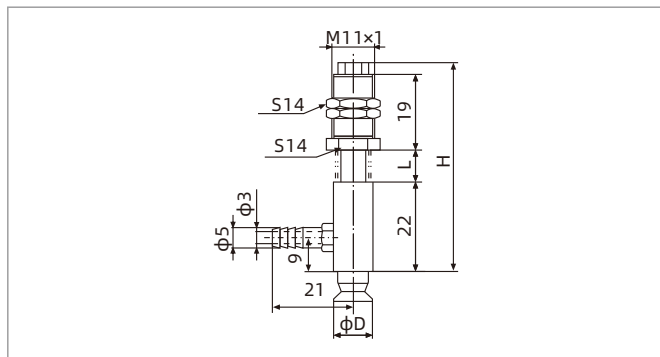

SPA10-20 Lateral-Pagoda fitting

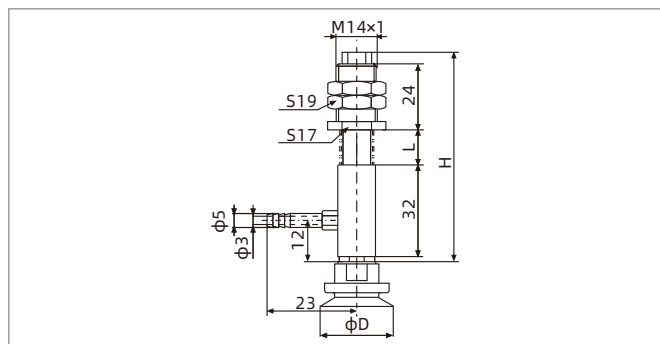

SPA25-50 Lateral-Pagoda fitting

Model/Size	D	H	L	Buffer stroke
SPA10□□-FE4B6-M11	10	46	8	4
SPA10□□-FE10B6-M11	10	58	20	10
SPA15□□-FE4B6-M11	15	46	8	4
SPA15□□-FE10B6-M11	15	58	20	10
SPA20□□-FE4B6-M11	20	46	8	4
SPA20□□-FE10B6-M11	20	58	20	10

Model/Size	D	H	L	Buffer stroke
SPA25□□-FE6B6-M14	25	57	13	6
SPA25□□-FE15B6-M14	25	74	30	15
SPA30□□-FE6B6-M14	30	57	13	6
SPA30□□-FE15B6-M14	30	74	30	15
SPA40□□-FE6B6-M14	40	57	13	6
SPA40□□-FE15B6-M14	40	74	30	15
SPA50□□-FE6B6-M14	50	57	13	6
SPA50□□-FE15B6-M14	50	74	30	15

Model/Size	D	H	L	Buffer stroke
SPA10□□-FE4LB6-M11	10	52	8	4
SPA10□□-FE10LB6-M11	10	64	20	10
SPA15□□-FE4LB6-M11	15	52	8	4
SPA15□□-FE10LB6-M11	15	64	20	10
SPA20□□-FE4LB6-M11	20	52	8	4
SPA20□□-FE10LB6-M11	20	64	20	10

Model/Size	D	H	L	Buffer stroke
SPA25□□-FE6LB6-M14	25	73	13	6
SPA25□□-FE15LB6-M14	25	90	30	15
SPA30□□-FE6LB6-M14	30	73	13	6
SPA30□□-FE15LB6-M14	30	90	30	15
SPA40□□-FE6LB6-M14	40	73	13	6
SPA40□□-FE15LB6-M14	40	90	30	15
SPA50□□-FE6LB6-M14	50	73	13	6
SPA50□□-FE15LB6-M14	50	90	30	15

# SPD Series

## Thin Lip Flat Suction Cup



PAPER



### Features

- ◇ Thin lip

### Advantages

- ◇ Fits thin film workpieces closely



### Applications

- ◇ Most suitable for the handling of copy paper, PVC and other film materials

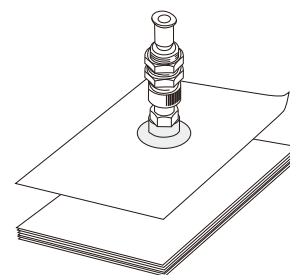

### How to order

**SPD 15 N - M5M**  
 ①      ②      ③      ④

① Series	② Diameter	③ Material & Hardness		④ Connection thread
SPD	10 - $\phi$ 10mm	N - NBR	<b>50</b>	Nil - Suction cup only
	15 - $\phi$ 15mm	WS - White silicone	<b>50</b>	M5M - M5x0.8 male thread

### Selection

Model	M5M
SPD10	SPD10□-M5M
SPD15	SPD15□-M5M

### Technical parameters

Model	Pull-out force (N)	Inner volume $\text{cm}^3$	Weight g	Recommended hose Dia. mm	MPQ pcs
SPD10	3.5	< 0.1	0.2	4	10
SPD15	7.5	< 0.1	0.3	4	10

◇ Note: Testing vacuum level -60kPa, workpiece with smooth and clean surface. The data of pull-out force as above are figured out without considering safety factor. The data may be different according to different working condition

- SZ
- SPH
- SP3
- SUF
- SAN
- SAO
- SOFA
- STP
- SFT
- SFA
- SBT
- SBL
- SBLP
- SBS
- SFP
- SBP
- SXP
- SGP
- SBOF
- STC
- SFF
- SOB
- SOF
- SOG
- SFM
- SOM
- SBF
- SDM
- SFU
- SFK
- SHT
- SDL
- SFG
- SFGT
- SFD
- SB
- SBA
- SF
- SU
- SP2F
- SPA
- SPD**
- SPF
- SPC
- SPJ
- SPU
- SH
- SHB
- SBB
- SOP
- SNP

# SPD Series

## Thin Lip Flat Suction Cup

### Dimensions (mm) - Suction cup only

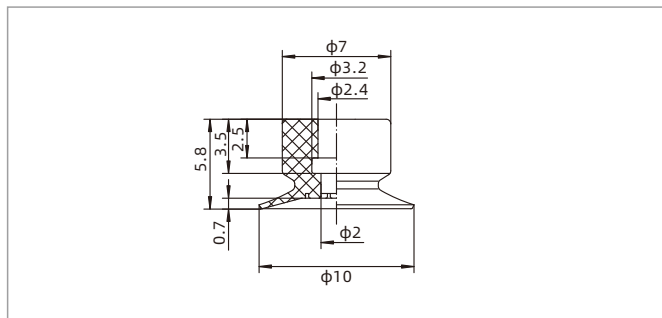

SPD10

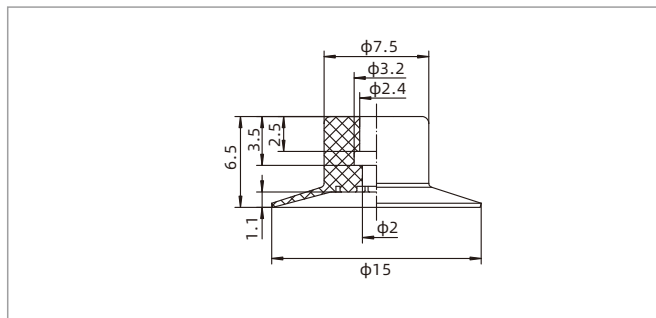

SPD15

### Dimensions mm - Male thread fitting

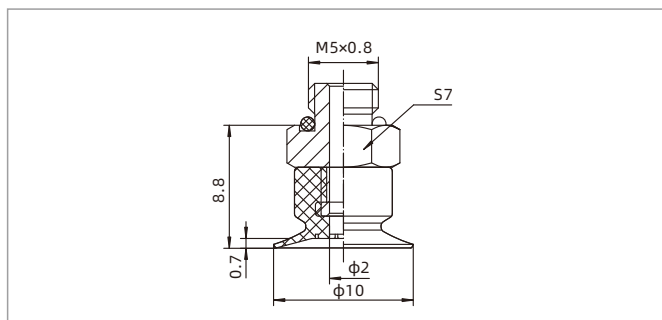

SPD10-M5M

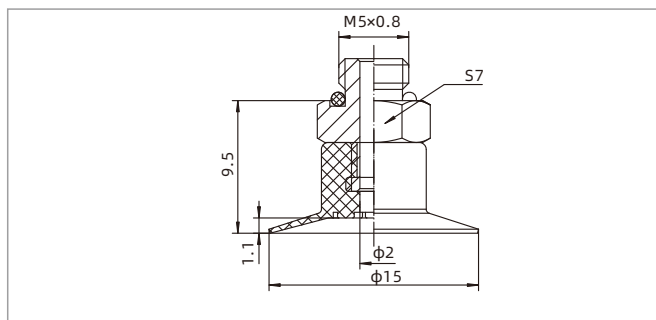

SPD15-M5M

◇ Note: The dimensional tolerance conforms to GBT3672.1-2002-1 M3 rubber product dimensional tolerance standard

# SPF Series

## Flat Suction Cup



### Features

- ◇ With support structure at the bottom
- ◇ Optimal design
- ◇ Small inner volume
- ◇ Available in various sizes

### Advantages

- ◇ Be able to prevent permanent deformation of workpieces
- ◇ Small size, large suction force
- ◇ Short working cycle
- ◇ Suitable for workpieces of various sizes and shapes



### Applications

- ◇ Handling of flat workpieces with smooth or slightly rough surface such as wood, metal plate, plywood and plastic plate
- ◇ Suitable for handling electronic components, conductive material can effectively prevent electrostatic damage to electronic components

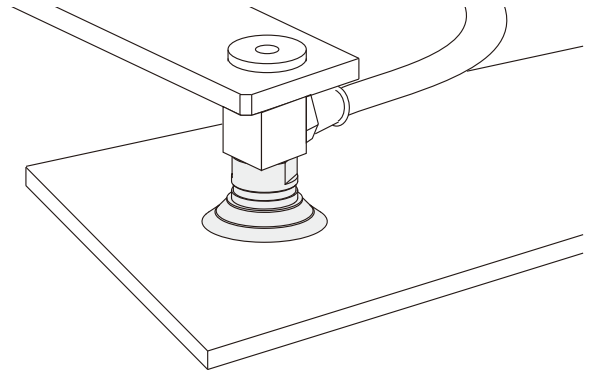

### Structure

- ◇ Suction cups with diameter less than 50mm adopt split structure for easy replacement of wearing parts
- ◇ One-piece structure for suction cup with diameter 60mm-200mm

In the same series, replacement suction cup and fitting can be combined as required

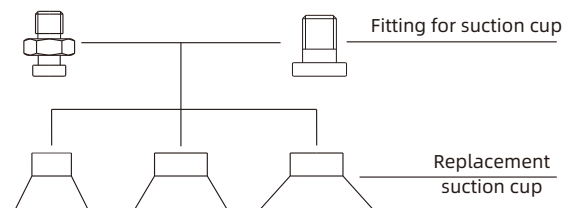

- SZ
- SPH
- SP3
- SUF
- SAN
- SAO
- SOFA
- STP
- SFT
- SFA
- SBT
- SBL
- SBLP
- SBS
- SFP
- SBP
- SXP
- SGP
- SBOF
- STC
- SFF
- SOB
- SOE
- SOG
- SFM
- SOM
- SBF
- SDM
- SFU
- SFK
- SHT
- SDL
- SFG
- SFGT
- SFD
- SB
- SBA
- SF
- SU
- SP2F
- SPA
- SPD**
- SPF**
- SPC
- SPJ
- SPU
- SH
- SHB
- SBB
- SOP
- SNP

# SPF Series

## Flat Suction Cup

### How to order

## SPF 15 N - M5M

①      ②      ③      ④

① Series	② Diameter	③ Material & Hardness	④ Connection thread	
SPF	2 - $\phi$ 2mm	35 - $\phi$ 35mm	N - NBR <span style="background-color: black; color: white; padding: 0 2px;">55</span>	Nil - Suction cup only
	3.5 - $\phi$ 3.5mm	40 - $\phi$ 40mm	WS - White silicone <span style="border: 1px solid black; padding: 0 2px;">50</span>	M3M - M3×0.5 male thread
	5 - $\phi$ 5mm	50 - $\phi$ 50mm	CN - Conductive NBR <span style="background-color: black; color: white; padding: 0 2px;">55</span>	M5M - M5×0.8 male thread
	6 - $\phi$ 6mm	60 - $\phi$ 60mm	CS - Conductive silicone <span style="background-color: black; color: white; padding: 0 2px;">55</span>	M8M - M8×1.25 male thread
	8 - $\phi$ 8mm	80 - $\phi$ 80mm		M10F - M10×1.25 female thread
	10 - $\phi$ 10mm	95 - $\phi$ 95mm		
	15 - $\phi$ 15mm	120 - $\phi$ 120mm		
	20 - $\phi$ 20mm	150 - $\phi$ 150mm		
	25 - $\phi$ 25mm	200 - $\phi$ 200mm		
	30 - $\phi$ 30mm			

### Selection

Model	Connection thread M - Male thread	Model	Connection thread M - Male thread
SPF2□	SPF2□-M3M	SPF25□	SPF25□-M5M
SPF3.5□	SPF3.5□-M3M	SPF30□	SPF30□-M5M
SPF5□	SPF5□-M5M	SPF35□	SPF35□-M5M
SPF6□	SPF6□-M5M	SPF40□	SPF40□-M5M
SPF8□	SPF8□-M5M	SPF50□	SPF50□-M8M
SPF10□	SPF10□-M5M	SPF60□-M10F	-
SPF15□	SPF15□-M5M	SPF80□-M10F	-
SPF20□	SPF20□-M5M	SPF95□-M10F	-

### Technical parameters

Model	Pull-out force N	Inner volume cm <sup>3</sup>	Weight g	Recommended hose dia. mm	MPQ pcs	Model	Pull-out force N	Inner volume cm <sup>3</sup>	Weight g	Recommended hose dia. mm	MPQ pcs
SPF2	0.15	<0.1	0.1	4	10	SPF35	43	2.4	6.6	6	5
SPF3.5	0.4	<0.1	0.1	4	10	SPF40	60	3.4	8.4	6	5
SPF5	0.9	<0.1	0.2	4	10	SPF50	92	5.7	10.4	8	1
SPF6	1.2	<0.1	0.2	4	10	SPF60	127	11	23.2	8	1
SPF8	2.2	<0.1	0.2	4	10	SPF80	226	25.3	48.2	8	1
SPF10	3.5	<0.1	0.3	4	10	SPF95	319	38	70.3	10	1
SPF15	8	0.2	0.4	6	10	SPF120	510	81	159.5	10	1
SPF20	15	0.5	1.6	6	5	SPF150	800	171	322.4	12	1
SPF25	24	1.1	2.5	6	5	SPF200	1,410	364	521.5	12	1
SPF30	32	1	3.3	6	5						

# SPF Series

## Flat Suction Cup

### Dimensions(mm) - Suction cup only

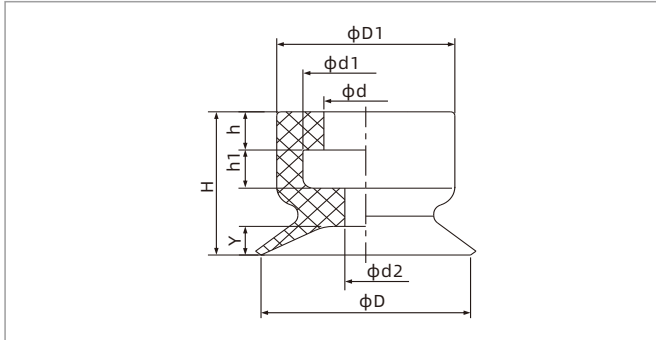

SPF2-15

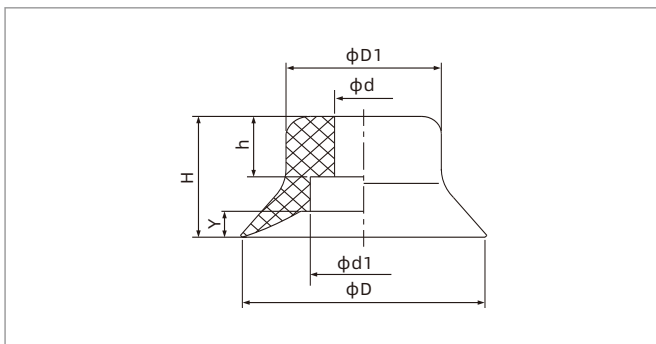

SPF20-50

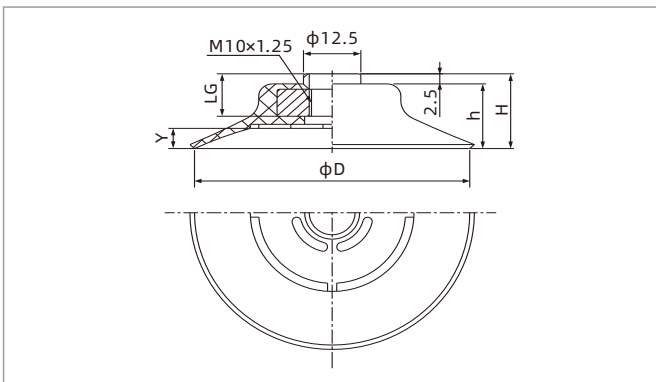

SPF60-95

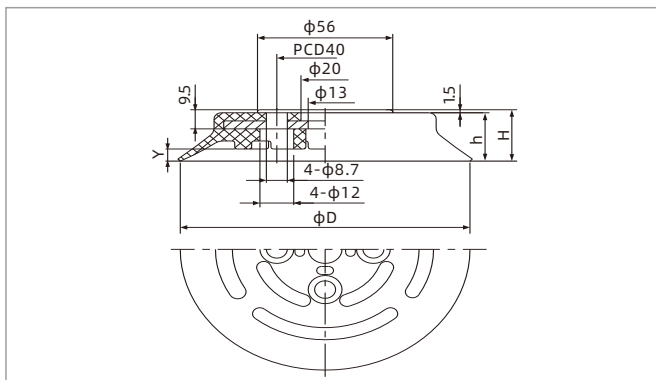

SPF120-200

Model/Size	D	H	D1	d	h	d1	h1	d2	Y
SPF2□	2	4	4	2	1.5	3	1	1.2	0.5
SPF3.5□	3.5	4	4	2	1.5	3	1	1.2	0.5
SPF5□	5	6.5	7.5	4	2	6	2	1.4	0.8
SPF6□	6	6.5	7.5	4	2	6	2	2	0.8
SPF8□	8	7	8	4	2	6	2	2	1.2
SPF10□	10	7.5	8.5	4	2	6	2	2	1.5
SPF15□	15	8	9	4	2	6	2	2	1.9

Model/Size	D	H	D1	d	h	d1	Y
SPF20□	20	10	15	6	4.5	10.8	2.3
SPF25□	25	14	16	6	7	11	3
SPF30□	29	12	14	6	7	11	2
SPF35□	35	14	21	6	7	11	3
SPF40□	40	14	24	6	7	11	3.5
SPF50□	50	15	27	8	7	20	4

Model/Size	D	H	h	LG	Y
SPF60□-M10F	60	18.5	16	10.5	5
SPF80□-M10F	80	20.5	18	11.5	6
SPF95□-M10F	95	21	18.5	11	6

Model/size	D	H	h	Y
SPF120□	120	25.5	24	6
SPF150□	150	32.5	31	9
SPF200□	200	37.5	36	13

◇ Note: The dimensional tolerance conforms to GBT 3672.1-2002-1 M3 rubber product dimensional tolerance standard

- SZ
- SPH
- SP3
- SUF
- SAN
- SAO
- SOFA
- STP
- SFT
- SFA
- SBT
- SBL
- SBLP
- SBS
- SFP
- SBP
- SXP
- SGP
- SBOF
- STC
- SFF
- SOB
- SOF
- SOG
- SFM
- SOM
- SBF
- SDM
- SFU
- SFK
- SHT
- SDL
- SFG
- SFGT
- SFD
- SB
- SBA
- SF
- SU
- SP2F
- SPA
- SPD
- SPF**
- SPC
- SPJ
- SPU
- SH
- SHB
- SBB
- SOP
- SNP

# SPF Series

## Flat Suction Cup

---

### Mounting parts

Item	Model M - Male thread	Applicable suction cup
Fitting for suction cup	PJS-M3M-ST1	SPF2, 3.5
	PJS-M5M-ST2	SPF5, 6, 8, 10, 15
	PJS-M5M-ST3	SPF20
	PJS-M5M-ST4	SPF25, 30, 35, 40
	PJS-M8M-ST6	SPF50

# SPF Series

## Suction Cup with Locking Fitting

### Structure

- ◇ Consisting of replacement suction cup and locking fitting
- ◇ Plug-in fitting for suction cup
- ◇ Vertical vacuum port, Pagoda fitting or one-touch fitting for connection, male thread for mounting
- ◇ Lateral vacuum port, Pagoda fitting for connection, female thread for mounting

In the same series, replacement suction cup and locking fitting can be combined as required

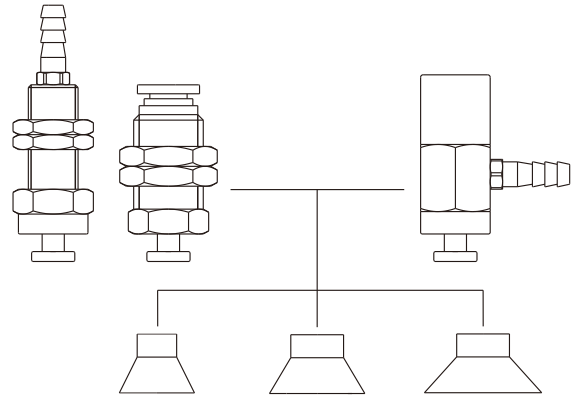

### How to order

**SPF10N - L B6 - M4F**

①                      ②                      ③                      ④

① Model	② Vacuum port direction	③ Vacuum port connection	④ Mounting thread
<b>SPF10N</b>	Nil - Vertical direction	A4 - One-touch fitting $\phi$ 4 hose	M3F - M3 $\times$ 0.5 female thread    M5M - M5 $\times$ 0.5 male thread
	L - Lateral direction	A6 - One-touch fitting $\phi$ 6 hose	M4F - M4 $\times$ 0.7 female thread    M8M - M8 $\times$ 1 male thread
		B4 - Pagoda fitting $\phi$ 4 hose	M6F - M6 $\times$ 1 female thread    M10M - M10 $\times$ 1 male thread
		B6 - Pagoda fitting $\phi$ 6 hose	M8F - M8 $\times$ 1.25 female thread    M12M - M12 $\times$ 1 male thread
		R1 - Rc1/8 female thread	M16F - M16 $\times$ 2 female thread    M14M - M14 $\times$ 1 male thread
			M16M - M16 $\times$ 1.5 male thread

◇ Please refer to page 312 for suction cup selection

### Selection

Model	Vacuum port direction Vertical-Pagoda fitting	Vertical-One-touch fitting	Lateral-Pagoda fitting
SPF2□	SPF2□-B4-M5M	-	SPF2□-LB4-M3F
SPF3.5□	SPF3.5□-B4-M5M	-	SPF3.5□-LB4-M3F
SPF5□	SPF5□-B6-M8M	SPF5□-A4-M12M	SPF5□-LB6-M4F
SPF6□	SPF6□-B6-M8M	SPF6□-A4-M12M	SPF6□-LB6-M4F
SPF8□	SPF8□-B6-M8M	SPF8□-A4-M12M	SPF8□-LB6-M4F
SPF10□	SPF10□-B6-M8M	SPF10□-A4-M12M	SPF10□-LB6-M4F
SPF15□	SPF15□-B6-M8M	SPF15□-A4-M12M	SPF15□-LB6-M4F
SPF20□	SPF20□-B6-M10M	SPF20□-A6-M14M	SPF20□-LB6-M4F
SPF25□	SPF25□-B6-M10M	SPF25□-A6-M14M	SPF25□-LB6-M6F
SPF30□	SPF30□-B6-M10M	SPF30□-A6-M14M	SPF30□-LB6-M6F
SPF35□	SPF35□-B6-M10M	SPF35□-A6-M14M	SPF35□-LB6-M6F
SPF40□	SPF40□-B6-M10M	SPF40□-A6-M14M	SPF40□-LB6-M6F
SPF50□	SPF50□-B6-M10M	SPF50□-A6-M14M	SPF50□-LB6-M6F

- SZ
- SPH
- SP3
- SUF
- SAN
- SAO
- SOFA
- STP
- SFT
- SFA
- SBT
- SBL
- SBLP
- SBS
- SFP
- SBP
- SXP
- SGP
- SBOF
- STC
- SFF
- SOB
- SOE
- SOG
- SFM
- SOM
- SBF
- SDM
- SFU
- SFK
- SHT
- SDL
- SFG
- SFGT
- SFD
- SB
- SBA
- SF
- SU
- SP2F
- SPA
- SPD
- SPF**
- SPC
- SPJ
- SPU
- SH
- SHB
- SBB
- SOP
- SNP

# SPF Series

## Suction Cup with Locking Fitting

### Selection

Model	Vacuum port direction Vertical-Pagoda fitting	Lateral-Pagoda fitting
SPF60□	SPF60□-R1-M16M	SPF60□-LR1-M8F
SPF80□	SPF80□-R1-M16M	SPF80□-LR1-M8F
SPF95□	SPF95□-R1-M16M	SPF95□-LR1-M8F
SPF120□	-	SPF120□-LR1-M16F
SPF150□	-	SPF150□-LR1-M16F
SPF200□	-	SPF200□-LR1-M16F

### Dimensions(mm)

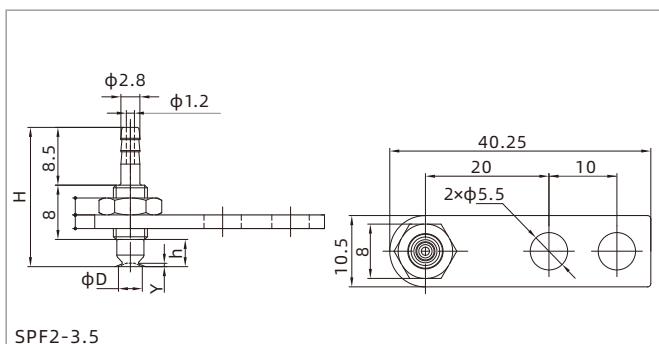

SPF2-3.5

Vertical-Pagoda fitting

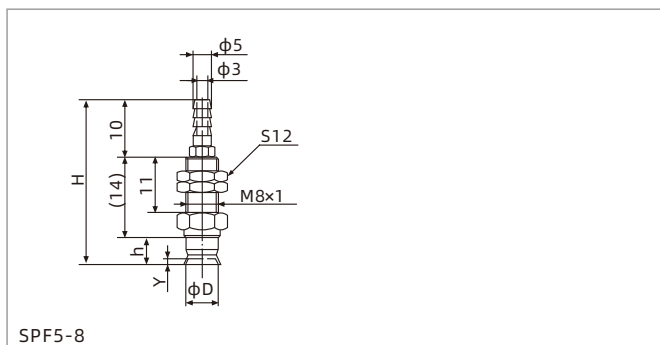

SPF5-8

Vertical-Pagoda fitting

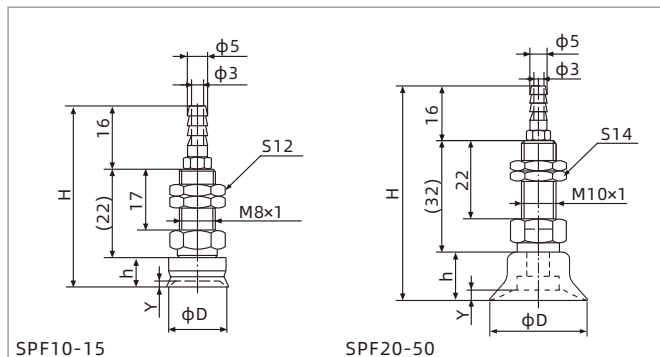

SPF10-15

SPF20-50

Vertical-Pagoda fitting

Model/Size	D	H	h	Y
SPF2□-B4-M5M	2	20.5	4	0.5
SPF3.5□-B4-M5M	3.5	20.5	4	0.5

Model/Size	D	H	h	Y
SPF5□-B6-M8M	5	30.5	6.5	0.8
SPF6□-B6-M8M	6	30.5	6.5	0.8
SPF8□-B6-M8M	8	31	7	1.2

Model/Size	D	H	h	Y
SPF10□-B6-M8M	10	45.5	7.5	1.5
SPF15□-B6-M8M	15	46	8	1.9
SPF20□-B6-M10M	20	58	10	2.3
SPF25□-B6-M10M	25	62	14	3
SPF30□-B6-M10M	30	60	12	2
SPF35□-B6-M10M	35	62	14	3
SPF40□-B6-M10M	40	62	14	3.5
SPF50□-B6-M10M	50	63	15	4

# SPF Series

## Suction Cup with Locking Fitting

### Dimensions(mm)

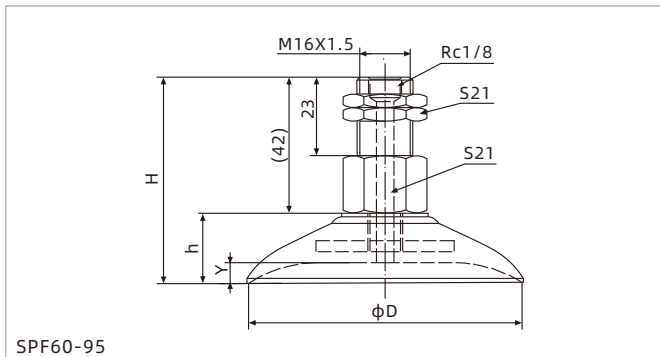

SPF60-95

Vertical-Female thread connection

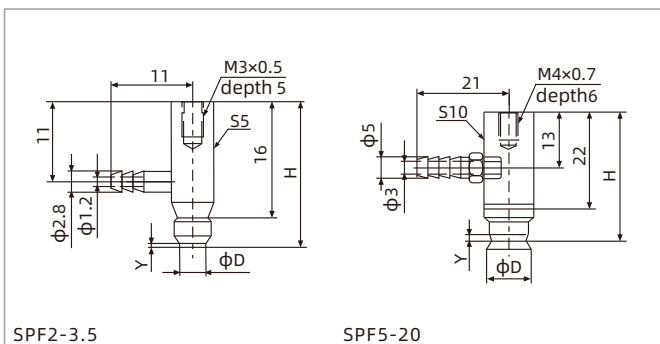

SPF2-3.5

SPF5-20

Lateral-Pagoda fitting

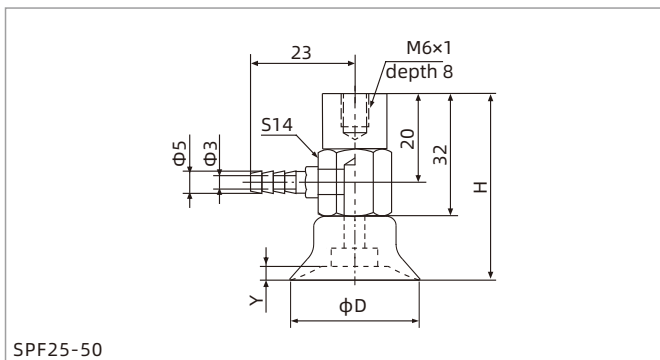

SPF25-50

Lateral-Pagoda fitting

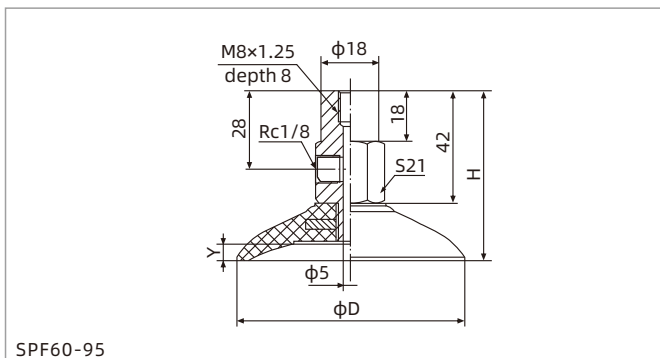

SPF60-95

Lateral-Female thread connection

Model/Size	D	H	h	Y
SPF60□-R1-M16M	60	58	16	5
SPF80□-R1-M16M	80	60	18	6
SPF95□-R1-M16M	95	60.5	18.5	6

Model/Size	D	H	Y
SPF2□-LB4-M3F	2	20	0.5
SPF3.5□-LB4-M3F	3.5	20	0.5
SPF5□-LB6-M4F	5	28.5	0.8
SPF6□-LB6-M4F	6	28.5	0.8
SPF8□-LB6-M4F	8	29	1.2
SPF10□-LB6-M4F	10	29.5	1.5
SPF15□-LB6-M4F	15	30	1.9
SPF20□-LB6-M4F	20	32	2.3

Model/Size	D	H	Y
SPF25□-LB6-M6F	25	46	3
SPF30□-LB6-M6F	30	44	2
SPF35□-LB6-M6F	35	46	3
SPF40□-LB6-M6F	40	46	3.5
SPF50□-LB6-M6F	50	47	4

Model/Size	D	H	Y
SPF60□-LR1-M8F	60	58	5
SPF80□-LR1-M8F	80	58.5	6
SPF95□-LR1-M8F	95	59	6

- SZ
- SPH
- SP3
- SUF
- SAN
- SAO
- SOFA
- STP
- SFT
- SFA
- SBT
- SBL
- SBLP
- SBS
- SFP
- SBP
- SXP
- SGP
- SBOF
- STC
- SFF
- SOB
- SOF
- SOG
- SFM
- SOM
- SBF
- SDM
- SFU
- SFK
- SHT
- SDL
- SFG
- SFGT
- SFD
- SB
- SBA
- SF
- SU
- SP2F
- SPA
- SPD
- SPF**
- SPC
- SPJ
- SPU
- SH
- SHB
- SBB
- SOP
- SNP

# SPF Series

## Suction Cup with Locking Fitting

### Dimensions(mm)

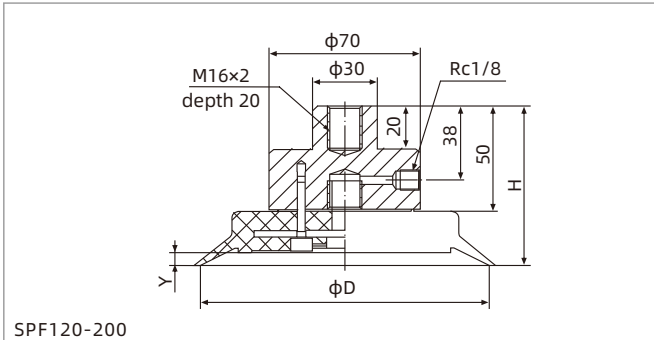

SPF120-200

Lateral-Female thread connection

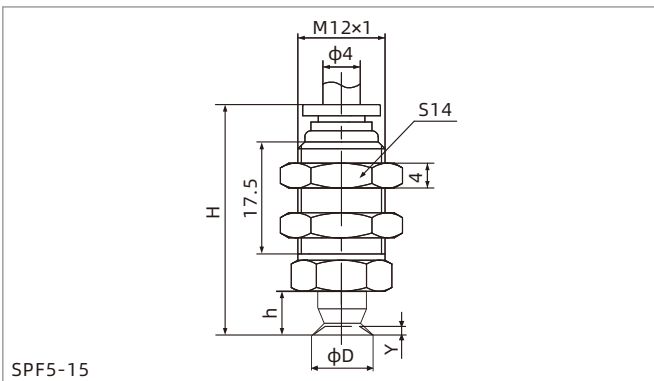

SPF5-15

Vertical-One-touch fitting

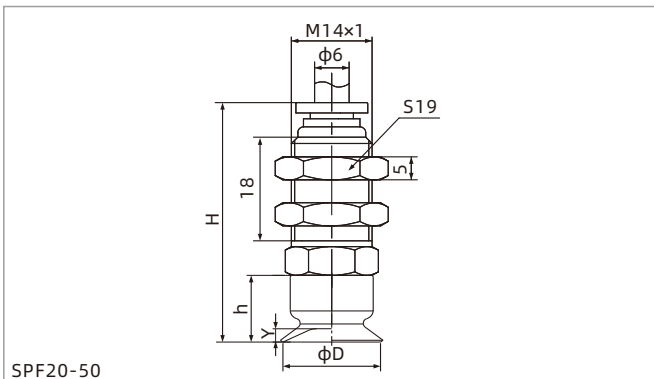

SPF20-50

Vertical-One-touch fitting

Model/Size	D	H	Y
SPF120□-LR1-M16F	120	75.5	6
SPF150□-LR1-M16F	150	82.5	9
SPF200□-LR1-M16F	200	87.5	13

Model/Size	D	H	Y
SPF5□-A4-M12M	5	34	0.8
SPF6□-A4-M12M	6	34	0.8
SPF8□-A4-M12M	8	34.5	1.2
SPF10□-A4-M12M	10	35	1.5
SPF15□-A4-M12M	15	35.5	1.9

Model/Size	D	H	Y
SPF20□-A6-M14M	20	39	2.3
SPF25□-A6-M14M	25	43	3
SPF30□-A6-M14M	30	41	2
SPF35□-A6-M14M	35	43	3
SPF40□-A6-M14M	40	43	3.5
SPF50□-A6-M14M	50	44	4

# SPF Series

## Suction Cup with Level Compensator

### Structure

- ◇ Consisting of replacement suction cup(3) and level compensator
- ◇ Plug-in fitting for suction cup
- ◇ Vertical vacuum port(1), male thread for mounting
- ◇ Lateral vacuum port(2), male thread for mounting

In the same series, replacement suction cup and level compensator can be combined as required

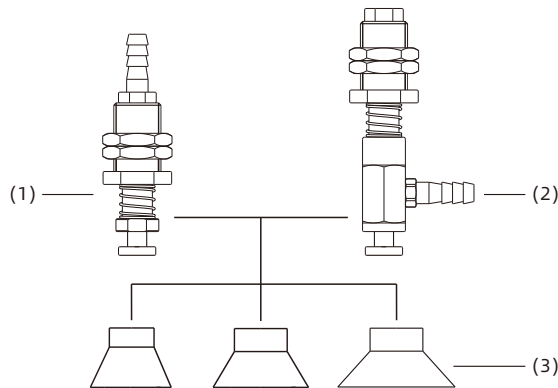

### How to order

**SPF10N - F E 10 LB6 - M11**

①                      ②   ③   ④                      ⑤                      ⑥

① Model	② Level compensator type	③ Buffer type	④ Buffer stroke	⑤ Vacuum port connection	⑥ Mounting thread
SPF10N	F - PSPF Series	E - External spring	2 5	B4 - Vertical, Pagoda fitting φ4 hose	M5 - M5×0.5
			3 10	B6 - Vertical, Pagoda fitting φ6 hose	M9 - M9×1
			4 15	LB4 - Lateral, Pagoda fitting φ4 hose	M11 - M11×1
			6 30	LB6 - Lateral, Pagoda fitting φ6 hose	M14 - M14×1
				LR1 - Lateral, Rc1/8 female thread	M16 - M16×1.5

### Selection

Model	Vacuum port direction Vertical-Pagoda fitting		Lateral-Pagoda fitting	
	SPF2□	SPF2□-FE2B4-M5	SPF2□-FE5B4-M5	SPF2□-FE2LB4-M5
SPF3.5□	SPF3.5□-FE2B4-M5	SPF3.5□-FE5B4-M5	SPF3.5□-FE2LB4-M5	SPF3.5□-FE5LB4-M5
SPF5□	SPF5□-FE3B6-M9	SPF5□-FE10B6-M9	SPF5□-FE3LB6-M9	SPF5□-FE10LB6-M9
SPF6□	SPF6□-FE3B6-M9	SPF6□-FE10B6-M9	SPF6□-FE3LB6-M9	SPF6□-FE10LB6-M9
SPF8□	SPF8□-FE3B6-M9	SPF8□-FE10B6-M9	SPF8□-FE3LB6-M9	SPF8□-FE10LB6-M9
SPF10□	SPF10□-FE4B6-M11	SPF10□-FE10B6-M11	SPF10□-FE4LB6-M11	SPF10□-FE10LB6-M11
SPF15□	SPF15□-FE4B6-M11	SPF15□-FE10B6-M11	SPF15□-FE4LB6-M11	SPF15□-FE10LB6-M11
SPF20□	SPF20□-FE4B6-M11	SPF20□-FE10B6-M11	SPF20□-FE4LB6-M11	SPF20□-FE10LB6-M11
SPF25□	SPF25□-FE6B6-M14	SPF25□-FE15B6-M14	SPF25□-FE6LB6-M14	SPF25□-FE15LB6-M14
SPF30□	SPF30□-FE6B6-M14	SPF30□-FE15B6-M14	SPF30□-FE6LB6-M14	SPF30□-FE15LB6-M14
SPF35□	SPF35□-FE6B6-M14	SPF35□-FE15B6-M14	SPF35□-FE6LB6-M14	SPF35□-FE15LB6-M14
SPF40□	SPF40□-FE6B6-M14	SPF40□-FE15B6-M14	SPF40□-FE6LB6-M14	SPF40□-FE15LB6-M14
SPF50□	SPF50□-FE6B6-M14	SPF50□-FE15B6-M14	SPF50□-FE6LB6-M14	SPF50□-FE15LB6-M14

- SZ
- SPH
- SP3
- SUF
- SAN
- SAO
- SOFA
- STP
- SFT
- SFA
- SBT
- SBL
- SBLP
- SBS
- SFP
- SBP
- SXP
- SGP
- SBOF
- STC
- SFF
- SOB
- SOF
- SOG
- SFM
- SOM
- SBF
- SDM
- SFU
- SFK
- SHT
- SDL
- SFG
- SFGT
- SFD
- SB
- SBA
- SF
- SU
- SP2F
- SPA
- SPD
- SPF
- SPC
- SPJ
- SPU
- SH
- SHB
- SBB
- SOP
- SNP

# SPF Series

## Suction Cup with Level Compensator



### Selection

Model	Vacuum port direction	Lateral-Pagoda fitting	
	Vertical-Pagoda fitting		
SPF60□	-	SPF60□-FE10LR1-M16	SPF60□-FE30LR1-M16
SPF80□	-	SPF80□-FE10LR1-M16	SPF80□-FE30LR1-M16
SPF95□	-	SPF95□-FE10LR1-M16	SPF95□-FE30LR1-M16

### Dimensions(mm)

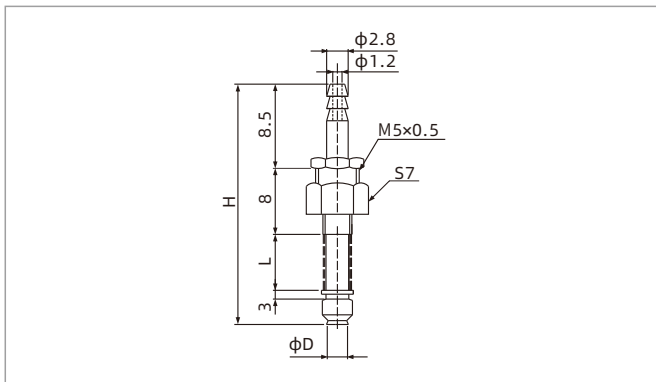

SPF2-3.5 Vertical-Pagoda fitting

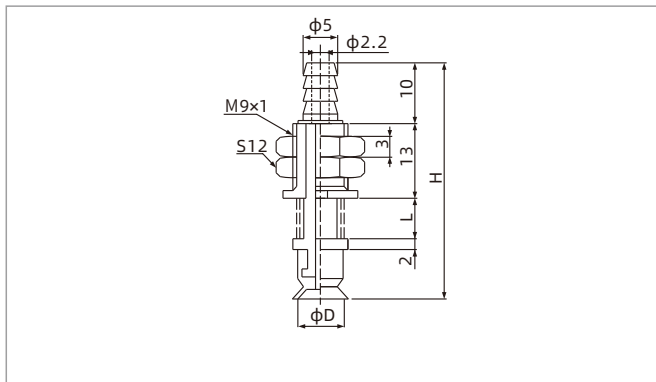

SPF5-8 Vertical-Pagoda fitting

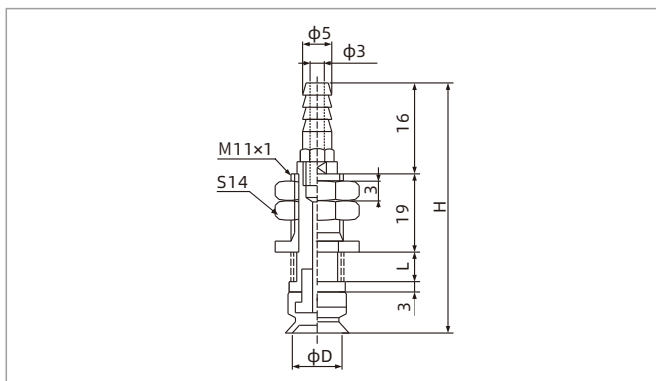

SPF10-20 Vertical-Pagoda fitting

Model/Size	D	H	L	Buffer stroke
SPF2□-FE2B4-M5	2	28.5	5	2.5
SPF2□-FE5B4-M5	2	33.5	10	5
SPF3.5□-FE2B4-M5	3.5	28.5	5	2.5
SPF3.5□-FE5B4-M5	3.5	33.5	10	5

Model/Size	D	H	L	Buffer stroke
SPF5□-FE3B6-M9	5	37.5	6	3
SPF5□-FE10B6-M9	5	51.5	20	10
SPF6□-FE3B6-M9	6	37.5	6	3
SPF6□-FE10B6-M9	6	51.5	20	10
SPF8□-FE3B6-M9	8	38	6	3
SPF8□-FE10B6-M9	8	52	20	10

Model/Size	D	H	L	Buffer stroke
SPF10□-FE4B6-M11	10	53.5	8	4
SPF10□-FE10B6-M11	10	65.5	20	10
SPF15□-FE4B6-M11	15	54	8	4
SPF15□-FE10B6-M11	15	66	20	10
SPF20□-FE4B6-M11	20	56	8	4
SPF20□-FE10B6-M11	20	68	20	10

# SPF Series

## Suction Cup with Level Compensator

### Dimensions(mm)

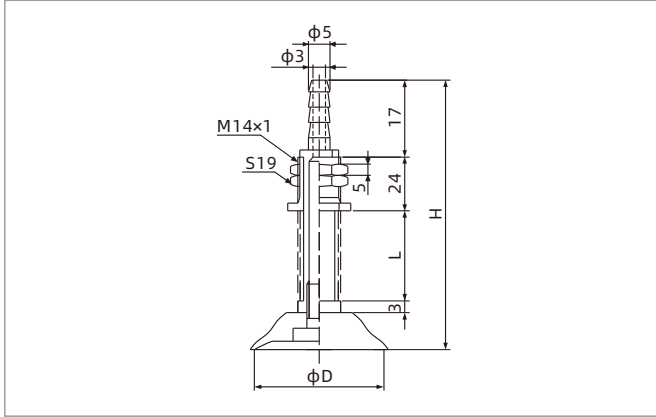

SPF25-50 Vertical-Pagoda fitting

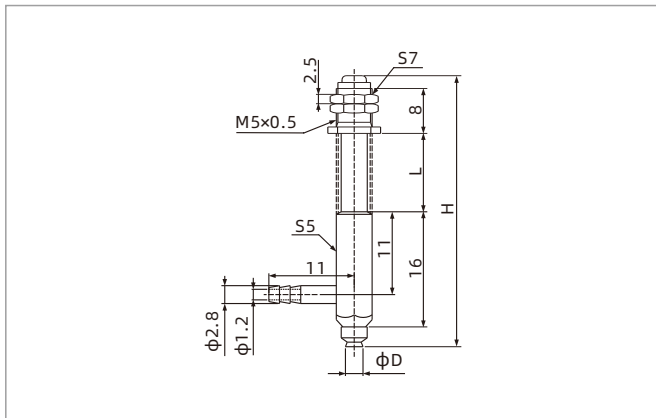

SPF2-3.5 Lateral-Pagoda fitting

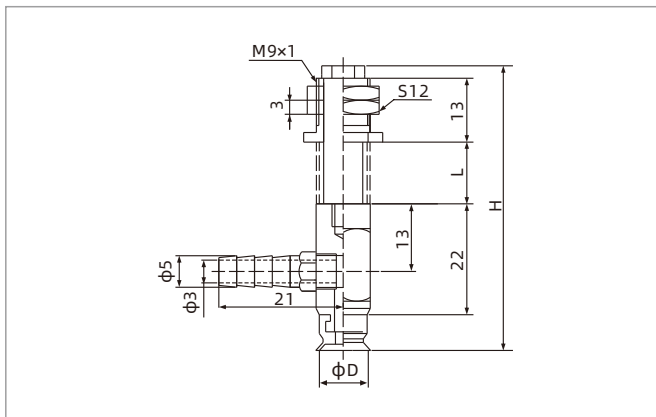

SPF5-8 Lateral-Pagoda fitting

Model/Size	D	H	L	Buffer stroke
SPF25□-FE6B6-M14	25	71	13	6
SPF25□-FE15B6-M14	25	88	30	15
SPF30□-FE6B6-M14	30	69	13	6
SPF30□-FE15B6-M14	30	86	30	15
SPF35□-FE6B6-M14	35	71	13	6
SPF35□-FE15B6-M14	35	88	30	15
SPF40□-FE6B6-M14	40	71	13	6
SPF40□-FE15B6-M14	40	88	30	15
SPF50□-FE6B6-M14	50	72	13	6
SPF50□-FE15B6-M14	50	89	30	15

Model/Size	D	H	L	Buffer stroke
SPF2□-FE2LB4-M5	2	35.5	5	2.5
SPF2□-FE5LB4-M5	2	40.5	10	5
SPF3.5□-FE2LB4-M5	3.5	35.5	5	2.5
SPF3.5□-FE5LB4-M5	3.5	40.5	10	5

Model/Size	D	H	L	Buffer stroke
SPF5□-FE3LB6-M9	5	50.5	6	3
SPF5□-FE10LB6-M9	5	64.5	20	10
SPF6□-FE3LB6-M9	6	50.5	6	3
SPF6□-FE10LB6-M9	6	64.5	20	10
SPF8□-FE3LB6-M9	8	51	6	3
SPF8□-FE10LB6-M9	8	65	20	10

- SZ
- SPH
- SP3
- SUF
- SAN
- SAO
- SOFA
- STP
- SFT
- SFA
- SBT
- SBL
- SBLP
- SBS
- SFP
- SBP
- SXP
- SGP
- SBOF
- STC
- SFF
- SOB
- SOF
- SOG
- SFM
- SOM
- SBF
- SDM
- SFU
- SFK
- SHT
- SDL
- SFG
- SFGT
- SFD
- SB
- SBA
- SF
- SU
- SP2F
- SPA
- SPD
- SPF**
- SPC
- SPJ
- SPU
- SH
- SHB
- SBB
- SOP
- SNP

# SPF Series

## Suction Cup with Level Compensator

### Dimensions(mm)

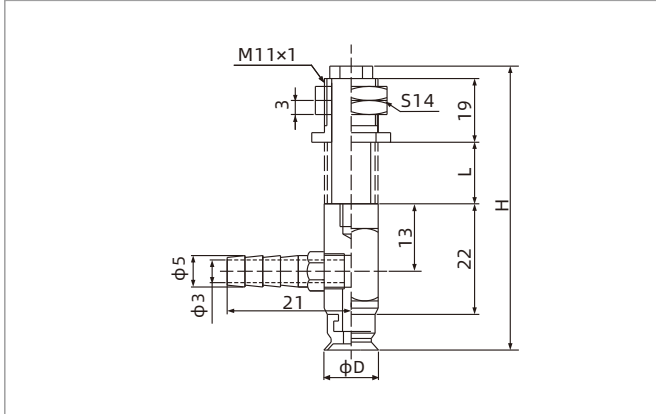

SPF10-20 Lateral-Pagoda fitting

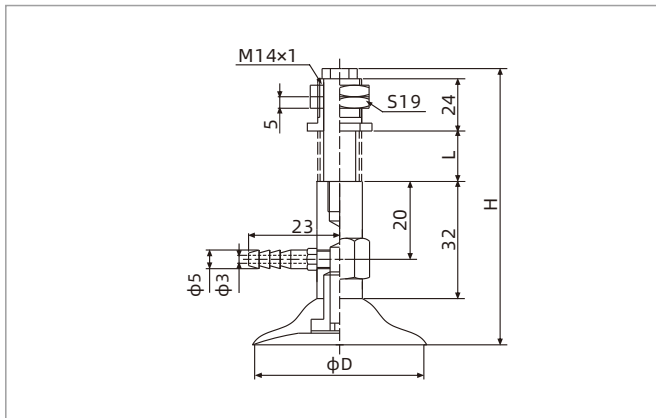

SPF25-50 Lateral-Pagoda fitting

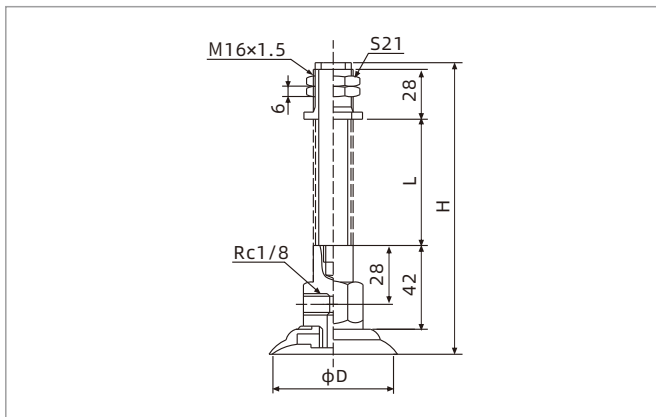

SPF60-95 Lateral-Female thread connection

Model/Size	D	H	L	Buffer stroke
SPF10□-FE4LB6-M11	10	59.5	8	4
SPF10□-FE10LB6-M11	10	71.5	20	10
SPF15□-FE4LB6-M11	15	60	8	4
SPF15□-FE10LB6-M11	15	72	20	10
SPF20□-FE4LB6-M11	20	62	8	4
SPF20□-FE10LB6-M11	20	74	20	10

Model/Size	D	H	L	Buffer stroke
SPF25□-FE6LB6-M14	25	87	13	6
SPF25□-FE15LB6-M14	25	104	30	15
SPF30□-FE6LB6-M14	30	85	13	6
SPF30□-FE15LB6-M14	30	102	30	15
SPF35□-FE6LB6-M14	35	87	13	6
SPF35□-FE15LB6-M14	35	104	30	15
SPF40□-FE6LB6-M14	40	87	13	6
SPF40□-FE15LB6-M14	40	104	30	15
SPF50□-FE6LB6-M14	50	88	13	6
SPF50□-FE15LB6-M14	50	105	30	15

Model/Size	D	H	L	Buffer stroke
SPF60□-FE10LR1-M16	60	110	20	10
SPF60□-FE30LR1-M16	60	150	60	30
SPF80□-FE10LR1-M16	80	112	20	10
SPF80□-FE30LR1-M16	80	152	60	30
SPF95□-FE10LR1-M16	95	112.5	20	10
SPF95□-FE30LR1-M16	95	152.5	60	30

# SPC Series

## Bellows Suction Cup



### Features

- ◇ 2.5 bellows
- ◇ Soft and tapered lips
- ◇ Available in various sizes

### Advantages

- ◇ Large suction force, and have good buffer effect when suck workpiece with uneven surface
- ◇ Good sealing and long compressed stroke, suitable for handling workpieces with uneven surface
- ◇ Suitable for workpieces of various sizes and shapes



### Applications

- ◇ Handling of fragile workpieces such as electronic components and injection molding parts
- ◇ Handling of workpieces with uneven surface such as paper and pipes

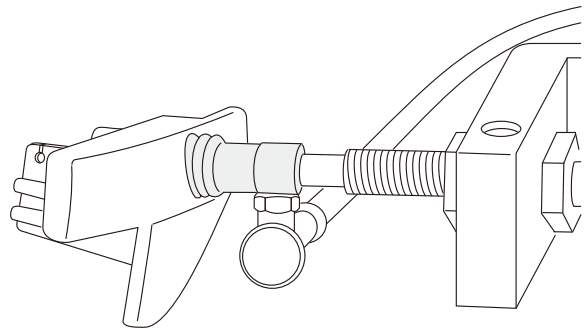

### Structure

- ◇ 2.5 bellows, long compressed stroke
- ◇ Split structure for easy replacement of wearing parts

In the same series, suction cup and fitting can be combined as required

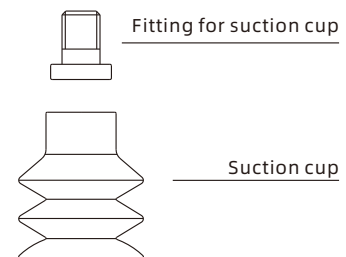

- SZ
- SPH
- SP3
- SUF
- SAN
- SAO
- SOFA
- STP
- SFT
- SFA
- SBT
- SBL
- SBLP
- SBS
- SFP
- SBP
- SXP
- SGP
- SBOF
- STC
- SFF
- SOB
- SOF
- SOG
- SFM
- SOM
- SBF
- SDM
- SFU
- SFK
- SHT
- SDL
- SFG
- SFGT
- SFD
- SB
- SBA
- SF
- SU
- SP2F
- SPA
- SPD
- SPF**
- SPC**
- SPJ
- SPU
- SH
- SHB
- SBB
- SOP
- SNP

# SPC Series

## Bellows Suction Cup

### How to order

## SPC 15 N - M5M

① ② ③ ④

① Series	② Diameter	③ Material & Hardness	④ Connection thread	
SPC	3 - $\phi$ 3mm	20 - $\phi$ 20mm	N - NBR <span style="background-color: black; color: white; padding: 0 2px;">55</span>	Nil - Suction cup only
	5 - $\phi$ 5mm	25 - $\phi$ 25mm	WS - White silicone <span style="border: 1px solid black; padding: 0 2px;">50</span>	M5M - M5×0.8 male thread
	7 - $\phi$ 7mm	30 - $\phi$ 30mm	CN - Conductive NBR <span style="background-color: black; color: white; padding: 0 2px;">55</span>	M8M - M8×1.25 male thread
	10 - $\phi$ 10mm	40 - $\phi$ 40mm	CS - Conductive silicone <span style="background-color: black; color: white; padding: 0 2px;">55</span>	G1M - G1/8 male thread
	12 - $\phi$ 12mm	60 - $\phi$ 60mm		M3M - M3×0.5 male thread
	15 - $\phi$ 15mm	90 - $\phi$ 90mm		
	18 - $\phi$ 18mm			

### Selection

Model	Connection thread M - Male thread	Model	Connection thread M - Male thread
SPC3□	SPC3□-M3M	SPC20□	SPC20□-M5M
SPC5□	SPC5□-M5M	SPC25□	SPC25□-M5M
SPC7□	SPC7□-M5M	SPC30□	SPC30□-M8M
SPC10□	SPC10□-M5M	SPC40□	SPC40□-M8M
SPC12□	SPC12□-M5M	SPC60□	SPC60□-M8M
SPC15□	SPC15□-M5M	SPC90□	SPC90□-G1M
SPC18□	SPC18□-M5M		

◇ Note: CN and CS material are not available for cup diameter 60mm and 90mm.

### Technical parameters

Model	Pull-out force N	Inner volume cm <sup>3</sup>	Min. Curve radius of workpiece mm	Weight g	Recommended hose dia. mm	MPQ pcs
SPC3	0.5	<0.1	4	0.2	4	10
SPC5	0.9	<0.1	7.5	0.2	4	10
SPC7	1.7	<0.1	12	0.3	4	10
SPC10	3.5	0.2	13	0.8	6	10
SPC12	5	0.4	13	1.3	6	10
SPC15	8	0.9	15	1.7	6	10
SPC18	11.5	1.5	20	1.8	6	10
SPC20	14	2	27	2.8	6	5
SPC25	22	5	30	4	6	5
SPC30	32	8.3	35	10.5	6	5
SPC40	56	16.5	60	22.5	8	5
SPC60	127	52	75	52.4	8	1
SPC90	286	135	85	152.8	8	1

◇ Note: Testing vacuum level -60kPa, workpiece with smooth and clean surface. The data of pull-out force as above are figured out without considering safety factor. The data may be different according to different workpiece surfaces. Recommend the length of vacuum hose to be as short as possible, max 2m.

# SPC Series

## Bellows Suction Cup

### Dimensions(mm) - Suction cup only

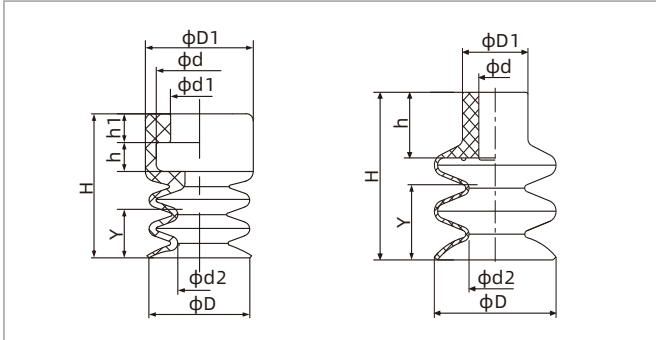

SPC3-7

SPC10-20

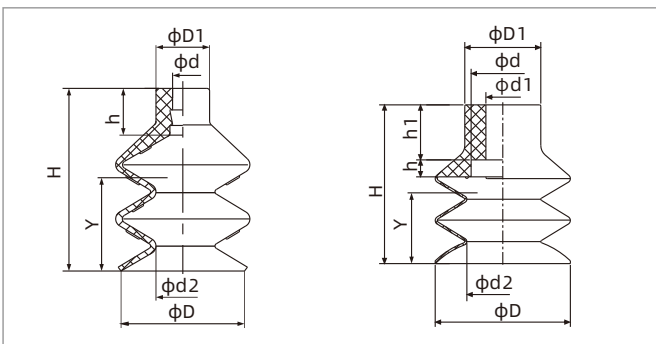

SPC12 SPC25

SPC30-90

Model/Size	D	H	D1	d	h	d1	h1	d2	Y
SPC3□	3	6	4	3	1	2	1.5	1.2	4
SPC5□	5	9.5	7.5	6	2	4	2	2	5.5
SPC7□	7	10	7.5	6	2	4	2	3	6
SPC10□	9	15	9	5	7	-	-	4	11.5
SPC15□	15.2	22.8	10	5	9	-	-	6	13.6
SPC18□	18.6	23	10	5	9	-	-	8	14
SPC20□	20.6	23	10	5	9	-	-	9.5	14

Model/Size	D	H	D1	d	h	d1	h1	d2	Y
SPC12□	13	21.6	10	3.8	8.5	-	-	5	13.5
SPC25□	24	34	10	3.8	8.5	-	-	10	18.5
SPC30□	32	37.5	18	15	4	8	13	17	24.8
SPC40□	42	46	20	15	4	8	13	16	28
SPC60□	62	55	21.5	15	5	8	13	29	30
SPC90□	88	87.5	25	25	6	12	20	32	54

### Dimensions(mm) - Suction cup with fitting

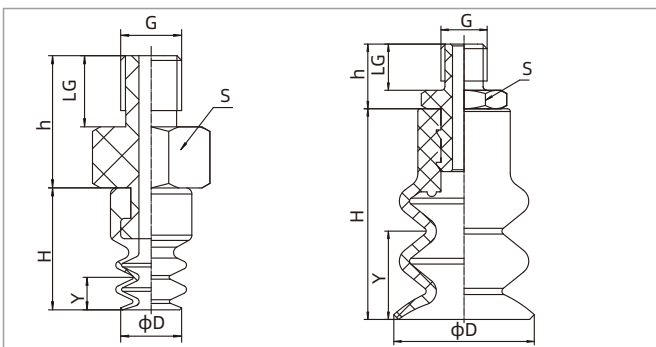

SPC3

SPC15-20

Model/Size	D	H	G	LG	h	s	Y
SPC3□-M3M	3	6	M3×0.5	3.5	6.5	5	4
SPC15□-M5M	15.2	22.8	M5×0.8	5	7	8	13.6
SPC18□-M5M	18.6	23	M5×0.8	5	7	8	14
SPC20□-M5M	20.6	23	M5×0.8	5	7	8	14

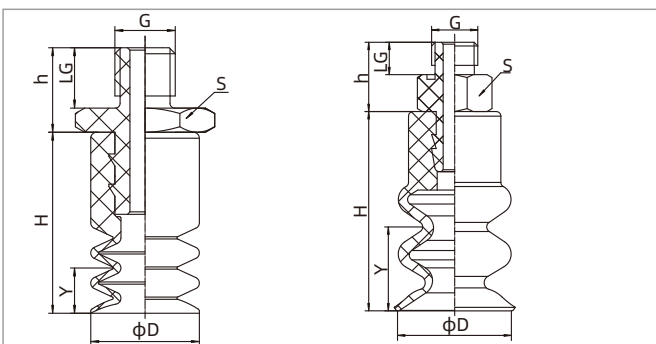

SPC10

SPC12-25

Model/Size	D	H	G	LG	h	S	Y
SPC10□-M5M	9	15	M5×0.8	5	7	10	11.5
SPC12□-M5M	13	21.6	M5×0.8	3.5	7.5	7	13.5
SPC25□-M5M	24	34	M5×0.8	3.5	7.5	7	18.5

◇ Note: "Y" is the height of suction cup after fully compressed

- SZ
- SPH
- SP3
- SUF
- SAN
- SAO
- SOFA
- STP
- SFT
- SFA
- SBT
- SBL
- SBLP
- SBS
- SFP
- SBP
- SXP
- SGP
- SBOF
- STC
- SFF
- SOB
- SOE
- SOG
- SFM
- SOM
- SBF
- SDM
- SFU
- SFK
- SHT
- SDL
- SFG
- SFGT
- SFD
- SB
- SBA
- SF
- SU
- SP2F
- SPA
- SPD
- SPF
- SPC**
- SPJ
- SPU
- SH
- SHB
- SBB
- SOP
- SNP

# SPC Series

## Bellows Suction Cup

### Dimensions(mm) - Suction cup with fitting

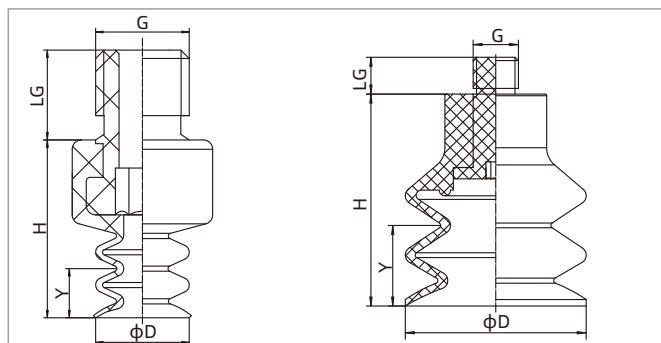

SPC5-7

SPC30-60

◇ Note: The dimensional tolerance conforms to GBT 3672.1-2002-1 M3 rubber product dimensional tolerance standard

Model/Size	D	H	G	LG	Y
SPC5□-M5M	5	9.5	M5×0.8	5	5.5
SPC7□-M5M	7	10	M5×0.8	5	6
SPC30□-M8M	32	37.5	M8×1.25	6.5	24.8
SPC40□-M8M	42	46	M8×1.25	6.5	28
SPC60□-M8M	62	55	M8×1.25	6.5	30
SPC90□-G1M	88	87.5	G1/8	7	54

### Mounting parts

Item	Model M - Male thread	Applicable suction cup
Fitting for suction cup	PJS-M3M-ST1	SPC3
	PJS-M5M-ST2	SPC5, 7
	PJS-M5M-SPC10	SPC10
	PJS-M5M-SPC15	SPC15, 18, 20
	PJS-M5M-SC3	SPC12, 25
	PJS-M8M-ST5	SPC30, 40, 60
	PJS-G1M-ST8	SPC90

# SPC Series

## Suction Cup with Locking Fitting

### Structure

- ◇ Consisting of replacement suction cup and locking fitting
- ◇ Plug-in fitting for suction cups of diameter 5mm-25mm
- ◇ Fitting with hexagon socket mounting hole for suction cups of diameter 30mm-60mm
- ◇ Vertical vacuum port, pagoda fitting for connection, male thread for mounting
- ◇ Lateral vacuum port, pagoda fitting for connection, female thread for mounting

In the same series, replacement suction cup and locking fitting can be combined as required

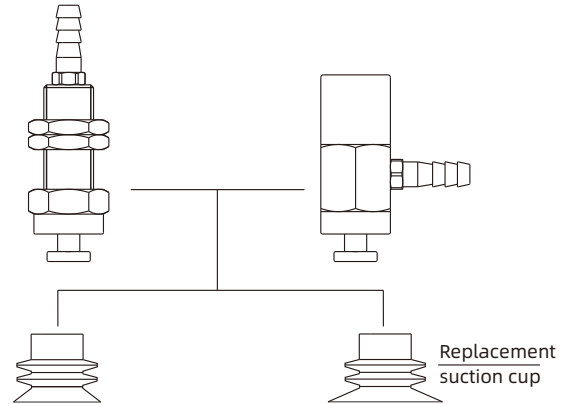

### How to order

SPC10N - L B6 - M4F  
 ①                      ②                      ③                      ④

① Model	② Vacuum port direction	③ Vacuum port connection	④ Mounting thread
SPC10N	Nil - Vertical direction L - Lateral direction	B6 - Pagoda fitting $\phi 6$ hose	M4F - M4x0.7 female thread M6F - M6x1 female thread M8M - M8x1 male thread M10M - M10x1 male thread

◇ Please refer to page 324 for suction cup selection

### Selection

Model	Vacuum port direction Vertical-Pagoda fitting	Lateral-Pagoda fitting
SPC3□	SPC3□-B6-M8M	SPC3□-LB6-M4F
SPC5□	SPC5□-B6-M8M	SPC5□-LB6-M4F
SPC7□	SPC7□-B6-M8M	SPC7□-LB6-M4F
SPC10□	SPC10□-B6-M8M	SPC10□-LB6-M4F
SPC12□	SPC12□-B6-M8M	SPC12□-LB6-M4F
SPC15□	SPC15□-B6-M8M	SPC15□-LB6-M4F
SPC18□	SPC18□-B6-M8M	SPC18□-LB6-M4F
SPC20□	SPC20□-B6-M8M	SPC20□-LB6-M4F
SPC25□	SPC25□-B6-M8M	SPC25□-LB6-M4F
SPC30□	SPC30□-B6-M10M	SPC30□-LB6-M6F
SPC40□	SPC40□-B6-M10M	SPC40□-LB6-M6F
SPC60□	SPC60□-B6-M10M	SPC60□-LB6-M6F

- SZ
- SPH
- SP3
- SUF
- SAN
- SAO
- SOFA
- STP
- SFT
- SFA
- SBT
- SBL
- SBLP
- SBS
- SFP
- SBP
- SXP
- SGP
- SBOF
- STC
- SFF
- SOB
- SOF
- SOG
- SFM
- SOM
- SBF
- SDM
- SFU
- SFK
- SHT
- SDL
- SFG
- SFGT
- SFD
- SB
- SBA
- SF
- SU
- SP2F
- SPA
- SPD
- SPF
- SPC**
- SPJ
- SPU
- SH
- SHB
- SBB
- SOP
- SNP

# SPC Series

## Suction Cup with Locking Fitting



### Dimensions(mm)

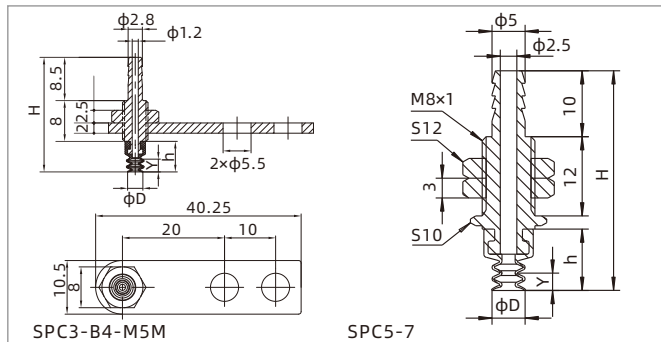

Vertical-Pagoda fitting

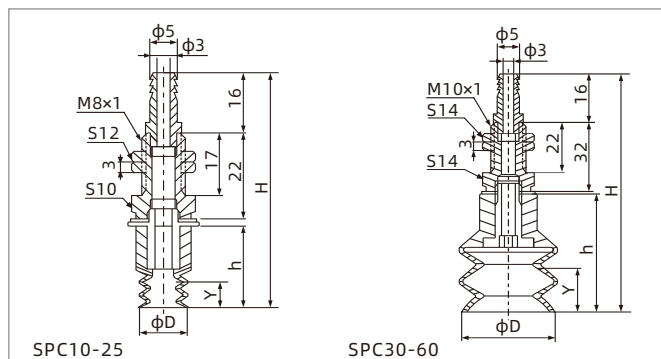

Vertical-Pagoda fitting

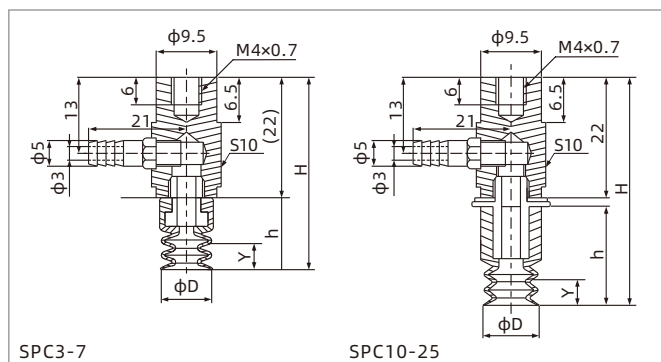

Lateral-Pagoda fitting

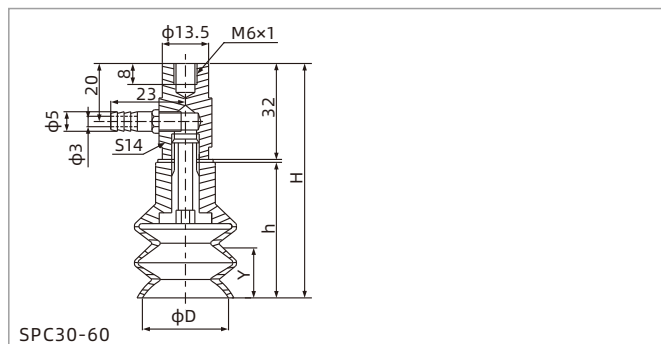

Lateral-Pagoda fitting

Model/Size	D	H	h	Y
SPC3□-B4-M5M	3	22.5	6	4
SPC5□-B6-M8M	5	33.5	9.5	5.5
SPC7□-B6-M8M	7	34	10	6
SPC10□-B6-M8M	10	55	15	11.5
SPC12□-B6-M8M	13	63.6	21.6	13.5
SPC15□-B6-M8M	15.2	62.8	22.8	13.6
SPC18□-B6-M8M	18.6	63	23	14
SPC20□-B6-M8M	20.6	63	23	14
SPC25□-B6-M8M	24	76	34	18.5

Model/Size	D	H	h	Y
SPC30□-B6-M10M	32	85.5	37.5	24.5
SPC40□-B6-M10M	42	94	46	28
SPC60□-B6-M10M	62	103	55	30

Model/Size	D	H	h	Y
SPC3□-LB6-M4F	3	28	6	4
SPC5□-LB6-M4F	5	31.5	9.5	5.5
SPC7□-LB6-M4F	7	32	10	6
SPC10□-LB6-M4F	10	39	15	11.5
SPC12□-LB6-M4F	13	47.6	21.6	13.5
SPC15□-LB6-M4F	15.2	46.8	22.8	13.6
SPC18□-LB6-M4F	18.6	47	23	14
SPC20□-LB6-M4F	20.6	47	23	14
SPC25□-LB6-M4F	24	60	34	18.5

Model/Size	D	H	h	Y
SPC30□-LB6-M6F	32	69.5	37.5	24.5
SPC40□-LB6-M6F	42	78	46	28
SPC60□-LB6-M6F	62	87	55	30

◇ Note: The dimensional tolerance conforms to GBT 3672.1-2002-1 M3 rubber product dimensional tolerance standard

# SPJ Series

## Bellows Suction Cup



PACKAGING



PLASTIC



### Features

- ◇ 1.5 bellows
- ◇ Soft and tapered lips
- ◇ Mark free plug optional
- ◇ Available in various sizes

### Advantages

- ◇ Compensate the height difference and good buffer when have contact with workpieces
- ◇ Good sealing for handling of workpieces with uneven surface
- ◇ Available in various sizes



### Applications

- ◇ Handling workpieces with uneven surface such as cartons, paper board and sheet, workpieces with curved surface
- ◇ Handling fragile workpieces such as electronic components and injection molding parts
- ◇ Suction cup with mark free plug is suitable for handling sensitive electronic material or display screen. It is suitable for occasions with high requirements for mark on adsorption surface

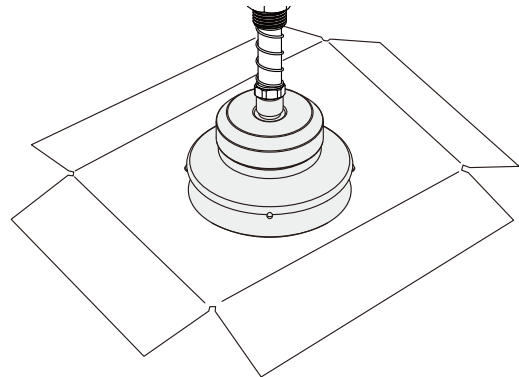

### Structure

- ◇ 1.5 bellows, long compressed stroke
- ◇ Suction cups with diameter less than 50mm adopt split structure for easy replacement
- ◇ One-piece structure for suction cup with diameter 60mm-80mm

In the same series, replacement suction cup and fitting can be combined as required

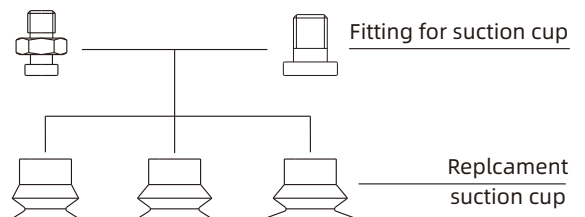

- SZ
- SPH
- SP3
- SUF
- SAN
- SAO
- SOFA
- STP
- SFT
- SFA
- SBT
- SBL
- SBLP
- SBS
- SFP
- SBP
- SXP
- SGP
- SBOF
- STC
- SFF
- SOB
- SOF
- SOG
- SFM
- SOM
- SBF
- SDM
- SFU
- SFK
- SHT
- SDL
- SFG
- SFGT
- SFD
- SB
- SBA
- SPJ
- SPU
- SH
- SHB
- SBB
- SOP
- SNP

# SPJ Series

## Bellows Suction Cup

### How to order

## SPJ 15 N - M5M - PK

①      ②      ③      ④      ⑤

① Series	② Diameter	③ Material & Hardness	④ Connection thread	⑤ Plug	
SPJ	4 - φ4mm	30 - φ30mm	N - NBR	55 Nil - Suction cup only	Nil - Without Mark free plug
	6 - φ6mm	35 - φ35mm	WS - White silicone	50 M3M - M3×0.5 male thread	PK - With mark free plug
	8 - φ8mm	40 - φ40mm	CN - Conductive NBR	55 M5M - M5×0.8 male thread	
	10 - φ10mm	50 - φ50mm	CS - Conductive silicone	55 M8M - M8×1.25 male thread	
	15 - φ15mm	60 - φ60mm	HP - Mark free rubber	55 M10F - M10×1.25 female thread	
	20 - φ20mm	70 - φ70mm			
	25 - φ25mm	80 - φ80mm			

◇ Note: HP material is not for all sizes. Please contact AIRBEST if need

### Selection

Model	Connection thread M - Male thread	Model	Connection thread M - Male thread	Connection thread F - Female thread
SPJ4□	SPJ4□-M3M	SPJ30□ SPJ30□-PK	SPJ30□-M5M SPJ30□-M5M-PK	-
SPJ6□	SPJ6□-M5M	SPJ35□ SPJ35□-PK	SPJ35□-M5M SPJ35□-M5M-PK	-
SPJ8□ SPJ8□-PK	SPJ8□-M5M SPJ8□-M5M-PK	SPJ40□ SPJ40□-PK	SPJ40□-M5M SPJ40□-M5M-PK	-
SPJ10□ SPJ10□-PK	SPJ10□-M5M SPJ10□-M5M-PK	SPJ50□ SPJ50□-PK	SPJ50□-M8M SPJ50□-M8M-PK	-
SPJ15□ SPJ15□-PK	SPJ15□-M5M SPJ15□-M5M-PK	SPJ60□	-	SPJ60□-M10F
SPJ20□ SPJ20□-PK	SPJ20□-M5M SPJ20□-M5M-PK	SPJ70□	-	SPJ70□-M10F
SPJ25□ SPJ25□-PK	SPJ25□-M5M SPJ25□-M5M-PK	SPJ80□	-	SPJ80□-M10F

### Technical parameters

Model	Pull-out force N	Inner volume cm <sup>3</sup>	Min. Curve radius of workpiece mm	Weight g	Recommended hose dia. mm	MPQ pcs
SPJ4	0.6	<0.1	4	0.1	4	10
SPJ6	1.2	<0.1	6	0.2	4	10
SPJ8	2.2	<0.1	8	0.3	4	10
SPJ10	3.5	0.2	12	0.8	4	10
SPJ15	8	0.5	20	1.0	6	10
SPJ20	15	1.1	27	1.8	6	5
SPJ25	24	2.2	40	3.0	6	5
SPJ30	32	3	55	5.3	6	5
SPJ35	43	4.5	65	8.0	6	5
SPJ40	60	6	80	10.5	6	1
SPJ50	92	11.7	95	21.0	8	1
SPJ60	127	20	125	35.6	8	1
SPJ70	173	30	150	52.5	8	1
SPJ80	226	40	140	63.0	8	1

◇ Note: Testing vacuum level -60kPa, workpiece with smooth and clean surface. The data of pull-out force as above are figured out without considering safety factor. The data may be different according to different workpiece surfaces. Recommend the length of vacuum hose to be as short as possible, max 2m.

# SPJ Series

## Bellows Suction Cup

### Dimensions(mm) - Suction cup only

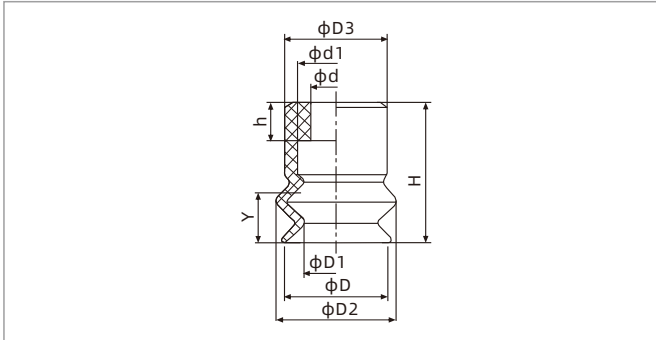

SPJ4-8

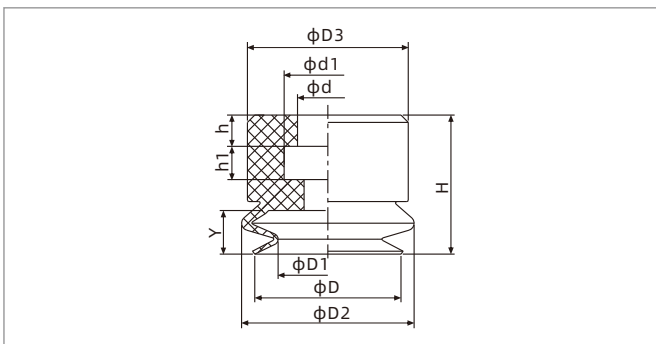

SPJ10-15

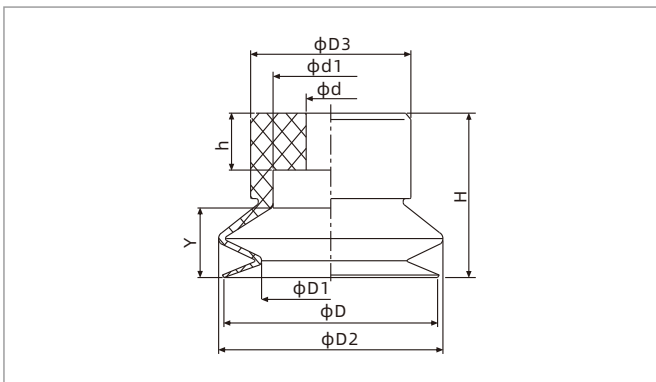

SPJ20-50

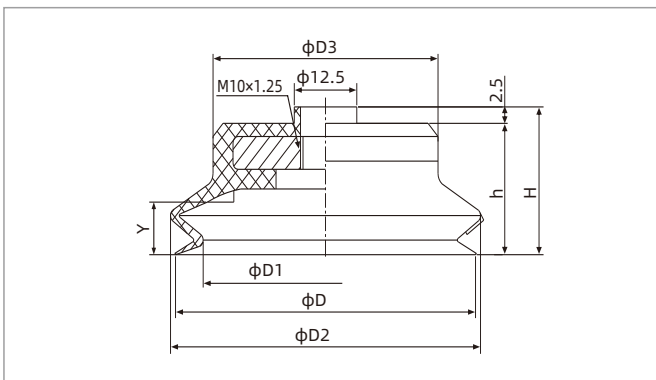

SPJ60-80

Model/Size	D	H	D1	D2	D3	d	h	d1	Y
SPJ4□	4	5.5	2.5	4.6	4	2	1.5	3	2.3
SPJ6□	6	9	3.3	7.8	7.5	4	2	6	4.2
SPJ8□	8	9	5.3	9.8	8	4	2	6	4

Model/Size	D	H	D1	D2	D3	d	h	d1	h1	Y
SPJ10□	10	9.5	6.8	11.8	11	4	2	6	2	3
SPJ15□	15	11	9.7	15.8	12	4	2	6	2	3.3

Model/Size	D	H	D1	D2	D3	d	h	d1	Y
SPJ20□	20	13	13	21	15	4.6	4.5	10.8	5.5
SPJ25□	25	15.5	14.5	26	17.5	4.6	4.5	10.8	6.5
SPJ30□	30	18	16	31	20	5.8	7	10.8	7
SPJ35□	35	18	20.5	36	25	5.8	7	10.8	7
SPJ40□	40	18	25	40	30	5.8	7	10.8	7.2
SPJ50□	50	20	32	53	40	7.8	7	19.8	9

Model/Size	D	H	h	D1	D2	D3	Y
SPJ60□-M10F	60	22.5	20	45	62	45	8
SPJ70□-M10F	70	23.5	21	52	74	55	9.5
SPJ80□-M10F	80	23.5	21	61	82	68	9.5

- SZ
- SPH
- SP3
- SUF
- SAN
- SAO
- SOFA
- STP
- SFT
- SFA
- SBT
- SBL
- SBLP
- SBS
- SFP
- SBP
- SXP
- SGP
- SBOF
- STC
- SFF
- SOB
- SOF
- SOG
- SFM
- SOM
- SBF
- SDM
- SFU
- SFK
- SHT
- SDL
- SFG
- SFGT
- SFD
- SB
- SBA
- SF
- SU
- SP2F
- SPA
- SPD
- SPF
- SPC
- SPJ**
- SPU
- SH
- SHB
- SBB
- SOP
- SNP

# SPJ Series

## Bellows Suction Cup

### Dimensions(mm)

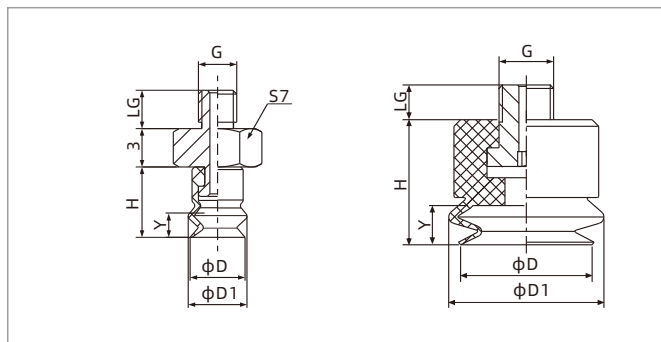

SPJ4

SPJ6-15

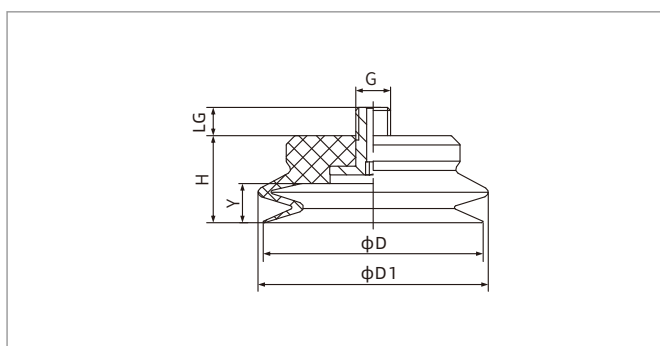

SPJ20-50

Model/Size	D	H	D1	G	LG	Y
SPJ4□-M3M	4	5.5	4.6	M3×0.5	3.5	2.3
SPJ6□-M5M	6	9	7.8	M5×0.8	4.5	4.2
SPJ8□-M5M	8	9	9.8	M5×0.8	4.5	4
SPJ10□-M5M	10	9.5	11.8	M5×0.8	4.5	3
SPJ15□-M5M	15	11	15.8	M5×0.8	4.5	3.3

Model/Size	D	H	D1	G	LG	Y
SPJ20□-M5M	20	13	21	M5×0.8	5	5.5
SPJ25□-M5M	25	15.5	26	M5×0.8	5	6.5
SPJ30□-M5M	30	18	31	M5×0.8	5	7
SPJ35□-M5M	35	18	36	M5×0.8	5	7
SPJ40□-M5M	40	18	40	M5×0.8	5	7.2
SPJ50□-M8M	50	20	53	M8×1.25	6.5	9

◇ Note: The dimensional tolerance conforms to GBT 3672.1-2002-1 M3 rubber product dimensional tolerance standard

### Mounting parts

Item	Model M - Male thread	Applicable suction cup
Fitting for suction cup	PJS-M3M-ST1	SPJ4
	PJS-M5M-ST2	SPJ6, 8, 10, 15
	PJS-M5M-ST3	SPJ20, 25
	PJS-M5M-ST4	SPJ30, 35, 40
	PJS-M8M-ST6	SPJ50

# SPJ Series

## Suction Cup with Locking Fitting

### Structure

- ◇ Consisting of replacement suction cup and locking fitting
- ◇ Plug-in fitting for suction cups
- ◇ Vertical vacuum port, pagoda fitting or one-touch fitting for connection, male thread for mounting
- ◇ Lateral vacuum port, pagoda fitting for connection, female thread for mounting

In the same series, replacement suction cup and locking fitting can be combined as required

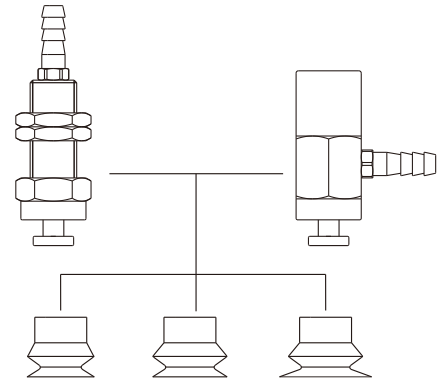

### How to order

**SPJ10N - L B6 - M4F**  
 ①                      ②    ③                      ④

① Series	② Vacuum port direction	③ Vacuum port connection	④ Mounting thread	
SPJ10N	Nil - Vertical	B6 - Pagoda fitting φ6 hose	M4F - M4x0.7 female thread	M8M - M8x1 male thread
	L - Lateral	R1 - Rc1/8 female thread	M6F - M6x1 female thread	M10M - M10x1 male thread
			M8F - M8x1.25 female thread	M16M - M16x1.5 male thread

◇ Please refer to page 330 for suction cup selection

### Selection

Model	Vacuum port direction Vertical-Pagoda fitting	Lateral-Pagoda fitting
SPJ6□	SPJ6□-B6-M8M	SPJ6□-LB6-M4F
SPJ8□	SPJ8□-B6-M8M	SPJ8□-LB6-M4F
SPJ10□	SPJ10□-B6-M8M	SPJ10□-LB6-M4F
SPJ15□	SPJ15□-B6-M8M	SPJ15□-LB6-M4F
SPJ20□	SPJ20□-B6-M8M	SPJ20□-LB6-M4F
SPJ25□	SPJ25□-B6-M10M	SPJ25□-LB6-M6F
SPJ30□	SPJ30□-B6-M10M	SPJ30□-LB6-M6F
SPJ35□	SPJ35□-B6-M10M	SPJ35□-LB6-M6F
SPJ40□	SPJ40□-B6-M10M	SPJ40□-LB6-M6F
SPJ50□	SPJ50□-B6-M10M	SPJ50□-LB6-M6F
SPJ60□	SPJ60□-R1-M16M	SPJ60□-LR1-M8F
SPJ70□	SPJ70□-R1-M16M	SPJ70□-LR1-M8F
SPJ80□	SPJ80□-R1-M16M	SPJ80□-LR1-M8F

- SZ
- SPH
- SP3
- SUF
- SAN
- SAO
- SOFA
- STP
- SFT
- SFA
- SBT
- SBL
- SBLP
- SBS
- SFP
- SBP
- SXP
- SGP
- SBOF
- STC
- SFF
- SOB
- SOF
- SOG
- SFM
- SOM
- SBF
- SDM
- SFU
- SFK
- SHT
- SDL
- SFG
- SFGT
- SFD
- SB
- SBA
- SF
- SU
- SP2F
- SPA
- SPD
- SPF
- SPC
- SPJ**
- SPU
- SH
- SHB
- SBB
- SOP
- SNP

# SPJ Series

## Suction Cup with Locking Fitting

### Dimensions(mm)

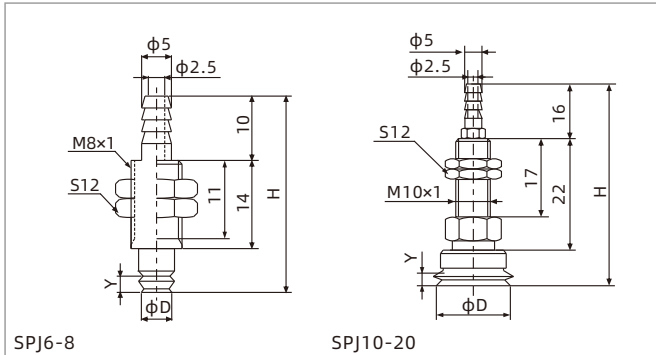

Vertical-Pagoda fitting

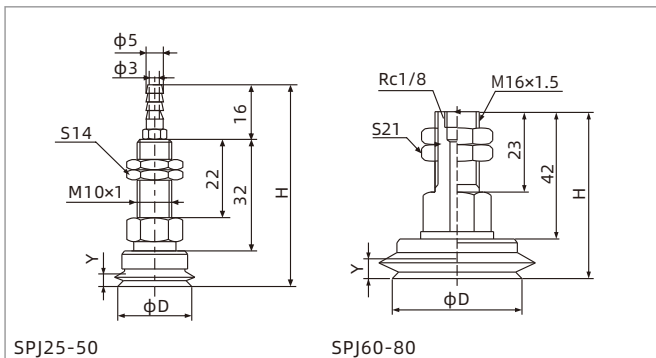

Vertical-Pagoda fitting

Vertical-Female thread connection

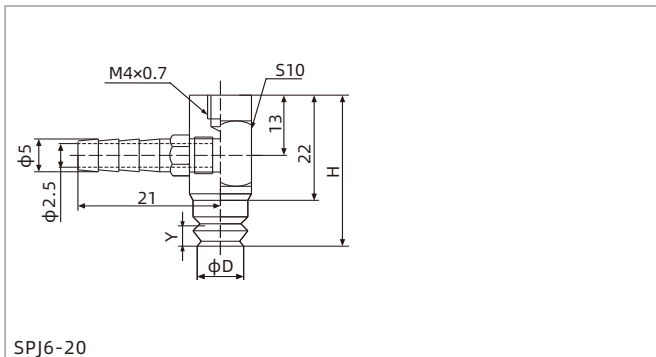

Lateral-Pagoda fitting

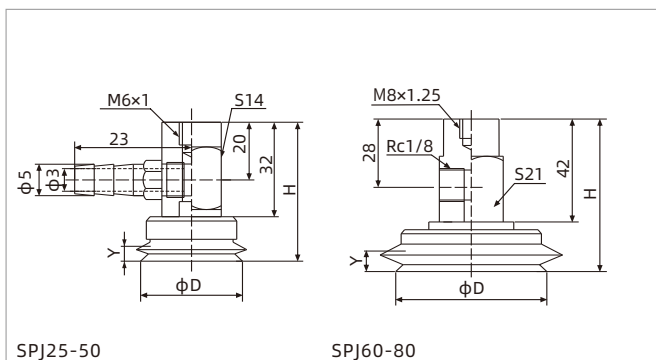

Lateral-Pagoda fitting

Lateral-Female thread connection

Model/Size	D	H	Y
SPJ6□-B6-M8M	6	33	4.2
SPJ8□-B6-M8M	8	33	4
SPJ10□-B6-M8M	10	47.5	3
SPJ15□-B6-M8M	15	49	3.3
SPJ20□-B6-M8M	20	51	5.5

Model/Size	D	H	Y
SPJ25□-B6-M10M	25	63.5	6.5
SPJ30□-B6-M10M	30	66	7
SPJ35□-B6-M10M	35	66	7
SPJ40□-B6-M10M	40	66	7.2
SPJ50□-B6-M10M	50	68	9
SPJ60□-R1-M16M	60	62	8
SPJ70□-R1-M16M	70	63	9.5
SPJ80□-R1-M16M	80	63	9.5

Model/Size	D	H	Y
SPJ6□-LB6-M4F	6	31	4.2
SPJ8□-LB6-M4F	8	31	4
SPJ10□-LB6-M4F	10	31.5	3
SPJ15□-LB6-M4F	15	33	3.3
SPJ20□-LB6-M4F	20	35	5.5

Model/Size	D	H	Y
SPJ25□-LB6-M6F	25	47.5	6.5
SPJ30□-LB6-M6F	30	50	7
SPJ35□-LB6-M6F	35	50	7
SPJ40□-LB6-M6F	40	50	7.2
SPJ50□-LB6-M6F	50	52	9
SPJ60□-LR1-M8F	60	62	8
SPJ70□-LR1-M8F	70	63	9.5
SPJ80□-LR1-M8F	80	63	9.5

# SPJ Series

## Suction Cup with Level Compensator

### Structure

- ◇ Consisting of replacement suction cup(3) and level compensator
- ◇ Plug-in fitting for suction cup
- ◇ Vertical vacuum port(1), male thread for mounting
- ◇ Lateral vacuum port(2), male thread for mounting

In the same series, replacement suction cup and level compensator can be combined as required

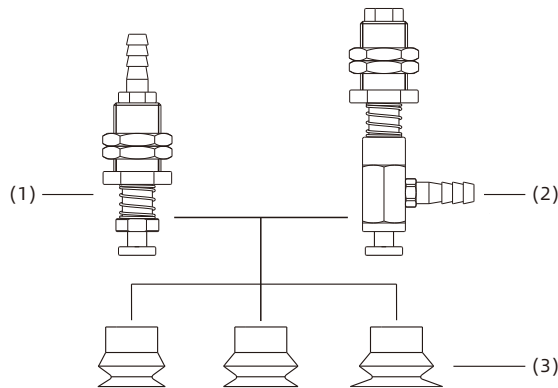

### How to order

**SPJ10N - F E 10 LB6 - M11**

①                    ②   ③                    ④                    ⑤                    ⑥

① Model	② Level compensator type	③ Buffer type	④ Buffer stroke	⑤ Vacuum port connection	⑥ Mounting thread	
SPJ10N	F - PSPF Series	E - External spring	3	10	B6 - Vertical, Pagoda fitting $\phi 6$ hose	M9 - M9 $\times$ 1
			4	15	LB6 - Lateral, Pagoda fitting $\phi 6$ hose	M11 - M11 $\times$ 1
			6	30	LR1 - Lateral, Rc1/8 Female thread	M14 - M14 $\times$ 1
						M16 - M16 $\times$ 1.5

### Selection

Model	Vacuum port direction Vertical-Pagoda fitting		Lateral-Pagoda fitting	
SPJ6□	SPJ6□-FE3B6-M9	SPJ6□-FE10B6-M9	SPJ6□-FE3LB6-M9	SPJ6□-FE10LB6-M9
SPJ8□	SPJ8□-FE3B6-M9	SPJ8□-FE10B6-M9	SPJ8□-FE3LB6-M9	SPJ8□-FE10LB6-M9
SPJ10□	SPJ10□-FE4B6-M11	SPJ10□-FE10B6-M11	SPJ10□-FE4LB6-M11	SPJ10□-FE10LB6-M11
SPJ15□	SPJ15□-FE4B6-M11	SPJ15□-FE10B6-M11	SPJ15□-FE4LB6-M11	SPJ15□-FE10LB6-M11
SPJ20□	SPJ20□-FE4B6-M11	SPJ20□-FE10B6-M11	SPJ20□-FE4LB6-M11	SPJ20□-FE10LB6-M11
SPJ25□	SPJ25□-FE6B6-M14	SPJ25□-FE15B6-M14	SPJ25□-FE6LB6-M14	SPJ25□-FE15LB6-M14
SPJ30□	SPJ30□-FE6B6-M14	SPJ30□-FE15B6-M14	SPJ30□-FE6LB6-M14	SPJ30□-FE15LB6-M14
SPJ35□	SPJ35□-FE6B6-M14	SPJ35□-FE15B6-M14	SPJ35□-FE6LB6-M14	SPJ35□-FE15LB6-M14
SPJ40□	SPJ40□-FE6B6-M14	SPJ40□-FE15B6-M14	SPJ40□-FE6LB6-M14	SPJ40□-FE15LB6-M14
SPJ50□	SPJ50□-FE6B6-M14	SPJ50□-FE15B6-M14	SPJ50□-FE6LB6-M14	SPJ50□-FE15LB6-M14
SPJ60□	-		SPJ60□-FE10LR1-M16	SPJ60□-FE30LB6-M16
SPJ70□	-		SPJ70□-FE10LR1-M16	SPJ70□-FE30LB6-M16
SPJ80□	-		SPJ80□-FE10LR1-M16	SPJ80□-FE30LB6-M16

- SZ
- SPH
- SP3
- SUF
- SAN
- SAO
- SOFA
- STP
- SFT
- SFA
- SBT
- SBL
- SBLP
- SBS
- SFP
- SBP
- SXP
- SGP
- SBOF
- STC
- SFF
- SOB
- SOF
- SOG
- SFM
- SOM
- SBF
- SDM
- SFU
- SFK
- SHT
- SDL
- SFG
- SFGT
- SFD
- SB
- SBA
- SF
- SU
- SP2F
- SPA
- SPD
- SPF
- SPC
- SPJ**
- SPU
- SH
- SHB
- SBB
- SOP
- SNP

# SPJ Series

## Suction Cup with Level Compensator

### Dimensions(mm)

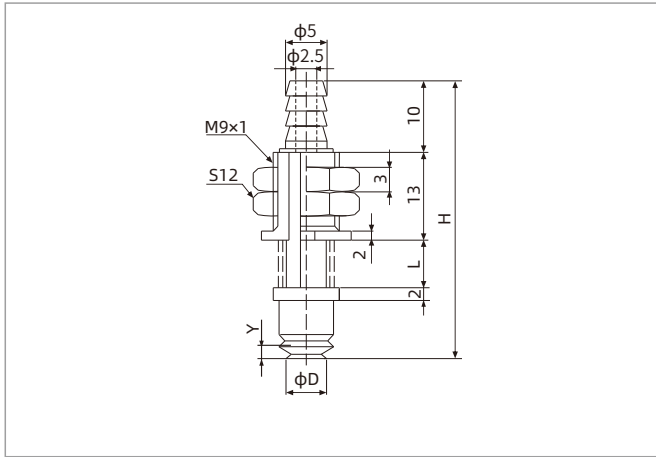

SPJ6-8 Vertical-Pagoda fitting

Model/Size	D	H	L	Y	Buffer stroke
SPJ6□-FE3B6-M9	6	40	6	4.2	3
SPJ6□-FE10B6-M9	6	54	20	4.2	10
SPJ8□-FE3B6-M9	8	40	6	4	3
SPJ8□-FE10B6-M9	8	54	20	4	10

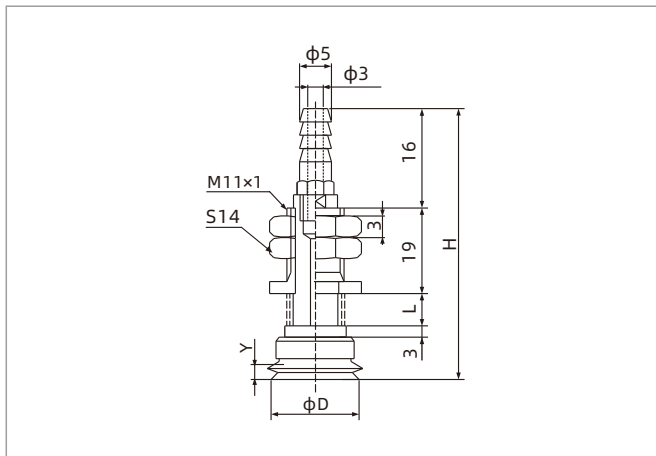

SPJ10-20 Vertical-Pagoda fitting

Model/Size	D	H	L	Y	Buffer stroke
SPJ10□-FE4B6-M11	10	55.5	8	3	4
SPJ10□-FE10B6-M11	10	67.5	20	3	10
SPJ15□-FE4B6-M11	15	57	8	3.3	4
SPJ15□-FE10B6-M11	15	69	20	3.3	10
SPJ20□-FE4B6-M11	20	59	8	5.5	4
SPJ20□-FE10B6-M11	20	71	20	5.5	10

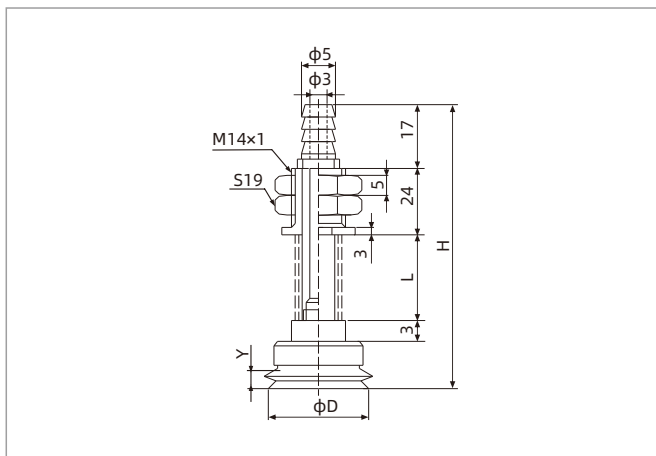

SPJ25-50 Vertical-Pagoda fitting

Model/Size	D	H	L	Y	Buffer stroke
SPJ25□-FE6B6-M14	25	72.5	13	6.5	6
SPJ25□-FE15B6-M14	25	89.5	30	6.5	15
SPJ30□-FE6B6-M14	30	75	13	7	6
SPJ30□-FE15B6-M14	30	92	30	7	15
SPJ35□-FE6B6-M14	35	75	13	7	6
SPJ35□-FE15B6-M14	35	92	30	7	15
SPJ40□-FE6B6-M14	40	75	13	7.2	6
SPJ40□-FE15B6-M14	40	92	30	7.2	15
SPJ50□-FE6B6-M14	50	77	13	9	6
SPJ50□-FE15B6-M14	50	94	30	9	15

# SPJ Series

## Suction Cup with Level Compensator

### Dimensions(mm)

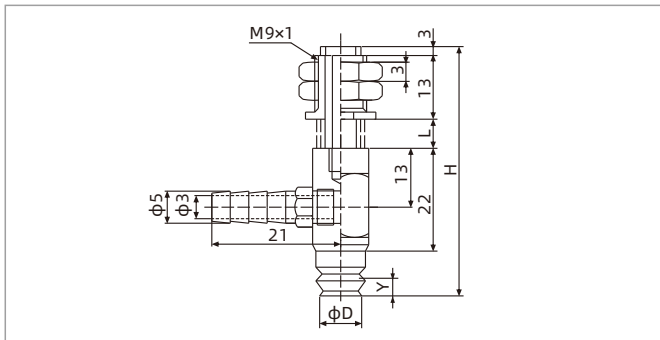

SPJ6-8 Lateral-Pagoda fitting

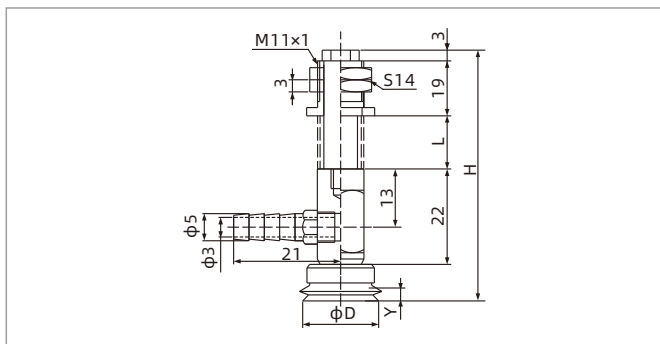

SPJ10-20 Lateral-Pagoda fitting

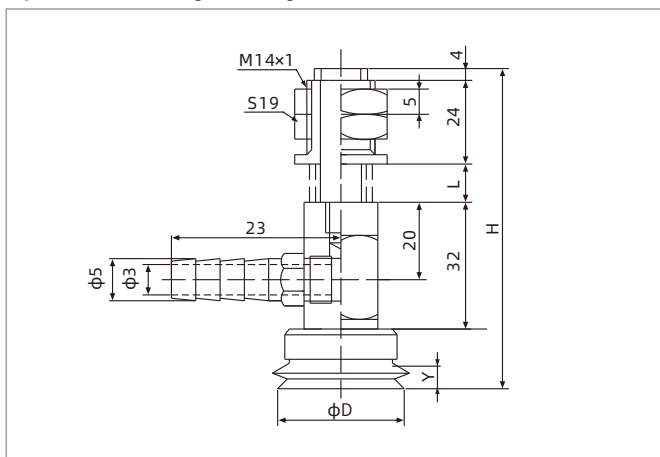

SPJ25-50 Lateral-Pagoda fitting

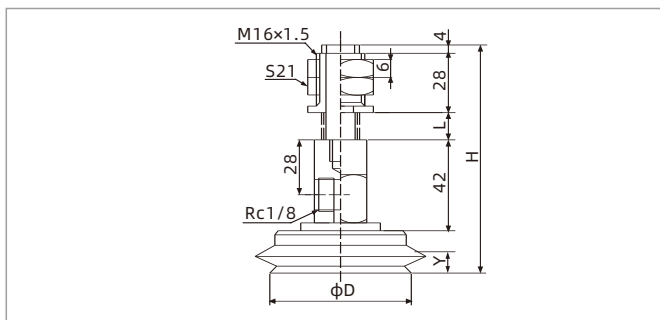

SPJ60-80 Lateral-Female thread connection

Model/Size	D	H	L	Y	Buffer stroke
SPJ6□-FE3LB6-M9	6	53	6	4.2	3
SPJ6□-FE10LB6-M9	6	67	20	4.2	10
SPJ8□-FE3LB6-M9	8	53	6	4	3
SPJ8□-FE10LB6-M9	8	67	20	4	10

Model/Size	D	H	L	Y	Buffer stroke
SPJ10□-FE4LB6-M11	10	61.5	8	3	4
SPJ10□-FE10LB6-M11	10	73.5	20	3	10
SPJ15□-FE4LB6-M11	15	63	8	3.3	4
SPJ15□-FE10LB6-M11	15	75	20	3.3	10
SPJ20□-FE4LB6-M11	20	65	8	5.5	4
SPJ20□-FE10LB6-M11	20	77	20	5.5	10

Model/Size	D	H	L	Y	Buffer stroke
SPJ25□-FE6LB6-M14	25	88.5	13	6.5	6
SPJ25□-FE15LB6-M14	25	105.5	30	6.5	15
SPJ30□-FE6LB6-M14	30	91	13	7	6
SPJ30□-FE15LB6-M14	30	108	30	7	15
SPJ35□-FE6LB6-M14	35	91	13	7	6
SPJ35□-FE15LB6-M14	35	108	30	7	15
SPJ40□-FE6LB6-M14	40	91	13	7.2	6
SPJ40□-FE15LB6-M14	40	108	30	7.2	15
SPJ50□-FE6LB6-M14	50	93	13	9	6
SPJ50□-FE15LB6-M14	50	110	30	9	15

Model/size	D	H	L	Y	Buffer stroke
SPJ60□-FE10LR1-M16	60	114	20	8	10
SPJ60□-FE30LR1-M16	60	154	60	8	30
SPJ70□-FE10LR1-M16	70	115	20	9.5	10
SPJ70□-FE30LR1-M16	70	155	60	9.5	30
SPJ80□-FE10LR1-M16	80	115	20	9.5	10
SPJ80□-FE30LR1-M16	80	155	60	9.5	30

- SZ
- SPH
- SP3
- SUF
- SAN
- SAO
- SOFA
- STP
- SFT
- SFA
- SBT
- SBL
- SBLP
- SBS
- SFP
- SBP
- SXP
- SGP
- SBOF
- STC
- SFF
- SOB
- SOF
- SOG
- SFM
- SOM
- SBF
- SDM
- SFU
- SFK
- SHT
- SDL
- SFG
- SFGT
- SFD
- SB
- SBA
- SF
- SU
- SP2F
- SPA
- SPD
- SPF
- SPC
- SPJ**
- SPU
- SH
- SHB
- SBB
- SOP
- SNP

# SPU Series

## Swivel Flat Suction Cup

AIRBEST



WOOD



METAL SHEET



CURVED SURFACE



### Features

- ◇ With support structure at the bottom
- ◇ Small inner volume
- ◇ Available in various sizes



### Advantages

- ◇ Be able to prevent thin walled workpieces from permanent deformation
- ◇ Suitable for workpieces of various sizes and shapes



### Applications

- ◇ Suitable for handling of workpieces with inclined surface. Its mounting inner cavity is large and it can be connected with swivel joint
- ◇ Suitable for handling sheet metal or wood plate. During handling process, when it is depressed in the middle or dooping at both ends, suction cup with swivel joint can have good contact with workpiece and prevent workpiece from falling off

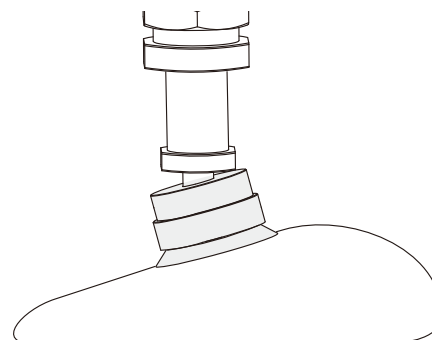

### Structure

- ◇ Split structure design for easy replacement of wearing parts

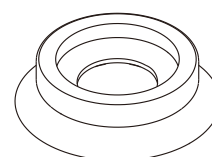
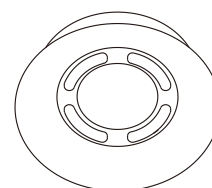

# SPU Series

## Swivel Flat Suction Cup

### How to order

## SPU 30 N

① ② ③

① Series	② Diameter	③ Material & Hardness
SPU	10 - $\phi$ 10mm	40 - $\phi$ 40mm
	15 - $\phi$ 15mm	50 - $\phi$ 50mm
	20 - $\phi$ 20mm	60 - $\phi$ 60mm
	25 - $\phi$ 25mm	80 - $\phi$ 80mm
	30 - $\phi$ 30mm	100 - $\phi$ 100mm
	35 - $\phi$ 35mm	
		N - NBR <span style="border: 1px solid black; padding: 0 2px;">55</span>
		WS - White silicone <span style="border: 1px solid black; padding: 0 2px;">50</span>

### Technical parameters

Model	Pull-out force N	Inner volume cm <sup>3</sup>	Weight g	Recommended hose dia. mm	MPQ pcs
SPU10	3.5	< 0.1	0.2	4	10
SPU15	8	0.2	0.3	6	10
SPU20	15	0.5	1.3	6	5
SPU25	24	1.1	1.5	6	5
SPU30	32	1	1.9	6	5
SPU35	43	2.4	2.5	6	5
SPU40	60	3.4	3.8	6	1
SPU50	92	5.7	5.1	8	1
SPU60	127	11	12.4	8	1
SPU80	226	25.3	24.2	8	1
SPU100	355	38	40.2	10	1

◇ Note: Testing vacuum level -60kPa, workpiece with smooth and clean surface. The data of pull-out force as above are figured out without considering safety factor. The data may be different according to different workpiece surfaces. Recommend the length of vacuum hose to be as short as possible, max 2m.

### Dimensions(mm)

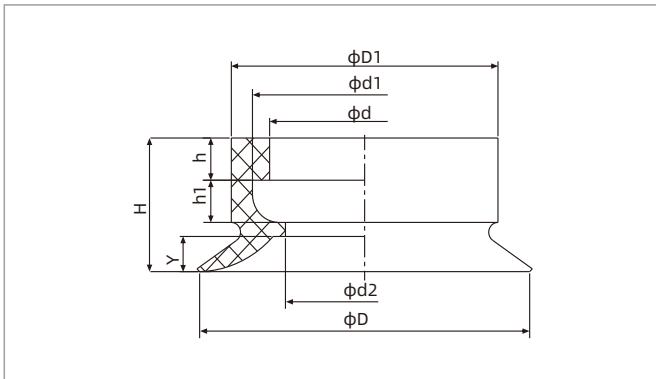

Model/Size	D	H	D1	d	h	d1	h1	d2	Y
SPU10□	10	3.5	10.5	6.5	1.5	8	0.5	4	1
SPU15□	15	4.5	10.5	6.5	1.5	8	0.5	4	1.4
SPU20□	20	9	20.2	14.4	3	17	3	12	2
SPU25□	25	9.5	20.2	14.4	3	17	3	12	2.5

SPU10-25

# SPU Series

## Swivel Flat Suction Cup

### Dimensions(mm)

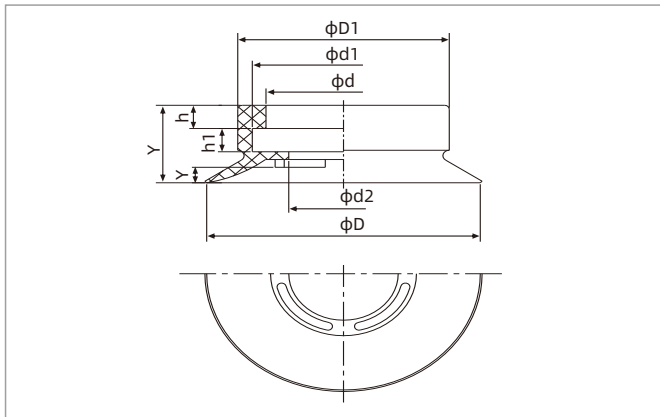

Model/Size	D	H	D1	d	h	d1	h1	d2	γ
SPU30□	30	10	23.2	17	3	20	3	12	2
SPU35□	35	11	23.2	17	3	20	3	12	3
SPU40□	40	10.5	32.2	24.5	3.5	28	2	16	3
SPU50□	50	11.5	32.2	24.5	3.5	28	2	16	4
SPU60□	60	16.2	46.2	38.5	5.2	42	3	10	5
SPU80□	80	18.2	60.2	49	5.2	54	3	10	6
SPU100□	100	18.2	78.2	66	5.2	72	3	10	6

SPU30-100

◇ Note: The dimensional tolerance conforms to GBT 3672.1-2002-1 M3 rubber product dimensional tolerance standard

# SH Series

## Heavy Load Flat Suction Cup

**AIRBEST**



Suction Cup

### Features

- ◇ Large area support structure at the bottom
- ◇ Flat and short compressed stroke
- ◇ Split structure design
- ◇ Available in various sizes

### Advantages

- ◇ Be able to prevent permanent deformation of workpieces
- ◇ Handling of workpieces with flat surface and short working cycle
- ◇ Wearing parts can be replaced, and suction cup can be recycled to highly reduce cost
- ◇ Suitable for various workpieces



### Applications

- ◇ Handling of large workpieces with flat or slightly rough surface, such as wood boards, steel plates and heavy workpieces

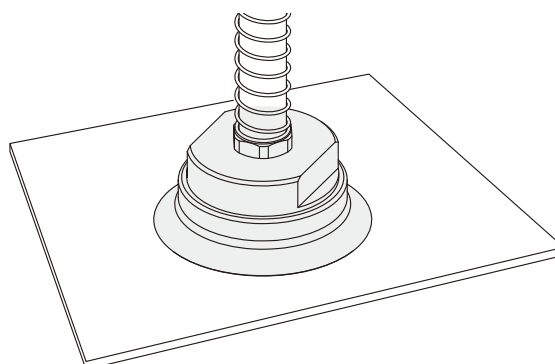

### Structure

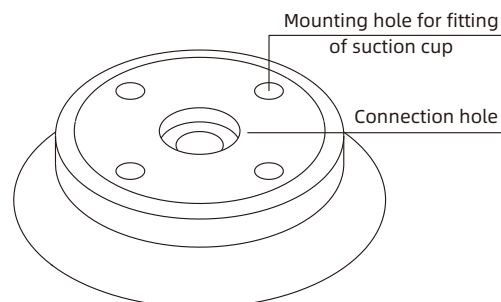

- SZ
- SPH
- SP3
- SUF
- SAN
- SAO
- SOFA
- STP
- SFT
- SFA
- SBT
- SBL
- SBLP
- SBS
- SFP
- SBP
- SXP
- SGP
- SBOF
- STC
- SFF
- SOB
- SOE
- SOG
- SFM
- SOM
- SBF
- SDM
- SFU
- SFK
- SHT
- SDL
- SFG
- SFGT
- SFD
- SB
- SBA
- SF
- SU
- SP2F
- SPA
- SPD
- SPF
- SPC
- SPJ
- SPU
- SH**
- SHB
- SBB
- SOP
- SNP

# SH Series

## Heavy Load Flat Suction Cup

### How to order

## SH 40 N

① ② ③

① Series	② Diameter		③ Material & Hardness	
SH	40 - $\phi$ 40mm	80 - $\phi$ 80mm	N - NBR	<b>55</b>
	50 - $\phi$ 50mm	100 - $\phi$ 100mm	WS - White silicone	<b>50</b>
	63 - $\phi$ 63mm	125 - $\phi$ 125mm		

### Technical parameters

Model	Pull-out force N	Inner volume cm <sup>3</sup>	Weight g	Recommended hose dia. mm	MPQ pcs
SH40	56	4	13.5	8	1
SH50	88	6.9	25.1	8	1
SH63	140	11.5	47.9	8	1
SH80	226	24	75.4	8	1
SH100	353	55	149.7	10	1
SH125	552	85	263.6	10	1

◇ Note: Testing vacuum level -60kPa, workpiece with smooth and clean surface. The data of pull-out force as above are figured out without considering safety factor. The data may be different according to different workpiece surfaces. Recommend the length of vacuum hose to be as short as possible, max 2m.

### Dimensions(mm)

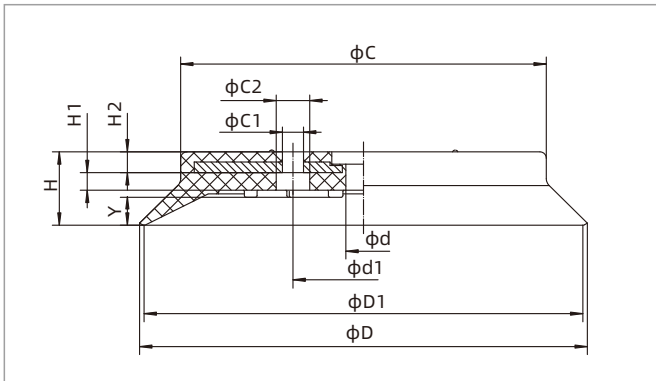

SH40-125

Model/Size	D	D1	d	d1	H	H1	H2	C	C1	C2	Y
SH40□	42	40	6	18	11.5	3.5	3.5	32	3- $\phi$ 4	3- $\phi$ 6.5	3.5
SH50□	52	50	6	18	11.5	3.5	3.5	42	3- $\phi$ 4	3- $\phi$ 6.5	3.5
SH63□	65	63	8	34	14.5	4.5	4.5	51	4- $\phi$ 5	4- $\phi$ 8	3.5
SH80□	82	80	8	34	16.5	4.5	4.5	68	4- $\phi$ 5	4- $\phi$ 8	4.5
SH100□	103	100	10	40	21	5	6	80	4- $\phi$ 6	4- $\phi$ 9.5	7.5
SH125□	127	125	10	40	21	5	6	104	4- $\phi$ 6	4- $\phi$ 9.5	7.5

◇ Note: The dimensional tolerance conforms to GBT3672.1-2002-1 M3 rubber product dimensional tolerance standard

# SH Series

## Suction Cup with Locking Fitting

### Structure

- ◇ Consisting of suction cup and locking fitting, 3 types of connection
- ◇ FIG.1: Vertical vacuum port, female thread connection
- ◇ FIG.2: Vertical vacuum port, male thread connection
- ◇ FIG.3: Lateral vacuum port, female thread connection



### How to order

SH50N - LR1 - M10F  
 ①                      ②                      ③

① Model	② Vacuum port direction	③ Connection thread
SH50N	Nil - Vertical, female thread connection R1 - Vertical, male thread connection LR1 - Lateral, female thread connection	M10F - M10×1.5 female thread M12F - M12×1.75 female thread G2F - G1/4 female thread G3F - G3/8 female thread M14M - M14×1 male thread M16M - M16×1.5 male thread

◇ Please refer to page 342 for suction cup selection

### Selection

Model	Vacuum port direction			
	Nil		R1	LR1
SH40□	SH40□-M10F	SH40□-G2F	SH40□-R1-M14M	SH40□-LR1-M10F
SH50□	SH50□-M10F	SH50□-G2F	SH50□-R1-M14M	SH50□-LR1-M10F
SH63□	SH63□-M10F	SH63□-G2F	SH63□-R1-M16M	SH63□-LR1-M10F
SH80□	SH80□-M10F	SH80□-G2F	SH80□-R1-M16M	SH80□-LR1-M10F
SH100□	SH100□-M12F	SH100□-G3F	SH100□-R1-M16M	SH100□-LR1-M10F
SH125□	SH125□-M12F	SH125□-G3F	SH125□-R1-M16M	SH125□-LR1-M10F

- SZ
- SPH
- SP3
- SUF
- SAN
- SAO
- SOFA
- STP
- SFT
- SFA
- SBT
- SBL
- SBLP
- SBS
- SFP
- SBP
- SXP
- SGP
- SBOF
- STC
- SFF
- SOB
- SOE
- SOG
- SFM
- SOM
- SBF
- SDM
- SFU
- SFK
- SHT
- SDL
- SFG
- SFGT
- SFD
- SB
- SBA
- SF
- SU
- SP2F
- SPA
- SPD
- SPF
- SPC
- SPJ
- SPU
- SH**
- SHB
- SBB
- SOP
- SNP

# SH Series

## Suction Cup with Locking Fitting

### Dimensions(mm)

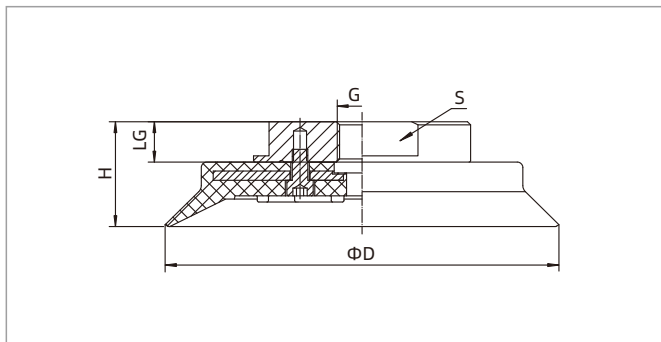

SH40-125 Vertical, female thread connection

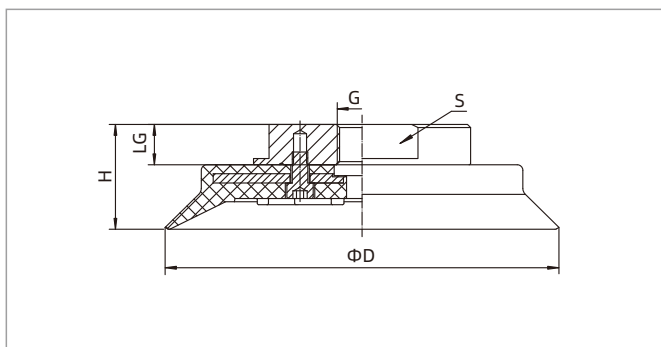

SH40-125 Vertical, female thread connection

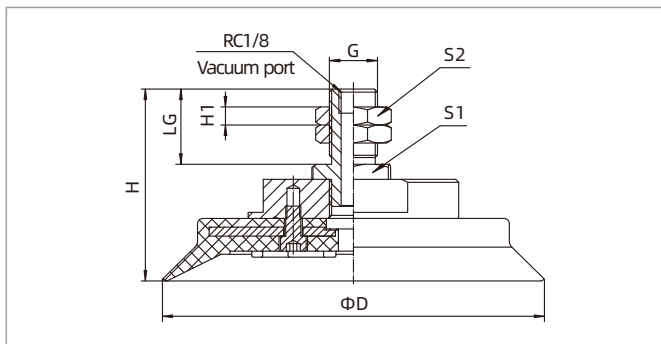

SH40-125 Vertical, male thread connection

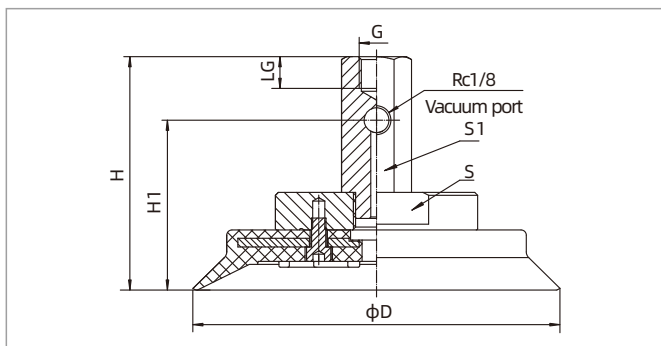

SH40-125 Lateral, female thread connection

Model/Size	D	H	G	LG	S
SH40□-G2F	42	23	G1/4	11.5	24
SH50□-G2F	52	23	G1/4	11.5	24
SH63□-G2F	65	26	G1/4	11.5	37
SH80□-G2F	82	28	G1/4	11.5	37
SH100□-G3F	103	34	G3/8	13	60
SH125□-G3F	127	34	G3/8	13	60

Model/Size	D	H	G	LG	S
SH40□-M10F	42	23	M10×1.5	11.5	24
SH50□-M10F	52	23	M10×1.5	11.5	24
SH63□-M10F	65	26	M10×1.5	11.5	37
SH80□-M10F	82	28	M10×1.5	11.5	37
SH100□-M12F	103	34	M12×1.75	13	60
SH125□-M12F	127	34	M12×1.75	13	60

Model/Size	D	H	H1	G	LG	S1	S2
SH40□-R1-M14M	42	53	5	M14×1	25	19	19
SH50□-R1-M14M	52	53	5	M14×1	25	19	19
SH63□-R1-M16M	65	56	6	M16×1.5	25	24	22
SH80□-R1-M16M	82	58	6	M16×1.5	25	24	22
SH100□-R1-M16M	103	64	6	M16×1.5	25	24	22
SH125□-R1-M16M	127	64	6	M16×1.5	25	24	22

Model/Size	D	H	H1	G	LG	S1	S2
SH40□-LR1-M10F	42	60	38	M10×1.5	11	24	21
SH50□-LR1-M10F	52	60	38	M10×1.5	11	24	21
SH63□-LR1-M10F	65	63	41	M10×1.5	11	37	21
SH80□-LR1-M10F	82	65	43	M10×1.5	11	37	21
SH100□-LR1-M10F	103	71	49	M10×1.5	11	60	21
SH125□-LR1-M10F	127	71	49	M10×1.5	11	60	21

# SH Series

## Suction Cup with Level Compensator

### Structure

- ◇ Consisting of suction cup and level compensator, 2 types of vacuum connection
- ◇ External spring and 2pcs mounting nuts
- ◇ Vacuum port connection: Rc1/8 female thread
- ◇ FIG.1 vertical vacuum port, FIG.2 lateral vacuum port



FIG.1

FIG.2

### How to order

SH50N - E 25 LR1 - M18

①                      ②      ③                      ④                      ⑤

① Model	② Buffer type	③ Buffer stroke	④ Vacuum port direction	⑤ Mounting thread
SH50N	E - External spring	25	Nil - Vertical	M18 - M18×1.5
		50	LR1 - Lateral	M22 - M22×1.5
		75		
		100		

◇ Please refer to page 342 for suction cup selection

### Selection-Vertical direction

Model	Buffer stroke			
	25	50	75	100
SH40□	SH40□-E25-M18	SH40□-E50-M18	SH40□-E75-M18	-
SH50□	SH50□-E25-M18	SH50□-E50-M18	SH50□-E75-M18	-
SH63□	SH63□-E25-M18	SH63□-E50-M18	SH63□-E75-M18	-
SH80□	SH80□-E25-M18	SH80□-E50-M18	SH80□-E75-M18	-
SH100□	SH100□-E25-M22	SH100□-E50-M22	SH100□-E75-M22	SH100□-E100-M22
SH125□	SH125□-E25-M22	SH125□-E50-M22	SH125□-E75-M22	SH125□-E100-M22

### Selection-Lateral direction

Model	Buffer stroke			
	25	50	75	100
SH40□	SH40□-E25LR1-M18	SH40□-E50LR1-M18	SH40□-E75LR1-M18	-
SH50□	SH50□-E25LR1-M18	SH50□-E50LR1-M18	SH50□-E75LR1-M18	-
SH63□	SH63□-E25LR1-M18	SH63□-E50LR1-M18	SH63□-E75LR1-M18	-
SH80□	SH80□-E25LR1-M18	SH80□-E50LR1-M18	SH80□-E75LR1-M18	-
SH100□	SH100□-E25LR1-M22	SH100□-E50LR1-M22	SH100□-E75LR1-M22	SH100□-E100LR1-M22
SH125□	SH125□-E25LR1-M22	SH125□-E50LR1-M22	SH125□-E75LR1-M22	SH125□-E100LR1-M22

- SZ
- SPH
- SP3
- SUF
- SAN
- SAO
- SOFA
- STP
- SFT
- SFA
- SBT
- SBL
- SBLP
- SBS
- SFP
- SBP
- SXP
- SGP
- SBOF
- STC
- SFF
- SOB
- SOE
- SOG
- SFM
- SOM
- SBF
- SDM
- SFU
- SFK
- SHT
- SDL
- SFG
- SFGT
- SFD
- SB
- SBA
- SF
- SU
- SP2F
- SPA
- SPD
- SPF
- SPC
- SPJ
- SPU
- SH
- SHB
- SBB
- SOP
- SNP

# SH Series

## Suction Cup with Level Compensator

### Dimensions(mm)

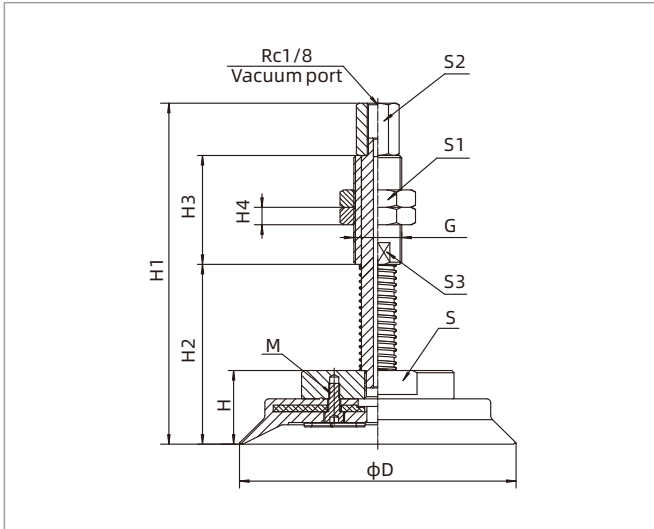

SH40-125 Vertical direction

Model/Size	D	H	H1	H2	H3	H4	G	M	S	S1	S2	S3
SH40□-E25-M18	42	23	118.5	63	35	6	M18×1.5	3-M3	24	27	14	16
SH40□-E50-M18	42	23	153.5	98	35	6	M18×1.5	3-M3	24	27	14	16
SH40□-E75-M18	42	23	189.5	134	35	6	M18×1.5	3-M3	24	27	14	16
SH50□-E25-M18	52	23	118.5	63	35	6	M18×1.5	3-M3	24	27	14	16
SH50□-E50-M18	52	23	153.5	98	35	6	M18×1.5	3-M3	24	27	14	16
SH50□-E75-M18	52	23	189.5	134	35	6	M18×1.5	3-M3	24	27	14	16
SH63□-E25-M18	65	26	121.5	66	35	6	M18×1.5	4-M4	37	27	14	16
SH63□-E50-M18	65	26	156.5	101	35	6	M18×1.5	4-M4	37	27	14	16
SH63□-E75-M18	65	26	192.5	137	35	6	M18×1.5	4-M4	37	27	14	16
SH80□-E25-M18	82	28	123.5	68	35	6	M18×1.5	4-M4	37	27	14	16
SH80□-E50-M18	82	28	158.5	103	35	6	M18×1.5	4-M4	37	27	14	16
SH80□-E75-M18	82	28	194.5	139	35	6	M18×1.5	4-M4	37	27	14	16
SH100□-E25-M22	103	34	152	78	50	8	M22×1.5	4-M5	60	30	17	19
SH100□-E50-M22	103	34	188	114	50	8	M22×1.5	4-M5	60	30	17	19
SH100□-E75-M22	103	34	228	154	50	8	M22×1.5	4-M5	60	30	17	19
SH100□-E100-M22	103	34	263	189	50	8	M22×1.5	4-M5	60	30	17	19
SH125□-E25-M22	127	34	152	78	50	8	M22×1.5	4-M5	60	30	17	19
SH125□-E50-M22	127	34	188	114	50	8	M22×1.5	4-M5	60	30	17	19
SH125□-E75-M22	127	34	228	154	50	8	M22×1.5	4-M5	60	30	17	19
SH125□-E100-M22	127	34	263	189	50	8	M22×1.5	4-M5	60	30	17	19

# SH Series

## Suction Cup with Level Compensator

### Dimensions(mm)

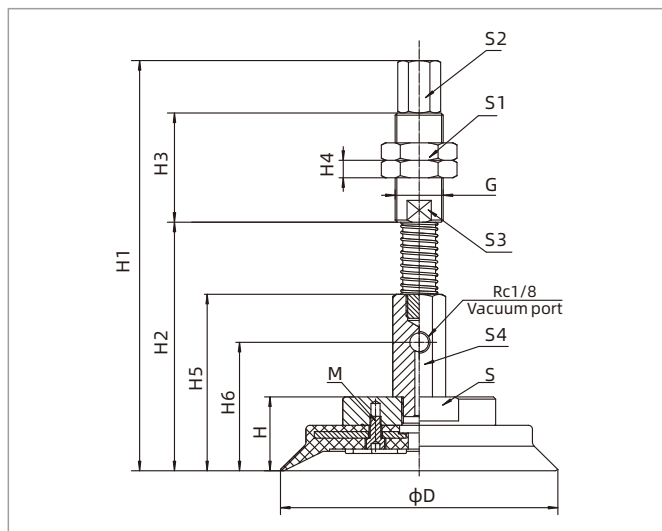

SH40-125 Lateral direction

Model/Size	D	H	H1	H2	H3	H4	H5	H6	G	M	S	S1	S2	S3	S4
SH40□-E25LR1-M18	42	23	151	100	35	6	60	38	M18×1.5	3-M3	24	27	14	16	21
SH40□-E50LR1-M18	42	23	186	135	35	6	60	38	M18×1.5	3-M3	24	27	14	16	21
SH40□-E75LR1-M18	42	23	222	171	35	6	60	38	M18×1.5	3-M3	24	27	14	16	21
SH50□-E25LR1-M18	52	23	151	100	35	6	60	38	M18×1.5	3-M3	24	27	14	16	21
SH50□-E50LR1-M18	52	23	186	135	35	6	60	38	M18×1.5	3-M3	24	27	14	16	21
SH50□-E75LR1-M18	52	23	222	171	35	6	60	38	M18×1.5	3-M3	24	27	14	16	21
SH63□-E25LR1-M18	65	26	154	103	35	6	63	41	M18×1.5	4-M4	37	27	14	16	21
SH63□-E50LR1-M18	65	26	189	136	35	6	63	41	M18×1.5	4-M4	37	27	14	16	21
SH63□-E75LR1-M18	65	26	225	172	35	6	63	41	M18×1.5	4-M4	37	27	14	16	21
SH80□-E25LR1-M18	82	28	156	105	35	6	63	41	M18×1.5	4-M4	37	27	14	16	21
SH80□-E50LR1-M18	82	28	191	138	35	6	63	41	M18×1.5	4-M4	37	27	14	16	21
SH80□-E75LR1-M18	82	28	227	174	35	6	63	41	M18×1.5	4-M4	37	27	14	16	21
SH100□-E25LR1-M22	103	34	186	115	50	8	71	49	M22×1.5	4-M5	60	30	17	19	21
SH100□-E50LR1-M22	103	34	222	151	50	8	71	49	M22×1.5	4-M5	60	30	17	19	21
SH100□-E75LR1-M22	103	34	262	191	50	8	71	49	M22×1.5	4-M5	60	30	17	19	21
SH100□-E100LR1-M22	103	34	297	226	50	8	71	49	M22×1.5	4-M5	60	30	17	19	21
SH125□-E25LR1-M22	127	34	186	115	50	8	71	49	M22×1.5	4-M5	60	30	17	19	21
SH125□-E50LR1-M22	127	34	222	151	50	8	71	49	M22×1.5	4-M5	60	30	17	19	21
SH125□-E75LR1-M22	127	34	262	191	50	8	71	49	M22×1.5	4-M5	60	30	17	19	21
SH125□-E100LR1-M22	127	34	297	226	50	8	71	49	M22×1.5	4-M5	60	30	17	19	21

- SZ
- SPH
- SP3
- SUF
- SAN
- SAO
- SOFA
- STP
- SFT
- SFA
- SBT
- SBL
- SBLP
- SBS
- SFP
- SBP
- SXP
- SGP
- SBOF
- STC
- SFF
- SOB
- SOF
- SOG
- SFM
- SOM
- SBF
- SDM
- SFU
- SFK
- SHT
- SDL
- SFG
- SFGT
- SFD
- SB
- SBA
- SF
- SU
- SP2F
- SPA
- SPD
- SPF
- SPC
- SPJ
- SPU
- SH
- SHB
- SBB
- SOP
- SNP

# SHB Series

## Heavy Load Bellows Suction Cup



METAL SHEET



WOOD



HEAVY LOAD CURVED SURFACE



### Features

- ◇ 1.5 bellows
- ◇ Split structure design
- ◇ Available in various sizes

### Advantages

- ◇ Contacting perfectly with unven surface of workpieces and good buffering
- ◇ Wearing parts can be replaced, and suction cup can be recycled to highly reduce cost
- ◇ Suitable for workpieces of various sizes and shapes

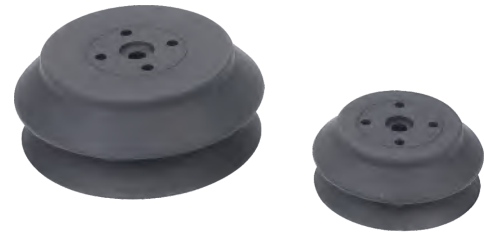

### Applications

- ◇ Handling of large workpieces with unven and irregular surface, such as wood boards, steel plates and heavy workpieces

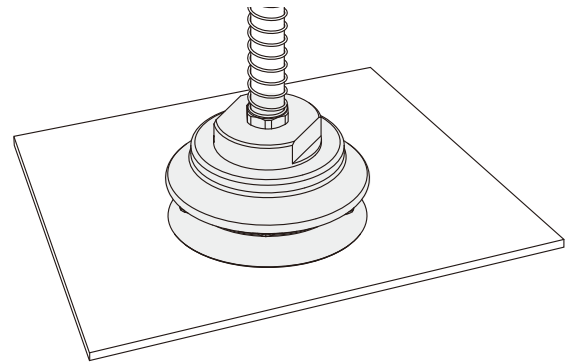

### Structure

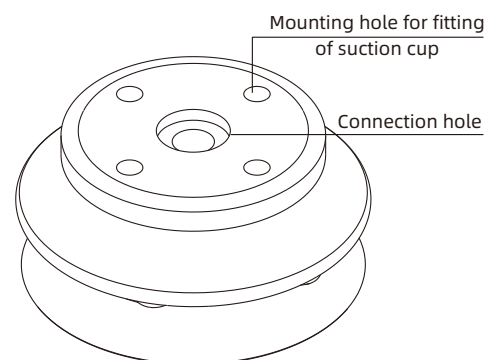

# SHB Series

## Heavy Load Bellows Suction Cup

### How to order

## SHB 40 N

① ② ③

① Series	② Diameter		③ Material & Hardness	
SHB	40 - $\phi$ 40mm	80 - $\phi$ 80mm	N - NBR	<b>55</b>
	50 - $\phi$ 50mm	100 - $\phi$ 100mm	WS - White silicone	<b>50</b>
	63 - $\phi$ 63mm	125 - $\phi$ 125mm		

### Technical parameters

Model	Pull-out force N	Inner volume cm <sup>3</sup>	Weight g	Recommended hose dia. mm	MPQ pcs
SHB40	56	15	16.1	8	1
SHB50	88	27	30	8	1
SHB63	140	45	57.9	8	1
SHB80	226	98	75.3	8	1
SHB100	353	240	197.9	10	1
SHB125	552	384	379.6	10	1

◇ Note: Testing vacuum level -60kPa, workpiece with smooth and clean surface. The data of pull-out force as above are figured out without considering safety factor. The data may be different according to different workpiece surfaces. Recommend the length of vacuum hose to be as short as possible, max 2m.

### Dimensions(mm)

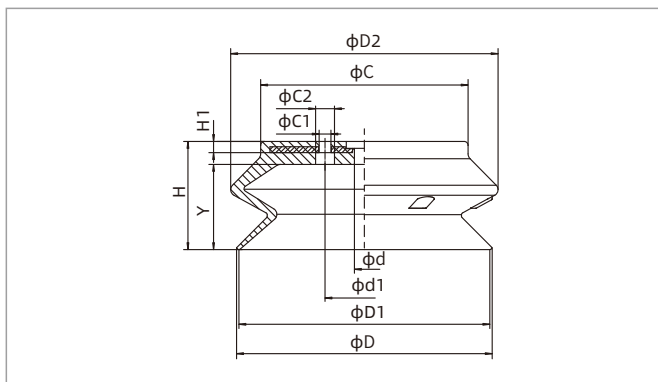

SHB40-125

Model/Size	D	D1	D2	d	d1	H	H1	C	C1	C2	Y
SHB40□	41.5	40	43.2	6	18	20.5	3.5	30	3- $\phi$ 4	3- $\phi$ 6.5	13
SHB50□	52	50	54	6	18	24	3.5	40.5	3- $\phi$ 4	3- $\phi$ 6.5	16.5
SHB63□	65	63	67.5	8	34	31.5	4.5	50	4- $\phi$ 5	4- $\phi$ 8	21.5
SHB80□	83	80	85	8	34	37	5	64	4- $\phi$ 5	4- $\phi$ 8	27.5
SHB100□	103	100	106.5	10	40	47.5	6	80	4- $\phi$ 6	4- $\phi$ 9.5	35.5
SHB125□	128.5	125	135	10	40	56	6	105	4- $\phi$ 6	4- $\phi$ 9.5	44

◇ Note: The dimensional tolerance conforms to the GB/T 3672.1-2002-1 M3 rubber product dimensional tolerance standard

# SHB Series

## Suction Cup with Locking Fitting

### Structure

- ◇ Consisting of suction cup and locking fitting, 3 types of connection
- ◇ FIG.1: Vertical vacuum port, female thread connection
- ◇ FIG.2: Vertical vacuum port, male thread connection
- ◇ FIG.3: Lateral vacuum port, female thread connection



### How to order

SHB50N - LR1 - M10F  
①      ②      ③

① Model	② Vacuum port direction	③ Connection thread
SHB50N	Nil - Vertical, female thread connection R1 - Vertical, male thread connection LR1 - Lateral, female thread connection	M10F - M10×1.5 female thread M12F - M12×1.75 female thread G2F - G1/4 female thread G3F - G3/8 female thread M14M - M14×1 male thread M16M - M16×1.5 male thread

◇ Please refer to page 349 for suction cup selection

### Selection

Model	Vacuum port direction		
	Nil	R1	LR1
SHB40□	SHB40□-M10F    SHB40□-G2F	SHB40□-R1-M14M	SHB40□-LR1-M10F
SHB50□	SHB50□-M10F    SHB50□-G2F	SHB50□-R1-M14M	SHB50□-LR1-M10F
SHB63□	SHB63□-M10F    SHB63□-G2F	SHB63□-R1-M16M	SHB63□-LR1-M10F
SHB80□	SHB80□-M10F    SHB80□-G2F	SHB80□-R1-M16M	SHB80□-LR1-M10F
SHB100□	SHB100□-M12F    SHB100□-G3F	SHB100□-R1-M16M	SHB100□-LR1-M10F
SHB125□	SHB125□-M12F    SHB125□-G3F	SHB125□-R1-M16M	SHB125□-LR1-M10F

# SHB Series

## Suction Cup with Locking Fitting

### Dimensions(mm)

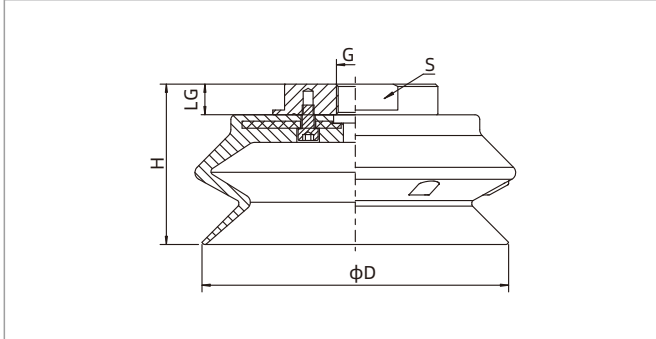

SHB40-125 Vertical, female thread connection

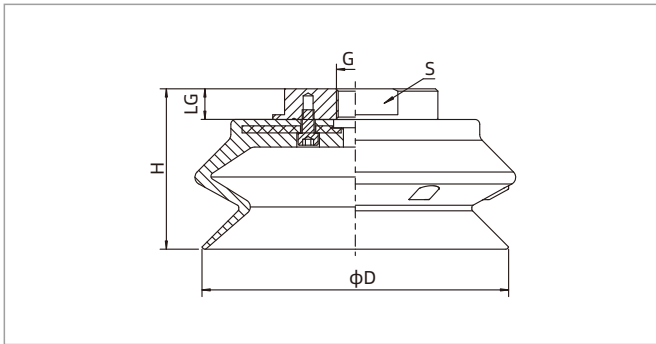

SHB40-125 Vertical, female thread connection

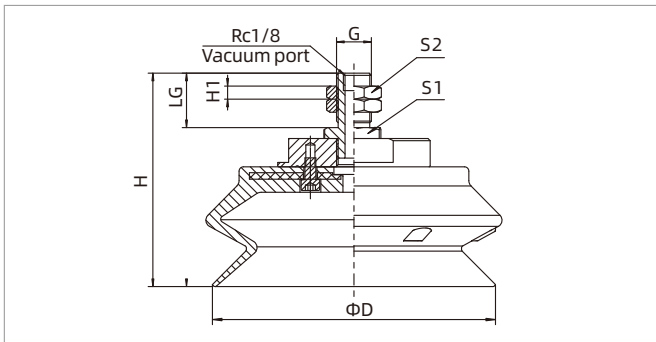

SHB40-125 Vertical, male thread connection

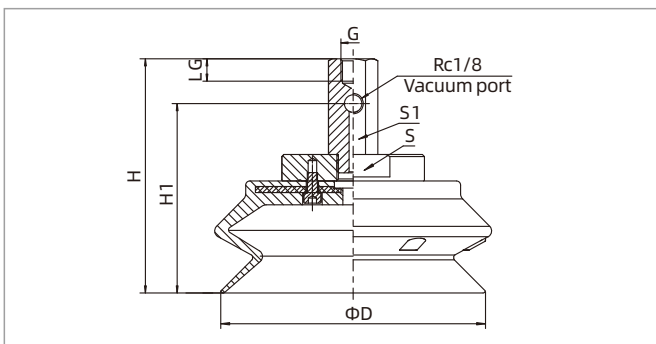

SHB40-125 Lateral, female thread connection

Model/Size	D	H	G	LG	S
SHB40□-G2F	41.5	32	G1/4	11.5	24
SHB50□-G2F	52	35.5	G1/4	11.5	24
SHB63□-G2F	65	43	G1/4	11.5	37
SHB80□-G2F	83	48.5	G1/4	11.5	37
SHB100□-G3F	103	60.5	G3/8	13	60
SHB125□-G3F	128.5	69	G3/8	13	60

Model/Size	D	H	G	LG	S
SHB40□-M10F	41.5	32	M10×1.5	11.5	24
SHB50□-M10F	52	35.5	M10×1.5	11.5	24
SHB63□-M10F	65	43	M10×1.5	11.5	37
SHB80□-M10F	83	48.5	M10×1.5	11.5	37
SHB100□-M12F	103	60.5	M12×1.75	13	60
SHB125□-M12F	128.5	69	M12×1.75	13	60

Model/Size	D	H	H1	G	LG	S1	S2
SHB40□-R1-M14M	41.5	62	5	M14×1	25	19	19
SHB50□-R1-M14M	52	65.5	5	M14×1	25	19	19
SHB63□-R1-M16M	65	73	6	M16×1.5	25	24	22
SHB80□-R1-M16M	83	78.5	6	M16×1.5	25	24	22
SHB100□-R1-M16M	103	90.5	6	M16×1.5	25	24	22
SHB125□-R1-M16M	128.5	99	6	M16×1.5	25	24	22

Model/Size	D	H	H1	G	LG	S	S1
SHB40□-LR1-M10F	41.5	69	47	M10×1.5	11	24	21
SHB50□-LR1-M10F	52	72.5	50.5	M10×1.5	11	24	21
SHB63□-LR1-M10F	65	80	58	M10×1.5	11	37	21
SHB80□-LR1-M10F	83	85.5	63.5	M10×1.5	11	37	21
SHB100□-LR1-M10F	103	97.5	75.5	M10×1.5	11	60	21
SHB125□-LR1-M10F	128.5	106	84	M10×1.5	11	60	21

- SZ
- SPH
- SP3
- SUF
- SAN
- SAO
- SOFA
- STP
- SFT
- SFA
- SBT
- SBL
- SBLP
- SBS
- SFP
- SBP
- SXP
- SGP
- SBOF
- STC
- SFF
- SOB
- SOF
- SOG
- SFM
- SOM
- SBF
- SDM
- SFU
- SFK
- SHT
- SDL
- SFG
- SFGT
- SFD
- SB
- SBA
- SF
- SU
- SP2F
- SPA
- SPD
- SPF
- SPC
- SPJ
- SPU
- SH
- SHB**
- SBB
- SOP
- SNP

# SHB Series

## Suction Cup with Level Compensator

### Structure

- ◇ Consisting of suction cup and level compensator, 2 types of vacuum connection
- ◇ External spring and 2pcs mounting nuts
- ◇ Vacuum port connection: Rc1/8 female thread
- ◇ FIG.1 vertical vacuum port, FIG.2 lateral vacuum port



FIG.1

FIG.2

### How to order

SHB50N - E 25 LR1 - M18

①                      ②    ③                      ④                      ⑤

① Model	② Buffer type	③ Buffer stroke	④ Vacuum port direction	⑤ Mounting thread
SHB50N	E - External spring	25	Nil - Vertical	M18 - M18×1.5
		50	LR1 - Lateral	M22 - M22×1.5
		75		
		100		

◇ Please refer to page 349 for suction cup selection

### Selection - Vertical direction

Model	Buffer stroke			
	25	50	75	100
SHB40□	SHB40□-E25-M18	SHB40□-E50-M18	SHB40□-E75-M18	-
SHB50□	SHB50□-E25-M18	SHB50□-E50-M18	SHB50□-E75-M18	-
SHB63□	SHB63□-E25-M18	SHB63□-E50-M18	SHB63□-E75-M18	-
SHB80□	SHB80□-E25-M18	SHB80□-E50-M18	SHB80□-E75-M18	-
SHB100□	SHB100□-E25-M22	SHB100□-E50-M22	SHB100□-E75-M22	SHB100□-E100-M22
SHB125□	SHB125□-E25-M22	SHB125□-E50-M22	SHB125□-E75-M22	SHB125□-E100-M22

### Selection - Lateral direction

Model	Buffer stroke			
	25	50	75	100
SHB40□	SHB40□-E25LR1-M18	SHB40□-E50LR1-M18	SHB40□-E75LR1-M18	-
SHB50□	SHB50□-E25LR1-M18	SHB50□-E50LR1-M18	SHB50□-E75LR1-M18	-
SHB63□	SHB63□-E25LR1-M18	SHB63□-E50LR1-M18	SHB63□-E75LR1-M18	-
SHB80□	SHB80□-E25LR1-M18	SHB80□-E50LR1-M18	SHB80□-E75LR1-M18	-
SHB100□	SHB100□-E25LR1-M22	SHB100□-E50LR1-M22	SHB100□-E75LR1-M22	SHB100□-E100LR1-M22
SHB125□	SHB125□-E25LR1-M22	SHB125□-E50LR1-M22	SHB125□-E75LR1-M22	SHB125□-E100LR1-M22

# SHB Series

## Suction Cup with Level Compensator

### Dimensions(mm)

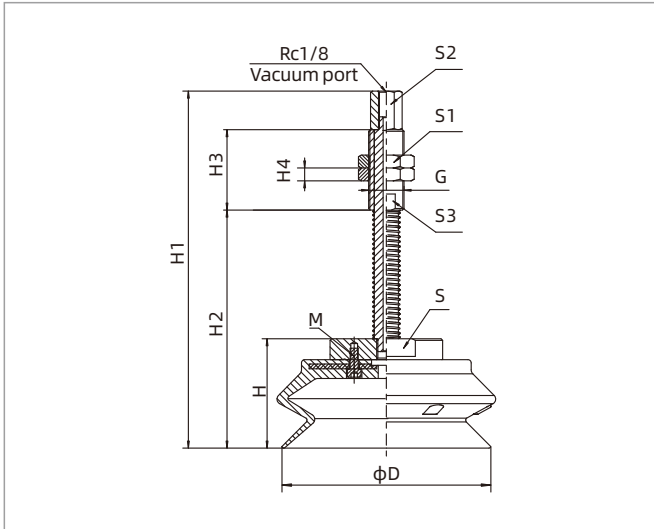

SHB40-125 Vertical direction

Model/Size	D	H	H1	H2	H3	H4	G	M	S	S1	S2	S3
SHB40□-E25-M18	41.5	32	127.5	70	35	6	M18×1.5	3-M3	24	27	14	16
SHB40□-E50-M18	41.5	32	162.5	107	35	6	M18×1.5	3-M3	24	27	14	16
SHB40□-E75-M18	41.5	32	198.5	143	35	6	M18×1.5	3-M3	24	27	14	16
SHB50□-E25-M18	52	35.5	131	75.5	35	6	M18×1.5	3-M3	24	27	14	16
SHB50□-E50-M18	52	35.5	166	110.5	35	6	M18×1.5	3-M3	24	27	14	16
SHB50□-E75-M18	52	35.5	202	146.5	35	6	M18×1.5	3-M3	24	27	14	16
SHB63□-E25-M18	65	43	138.5	83	35	6	M18×1.5	4-M4	37	27	14	16
SHB63□-E50-M18	65	43	173.5	118	35	6	M18×1.5	4-M4	37	27	14	16
SHB63□-E75-M18	65	43	209.5	154	35	6	M18×1.5	4-M4	37	27	14	16
SHB80□-E25-M18	83	48.5	144	88.5	35	6	M18×1.5	4-M4	37	27	14	16
SHB80□-E50-M18	83	48.5	179	123.5	35	6	M18×1.5	4-M4	37	27	14	16
SHB80□-E75-M18	83	48.5	215	159.5	35	6	M18×1.5	4-M4	37	27	14	16
SHB100□-E25-M22	103	60.5	178.5	104.5	50	8	M22×1.5	4-M5	60	30	17	19
SHB100□-E50-M22	103	60.5	214.5	140.5	50	8	M22×1.5	4-M5	60	30	17	19
SHB100□-E75-M22	103	60.5	254.5	180.5	50	8	M22×1.5	4-M5	60	30	17	19
SHB100□-E100-M22	103	60.5	289.5	215.5	50	8	M22×1.5	4-M5	60	30	17	19
SHB125□-E25-M22	128.5	69	187	113	50	8	M22×1.5	4-M5	60	30	17	19
SHB125□-E50-M22	128.5	69	223	149	50	8	M22×1.5	4-M5	60	30	17	19
SHB125□-E75-M22	128.5	69	263	189	50	8	M22×1.5	4-M5	60	30	17	19
SHB125□-E100-M22	128.5	69	298	224	50	8	M22×1.5	4-M5	60	30	17	19

- SZ
- SPH
- SP3
- SUF
- SAN
- SAO
- SOFA
- STP
- SFT
- SFA
- SBT
- SBL
- SBLP
- SBS
- SFP
- SBP
- SXP
- SGP
- SBOF
- STC
- SFF
- SOB
- SOF
- SOG
- SFM
- SOM
- SBF
- SDM
- SFU
- SFK
- SHT
- SDL
- SFG
- SFGT
- SFD
- SB
- SBA
- SF
- SU
- SP2F
- SPA
- SPD
- SPF
- SPC
- SPJ
- SPU
- SH
- SHB**
- SBB
- SOP
- SNP

# SHB Series

## Suction Cup with Level Compensator



### Dimensions(mm)

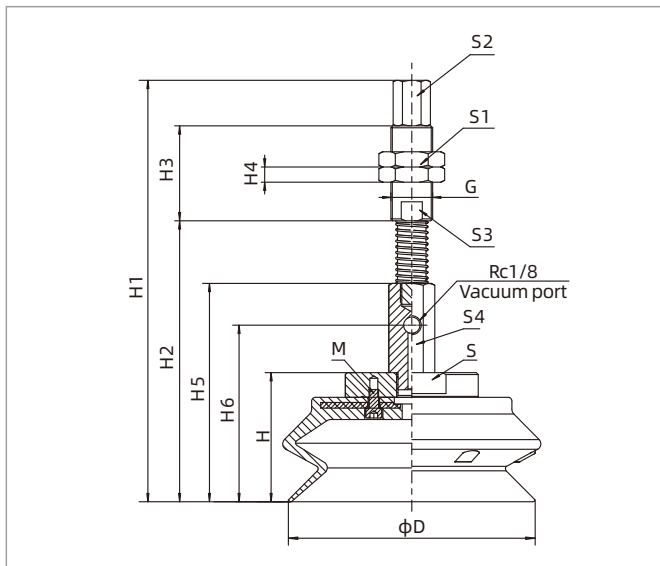

SHB40-125 Lateral direction

Model/Size	D	H	H1	H2	H3	H4	H5	H6	G	M	S	S1	S2	S3	S4
SHB40□-E25LR1-M18	41.5	32	160	109	35	6	69	47	M18×1.5	3-M3	24	27	14	16	21
SHB40□-E50LR1-M18	41.5	32	195	144	35	6	69	47	M18×1.5	3-M3	24	27	14	16	21
SHB40□-E75LR1-M18	41.5	32	231	180	35	6	69	47	M18×1.5	3-M3	24	27	14	16	21
SHB50□-E25LR1-M18	52	35.5	163.5	112.5	35	6	72.5	50.5	M18×1.5	3-M3	24	27	14	16	21
SHB50□-E50LR1-M18	52	35.5	198.5	147.5	35	6	72.5	50.5	M18×1.5	3-M3	24	27	14	16	21
SHB50□-E75LR1-M18	52	35.5	234.5	183.5	35	6	72.5	50.5	M18×1.5	3-M3	24	27	14	16	21
SHB63□-E25LR1-M18	65	43	171	120	35	6	80	58	M18×1.5	4-M4	37	27	14	16	21
SHB63□-E50LR1-M18	65	43	206	155	35	6	80	58	M18×1.5	4-M4	37	27	14	16	21
SHB63□-E75LR1-M18	65	43	242	191	35	6	80	58	M18×1.5	4-M4	37	27	14	16	21
SHB80□-E25LR1-M18	83	48.5	176.5	125.5	35	6	85.5	63.5	M18×1.5	4-M4	37	27	14	16	21
SHB80□-E50LR1-M18	83	48.5	211.5	160.5	35	6	85.5	63.5	M18×1.5	4-M4	37	27	14	16	21
SHB80□-E75LR1-M18	83	48.5	247.5	196.5	35	6	85.5	63.5	M18×1.5	4-M4	37	27	14	16	21
SHB100□-E25LR1-M22	103	60.5	212.5	141.5	50	8	97.5	75.5	M22×1.5	4-M5	60	30	17	19	21
SHB100□-E50LR1-M22	103	60.5	248.5	177.5	50	8	97.5	75.5	M22×1.5	4-M5	60	30	17	19	21
SHB100□-E75LR1-M22	103	60.5	288.5	217.5	50	8	97.5	75.5	M22×1.5	4-M5	60	30	17	19	21
SHB100□-E100LR1-M22	103	60.5	323.5	252.5	50	8	97.5	75.5	M22×1.5	4-M5	60	30	17	19	21
SHB125□-E25LR1-M22	128.5	69	221	150	50	8	106	84	M22×1.5	4-M5	60	30	17	19	21
SHB125□-E50LR1-M22	128.5	69	257	186	50	8	106	84	M22×1.5	4-M5	60	30	17	19	21
SHB125□-E75LR1-M22	128.5	69	297	226	50	8	106	84	M22×1.5	4-M5	60	30	17	19	21
SHB125□-E100LR1-M22	128.5	69	332	261	50	8	106	84	M22×1.5	4-M5	60	30	17	19	21

# SBB Series

## 1.5 Bellows Big Suction Cup



HEAVY LOAD



### Features

- ◇ 1.5 Bellows
- ◇ Large area pattern support structure at bottom
- ◇ Rubber parts and metal connection plate are one-piece structure
- ◇ Suction cups with large diameter

### Advantages

- ◇ Easy to fit uneven surface of workpiece, and had buffer effect
- ◇ Handling thin workpiece without permanent deformation
- ◇ It will be more reliable and stable during heavy load handling
- ◇ Suitable for handling large, heavy and vulnerable workpieces



### Applications

- ◇ Handling paper, metal sheet, wood plate, ceramic, etc.
- ◇ Handling workpieces with uneven surface

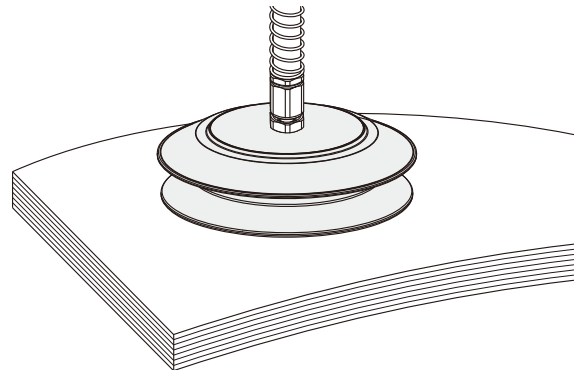

### Structure

- ◇ One-piece structure design of suction cup and fitting
- ◇ Metal connection plate of SBB200 is with G1/2 female thread connection port
- ◇ Metal connection plate of SBB250-SBB300 is without thread hole, and it is flange plate connection structure

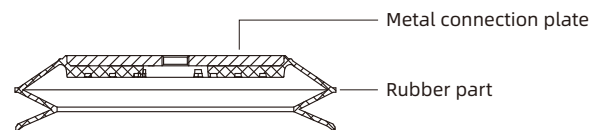

SZ  
SPH  
SP3  
SUF  
SAN  
SAO  
SOFA  
STP  
SFT  
SFA  
SBT  
SBL  
SBLP  
SBS  
SFP  
SBP  
SXP  
SGP  
SBOF  
STC  
SFF  
SOB  
SOF  
SOG  
SFM  
SOM  
SBF  
SDM  
SFU  
SFK  
SHT  
SDL  
SFG  
SFGT  
SFD  
SB  
SBA  
SF  
SU  
SP2F  
SPA  
SPD  
SPF  
SPC  
SPJ  
SPU  
SH  
SHB  
**SBB**  
SOP  
SNP

# SBB Series

## 1.5 Bellows Big Suction Cup

### How to order

## SBB 200 N - G4F

① ② ③ ④

① Series	② Diameter	③ Material & Hardness	④ Connection thread
SBB	200 - $\phi$ 200mm 250 - $\phi$ 250mm 300 - $\phi$ 300mm	N - NBR <b>60</b>	Nil - 4- $\phi$ 7 flange hole G4F - G1/2 female thread

### Selection

Model/Connection thread Nil - 4- $\phi$ 7 flange hole	F - Female thread
-	SBB200N-G4F
SBB250N	-
SBB300N	-

### Technical parameters

Model	Pull-out force N	Inner volume cm <sup>3</sup>	Min. curve radius of workpiece mm	Weight g	Recommend hose dia. mm	MPQ pcs
SBB200	850	790	350	860	12	1
SBB250	1,620	1,677	480	1,012	12	1
SBB300	2,390	2,950	580	1,650	12	1

◇ Note: Testing vacuum level -60kPa, workpiece with smooth and clean surface. The data of pull-out force as above are figured out without considering safety factor. The data may be different according to different workpiece surfaces. Recommend the length of vacuum hose to be as short as possible, max 2m.

### Dimensions(mm)

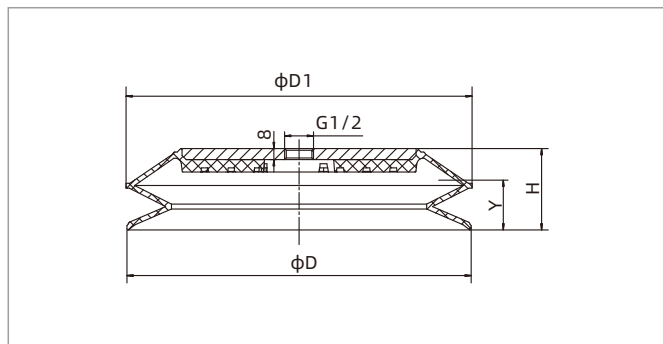

SBB200N-G4F

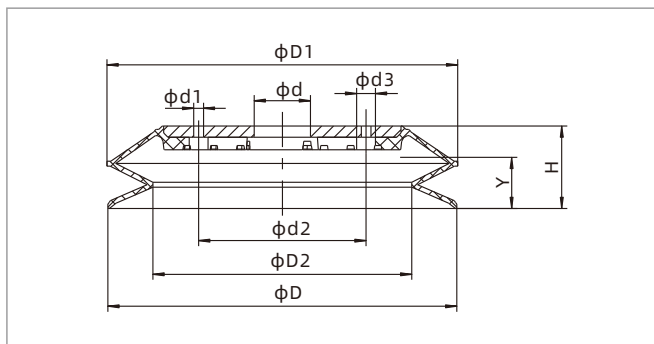

SBB□N

Model/Size	D	D1	H	d	d1	d2	d3	Y
SBB200□-G4F	200	206	57	-	-	-	-	40
SBB250□	250	251	60	40	4-7	120	4-13.5	43
SBB300□	300	306	77	40	4-7	120	4-15.5	57

◇ Note: The dimensional tolerance conforms to GBT3672.1-2002-1 M3 rubber product dimensional tolerance standard

# SOP Series

## Circular Foam Rubber Suction Cup

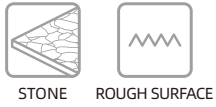

### Features

- ◇ Annular foam rubber
- ◇ Metal support plate
- ◇ NF(black) for Neoprene foam rubber, OF(orange) for Geranium foam rubber
- ◇ Available in various sizes

### Advantages

- ◇ Long lifetime, good sealing and large suction force
- ◇ Large area support plate, light weight and high load
- ◇ NF and OF material optional for different working conditions
- ◇ Suitable for workpieces of various sizes and shapes



### Applications

- ◇ Handling of workpieces with very rough or uneven surface such as buckle plate, embossed plate, marble, tile, cement board and grid metal plate
- ◇ NF for workpieces with rough surface and outdoor use. Good weather and ozone resistance, but poor in yield elasticity and not suitable for food industry.
- ◇ OF for workpieces with very rough surface. Good yield elasticity, wear resistance, tear resistance, high cut resistance and good ductility, but poor in oil resistance, heat resistance and aging resistance, not suitable for food industry.
- ◇ Do not use in water or oil environments
- ◇ It is recommended to use large flow vacuum generator
- ◇ For the use of the sponge suction cup, please refer to General Precautions on Page 24

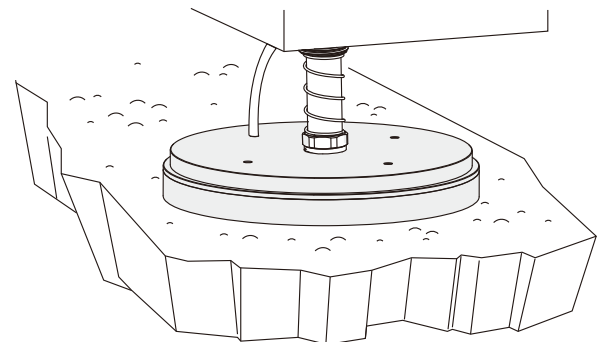

### Structure

- ◇ Consisting of metal support plate and foam rubber. Foam rubber is with gum, which can stick to the support plate directly. Foam rubber is consumable, which can be ordered separately for replacement

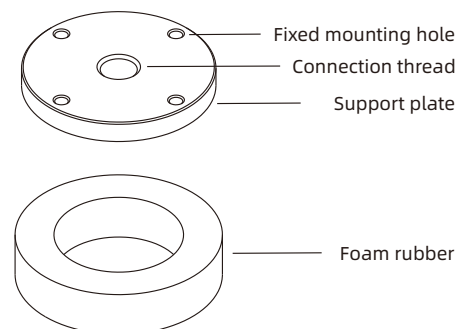

SZ  
SPH  
SP3  
SUF  
SAN  
SAO  
SOFA  
STP  
SFT  
SFA  
SBT  
SBL  
SBLP  
SBS  
SFP  
SBP  
SXP  
SGP  
SBOF  
STC  
SFF  
SOB  
SOF  
SOG  
SFM  
SOM  
SBF  
SDM  
SFU  
SFK  
SHT  
SDL  
SFG  
SFGT  
SFD  
SB  
SBA  
SF  
SU  
SP2F  
SPA  
SPD  
SPF  
SPC  
SPJ  
SPU  
SH  
SHB  
SBB  
**SOP**  
SNP

# SOP Series

## Circular Foam Rubber Suction Cup

### How to order

## SOP 64 NF - G2F

① ② ③ ④

① Series	② Diameter	③ Material	④ Connection thread
SOP	40 - $\phi$ 40mm	127 - $\phi$ 127mm	NF - Neoprene foam rubber <span style="display:inline-block; width:10px; height:10px; background-color:black;"></span>
	64 - $\phi$ 64mm	180 - $\phi$ 180mm	OF - Geranium foam rubber <span style="display:inline-block; width:10px; height:10px; background-color:orange;"></span>
	92 - $\phi$ 92mm	220 - $\phi$ 220mm	
			Nil - Foam rubber only G2F - G1/4 female thread G3F - G3/8 female thread G4F - G1/2 female thread

### Selection

Model	Connection thread G2F	G3F	G4F	MPQ pcs
SOP40□	SOP40□-G2F	-	-	1
SOP64□	SOP64□-G2F	-	-	1
SOP92□	-	SOP92□-G3F	-	1
SOP127□	-	-	SOP127□-G4F	1
SOP180□	-	-	SOP180□-G4F	1
SOP220□	-	-	SOP220□-G4F	1

### Dimensions(mm)

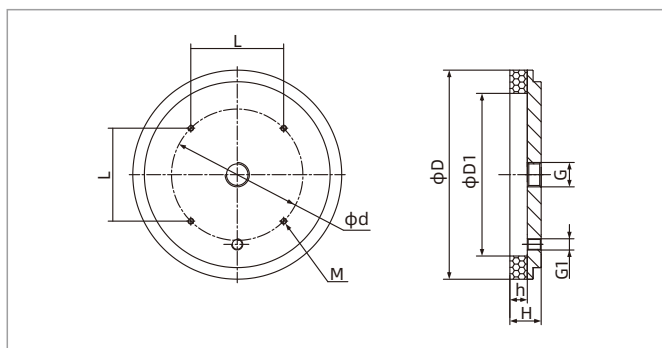

SOP40-180

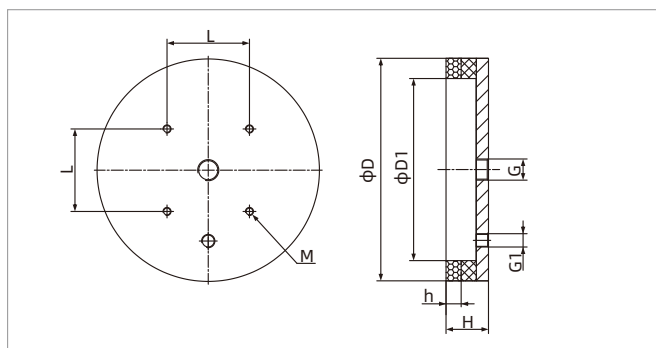

SOP220

Model/Size	D	D1	H	h	G	G1	d	L	M	Weight g	Pull-out force N
SOP40□-G2F	40	20	25	15	G1/4	-	-	-	-	34.9	7.8
SOP64□-G2F	64	40	25	15	G1/4	-	40	-	-	82.1	35
SOP92□-G3F	92	64	26	15	G3/8	-	70	-	4-M5×0.8depth6	191.1	85
SOP127□-G4F	127	92	30	15	G1/2	G1/8	-	70	4-M5×0.8depth6	482.1	175
SOP180□-G4F	180	127	27	15	G1/2	G1/8	-	80	4-M5×0.8depth6	754.1	385
SOP220□-G4F	220	180	42	15	G1/2	G1/4	-	85	4-M8×1.25depth6	1570.9	635

◇ Note: 1. Testing vacuum level -60kPa, workpiece with smooth and clean surface. The data of pull-out force as above are figured out without considering safety factor. The data may be different according to different workpiece surfaces. Recommend the length of vacuum hose to be as short as possible, max 2m.  
2. The dimensional tolerance conforms to GBT 3672.1-2002-1 M3 rubber product dimensional tolerance standard

# SNP Series

## Rectangular Foam Rubber Suction Cup

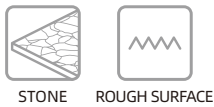

### Features

- ◇ Annular foam rubber
- ◇ Metal support plate
- ◇ NF(black) for Neoprene foam rubber, OF(orange) for Geranium foam rubber
- ◇ Available in various sizes

### Advantages

- ◇ Long lifetime, good sealing and large suction force
- ◇ Large area support plate with light weight and high load
- ◇ NF and OF material optional for different working conditions
- ◇ Suitable for workpieces of various sizes and shapes

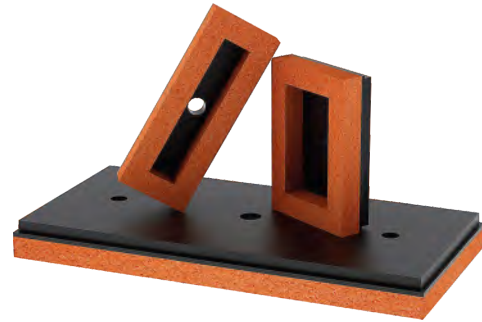

### Applications

- ◇ Handling of workpieces with very rough or uneven surface such as buckle plate, embossed plate, marble, tile, cement board and grid metal plate
- ◇ NF for workpieces with rough surface and outdoor use. Good weather and ozone resistance, but poor in yield elasticity and storage stability, not suitable for food industry
- ◇ OF for workpieces with very rough surface. Good yield elasticity, wear resistance, tear resistance, high cut resistance and good ductility, but poor in oil resistance, heat resistance and aging resistance, not suitable for food industry
- ◇ Do not use in water or oil environments
- ◇ It is recommended to use large flow vacuum generator
- ◇ For the use of the sponge suction cup, please refer to General Precautions on Page 24

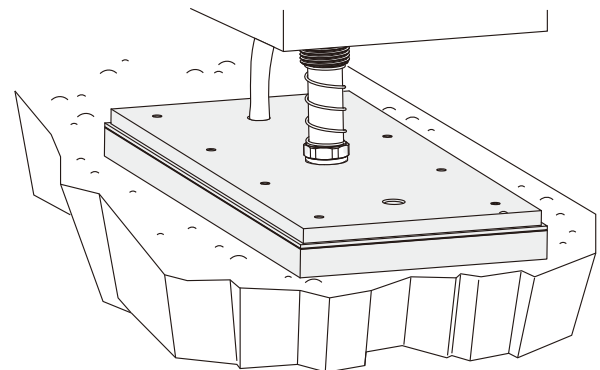

### Structure

- ◇ Consisting of metal support plate and foam rubber. Foam rubber is with gum, which can stick to the support plate directly. Foam rubber is consumable, which can be ordered separately for replacement

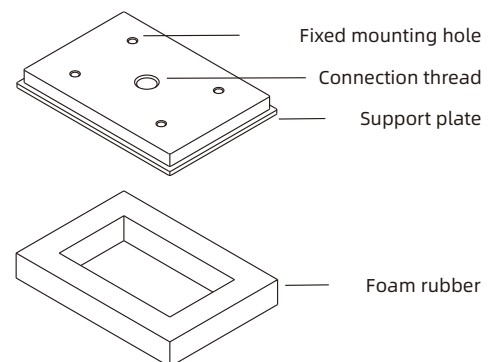

SZ  
SPH  
SP3  
SUF  
SAN  
SAO  
SOFA  
STP  
SFT  
SFA  
SBT  
SBL  
SBLP  
SBS  
SFP  
SBP  
SXP  
SGP  
SBOF  
STC  
SFF  
SOB  
SOF  
SOG  
SFM  
SOM  
SBF  
SDM  
SFU  
SFK  
SHT  
SDL  
SFG  
SFGT  
SFD  
SB  
SBA  
SF  
SU  
SP2F  
SPA  
SPD  
SPF  
SPC  
SPJ  
SPU  
SH  
SHB  
SBB  
SOP  
SNP

# SNP Series

## Rectangular Foam Rubber Suction Cup

### How to order

## SNP 50×135 NF - G2F

①                      ②                      ③                      ④

① Series	② Size	③ Material	④ Connection thread
SNP	50×135	NF - Neoprene foam rubber <span style="display:inline-block; width:10px; height:10px; background-color:black;"></span>	Nil - Foam rubber only
	60×135	OF - Geranium foam rubber <span style="display:inline-block; width:10px; height:10px; background-color:orange;"></span>	G2F - G1/4 female thread
	75×107		G3F - G3/8 female thread
	68×290		G4F - G1/2 female thread
	140×290		

### Selection

Model	Connection thread G2F	G3F	G4F	MPQ pcs
SNP50×135□	SNP50×135□-G2F	-	-	1
SNP60×135□	SNP60×135□-G2F	-	-	1
SNP75×107□	SNP75×107□-G2F	-	-	1
SNP68×290□	-	SNP68×290□-G3F	-	1
SNP140×290□	-	-	SNP140×290□-G4F	1

### Dimensions(mm)

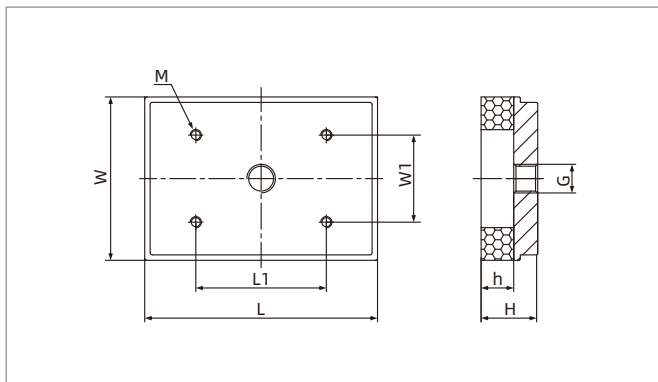

SNP50×135    SNP60×135    SNP75×107

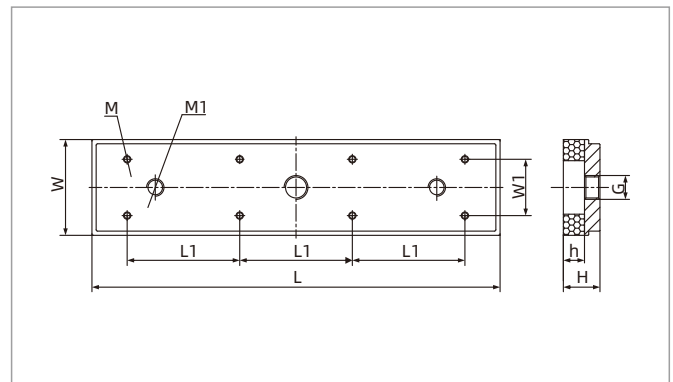

SNP68×290    SNP140×290

Model/Size	L	W	L1	W1	G	H	h	M	M1	Weight g	Pull-out force N
SNP50×135□-G2F	135	50	80	30	G1/4	26	15	4-M5×0.8depth7	-	202	60
SNP60×135□-G2F	135	60	80	40	G1/4	26	15	4-M5×0.8depth7	-	246	80
SNP75×107□-G2F	107	75	60	40	G1/4	26	15	4-M5×0.8depth7	-	234	90
SNP68×290□-G3F	290	68	80	40	G3/8	26	15	8-M5×0.8depth7	2-M12×1.75	587	250
SNP140×290□-G4F	290	140	80	100	G1/2	26	15	8-M5×0.8depth7	2-M12×1.75	1,235	720

◇ Note: 1. Testing vacuum level -60kPa, workpiece with smooth and clean surface. The data of pull-out force as above are figured out without considering safety factor. The data may be different according to different workpiece surfaces. Recommend the length of vacuum hose to be as short as possible, max 2m.  
2. The dimensional tolerance conforms to GBT 3672.1-2002-1 M3 rubber product dimensional tolerance standard

## **D** Special Vacuum Grippers

# Special Vacuum Grippers

## Products Overview

### Special Vacuum Grippers

#### 361 SLG Series

##### Magnetic Gripper

- ◇ Dia.: 20~50mm
- ◇ Air supply pressure range: 3.5~6.0bar



METAL SHEET



RoHS

#### 368 SLP Series

##### Flow Gripper

- ◇ Vacuum level: 4.5~11kPa
- ◇ Vacuum flow: 320~1,195NL/min



NEW ENERGY



BATTERY



COMPOSITE MATERIAL



POROUS



RoHS

#### 364 SNC Series

##### Needle Gripper

- ◇ QTY of Needle: 4 10
- ◇ Air consumption: 55~65bar



COMPOSITE MATERIAL



FABRIC MATERIAL



RoHS

#### 371 SLB Series

##### Thin Lip Flow Gripper

- ◇ Vacuum level: 4.5~16kPa
- ◇ Vacuum flow: 680~1,315NL/min



ELECTRONICS



NEW ENERGY



POROUS



RoHS

#### 366 SNT Series

##### Non-contact Suction Cup

- ◇ Dia.: 20~100mm
- ◇ Suction force: 2~46N



COMPOSITE MATERIAL



POROUS MATERIAL



RoHS

#### 375 SLW Series

##### Wafer Gripper

- ◇ Vacuum level: 4.5~11kPa
- ◇ Vacuum flow: 330~490NL/min



NEW ENERGY



COMPOSITE MATERIAL



POROUS



RoHS

# SLG Series

## Magnetic Gripper



### Features

- ◇ Gripping by magnetic force
- ◇ Permanent magnet for safe gripping
- ◇ Different connection thread for option
- ◇ No need of electric power

### Advantages

- ◇ Compact size, light weight, easy to install
- ◇ Solid and durable
- ◇ Anti-skid ring could be easily replaced



### Application

- ◇ Suitable for handling ferromagnetic workpieces
- ◇ Suitable for handling perforated sheet metal, complex laser cutting workpieces

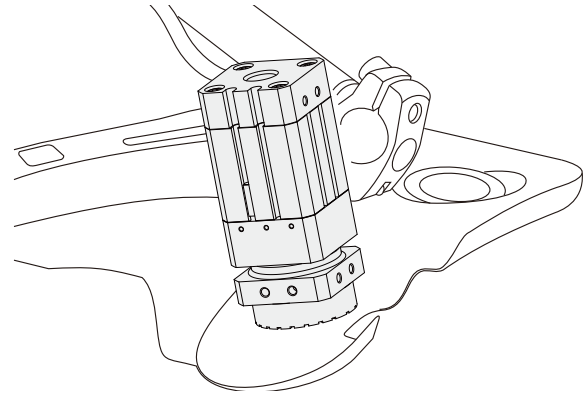

### Structure

- ◇ (1) Air supply port (grip)
- ◇ (2) Air supply port (release)
- ◇ (3) The magnetic switch
- ◇ (4) Anti-skid ring
- ◇ (5) Center threaded mounting hole
- ◇ (6) Side threaded mounting hole

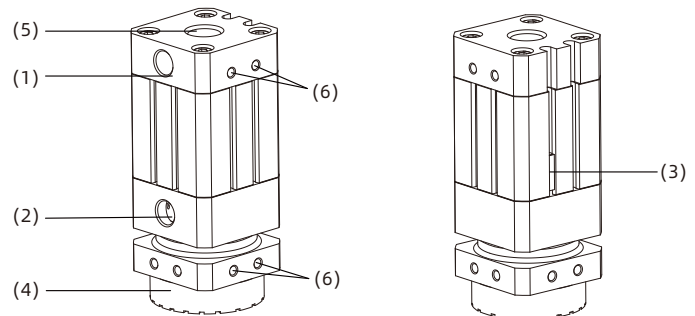

Special Vacuum Grippers

- SLG
- SNC
- SNT
- SLP
- SLB
- SLW
- SLF

# SLG Series

## Magnetic Gripper

### How to order

## SLG 40 - G1F

①      ②      ③

① Series	② Dimension	③ Connection thread
SLG	20 - φ20mm 30 - φ30mm 40 - φ40mm 50 - φ50mm	G1F - G1/8 female thread G2F - G1/4 female thread

### Selection

Model	Dia.of suction cup	Connection thread	
		G1F	G2F
SLG	20	●	-
	30	●	-
	40	-	●
	50	-	●

◇ Note: H (high temp. resistance type) cannot select magnetic switch

### Technical parameters

Model	Air supply pressure range bar	Working temperature °C	Contact temperature °C	Max. holding force N	Lateral force		Weight g
					Non oily N	Oily N	
SLG20	3.5~6.0	5~70	≤70	17	8	8	90
SLG30	3.5~6.0	5~70	≤70	85	32	23	223
SLG40	3.5~6.0	5~70	≤70	220	81	56	427
SLG50	3.5~6.0	5~70	≤70	380	105	65	795

Model	ZPDM-N	ZPDM-P
Wiring diagram		
Wiring	3 wires	
Switch	Electronic type contactless, NO type	
Output contact type	Contactless, NPN	Contactless, PNP
Voltage range	5~30V DC	
Max. switch current	80mA max.	



M8 male connection type

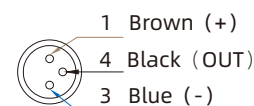

Model	Output mode	Connection type
ZPDM-N	1NPN	Outlet wire connection
ZPDM-P	1PNP	Outlet wire connection
ZPDM-N-M8	1NPN	M8 male connection
ZPDM-P-M8	1PNP	M8 male connection

# SLG Series

## Magnetic Gripper

### Dimensions(mm)

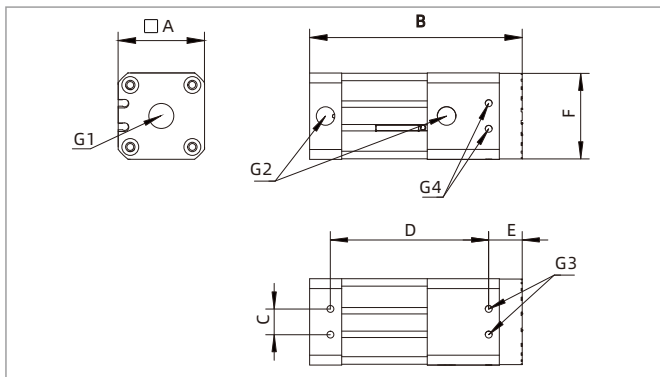

SLG Normal type

Model/Size	A	B	C	D	E	F	G1	G2	G3	G4
SLG20	20	78.2	6.5	55	13.2	20	G1/8	M5×0.8	M3×0.5	M3×0.5
SLG30	30	99.4	12	74	15.7	30	G1/8	G1/8	M4×0.7	M4×0.7
SLG40	40	99.4	12	74	15.7	40	G1/4	G1/8	M4×0.7	M4×0.7
SLG50	50	123.4	15	100	15.7	50	G1/4	G1/8	M5×0.8	M5×0.8

### Mounting brackets(mm)

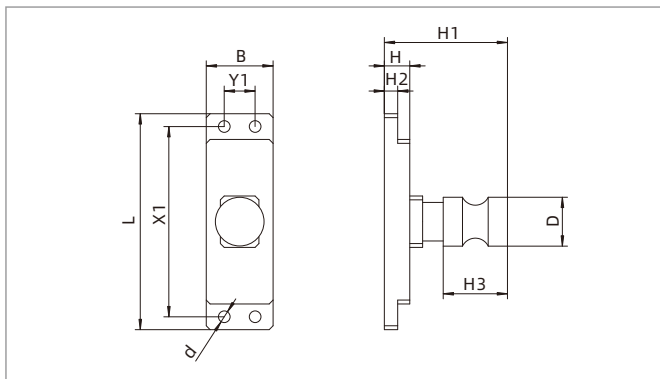

A-Columnar bracket

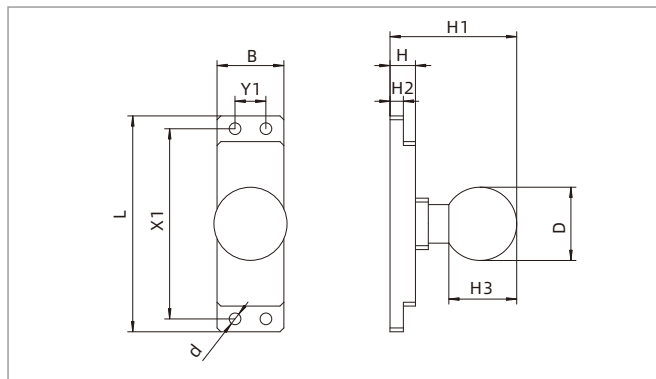

B-Spherical bracket

Model/Size	L	B	H1	D	H3	H2	H	X1	Y1	d
SLG20-A	63	15	50	19	25	5.2	9.9	55	6.5	3.4
SLG20-B	63	15	49.3	28.5	26.4	5.2	9.9	55	6.5	3.4
SLG30/40-A	84	26	50	19	25	5.2	9.9	74	12	4.6
SLG30/40-B	84	26	49.3	28.5	26.4	5.2	9.9	74	12	4.6
SLG50-A	110	30	50	19	25	5.2	9.9	100	15	5.5
SLG50-B	110	29	49.3	28.5	26.4	5.2	9.9	100	15	5.5

SLG

SNC

SNT

SLP

SLB

SLW

SLF

# SNC Series

## Needle Gripper



COMPOSITE MATERIAL



FABRIC



### Features

- ◇ Handling the workpieces by needles
- ◇ Needles controlled by spring or double-acting pneumatic cylinder
- ◇ Designed with intersecting needles
- ◇ Adjustable needle stroke
- ◇ Reduce the effective contact area

### Advantages

- ◇ Suitable for handling small size workpieces
- ◇ Simple pneumatic valve, easy to control
- ◇ Short work cycle, speed up the process
- ◇ For handling narrow and long or irregular workpieces
- ◇ The workpiece can be prevented from falling even in the case of power failure
- ◇ Preset separately according to the thickness, size and shape of workpieces
- ◇ Reliable handling of high porous workpieces



### Application

- ◇ Needles with different dimensions, fixed or adjustable needle stroke is optional, to handle non-rigid or high porous material, which is hardly gripped by vacuum, such as composite material, fluffy fabric, filter material, woven FRP, carbon fiber, insulation and foam material, etc.

### Notice

- ◇ Be careful when taking the needle gripper, there are needles at the bottom
- ◇ The exhaust function must be reserved when the solenoid valve controls the air circuit in order to prevent abnormal temperature during high frequency action

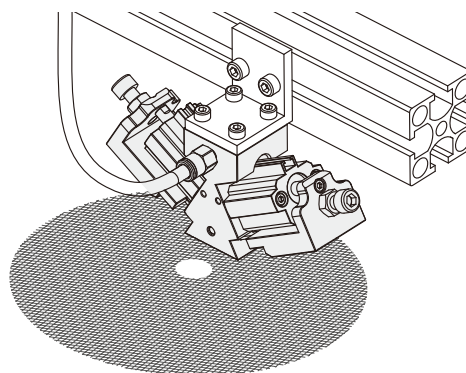

### Structure

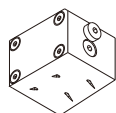

- ◇ Solid aluminum housing
- ◇ 4pcs needles, insertion angle 30°
- ◇ Needles are controlled by compressed air

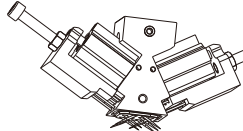

- ◇ Solid aluminum housing
- ◇ 10pcs needles, insertion angle 30°
- ◇ Double-acting pneumatic cylinder drive
- ◇ Continuous variable stroke adjustment

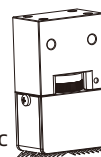

- ◇ Solid aluminum housing
- ◇ 32pcs needles, insertion angle 30°
- ◇ Compressed air drives plunger to control needle movement
- ◇ Continuous variable stroke adjustment

# SNC Series

## Needle Gripper

### How to order

## SNC 10

① ②

① Series	② Needle specification
SNC	4 - 4×φ0.8mm
	10 - 10×φ1.2mm
	32 - 32×φ0.8mm

### Technical parameters

Model	QTY of Needle PCS	Needle dia. mm	Air supply pressure range bar	Rated air supply pressure bar	Stroke mm	Working temperature °C	Weight g
SNC4	4	φ0.8	4.0~6.0	4.0	3	5~60	85
SNC10	10	φ1.2	3.0~7.0	4.0	7	5~60	310
SNC32	32	φ0.8	4.0~6.0	4.0	5	5~60	125

### Air circuit schematic diagram

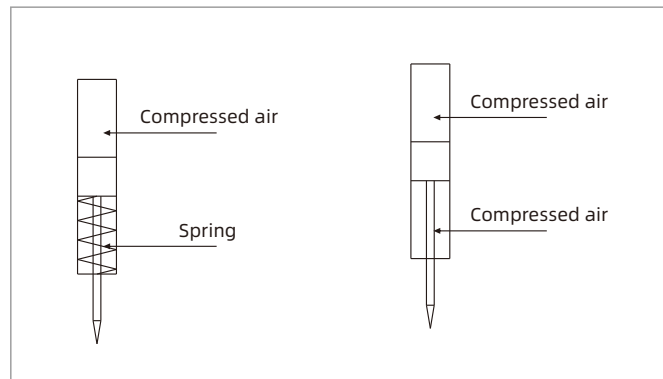

SNC4

SNC10 SNC32

### Dimensions(mm)

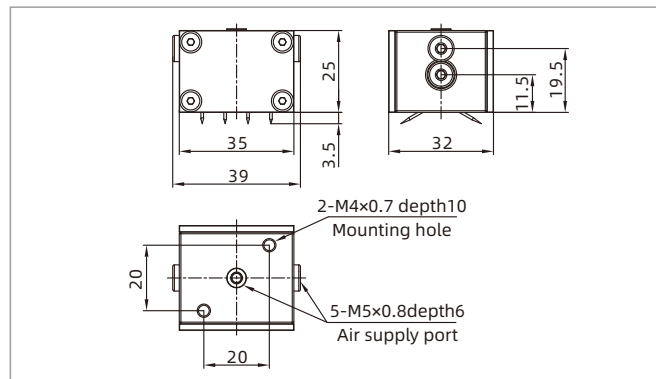

SNC4

### Dimensions(mm)

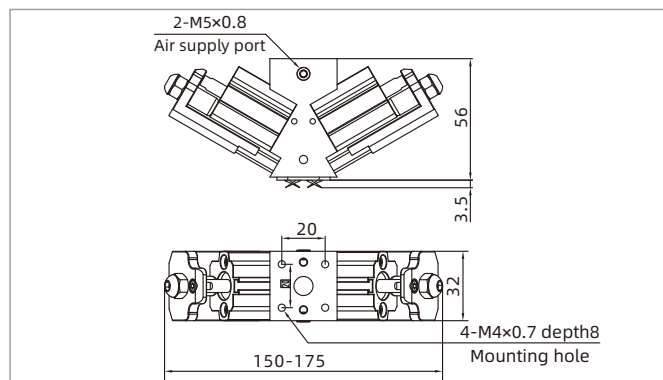

SNC10

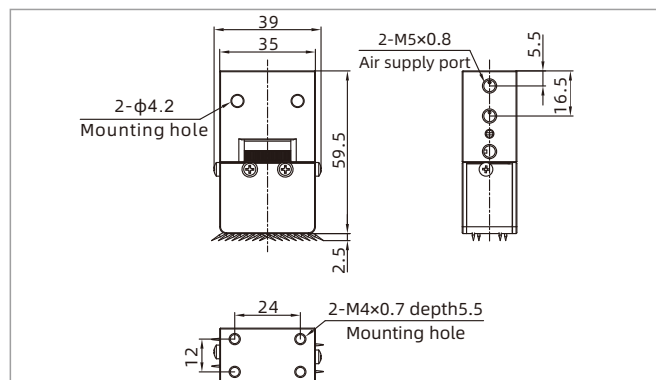

SNC32

# SNT Series

## Non-contact Suction Cup

**AIRBEST**



COMPOSITE MATERIAL



POROUS



### Features

- ◇ The suction cup "floats" on the air cushion during the gripping
- ◇ Low vacuum level, large vacuum flow
- ◇ Vacuum created based on Bernoulli principle
- ◇ No air go through the workpiece

### Advantages

- ◇ To achieve non-contact handling of workpiece
- ◇ Good compensation of air leakage
- ◇ Safely separates thin and porous workpiece
- ◇ Connect to compressed air directly, no need extra vacuum generator



### Application

- ◇ Fragile workpieces, such as silicon wafer, solar cell
- ◇ Porous workpieces, such as printed PCB, PVC board, textile
- ◇ Thin and light workpieces, such as plastic film, paper

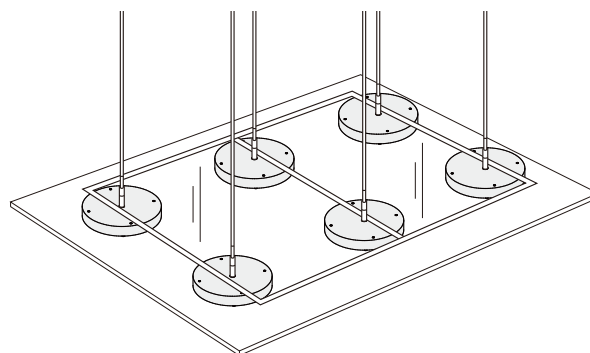

### Structure

- ◇ There are 4 threaded holes on the top
- ◇ Air supply ports on both vertical and horizontal side

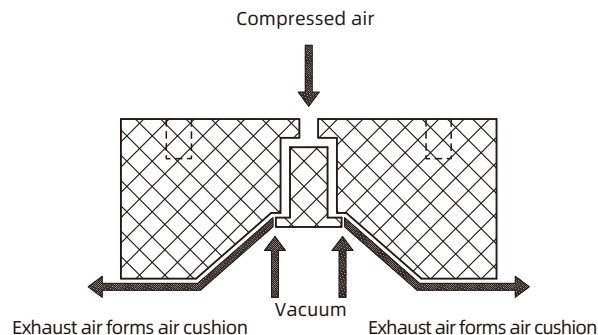

# SNT Series

## Non-contact Suction Cup

### How to order

SNT 30 - S N  
 ① ② ③ ④

① Series	② Diameter	③ Flow type	④ Cushion material
SNT	20 - $\phi$ 20mm	60 - $\phi$ 60mm	N - NBR (not available in SNT20)
	30 - $\phi$ 30mm	100 - $\phi$ 100mm	PK - PEEK (Mark free)
	40 - $\phi$ 40mm	120 - $\phi$ 120mm	PM - POM (Food grade) (Only available in SNT20)

### Selection

Model/Diameter 20	30	40	60	100	120
-	SNT30-SN	SNT40-SN	SNT60-SN	SNT100-SN	SNT120-SN
SNT20-SPK	SNT30-SPK	SNT40-SPK	SNT60-SPK	SNT100-SPK	SNT120-SPK
SNT20-SPM	-	-	-	-	-

### Technical parameters

Model	Pull-out force N	Air supply pressure bar	Max. air consumption NL/min	Working temperature °C	Weight g	Recommended hose dia. mm
SNT20	2	5.0	80	0~60	9.5	6
SNT30	4	5.0	100	0~60	32	8
SNT40	6.5	5.0	130	0~60	51	8
SNT60	17	5.0	225	0~60	116	6
SNT100	55.5	5.0	420	0~60	252	8
SNT120	104	5.0	420	0~60	331	8

◇ Note: The tested workpiece is rigid and airtight, air supply pressure range is 1.0 - 6.0bar, vertical action. The specified pull-out force does not include the safety factor

### Dimensions(mm)

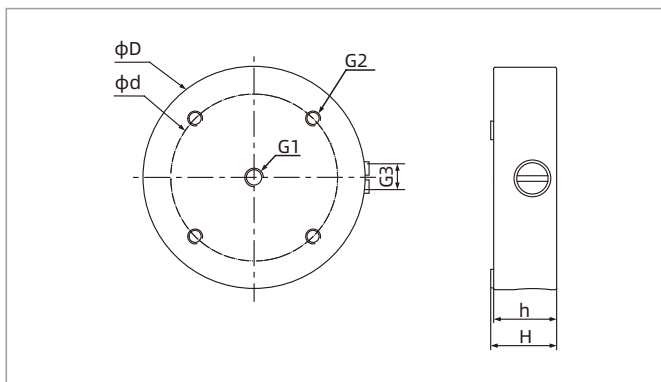

Model/Size	D	d	H	h	G1	G2	G3
SNT20	20	15	12.8	12	M5×0.8	4-M3×0.5depth5	-
SNT30	32	22	17.8	17	M5×0.8	4-M4×0.7depth6	M5×0.8
SNT40	40	32	17.8	17	G1/8	4-M4×0.7depth6	G1/8
SNT60	60	45	17.8	17	G1/8	4-M4×0.7depth6	G1/8
SNT100	100	75	17.8	17	G1/8	4-M4×0.7depth6	G1/8
SNT120	120	105	17.8	17	G1/8	4-M4×0.7depth6	G1/8

SNT

SLG

SNC

SNT

SLP

SLB

SLW

SLF

# SLP Series

## Flow Gripper

**AIRBEST**



NEW ENERGY



BATTERY



COMPOSITE MATERIAL



POROUS



### Features

- ◇ Large vacuum flow
- ◇ Integrated with vacuum generator, suction cup and silencer
- ◇ Vertical and horizontal mounting types
- ◇ Holes on the adsorbing surface, could avoid the deformation of workpiece

### Advantages

- ◇ Flat suction cup to prevent deformation of the workpiece
- ◇ Large vacuum flow, suitable for handling porous workpieces
- ◇ Easy to install, different choice for different application
- ◇ Simple structure, integrated design, connect to compressed air directly, no need extra vacuum generator



### Application

- ◇ Suitable for handling thin and fragile workpieces, such as mobile phone screen, aluminum foil
- ◇ Suitable for handling porous workpieces, such as printed PCB, PVC board
- ◇ Suitable for textile industry, such as fiber sheet

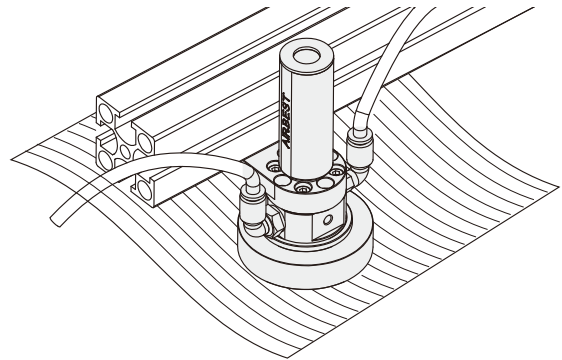

### Structure

- ◇ (1) Release/Vacuum detecting port
- ◇ (2) Vacuum generator
- ◇ (3) Silencer
- ◇ (4) Mounting flange
- ◇ (5) Air supply port
- ◇ (6) Adsorbing surface

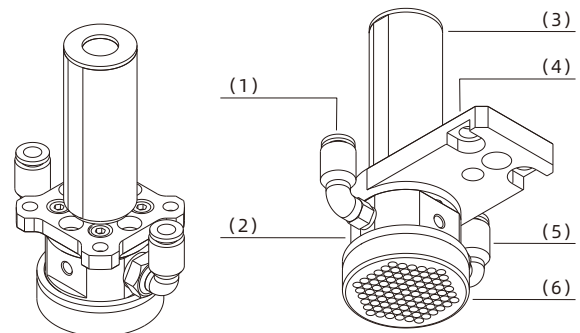

# SLP Series

## Flow Gripper

### How to order

**SLP 40 - M10 S D - F1**  
 ①      ②      ③      ④      ⑤      ⑥

① Series   ② Dia. of suction cup   ③ Specification of vacuum generator   ④ Exhaust direction   ⑤ Release function   ⑥ Mounting flange

<b>SLP</b>  40 - φ40 60 - φ60	M10 - Diameter φ10mm  M20 - Diameter φ20mm	S - Vertical + silencer   D - With release port	F1 - Vertical, 55×6mm F2 - Vertical, 84×9mm F3 - Horizontal, 71×9mm F4 - Horizontal, 95×9mm
--	--	---	--

### Selection

Model/ Diameter of suction cup	40	60
SLP40-M10SD-F1		SLP60-M10SD-F1
SLP40-M10SD-F3		SLP60-M10SD-F3
-		SLP60-M20SD-F2
-		SLP60-M20SD-F4

### Technical parameters

Model	Air supply pressure range bar	Rated air supply pressure bar	Max. vacuum level -kPa	Max. vacuum flow NL/min	Air consumption NL/min	Working temperature °C
SLP40-M10	1.0~7.0	5.0	11	320~450	145	0~60
SLP60-M10	1.0~7.0	5.0	11	330~550	145	0~60
SLP60-M20	1.0~7.0	5.0	4.5	970~1,195	260	0~60

### Vacuum flow(NL/min) at different vacuum levels (-kPa)

Model	Air supply pressure bar	Air consumption NL/min	Max. vacuum level -kPa									
			0	1.5	2.5	3.5	4.5	5.5	6.5	7.5	11	
SLP40-M10	5.0	145	450	430	410	420	350	300	250	170	100	11
SLP60-M10	5.0	145	550	530	470	420	350	300	250	170	100	11
SLP60-M20	5.0	260	1,195	1,120	1,050	980	880	-	-	-	-	4.5

### Air circuit schematic diagram

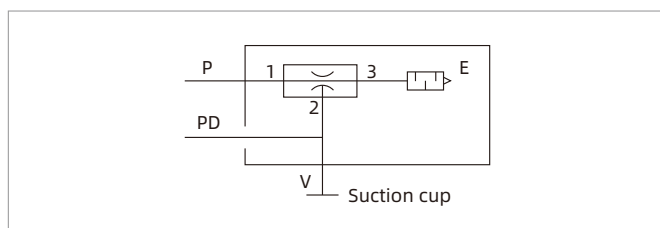

SLP

SLG

SNC

SNT

SLP

SLB

SLW

SLF

# SLP Series

## Flow Gripper



### Dimensions(mm)

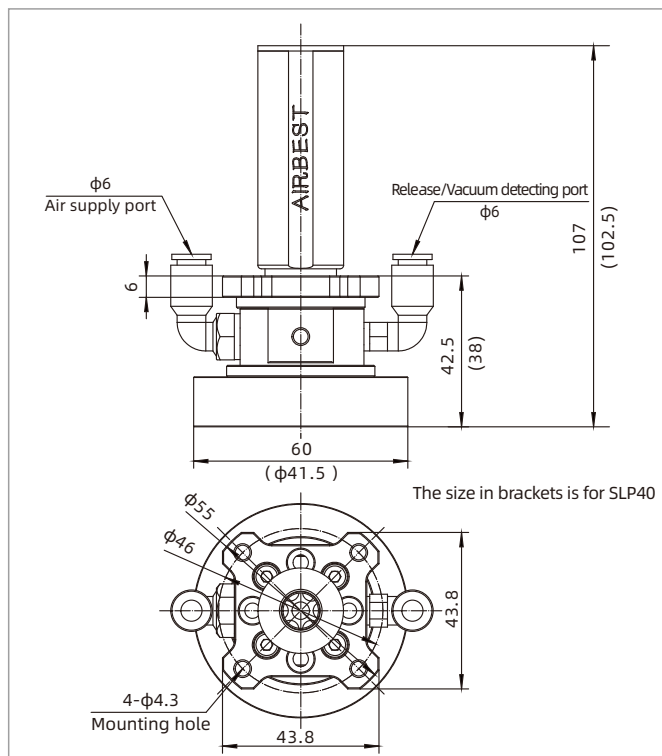

SLP60(40)-M10SD-F1

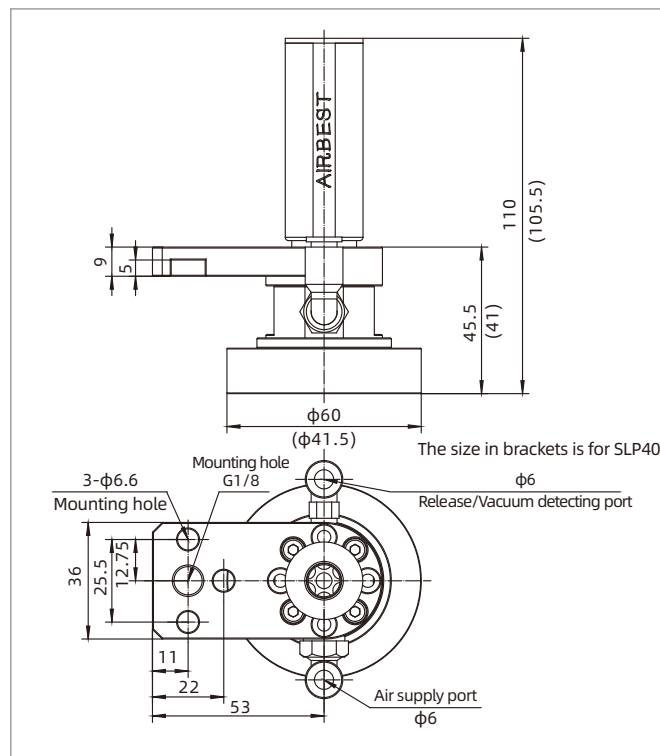

SLP60(40)-M10SD-F3

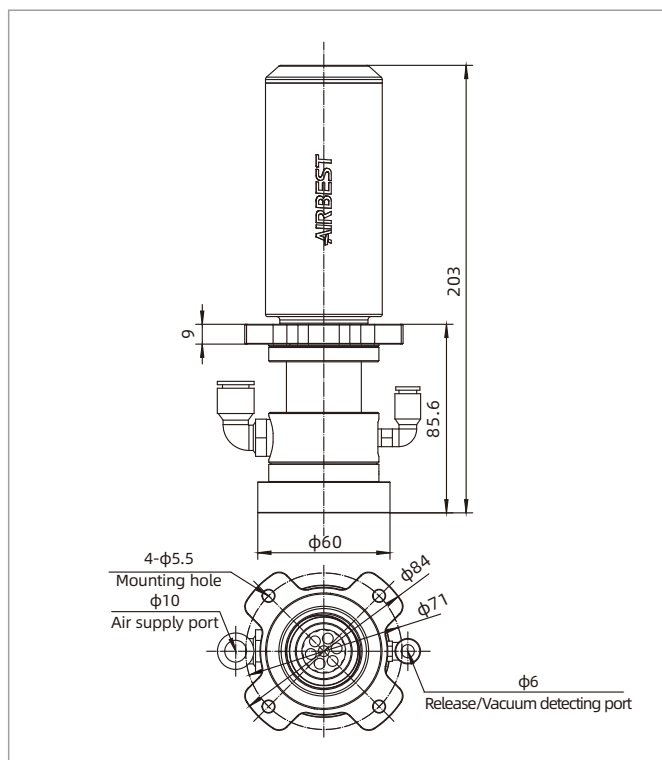

SLP60-M20SD-F2

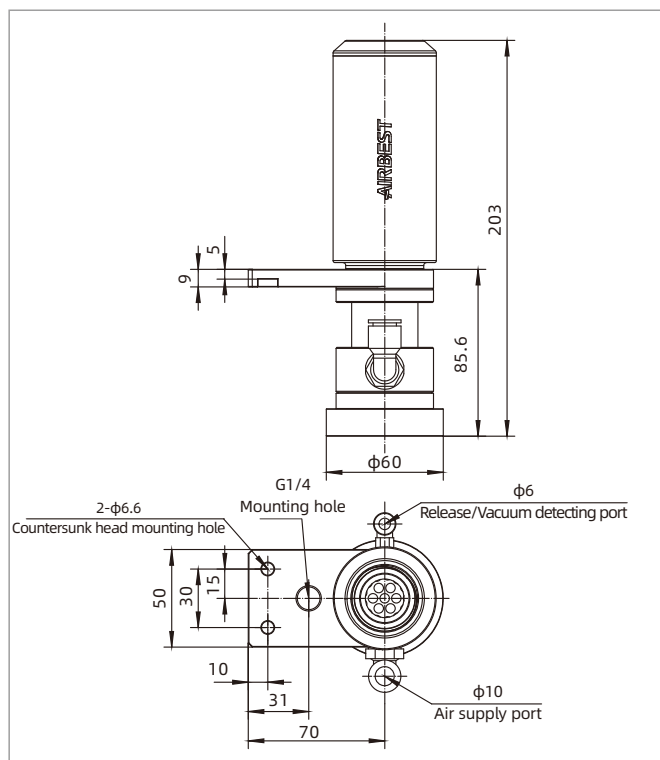

SLP60-M20SD-F4

# SLB Series

## Thin Lip Flow Gripper



ELECTRONICS    NEW ENERGY    POROUS



### Features

- ◇ Large vacuum flow
- ◇ Integrated with vacuum generator, suction cup, silencer/pagoda fitting
- ◇ Vertical and horizontal mounting types
- ◇ Suction cup with rubber material, flexible, high suction force, protect the surface of workpiece

### Advantages

- ◇ Flexible gripping, prevent damage to the workpiece during handling
- ◇ Large vacuum flow, suitable for handling porous workpiece
- ◇ Easy to install, different types for option
- ◇ Simple structure, integrated design, could connect to compressed air directly, no need extra vacuum generator
- ◇ Minimize noise, pagoda fitting could be used to collect the exhausted air, no pollution



### Application

- ◇ Suitable for handling porous workpieces, such as printed PCB, PVC board
- ◇ Suitable for food industry, such as biscuit, bread, etc.
- ◇ Suitable for handling irregular workpieces

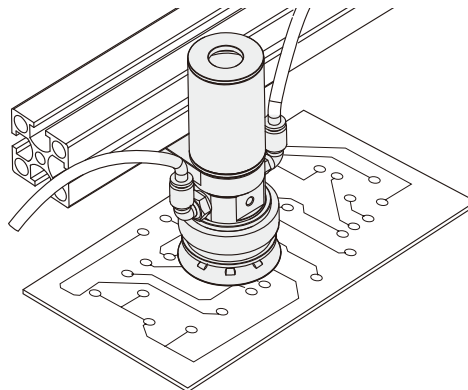

### Structure

- ◇ (1) Release/Vacuum detecting port
- ◇ (2) Mounting flange
- ◇ (3) Silencer
- ◇ (4) Air supply port
- ◇ (5) Vacuum generator
- ◇ (6) Adsorbing surface

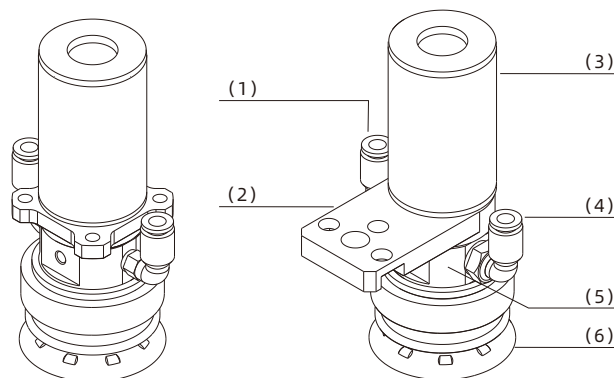

Special Vacuum Grippers

SLG

SNC

SNT

SLP

**SLB**

SLW

SLF

# SLB Series

## Thin Lip Flow Gripper

### How to order

**SLB 50 E - M10 S D - F13**  
 ①    ②    ③    ④    ⑤ ⑥    ⑦

① Series	② Dia. of suction cup	③ Material of suction cup	④ Specification of vacuum generator
SLB	30 - $\phi$ 30mm	WS - White silicone	M10 - Diameter $\phi$ 10mm
	50 - $\phi$ 50mm	E - EPDM	M20 - Diameter $\phi$ 20mm
	⑤ Exhaust direction	⑥ Vacuum release function	⑦ Mounting flange
	S - Vertical + silencer T - Vertical + pagoda fitting	D - With vacuum release port	F2 - Vertical, 84x9mm F4 - Horizontal, 95x9mm F11 - Horizontal, 71x9mm F13 - Vertical, 55x6mm

◇ Note: For specification of M20, white silicone material is not available

### Selection

Model/ Diameter of suction cup	30	50
SLB30E-M10SD-F11		SLB50E-M10SD-F11
SLB30E-M10SD-F13		SLB50E-M10SD-F13
SLB30E-M10TD-F11		SLB50E-M10TD-F11
SLB30E-M10TD-F13		SLB50E-M10TD-F13
-		SLB50E-M20SD-F2
-		SLB50E-M20SD-F4

### Technical parameters

Model	Air supply pressure range bar	Rated air supply pressure bar	Max. vacuum level -kPa	Max. vacuum flow NL/min	Air consumption NL/min	Working temperature °C
SLB30-M10	1.0~7.0	5.0	16	680~690	165	0~60
SLB50-M10	1.0~7.0	5.0	16	680~690	165	0~60
SLB50-M20	1.0~7.0	5.0	4.5	1,070~1,315	260	0~60

### Vacuum flow (NL/min) at different vacuum levels (-kPa)

Model	Air supply pressure bar	Air consumption NL/min	0	1.5	2.5	3.5	4.5	5.5	6.5	7.5	11	Max. vacuum level -kPa
SLB30-M10	5.0	165	550	530	470	420	350	300	250	170	100	16
SLB50-M10	5.0	165	550	530	470	420	350	300	250	170	100	16
SLB50-M20	5.0	260	1,315	1,120	1,050	980	880	-	-	-	-	4.5

# SLB Series

## Thin Lip Flow Gripper

### Dimensions(mm)

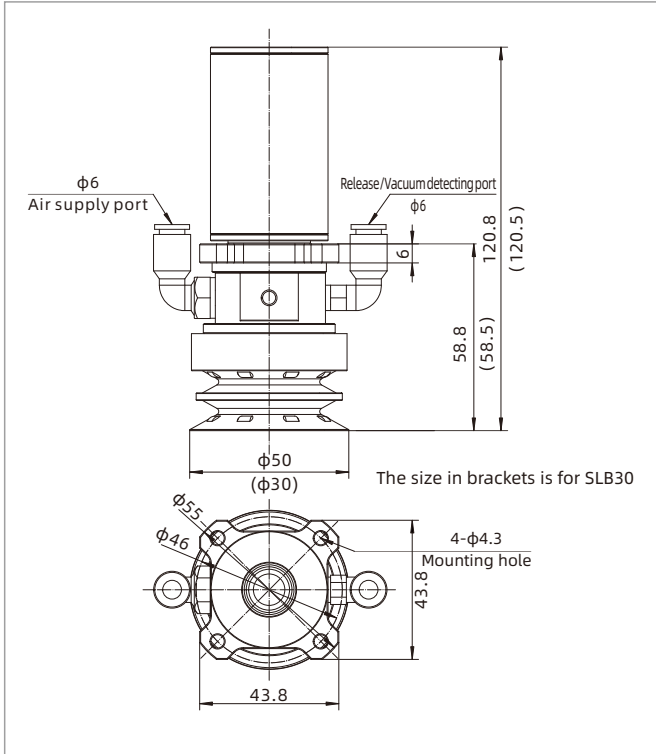

SLB50(30)E-M10SD-F13

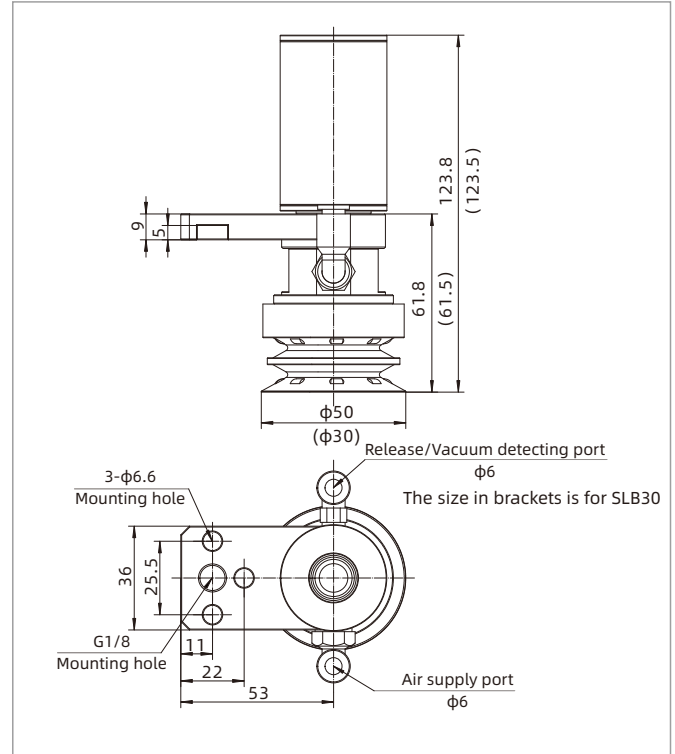

SLB50(30)E-M10SD-F11

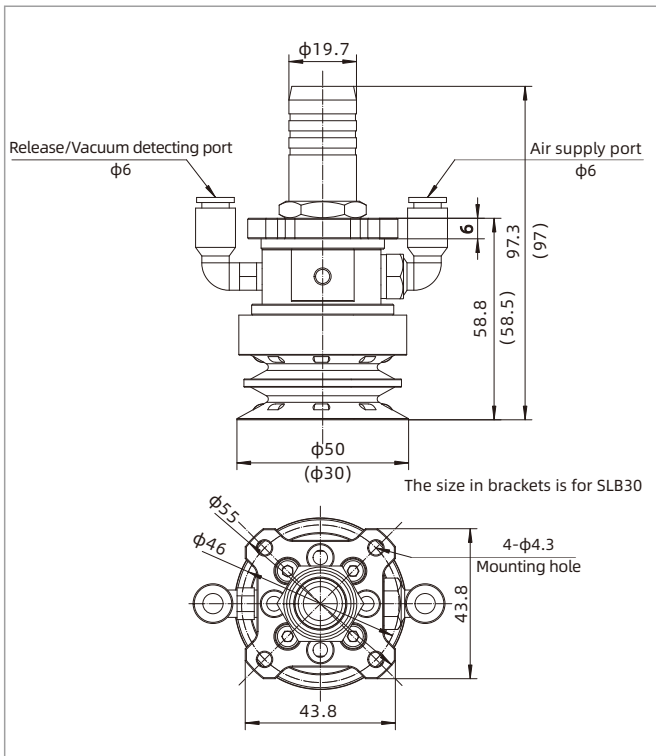

SLB50(30)E-M10TD-F13

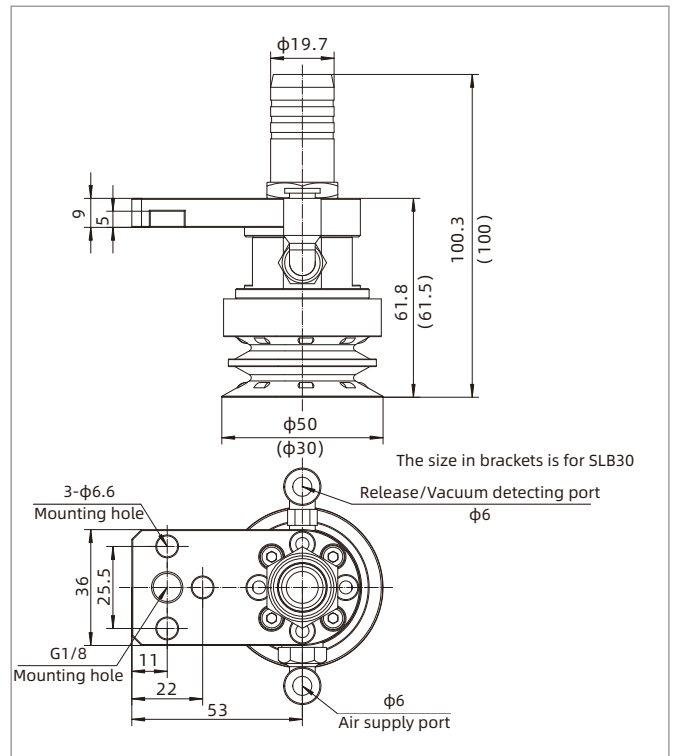

SLB50(30)E-M10TD-F11

# SLB Series

## Thin Lip Flow Gripper



### Dimensions(mm)

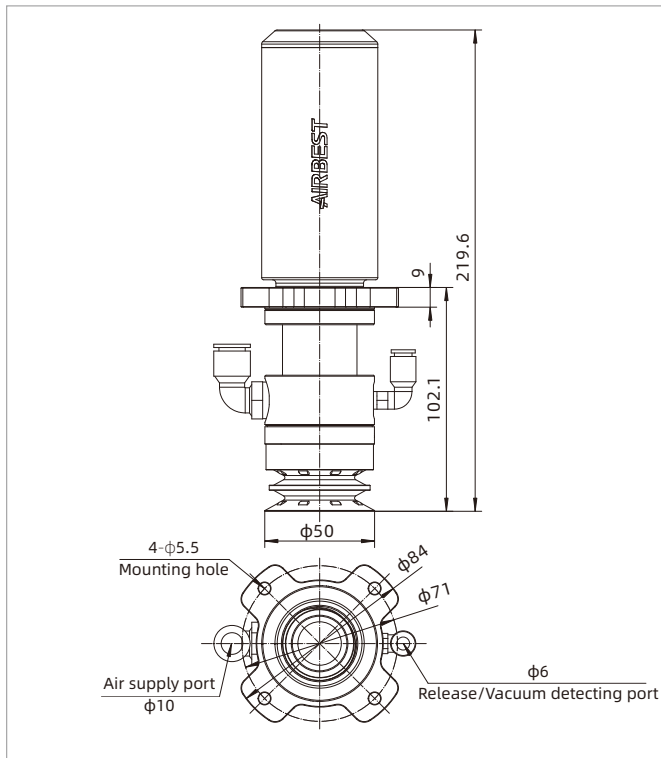

SLB50-M20SD-F2

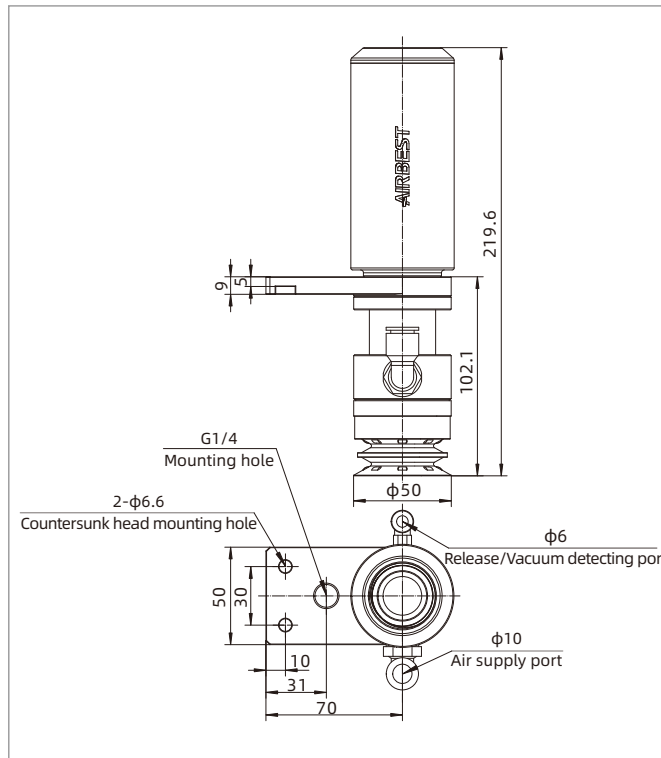

SLB50-M20SD-F4

# SLW Series

## Wafer Gripper



### Features

- ◇ Multihole adsorbing area, prevent the physical deformation of fragile workpiece
- ◇ Integrated with suction cup and vacuum generator
- ◇ Vertical exhaust and lateral exhaust for option
- ◇ Vertical and horizontal mounting types for option

### Advantages

- ◇ Reduce fragment rate
- ◇ With vacuum release port, improve efficiency
- ◇ Easy to install, different types for option
- ◇ Simple structure, integrated design, could connect to compressed air directly, no need extra vacuum generator



### Application

- ◇ Suitable for handling fragile workpieces, such as silicon wafer, solar cell, glass, etc.

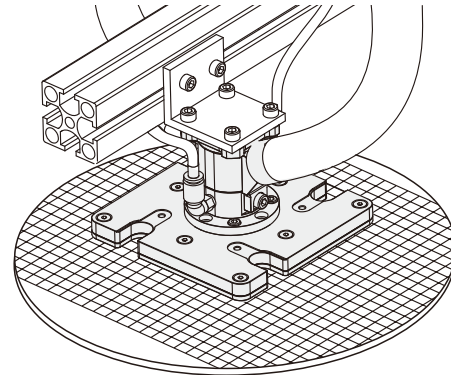

### Structure

- ◇ (1) Air supply port
- ◇ (2) Vacuum generator
- ◇ (3) Mounting flange
- ◇ (4) Release/Vacuum detecting port
- ◇ (5) Exhaust port
- ◇ (6) Adsorbing area

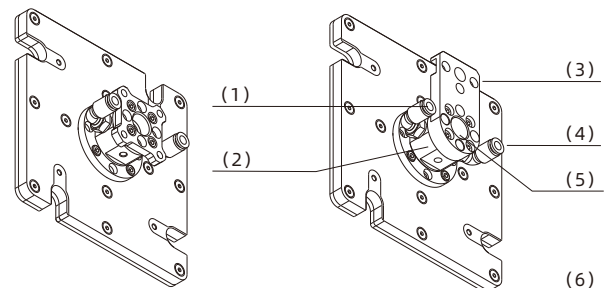

Special Vacuum Grippers

- SLG
- SNC
- SNT
- SLP
- SLB
- SLW**
- SLF

# SLW Series

## Wafer Gripper

### How to order

## SLW 115 PK - M10 I - F1

①      ②      ③      ④      ⑤      ⑥

① Series	② Dimension	③ Material of suction cup	④ Specification of vacuum generator	⑤ Exhaust direction	⑥ Mounting flange
SLW	100 - 100x55mm	PK - PEEK	M10 - Diameter $\phi$ 10mm	I - Vertical exhaust	F1 - Vertical, 55x6mm
	115 - 115x115mm	AE - Aluminum plate+	M15 - Diameter $\phi$ 15mm	Y - Lateral exhaust	F3 - Horizontal, 71x9mm
	146 - 146x146mm	EPDM support cushion			F9 - Vertical, Triangular flange
	170 - 170x105mm	FT - Sponge+PTFE			
	120 - $\phi$ 120mm				
	150 - $\phi$ 150mm				
	180 - $\phi$ 180mm				

### Selection

Model/ Specification of vacuum generator M10		M15	
SLW100PK-M10I-F1	SLW100PK-M10Y-F1	SLW120AE-M15I-F9	SLW120FT-M15I-F9
SLW100PK-M10I-F3	SLW100PK-M10Y-F3	-	-
SLW115PK-M10I-F1	SLW115PK-M10Y-F1	SLW150AE-M15I-F9	SLW150FT-M15I-F9
SLW115PK-M10I-F3	SLW115PK-M10Y-F3	-	-
SLW146PK-M10I-F1	SLW146PK-M10Y-F1	SLW180AE-M15I-F9	SLW180FT-M15I-F9
SLW146PK-M10I-F3	SLW146PK-M10Y-F3	-	-
SLW170PK-M10I-F1	SLW170PK-M10Y-F1	-	-
SLW170PK-M10I-F3	SLW170PK-M10Y-F3	-	-

### Technical parameters

Model	Air supply pressure range bar	Rated air supply pressure bar	Max. vacuum level -kPa	Max. vacuum flow NL/min	Air consumption NL/min	Working temperature °C
SLW115-M10	1.0~7.0	5.0	11	400~430	150	0~60
SLW146-M10	1.0~7.0	5.0	11	410~440	150	0~60
SLW100-M10	1.0~7.0	5.0	11	330~460	150	0~60
SLW170-M10	1.0~7.0	5.0	11	350~490	150	0~60
SLW120-M15	1.0~7.0	5.0	4.5	370~460	150	0~60
SLW150-M15	1.0~7.0	5.0	4.5	370~460	160	0~60
SLW180-M15	1.0~7.0	5.0	4.5	370~460	180	0~60

# SLW Series

## Wafer Gripper

### Vacuum flow (NL/min) at different vacuum levels (-kPa)

Model	Air supply pressure bar	Air consumption NL/min	0	1.5	2.5	3.5	4.5	5.5	6.5	7.5	11	Max. vacuum level -kPa
SLW115-M10	5.0	150	400	375	363	334	315	289	265	246	215	11
SLW146-M10	5.0	150	410	386	370	330	324	296	374	258	234	11
SLW100-M10	5.0	150	330	311	285	263	241	219	198	179	160	11
SLW170-M10	5.0	150	350	330	310	280	263	238	219	200	180	11
SLW120-M15	5.0	150	440	429	407	385	363	335	308	275	-	4.5
SLW150-M15	5.0	160	440	429	407	385	363	335	308	275	-	4.5
SLW180-M15	5.0	180	440	429	407	385	363	335	308	275	-	4.5

### Dimensions(mm)

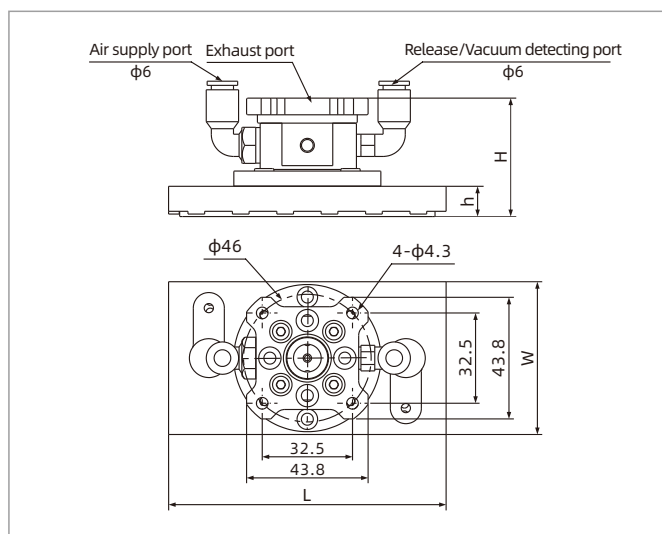

SLW□PK-M10I-F1

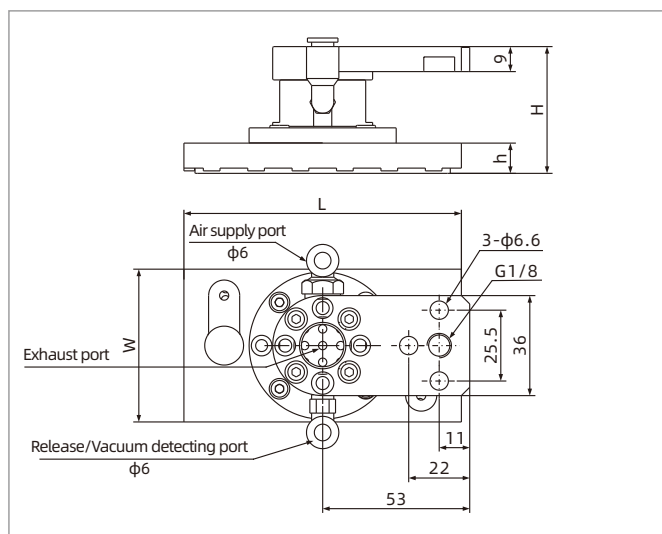

SLW□PK-M10I-F3

Model/Size	L	W	H	h	Weight g
SLW100PK-M10I-F1	100	55	43	11	220
SLW115PK-M10I-F1	115	115	43	11	350
SLW146PK-M10I-F1	146	146	43	11	458
SLW170PK-M10I-F1	170	105	43	11	354

Model/Size	L	W	H	h	Weight g
SLW100PK-M10I-F3	100	55	46	11	135
SLW115PK-M10I-F3	115	115	46	11	376
SLW146PK-M10I-F3	146	146	46	11	484
SLW170PK-M10I-F3	170	105	46	11	386

# SLW Series

## Wafer Gripper

### Dimensions(mm)

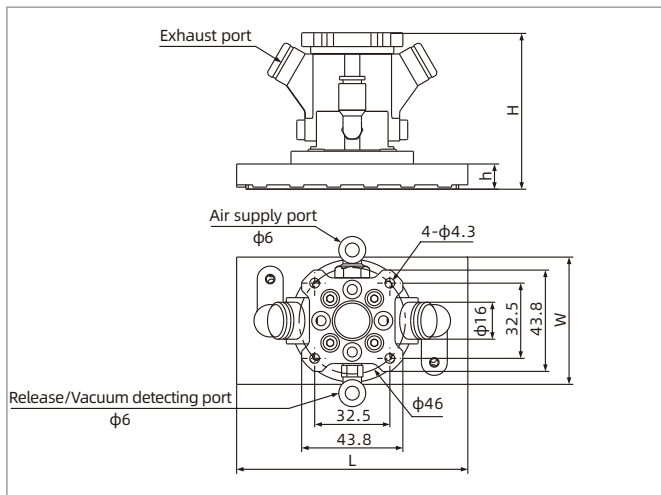

SLW□PK-M10Y-F1

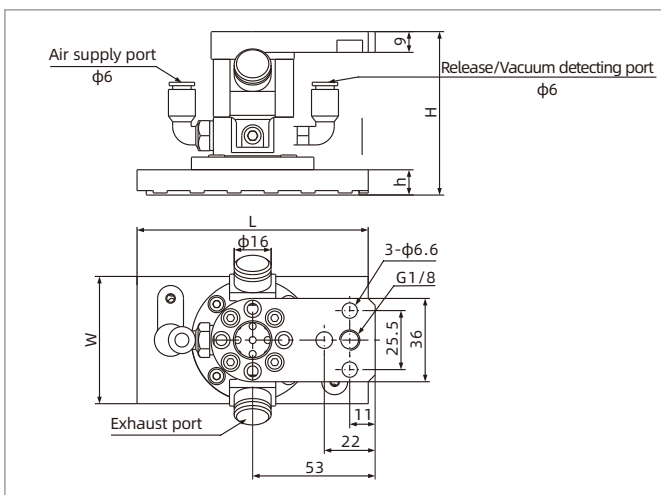

SLW□PK-M10Y-F3

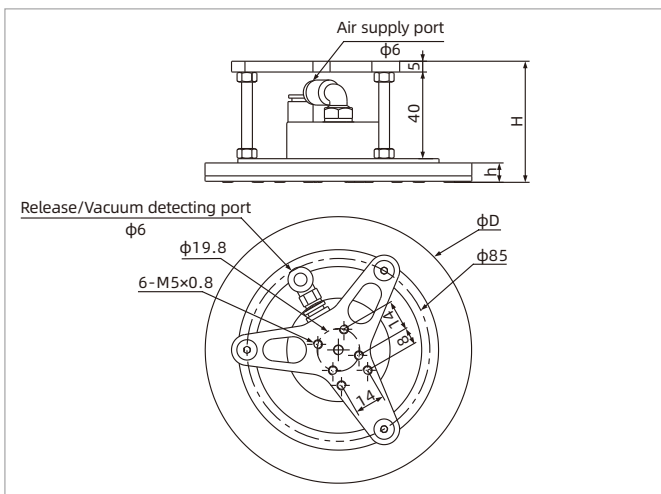

SLW□AE-M15I-F9

Model/Size	L	W	H	h	Weight g
SLW100PK-M10Y-F1	100	55	68	11	284
SLW115PK-M10Y-F1	115	115	68	11	415
SLW146PK-M10Y-F1	146	146	68	11	523
SLW170PK-M10Y-F1	170	105	68	11	420

Model/Size	L	W	H	h	Weight g
SLW100PK-M10Y-F3	100	55	71	11	310
SLW115PK-M10Y-F3	115	115	71	11	441
SLW146PK-M10Y-F3	146	146	71	11	549
SLW170PK-M10Y-F3	170	105	71	11	445

Model/Size	D	H	h	Weight g
SLW120AE-M15I-F9	124	53.5~57	9.5	343
SLW120FT-M15I-F9	124	56~59	12	375
SLW150AE-M15I-F9	149	53.5~57	9.5	418
SLW150FT-M15I-F9	149	56~59	12	472
SLW180AE-M15I-F9	179	53.5~57	9.5	632
SLW180FT-M15I-F9	179	56~59	12	630

## **E** Vacuum Grippers

# Vacuum grippers

## Products overview

### Vacuum grippers

#### 379 TXN Series

##### Vacuum Gripper-Mini Type

- ◇ Vacuum type: Built-in vacuum generator  
Without vacuum generator
- ◇ Adsorption surface type: Sponge  
Suction cup



ELECTRONICS PACKAGING



RoHS

#### 397 TXP Series

##### Vacuum Gripper-Oval Shaped

- ◇ Vacuum type: External Blower
- ◇ Adsorption surface type: Sponge



PACKAGING



#### 385 TXD Series

##### Vacuum Gripper-Light Load Type

- ◇ Vacuum type: Built-in vacuum generator
- ◇ Adsorption surface type: Sponge  
Suction cup



PACKAGING



RoHS

#### 399 TXH Series

##### Vacuum Gripper-Heavy Load Type

- ◇ Vacuum type: With vacuum generator  
Without vacuum generator
- ◇ Adsorption surface type: Sponge  
Suction cup



UNIVERSAL HEAVY LOAD

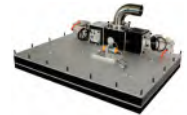

RoHS

#### 388 TXC Series

##### Vacuum Gripper -Vacuum Generator Standard Type

- ◇ Vacuum type: Built-in vacuum generator
- ◇ Adsorption surface type: Sponge  
Suction cup



UNIVERSAL



RoHS

#### 403 TXL Series

##### Vacuum Gripper -Combined Type

- ◇ Vacuum type: Built-in vacuum generator  
External Blower
- ◇ Adsorption surface type: Sponge  
Suction cup



UNIVERSAL



RoHS

#### 393 TXM Series

##### Vacuum gripper-blower standard type

- ◇ Vacuum type: External Blower
- ◇ Adsorption surface type: Sponge  
Suction cup



UNIVERSAL



RoHS

# TXN Series

## Vacuum Gripper-Mini Type



ELECTRONICS



PACKAGING

### Features

- ◇ Small size, simple structure and light weight
- ◇ Various vacuum sources, can select built-in vacuum generator or external blower
- ◇ Sponge type: Conventional sponge, Mark free sponge, Conductive sponge can be selected
- ◇ Suction cup type: The size, material and rows of suction cups are optional

### Advantages

- ◇ It is easy to install and maintain
- ◇ Customers can choose accurately according to the actual application, built-in vacuum generator structure can save space and create vacuum fastly, easy to control
- ◇ Sponge type can achieve flexible contact, when touching with glass and other fragile workpieces, it could be mark free and non-positioning suction
- ◇ Suction cup type has throttling effect, which can be used to adsorb hollow porous, uneven, different shapes of workpieces

### Applications

- ◇ Used for handling light and small fragile workpieces, such as electronics, glass screen, electronic components and PCB board, etc.
- ◇ Sponge type can also be used for sorting and labeling in packaging industry

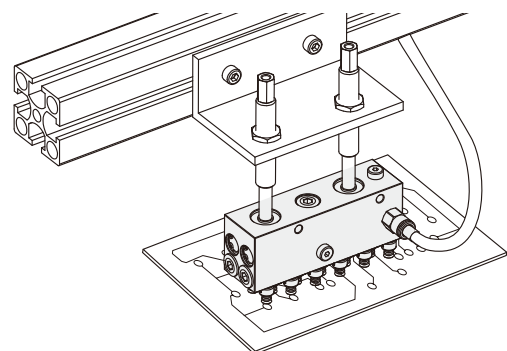

Vacuum gripper

TXN

TXD

TXC

TXM

TXP

TXH

TXL

### Structure

- ◇ The main body is made of aluminum alloy
- ◇ The vacuum gripper TXN22 × 38/TXN22 × 76 are without vacuum generator, others are with built-in vacuum generator

### How to order

## TXN 15×76 - B5N WS - C

①                      ②                      ③                      ④                      ⑤

① Series	② Dimension	③ Adsorption surface type	④ Material of suction cup	⑤ Vacuum type
TXN	22×38	A - Conventional sponge	Nil - Default,NBR	Nil - Without vacuum generator
	22×76	AT - Mark free sponge	WS - White silicone	C - With built-in vacuum generator
	15×76	CA - Conductive sponge		
	15×90	B3 - $\phi 3$ Single-row suction cup		
	27×90	B5 - $\phi 5$ Single-row suction cup		
	60×120	B7 - $\phi 7$ Single-row suction cup		
		B3N - $\phi 3$ double-row suction cup		
		B5N - $\phi 5$ double-row suction cup		
		B7N - $\phi 7$ double-row suction cup		
		B3D - $\phi 3$ four-row suction cup		
		B5D - $\phi 5$ four-row suction cup		
		B7D - $\phi 7$ four-row suction cup		

### Selection - Sponge type

Model/Adsorption surface type	A - Conventional sponge	AT - Mark free sponge	CA - Conductive sponge
TXN22×38-□	TXN22×38-A	TXN22×38-AT	TXN22×38-CA
TXN22×76-□	TXN22×76-A	TXN22×76-AT	TXN22×76-CA
TXN60×120-□-C	TXN60×120-A-C	-	-

### Selection - Suction cup type

Model/Suction cup material	Nil - NBR	WS - White silicone
TXN15×76-B5N□-C	TXN15×76-B5N-C	TXN15×76-B5NWS-C
TXN15×76-B7N□-C	TXN15×76-B7N-C	TXN15×76-B7NWS-C
TXN15×90-B3□-C	TXN15×90-B3-C	TXN15×90-B3WS-C
TXN15×90-B5□-C	TXN15×90-B5-C	TXN15×90-B5WS-C
TXN15×90-B7□-C	TXN15×90-B7-C	TXN15×90-B7WS-C
TXN15×90-B3N□-C	TXN15×90-B3N-C	TXN15×90-B3NWS-C
TXN15×90-B5N□-C	TXN15×90-B5N-C	TXN15×90-B5NWS-C
TXN15×90-B7N□-C	TXN15×90-B7N-C	TXN15×90-B7NWS-C
TXN27×90-B3D□-C	TXN27×90-B3D-C	TXN27×90-B3DWS-C
TXN27×90-B5D□-C	TXN27×90-B5D-C	TXN27×90-B5DWS-C
TXN27×90-B7D□-C	TXN27×90-B7D-C	TXN27×90-B7DWS-C

# TXN22×38/TXN22×76

## Vacuum Gripper-Mini Type

### Features

- ◇ The gripper is used in the handling and sorting process of light and small workpieces. It is suitable to handle multihole workpieces and partial leakage workpieces



### Technical parameters

Model	Theoretical suction force N	Recommended min. flow of vacuum generator NL/min	Optional function	Working temperature °C	Weight g	Recommended hose dia.(mm) Vacuum port (V)
TXN22×38	18	≥40	Mark free/Conductive	0-60	45	φ8
TXN22×76	34	≥60	Mark free/Conductive	0-60	68	φ8

- ◇ Note: 1. Testing vacuum level is -60kPa, the data of theoretical suction force as above are figured out in the condition that the vacuum gripper is fully covered by a rigid airtight workpiece, and without considering safety factor.
- 2. The mark free in the optional function of the above table indicates that special materials are attached to the sponge surface to reduce the mark on the contact surface.
- 3. Conductivity in the optional function shown in the above table indicates the use of special conductive sponge materials.

### Dimensions(mm)

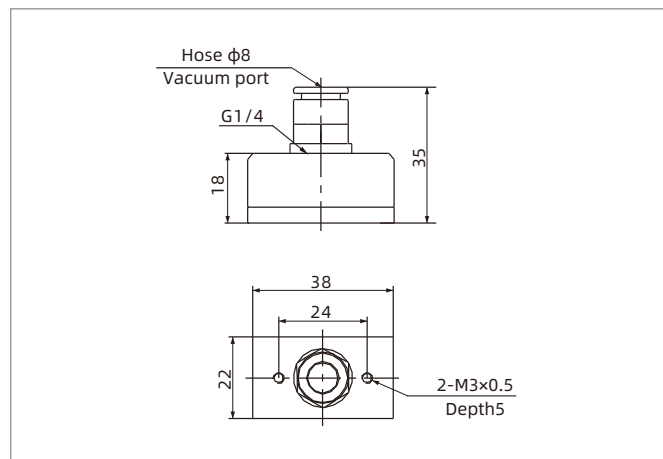

TXN22x38

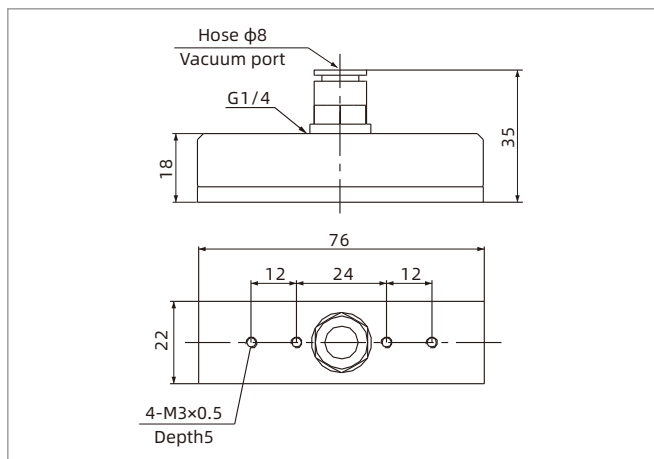

TXN22x76

### Spare parts selection

Item	Sponge model	Dimension mm	Application
22×38 Conventional sponge	TXN38-A	22×38×4	Conventional application
22×38 Mark free sponge	TXN38-AT	22×38×4	Mark free application
22×38 Conductive sponge	TXN38-CA	22×38×4	Conductive application
22×76 Conventional sponge	TXN76-A	22×76×4	Conventional application
22×76 Mark free sponge	TXN76-AT	22×76×4	Mark free application
22×76 Conductive sponge	TXN76-CA	22×76×4	Conductive application

# TXN15×76

## Vacuum Gripper-Mini Type

### Features

- ◇ The gripper is used in the handling and sorting process of light and small workpieces. It is suitable to handle multihole workpieces and partial leakage workpieces



### Technical parameters

Model	Air supply pressure bar	Max.vacuum level -kPa	Max.vacuum flow NL/min	Air consumption NL/min	Working temperature °C	QTY of suction cup pcs	Weight g
TXN15×76	5.0	85	40	45	0~60	10	110

### Dimensions (mm)

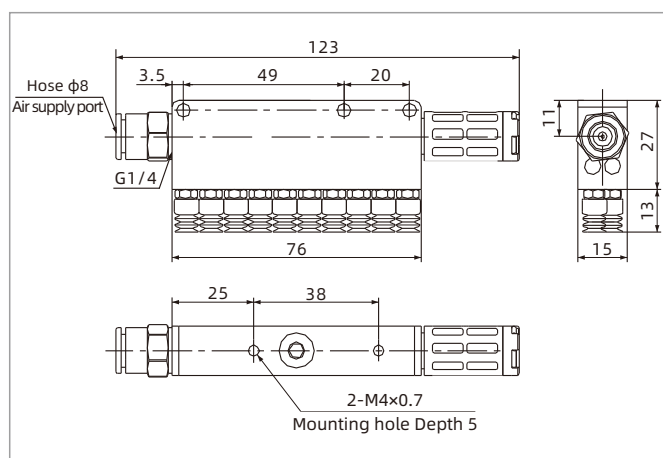

TXN15×76

### Spare parts selection

Item	Model of suction cup	Diameter of suction cup mm
TXN suction cup	SPC5N    SPC5WS	φ5
TXN suction cup	SPC7N    SPC7WS	φ7

# TXN15×90/TXN27×90



## Vacuum Gripper-Mini Type

### Features

- ◇ The gripper has throttling effect, which can be used to adsorb hollow porous, uneven, different shapes of workpieces. It can achieve suction without positioning, and can effectively grasp in case of leakage to protect workpieces



### Technical parameters

Model	Air supply pressure range bar	Max.vacuum level covered area 100%	Max.vacuum level covered area 25%	Max.vacuum flow NL/min	Air consumption NL/min	Working temperature °C	QTY of suction cup pcs	Weight g
TXN15×90	5.0-6.0	88	50	140	77	0~80	9/11	150
TXN27×90	5.0-6.0	88	25	140	77	0~80	22	190

- ◇ Note: 1. TXN15 × 90 can be made into single-row and double-row suction cups. The suction cup quantity of single-row is 9pcs, the suction cup quantity of double-row is 11pcs.
- 2. TXN27 × 90 can be only made into four-row suction cups, and the quantity of suction cups is 22pcs.

### Dimensions(mm)

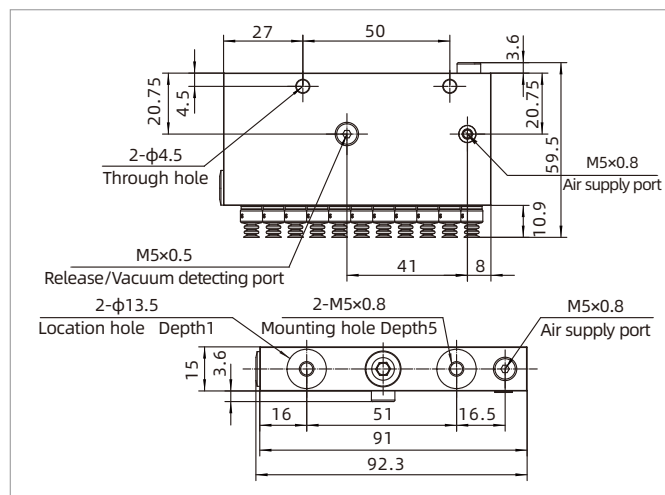

TXN15×90

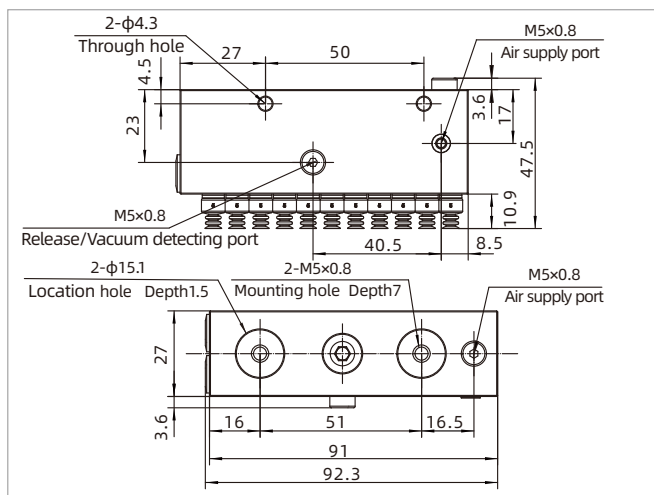

TXN27×90

Vacuum gripper

- TXN
- TXD
- TXC
- TXM
- TXP
- TXH
- TXL

# TXN60×120



## Vacuum Gripper-Mini Type

### Features

- ◇ The gripper is used in the handling and sorting process of light and small workpieces. It is suitable to handle multihole workpieces and partial leakage workpieces



### Technical parameters

Model	Air supply pressure bar	Max.vacuum level -kPa	Max.vacuum flow NL/min	Air consumption NL/min	Working temperature °C	Air supply port	Noise level dB(A)	Weight g
TXN60×120-A	-	-	-	-	0-60	G1/8	/	230
TXN60×120-A-C	4.0	85	120	70	0-60	G1/8	65	300

### Dimensions(mm)

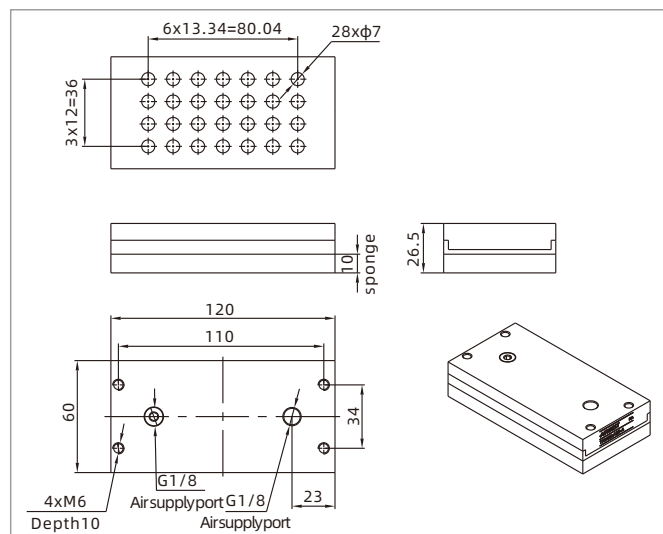

TXN60x120-A

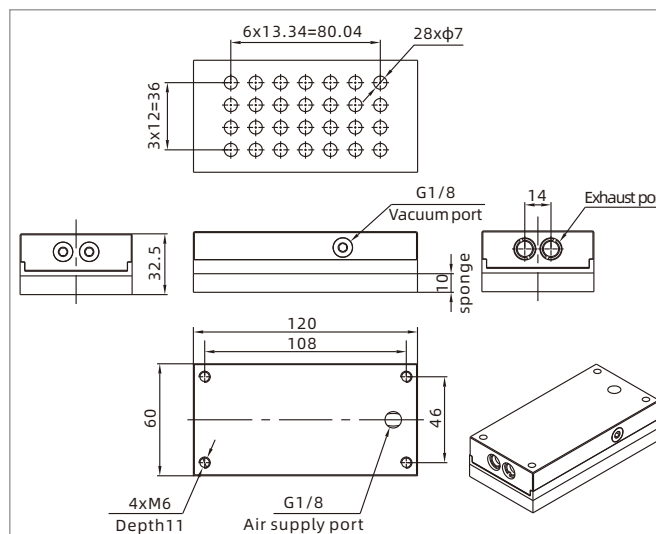

TXN60x120-A-C

### Spare parts selection

Item	Model	Dimension mm
60x120 sponge	TXN120-A	60x120x10

# TXD Series

## Vacuum Gripper-Light Load Type



PACKAGING



### Features

- ◇ The housing is made of high quality aluminum alloy
- ◇ With built-in large flow vacuum generator
- ◇ Suction cup adsorption surface type, with built-in throttling function
- ◇ Sponge adsorption surface type, with large area structure of inner cavity

### Advantages

- ◇ High strength and light weight
- ◇ Fast reaction time
- ◇ The inner cavity is large enough to handle the workpiece with obvious height difference on the surface



### Applications

- ◇ Suction cup type is used to handle light and small sensitive workpieces, such as electronics, glass screen and electronic components, etc.
- ◇ Suction cup type is with built-in throttling function, which can be used to handle workpieces with leakage
- ◇ Sponge type is used for sorting and packing in packaging industry

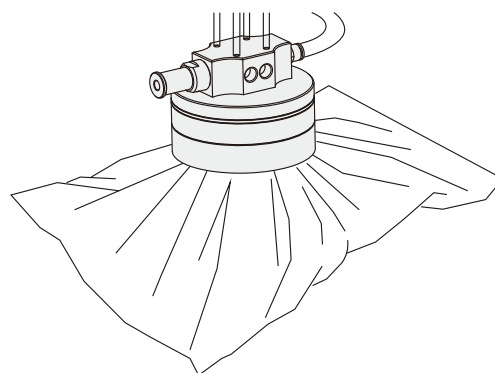

### Structure

- ◇ Vacuum source has flow type and vacuum type
- ◇ The adsorption surface has two structures: round and square
- ◇ Air supply port is equipped with  $\phi 8$  one-touch fitting, which can be directly connected to the hose. There is a vacuum port on the side. The exhaust way is direct exhaust.

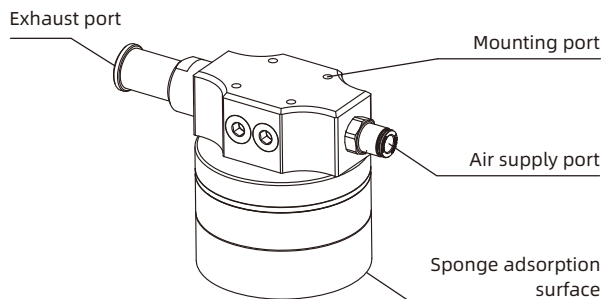

Vacuum gripper

TXN

**TXD**

TXC

TXM

TXP

TXH

TXL

# TXD Series

## Vacuum Gripper-Light Load Type

### How to order

TXD 80 S - H  
①   
②   
③   
④

① Series	② Dimension	③ Adsorption surface type		④ Vacuum source type
TXD	80	R	- Square sponge	H - Vacuum type (-95kPa)
	100	S	- Round sponge	L - Flow type (-75kPa)
	120	B3N/B5N/B7N	- Round NBR suction cup	
		B3WS/B5WS/B7WS	- Round silicone suction cup	

### Selection-Sponge type

Model/adsorption surface type	R - Square sponge		S - Round sponge	
TXD80□-□	TXD80R-H	TXD80R-L	TXD80S-H	TXD80S-L
TXD100□-□	TXD100R-H	TXD100R-L	TXD100S-H	TXD100S-L
TXD120□-□	TXD120R-H	TXD120R-L	TXD120S-H	TXD120S-L

### Selection-suction cup type

Model/suction cup material	Nil-NBR		WS-White silicone	
TXD80B3□-□	TXD80B3N-H	TXD80B3N-L	TXD80B3WS-H	TXD80B3WS-L
TXD80B5□-□	TXD80B5N-H	TXD80B5N-L	TXD80B5WS-H	TXD80B5WS-L
TXD80B7□-□	TXD80B7N-H	TXD80B7N-L	TXD80B7WS-H	TXD80B7WS-L

### Technical parameters

Model	Rated air supply pressure bar	Max.vacuum level -kPa	Max.vacuum flow NL/min	Air consumption NL/min	Weight kg	Recommended hose dia. (mm) Air supply port P
TXD80R-L	6.0	75	180	120	0.55	φ8
TXD80R-H	5.0	95	170	125	0.55	φ8
TXD80S-L	6.0	75	180	120	0.5	φ8
TXD80S-H	5.0	95	170	125	0.5	φ8
TXD80B-L	6.0	75	180	120	0.65	φ8
TXD80B-H	5.0	95	170	125	0.7	φ8
TXD100R-L	6.0	75	180	120	0.65	φ8
TXD100R-H	5.0	95	170	125	0.65	φ8
TXD100S-L	6.0	75	180	120	0.6	φ8
TXD100S-H	5.0	95	170	125	0.6	φ8
TXD120R-L	6.0	75	180	120	0.73	φ8
TXD120R-H	5.0	95	170	125	0.73	φ8
TXD120S-L	6.0	75	180	120	0.8	φ8
TXD120S-H	5.0	95	170	125	0.8	φ8

# TXD Series

## Vacuum Gripper-Light Load Type

### Dimensions(mm)

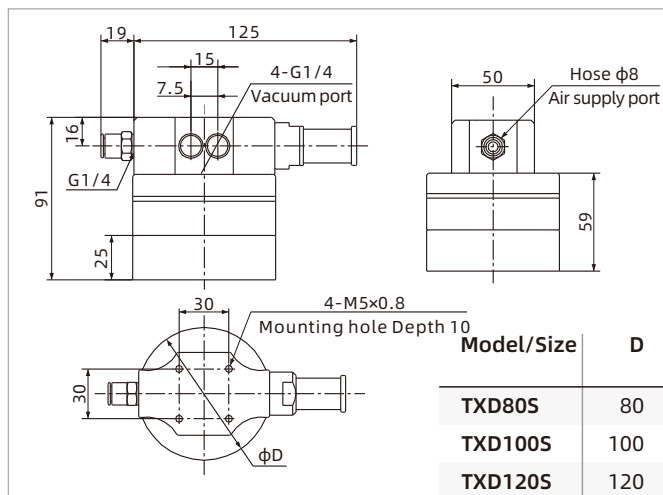

TXD□S - Round sponge

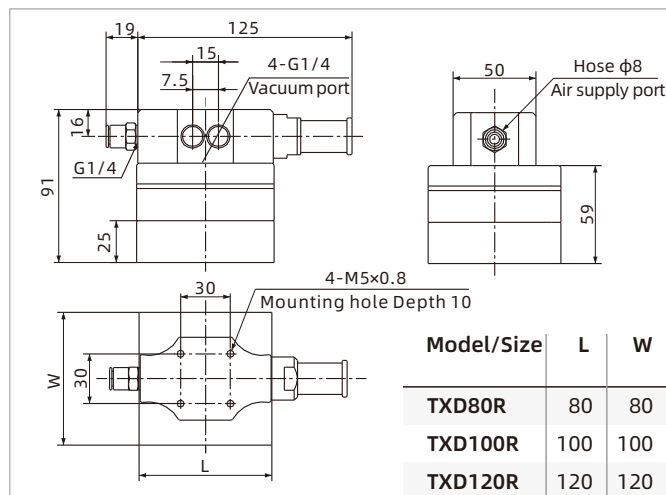

TXD□R - Square sponge

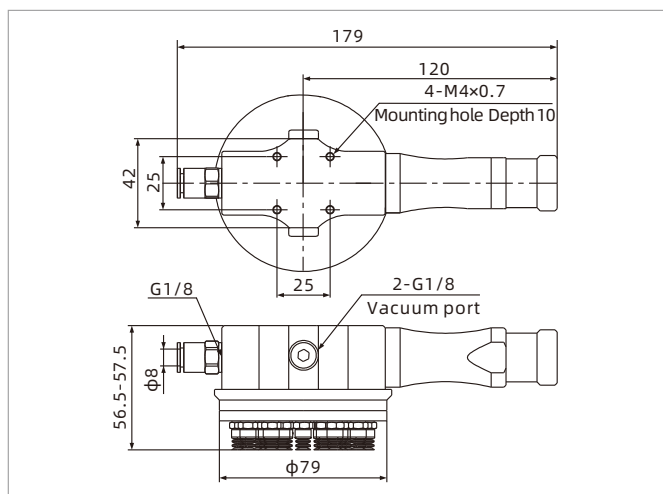

TXD80B - Round suction cup

### Spare parts selection

Item	Adsorption surface model	Adsorption surface dimension mm	Applicable gripper model
TXD80R Sponge	TXD80RA	80×80×25	TXD80R-H、TXD80R-L
TXD80S Sponge	TXD80SA	φ80×25	TXD80S-H、TXD80S-L
TXD100R Sponge	TXD100RA	100×100×25	TXD100R-H、TXD100R-L
TXD100S Sponge	TXD100SA	φ100×25	TXD100S-H、TXD100S-L
TXD120R Sponge	TXD120RA	120×120×25	TXD120R-H、TXD120R-L
TXD120S Sponge	TXD120SA	φ120×25	TXD120S-H、TXD120S-L

# TXC Series

**AIRBEST**

## Vacuum Gripper -Vacuum Generator Standard Type



UNIVERSAL

RoHS

### Features

- ◇ The housing is made of high quality aluminum alloy
- ◇ With built-in large flow vacuum generator
- ◇ Suction cup type and sponge type are optional for adsorption surface
- ◇ Built-in non-return valve can be selected

### Advantages

- ◇ High strength and light weight
- ◇ Fast reaction time
- ◇ Suitable for the handling of various industries
- ◇ It can meet the handling of different dimension workpieces



### Applications

- ◇ Mainly used in the packaging industry, such as intelligent warehousing, intelligent logistics, stacking and unstacking, unmanned sorting, etc.
- ◇ With built-in non-return valve, it can be used to adsorb the workpieces with certain leakage, different sizes and different shapes
- ◇ Because of its light weight, it is very suitable for robots

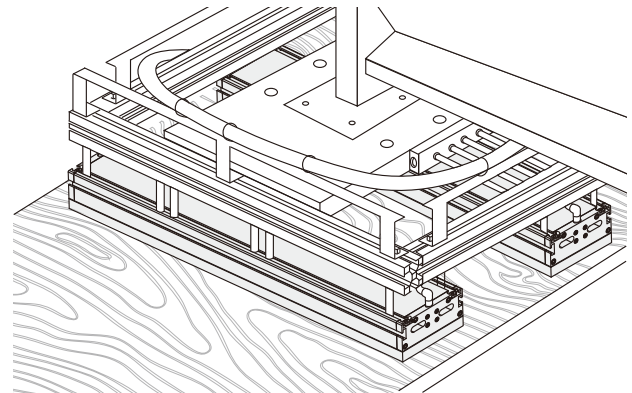

### Structure

- ◇ The main body is made of aluminum alloy, with T-shaped slots on the front and side respectively, which can be used for installation or mounting of the inductive switch
- ◇ It is equipped with Square-nut (M8 × 18 × 14 × 5.5)
- ◇ TXC130 × 400-800 has one air supply port (G1 / 4F) and six vacuum ports (6-G1 / 8F), direct exhaust from the side of the air supply end cover
- ◇ TXC130 × 1000-1200 has one air supply port (G1 / 4F) and four vacuum ports (4-G1 / 8F) at both end covers, direct exhaust from the side of the air supply end covers
- ◇ With built-in large flow vacuum generator, non-return valve is optional
- ◇ For sponge type, A1, A3, A5 sponge can be selected
- ◇ For suction cup type, B30, B40 can be selected

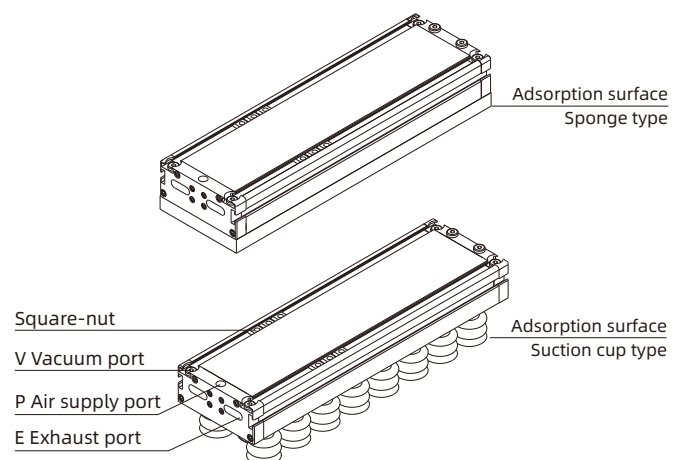

### How to order

## TXC 130×400 - A3 - V

①                      ②                      ③                      ④

① Series	② Dimension	③ Adsorption surface type	④ Non-return valve
TXC	130×400	A1 - Single row sponge holes	Nil - Default, Without non-return valve (Throttling hole structure)
	130×600	A3 - Three rows sponge holes	V - With non-return valve (Ball valve structure)
	130×800	A5 - Five rows sponge holes	VF - With non-return valve (Flap valve structure, reversible) only for sponge type
	130×1000	B30 - Suction cup type(suction cup dia.30mm)	
	130×1200	B40 - Suction cup type(suction cup dia.40mm)	
	130×1400		

### Selection-Standard type

Model/ Adsorption surface type	A1 - Single row sponge holes	A3 - Three rows sponge holes	A5 - Five rows sponge holes	B30 - Suction cup type	B40 - Suction cup type
TXC130×400-□	TXC130×400-A1	TXC130×400-A3	TXC130×400-A5	TXC130×400-B30	TXC130×400-B40
TXC130×600-□	TXC130×600-A1	TXC130×600-A3	TXC130×600-A5	TXC130×600-B30	TXC130×600-B40
TXC130×800-□	TXC130×800-A1	TXC130×800-A3	TXC130×800-A5	TXC130×800-B30	TXC130×800-B40
TXC130×1000-□	TXC130×1000-A1	TXC130×1000-A3	TXC130×1000-A5	TXC130×1000-B30	TXC130×1000-B40
TXC130×1200-□	TXC130×1200-A1	TXC130×1200-A3	TXC130×1200-A5	TXC130×1200-B30	TXC130×1200-B40
TXC130×1400-□	TXC130×1400-A1	TXC130×1400-A3	-	TXC130×1400-B30	TXC130×1400-B40

### Selection-With non-return valve

Model/ Adsorption surface type	A1 - Single row sponge holes	A3 - Three rows sponge holes	A5 - Five rows sponge holes	B30 - Suction cup type	B40 - Suction cup type
TXC130×400-□-V/VF	TXC130×400-A1-V/VF	TXC130×400-A3-V/VF	TXC130×400-A5-V/VF	TXC130×400-B30-V	TXC130×400-B40-V
TXC130×600-□-V/VF	TXC130×600-A1-V/VF	TXC130×600-A3-V/VF	TXC130×600-A5-V/VF	TXC130×600-B30-V	TXC130×600-B40-V
TXC130×800-□-V/VF	TXC130×800-A1-V/VF	TXC130×800-A3-V/VF	TXC130×800-A5-V/VF	TXC130×800-B30-V	TXC130×800-B40-V
TXC130×1000-□-V/VF	TXC130×1000-A1-V/VF	TXC130×1000-A3-V/VF	TXC130×1000-A5-V/VF	TXC130×1000-B30-V	TXC130×1000-B40-V
TXC130×1200-□-V/VF	TXC130×1200-A1-V/VF	TXC130×1200-A3-V/VF	TXC130×1200-A5-V/VF	TXC130×1200-B30-V	TXC130×1200-B40-V
TXC130×1400-□-V/VF	TXC130×1400-A1-V/VF	TXC130×1400-A3-V/VF	-	TXC130×1400-B30-V	TXC130×1400-B40-V

### Technical parameters

Model	Rated air supply pressure bar	Max.vacuum flow NL/min	Air consumption NL/min	Max.theoretical suction force N (-60kPa)	Weight kg V-with non- return valve	Recommended hose dia. mm	QTY of suction hole PCS
TXC130×400-A1	6.0	710	230	559	2.6	1×φ10	15
TXC130×600-A1	6.0	1,050	345	820	3.4	1×φ10	22
TXC130×800-A1	6.0	1,410	460	1,180	4.2	1×φ10	30
TXC130×1000-A1	6.0	1,760	575	1,379	5.4	2×φ10	37
TXC130×1200-A1	6.0	2,100	690	1,640	6.2	2×φ10	44
TXC130×1400-A1	6.0	2,460	805	1,901	7.4	2×φ10	52

## Vacuum Gripper -Vacuum Generator Standard Type

### Technical parameters

Model	Rated air supply pressure bar	Max.vacuum flow NL/min	Air consumption NL/min	Max.theoretical suction force N (-60kPa)	Weight KG V-with non-return valve	Recommended hose dia. mm	QTY of suction hole PCS
TXC130×400-A3	6.0	710	230	344	2.6	1×φ10	65
TXC130×600-A3	6.0	1,050	345	519	3.4	1×φ10	98
TXC130×800-A3	6.0	1,410	460	694	4.2	1×φ10	131
TXC130×1000-A3	6.0	1,760	575	869	5.4	2×φ10	164
TXC130×1200-A3	6.0	2,100	690	1,044	6.2	2×φ10	197
TXC130×1400-A3	6.0	2,460	805	1,219	7.4	2×φ10	230
TXC130×400-A5	6.0	1,050	345	347	2.6	1×φ10	108
TXC130×600-A5	6.0	1,410	460	530	3.4	1×φ10	165
TXC130×800-A5	6.0	1,760	575	707	4.2	1×φ10	220
TXC130×1000-A5	6.0	2,460	805	884	5.4	2×φ10	275
TXC130×1200-A5	6.0	2,810	920	1,061	6.2	2×φ10	330
TXC130×400-B30	6.0	710	230	588	3.3	1×φ10	28
TXC130×600-B30	6.0	1,050	345	903	4.3	1×φ10	43
TXC130×800-B30	6.0	1,410	460	1,155	5.4	1×φ10	55
TXC130×1000-B30	6.0	1,760	575	1,470	7.0	2×φ10	70
TXC130×1200-B30	6.0	2,100	690	1,785	8.1	2×φ10	85
TXC130×1400-B30	6.0	2,460	805	2,058	9.6	2×φ10	98
TXC130×400-B40	6.0	710	230	867	3.6	1×φ10	23
TXC130×600-B40	6.0	1,050	345	1,319	4.9	1×φ10	35
TXC130×800-B40	6.0	1,410	460	1,771	6.2	1×φ10	47
TXC130×1000-B40	6.0	1,760	575	2,224	7.9	2×φ10	59
TXC130×1200-B40	6.0	2,100	690	2,676	9.3	2×φ10	71
TXC130×1400-B40	6.0	2,460	805	3,129	10.9	2×φ10	83

◇ Note: The suction force in the above table is the theoretical suction force obtained under the condition that the vacuum gripper is fully covered by a rigid airtight workpiece, and without considering safety factor.

### Dimensions(mm)

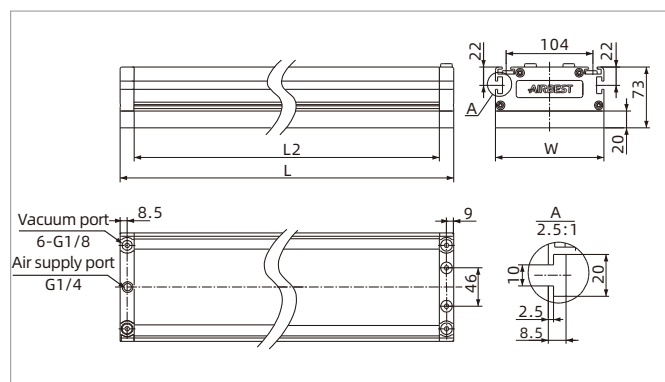

TXC130×400/600/800-A Sponge type

Model/Size	L	L2	W
TXC130×400-A	434	400	130
TXC130×600-A	634	600	130
TXC130×800-A	834	800	130

# TXC Series



## Vacuum Gripper - Vacuum Generator Standard Type

### Dimensions(mm)

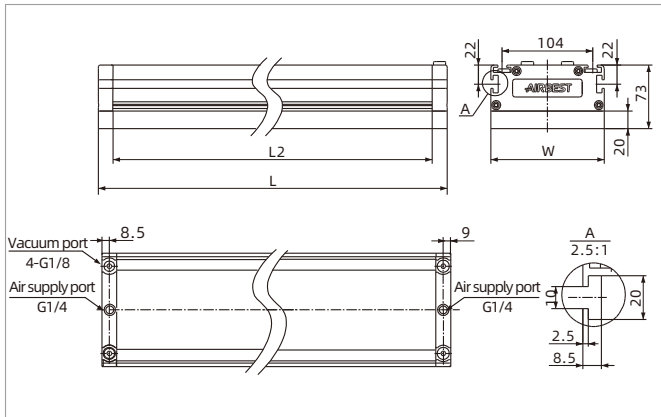

Model/Size	L	L2	W
TXC130×1000-A	1,034	1,000	130
TXC130×1200-A	1,234	1,200	130
TXC130×1400-A	1,434	1,400	130

TXC130×1000/1200/1400-A Sponge type

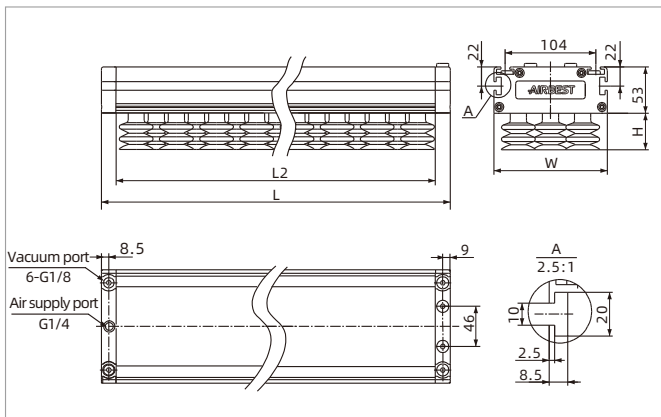

Model/Size	L	L2	W	B30	H B40
TXC130×400-B	434	400	130	37	45
TXC130×600-B	634	600	130	37	45
TXC130×800-B	834	800	130	37	45

TXC130×400/600/800-B Suction cup type

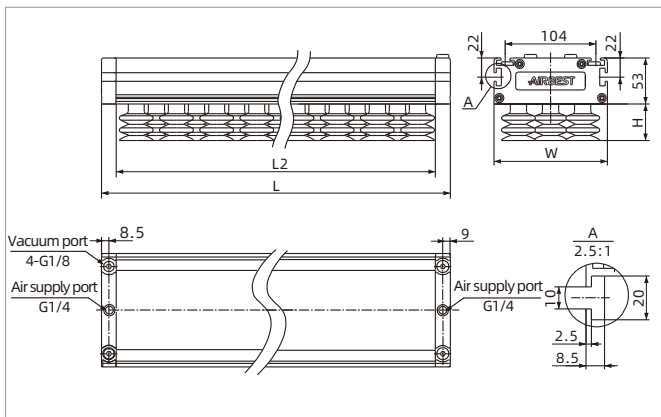

Model/Size	L	L2	W	B30	H B40
TXC130×1000-B	1,034	1,000	130	37	45
TXC130×1200-B	1,234	1,200	130	37	45
TXC130×1400-B	1,434	1,400	130	37	45

TXC130×1000/1200/1400-B Suction cup type

Vacuum gripper

TXN

TXD

**TXC**

TXM

TXP

TXH

TXL

# TXC Series



## Vacuum Gripper -Vacuum Generator Standard Type

### Spare parts selection(mm)

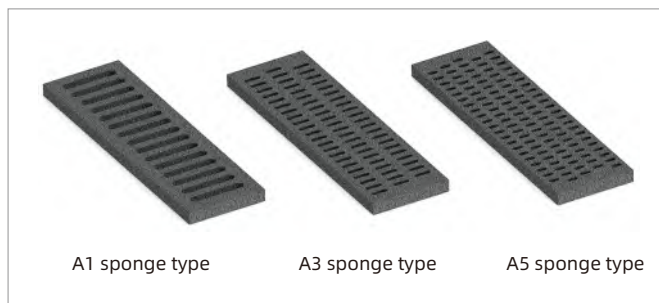

Sponge type

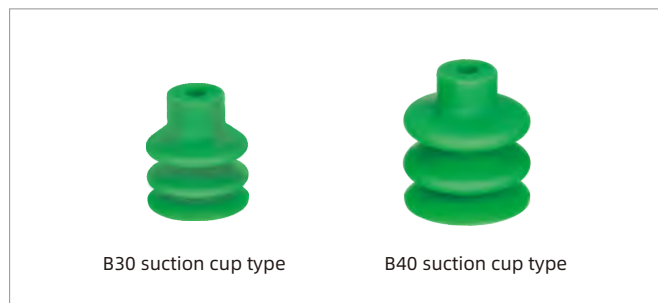

Suction cup type

### Spare parts selection

Item	Model	Dimension mm
Sponge	TXC400-A1, TXC400-A3, TXC400-A5	434×130×20
	TXC600-A1, TXC600-A3, TXC600-A5	634×130×20
	TXC800-A1, TXC800-A3, TXC800-A5	834×130×20
	TXC1000-A1, TXC1000-A3, TXC1000-A5	1034×130×20
	TXC1200-A1, TXC1200-A3, TXC1200-A5	1234×130×20
Suction cup	TXC1400-A1, TXC1400-A3,	1434×130×20
	SPC30S	φ30
	SPC40S	φ40

◇ Note: Sponges are consumables in this product. Please replace it in time according to actual working conditions, otherwise, it will affect the adsorption effect.  
Operating temperature: - 10 ~ 60 °C, do not contact with strong acid, strong alkali and other corrosive gas or liquid, do not contact with sharp objects.

# TXM Series

## Vacuum Gripper-Blower Standard Type



UNIVERSAL



### Features

- ◇ The housing is made of high quality aluminum alloy
- ◇ External vacuum generator or blower can be connected
- ◇ Suction cup type and sponge type are optional for adsorption surface
- ◇ Built-in non-return valve can be selected

### Advantages

- ◇ High strength and light weight
- ◇ The vacuum source can be selected accurately according to the actual working condition
- ◇ Suitable for the handling of various industries
- ◇ It can meet the handling of different dimension workpieces



### Applications

- ◇ Mainly used in the packaging industry, such as intelligent warehousing, intelligent logistics, stacking and unstacking, unmanned sorting, etc.
- ◇ With built-in non-return valve, it can be used to adsorb the workpieces with certain leakage, different sizes and different shapes
- ◇ Because of its light weight, it is very suitable for robots

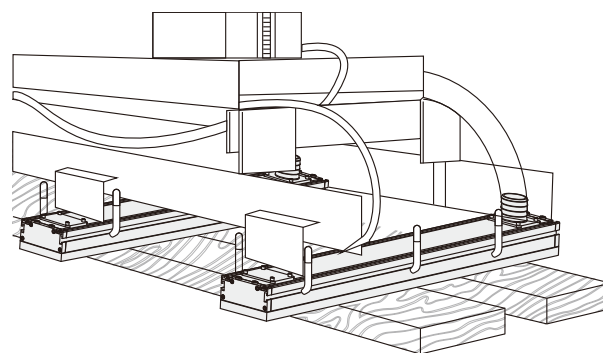

Vacuum gripper

- TXN
- TXD
- TXC
- TXM**
- TXP
- TXH
- TXL

### Structure

- ◇ The main body is made of aluminum alloy, with T-shaped slots on the front and side respectively, which can be used for installation or mounting of the inductive switch
- ◇ It is equipped with Square-nut (M8 × 18 × 14 × 5.5)
- ◇ The gripper has one vacuum port and 8 vacuum detecting ports (8-G1/8F). The vacuum port can connect to external steel wire hose
- ◇ Non-return valve is optional
- ◇ For sponge type, A1, A3, A5 sponge can be selected
- ◇ For suction cup type, B30, B40 can be selected

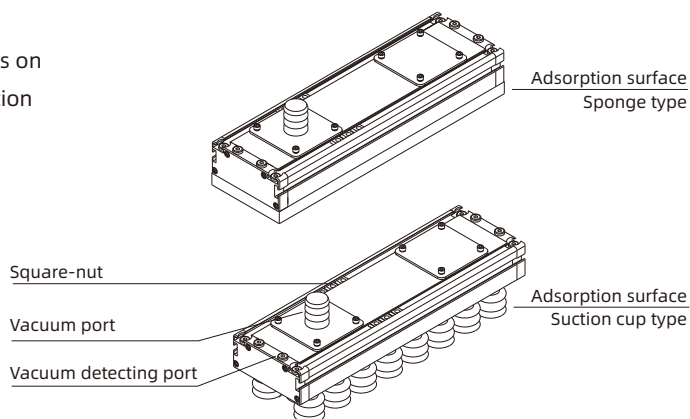

## Vacuum Gripper-Blower Standard Type

### How to order

TXM 130×400 - A3 - V  
①      ②      ③      ④

① Series	② Dimension	③ Adsorption surface type	④ Non-return valve
TXM	130×400	A1 - Single row sponge holes	Nil - Default, Without non-return valve (Throttling hole structure)
	130×600	A3 - Three rows sponge holes	
	130×800	A5 - Five rows sponge holes	V - With non-return valve (Ball valve structure)
	130×1000	B30 - Suction cup type(suction cup dia.30mm)	
	130×1200	B40 - Suction cup type(suction cup dia.40mm)	
	130×1400		

### Selection-Standard type

Model/ Adsorption surface type	A1 - Single row sponge holes	A3 - Three rows sponge holes	A5 - Five rows sponge holes	B30 - Suction cup type	B40 - Suction cup type
TXM130×400-□	TXM130×400-A1	TXM130×400-A3	TXM130×400-A5	TXM130×400-B30	TXM130×400-B40
TXM130×600-□	TXM130×600-A1	TXM130×600-A3	TXM130×600-A5	TXM130×600-B30	TXM130×600-B40
TXM130×800-□	TXM130×800-A1	TXM130×800-A3	TXM130×800-A5	TXM130×800-B30	TXM130×800-B40
TXM130×1000-□	TXM130×1000-A1	TXM130×1000-A3	TXM130×1000-A5	TXM130×1000-B30	TXM130×1000-B40
TXM130×1200-□	TXM130×1200-A1	TXM130×1200-A3	TXM130×1200-A5	TXM130×1200-B30	TXM130×1200-B40
TXM130×1400-□	TXM130×1400-A1	TXM130×1400-A3	TXM130×1400-A5	TXM130×1400-B30	TXM130×1400-B40

### Selection-With non-return valve

Model/ Adsorption surface type	A1 - Single row sponge holes	A3 - Three rows sponge holes	A5 - Five rows sponge holes	B30 - Suction cup type	B40 - Suction cup type
TXM130×400-□-V	TXM130×400-A1-V	TXM130×400-A3-V	TXM130×400-A5-V	TXM130×400-B30-V	TXM130×400-B40-V
TXM130×600-□-V	TXM130×600-A1-V	TXM130×600-A3-V	TXM130×600-A5-V	TXM130×600-B30-V	TXM130×600-B40-V
TXM130×800-□-V	TXM130×800-A1-V	TXM130×800-A3-V	TXM130×800-A5-V	TXM130×800-B30-V	TXM130×800-B40-V
TXM130×1000-□-V	TXM130×1000-A1-V	TXM130×1000-A3-V	TXM130×1000-A5-V	TXM130×1000-B30-V	TXM130×1000-B40-V
TXM130×1200-□-V	TXM130×1200-A1-V	TXM130×1200-A3-V	TXM130×1200-A5-V	TXM130×1200-B30-V	TXM130×1200-B40-V
TXM130×1400-□-V	TXM130×1400-A1-V	TXM130×1400-A3-V	TXM130×1400-A5-V	TXM130×1400-B30-V	TXM130×1400-B40-V

### Technical parameters

Model	Max.theoretical suction force N (-30kPa)	Max.theoretical suction force N (-40kPa)	Max.theoretical suction force N (-50kPa)	Max.theoretical suction force N (-60kPa)	Weight kg V-with non- return valve	Blower connection port dia. mm	QTY of suction hole PCS
TXM130×400-A1	280	373	465	559	2.3	φ32	15
TXM130×600-A1	410	546	683	820	3.1	φ32	22
TXM130×800-A1	590	787	984	1,180	3.9	φ60	30
TXM130×1000-A1	690	919	1,149	1,379	4.6	φ60	37
TXM130×1200-A1	820	1,093	1,367	1,640	5.4	φ60	44
TXM130×1400-A1	951	1,267	1,584	1,901	6.6	φ60	52

# TXM Series



## Vacuum Gripper-Blower Standard Type

### Technical parameters

Model	Max.theoretical suction force N (-30kPa)	Max.theoretical suction force N (-40kPa)	Max.theoretical suction force N (-50kPa)	Max.theoretical suction force N (-60kPa)	Weight kg V-with non-return valve	Blower connection port dia. mm	QTY of suction hole PCS
TXM130×400-A3	169	227	286	344	2.3	φ32	65
TXM130×600-A3	254	343	431	519	3.1	φ32	98
TXM130×800-A3	340	458	576	694	3.9	φ60	131
TXM130×1000-A3	426	574	721	869	4.6	φ60	164
TXM130×1200-A3	512	689	866	1,044	5.4	φ60	197
TXM130×1400-A3	598	805	1,012	1,219	6.6	φ60	230
TXM130×400-A5	170	226	283	340	2.3	φ32	108
TXM130×600-A5	255	340	425	510	3.1	φ32	165
TXM130×800-A5	335	447	558	670	3.9	φ60	220
TXM130×1000-A5	435	580	725	870	4.6	φ60	275
TXM130×1200-A5	505	673	842	1,010	5.4	φ60	330
TXM130×1400-A5	590	787	983	1,180	6.6	φ60	385
TXM130×400-B30	294	392	490	588	3.1	φ32	28
TXM130×600-B30	451	602	752	903	4.1	φ32	43
TXM130×800-B30	577	770	962	1,155	5.3	φ60	55
TXM130×1000-B30	735	980	1,225	1,470	6.2	φ60	70
TXM130×1200-B30	892	1,190	1,487	1,785	7.3	φ60	85
TXM130×1400-B30	1,029	1,372	1,715	2,058	8.8	φ60	98
TXM130×400-B40	432	575	722	867	3.3	φ32	23
TXM130×600-B40	658	875	1,099	1,319	4.6	φ32	35
TXM130×800-B40	883	1,175	1,475	1,771	6.0	φ60	47
TXM130×1000-B40	1,109	1,475	1,852	2,224	7.1	φ60	59
TXM130×1200-B40	1,334	1,775	2,229	2,676	8.5	φ60	71
TXM130×1400-B40	1,560	2,075	2,606	3,129	10.1	φ60	83

◇ Note: The suction force in the above table is the theoretical suction force obtained under the condition that the vacuum gripper is fully covered by a rigid airtight workpiece, and without considering safety factor.

### Dimensions(mm)

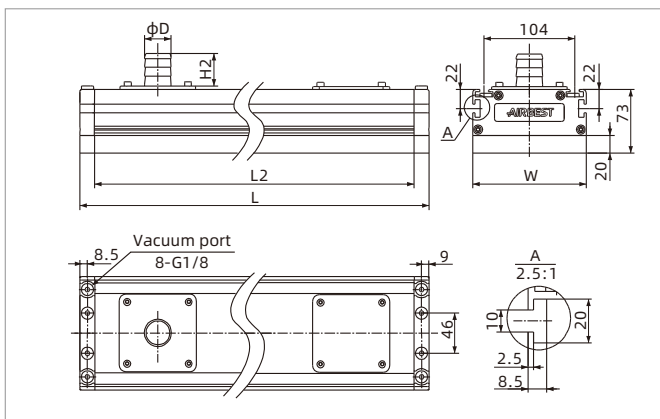

TXM130×400(600-1400)-A Sponge type

Model/Size	L	L2	W	D	H2
TXM130×400-A	434	400	130	33	40
TXM130×600-A	634	600	130	33	40
TXM130×800-A	834	800	130	61	50
TXM130×1000-A	1,034	1,000	130	61	50
TXM130×1200-A	1,234	1,200	130	61	50
TXM130×1400-A	1,434	1,400	130	61	50

Vacuum gripper

TXN

TXD

TXC

**TXM**

TXP

TXH

TXL

# TXM Series



## Vacuum Gripper-Blower Standard Type

### Dimensions(mm)

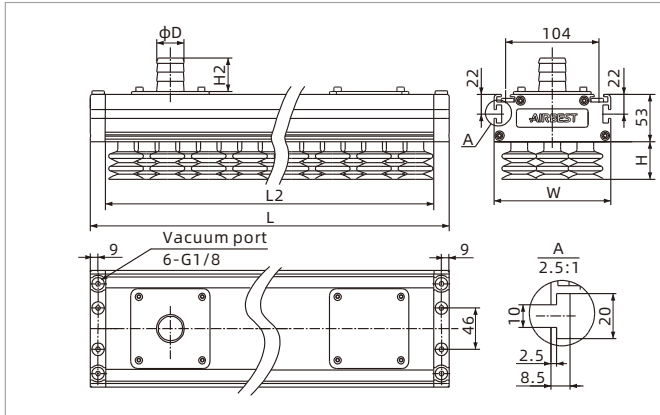

TXM130×400(600-1400)-B Suction cup type

Model/size	L	L2	W	D	H2	H	
						B30	B40
TXM130×400-B	434	400	130	33	40	37	45
TXM130×600-B	634	600	130	33	40	37	45
TXM130×800-B	834	800	130	61	50	37	45
TXM130×1000-B	1,034	1,000	130	61	50	37	45
TXM130×1200-B	1,234	1,200	130	61	50	37	45
TXM130×1400-B	1,434	1,400	130	61	50	37	45

### Spare parts selection(mm)

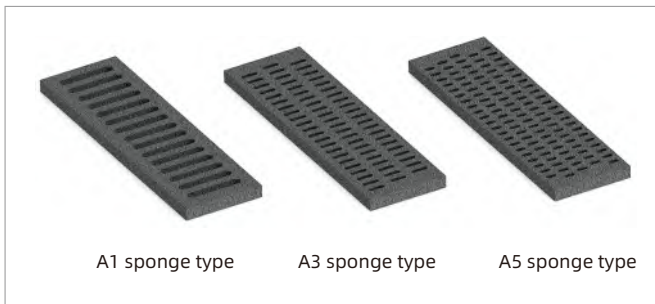

Sponge type

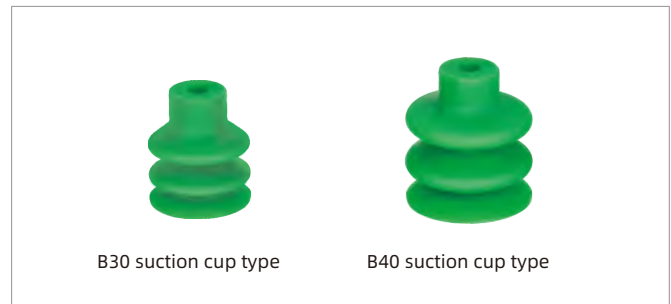

Suction cup type

### Spare parts selection

Item	Model	Dimension mm
Sponge	TXC400-A1, TXC400-A3, TXC400-A5	434×130×20
	TXC600-A1, TXC600-A3, TXC600-A5	634×130×20
	TXC800-A1, TXC800-A3, TXC800-A5	834×130×20
	TXC1000-A1, TXC1000-A3, TXC1000-A5	1034×130×20
	TXC1200-A1, TXC1200-A3, TXC1200-A5	1234×130×20
	TXC1400-A1, TXC1400-A3, TXC1400-A5	1434×130×20
Suction cup	SPC30S	φ30
	SPC40S	φ40

◇ Note: Sponges are consumables in this product. Please replace it in time according to actual working conditions, otherwise, it will affect the adsorption effect.  
Operating temperature: - 10 ~ 60 °C, do not contact with strong acid, strong alkali and other corrosive gas or liquid, do not contact with sharp objects.

# TXP Series

## Vacuum Gripper-Oval Shaped



PACKAGING

### Features

- ◇ The housing is made of high quality stainless steel
- ◇ External blower is used for vacuum source
- ◇ Large inside area structure

### Advantages

- ◇ High strength, mainly used in high load working conditions
- ◇ Achieve stable and fast handling of products
- ◇ Maximize the suction force by increasing the adsorption area

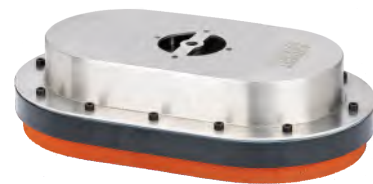

### Applications

- ◇ Mainly used for handling objects with large deformation, serious concave and convex surface and certain air permeability under high load conditions, such as flour bags, rice bags, cement bags and so on

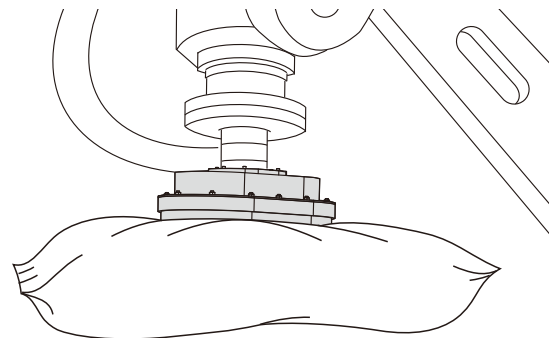

Vacuum gripper

- TXN
- TXD
- TXC
- TXM
- TXP**
- TXH
- TXL

### Structure

- ◇ The housing is made of stainless steel, and the flange mounting hole is reserved at the top
- ◇ Large area oval cavity structure design
- ◇ Foam rubber is used for adsorption with good sealing and long lifetime.  
The foam rubber can be purchased separately and replaced by users themselves

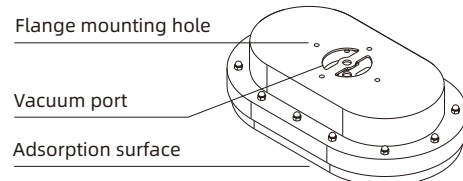
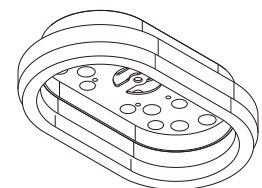

# TXP Series

## Vacuum Gripper-Oval Shaped

### How to order

## TXP 230×380 - A

①                      ②                      ③

① Series	② Dimension	③ Adsorption surface type
TXP	190×290 230×380	A - Foam rubber

### Technical parameters

Model	Recommended blower flow m <sup>3</sup> /h	Max.theoretical suction force N (-40kPa)	Weight kg	Recommended hose dia. of blower mm
TXP190×290-A	200	860	2.9	φ60
TXP230×380-A	200	1,440	4.0	φ60

◇ Note: The suction force in the above table is the theoretical suction force obtained under the condition that the vacuum gripper is fully covered by a rigid airtight workpiece, and without considering safety factor.

### Dimensions(mm)

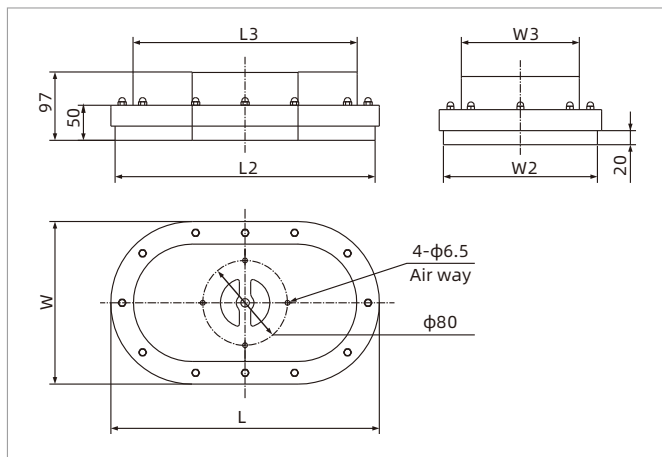

Model/size	W	W2	W3	L	L2	L3
TXP190×290-A	200	190	132	300	280	236
TXP230×380-A	228	220	164	378	360	314

TXP

### Spare parts selection

Item	Model	Applicable vacuum gripper
Foam rubber	TXP190	TXP190×290-A
	TXP230	TXP230×380-A

# TXH Series

## Vacuum Gripper-Heavy Load Type



UNIVERSAL HEAVY LOAD



### Features

- ◇ Large area structure design
- ◇ Vacuum source can be built-in vacuum generator or external blower
- ◇ Suction cup type and sponge type are optional for adsorption surface
- ◇ Built-in non-return valve structure

### Advantages

- ◇ Large area adsorption structure, mainly used in high load working conditions
- ◇ Customers can select flexibly according to the actual working conditions
- ◇ Suitable for the handling of various industries
- ◇ It can meet the handling of different dimension workpieces



### Applications

- ◇ Mainly used in heavy load sorting system, intelligent warehousing, stacking and unstacking, logistics, etc.

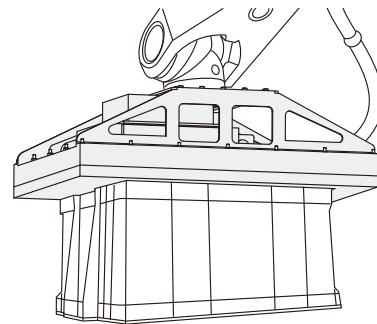

Vacuum gripper

- TXN
- TXD
- TXC
- TXM
- TXP
- TXH**
- TXL

### How to order

TXH 500×700 - A - C - V  
①   
②   
③   
④   
⑤

① Series	② Dimension	③ Adsorption surface type	④ Vacuum source	⑤ Non-return valve
TXH	500×700	A - Sponge	Nil - Without vacuum source	V-with non-return valve
	800×1000	B40 - Suction cup	C - With external vacuum generator	
	1100×1300			

### Selection

Model/Adsorption surface type	A - Sponge	B40 - Suction cup
TXH500×700-□-C-V	TXH500×700-A-C-V	-
TXH800×1000-□-V	TXH800×1000-A-V	TXH800×1000-B40-V
TXH1100×1300-□-V	TXH1100×1300-A-V	TXH1100×1300-B40-V

# TXH500×700-A-C-V

## Vacuum Gripper-Heavy Load Type

### Features

- ◇ Large area handling, heavy load application
- ◇ Built-in large flow vacuum generator, fast reaction time
- ◇ Built-in non-return valve structure, which can meet the handling of various dimension workpieces
- ◇ The adsorption surface is sponge
- ◇ Mainly used in sorting system, stacking and unstacking industry



### Technical parameters

Model	Rated air supply pressure bar	Max.vacuum level -kPa	Max.vacuum flow NL/min	Air consumption NL/min	Max.theoretical suction force N (-40kPa)	Mounting bracket	Weight kg	Recommended hose dia. mm Air supply port (P)
TXH500×700-A-C-V	6.0	85	3,710	2,300	1,440	with	36.5	φ16

- ◇ Note: 1. The detecting device includes 1 mechanical negative pressure gauge, 1 digital pressure gauge and 1 photoelectric inductive switch, and NPN output
- 2. The data of theoretical suction force as above are figured out in the condition that the gripper is fully covered by rigid airtight workpieces without considering safety factor.

### Dimensions(mm)

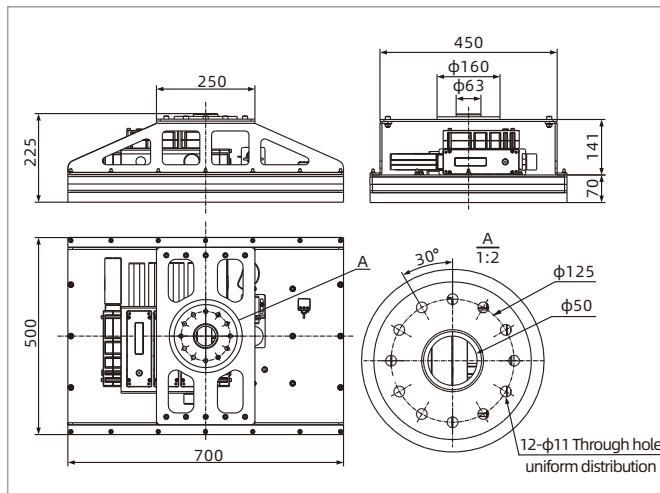

TXH500×700-A-C-V

### Spare parts selection

Item	Model	Dimension mm	Applicable vacuum gripper
Sponge	TXH500×700	500×700×25	TXH500×700-A-C-V

# TXH500×700-A-V



## Vacuum Gripper-Heavy Load Type

### Features

- ◇ Applicable for packaging and logistics industry, such as box handling, stacking and unstacking. High quality sponge fits the uneven surface perfectly with the performance of long lifetime and good sealing. The vacuum source is external blower. It is equipped with built-in check valve and reversing valve control unit for blower. The vacuum detecting switch and approach switch are equipped as well to provide convenience for automatic control systems



### Technical parameters

Model	Max.theoretical suction force N (-40kPa)	Recommended blower flow m <sup>3</sup> /h	Working voltage of control unit V	Reverser for blower	Mounting bracket	Weight kg	Blower connection port dia. mm
TXH500×700-A-V	1,440	170	DC24V	with	without	36.5	φ60

- ◇ Note: 1. The detecting device includes 1 mechanical negative pressure gauge, 1 digital pressure gauge and 1 photoelectric inductive switch.
- 2. The data of theoretical suction force as above are figured out in the condition that the gripper is fully covered by rigid airtight workpieces without considering safety factor.

### Dimensions(mm)

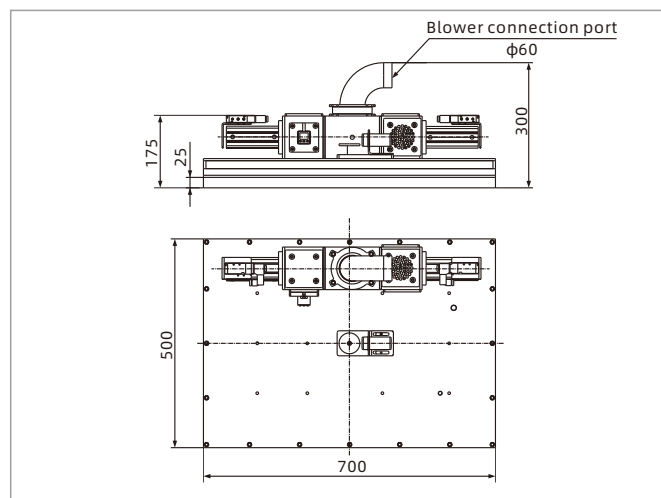

TXH500×700-A-V

### Spare parts selection

Item	Model	Dimension mm	Applicable vacuum gripper
Sponge	TXH500×700	500×700×25	TXH500×700-A-V

Vacuum gripper

- TXN
- TXD
- TXC
- TXM
- TXP
- TXH**
- TXL

# TXH800×1000-B40-V

## Vacuum Gripper-Heavy Load Type

### Features

- ◇ Applicable for packaging and logistics industry, such as box handling, stacking and unstacking. High quality sponge fits the uneven surface perfectly with the performance of long lifetime and good sealing. The vacuum source is external blower. It is equipped with built-in check valve and reversing valve control unit for blower. The vacuum detecting switch and approach switch are equipped as well to provide convenience for automatic control systems

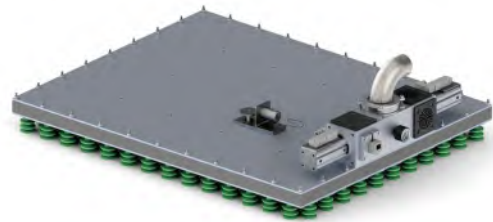

### Technical parameters

Model	Max.theoretical suction force N (-40kPa)	Recommended blower flow m <sup>3</sup> /h	Working voltage of control unit V	Reverser for blower	Mounting bracket	Weight kg	Blower connection port dia. mm
TXH800×1000-B40-V	3,850	320	DC24V	with	without	56	φ60
TXH1100×1300-B40-V	5,200	520	DC24V	with	without	79	φ60

- ◇ Note: 1. The detecting device includes 1 mechanical negative pressure gauge, 1 digital pressure gauge and 1 photoelectric inductive switch.
- 2. The data of theoretical suction force as above are figured out in the condition that the gripper is fully covered by rigid airtight workpieces without considering safety factor.

### Dimensions(mm)

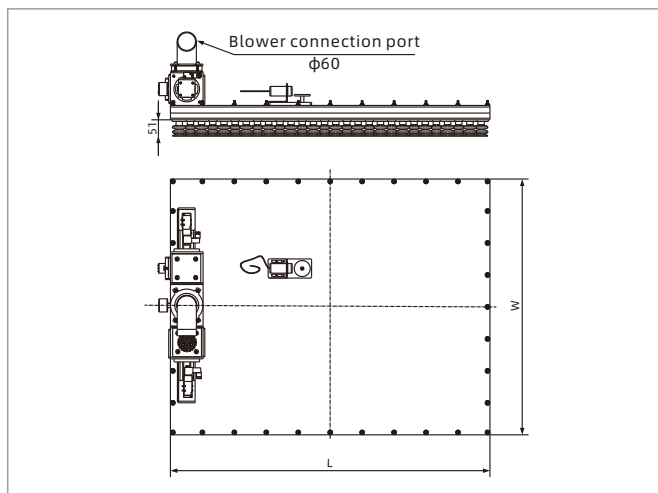

Model/Size	W	L
TXH800×1000-B40-V	800	1,000
TXH1100×1300-B40-V	1,100	1,300

TXH800×1000-B40-V TXH1100×1300-B40-V

### Spare parts selection

Item	Model	Dimension mm	Applicable vacuum gripper
Sponge	TXH800×1000	800×1000×25	TXH800×1000-A-V
	TXH1100×1300	1100×1300×25	TXH1100×1300-A-V
Suction cup	SPC40S	φ40	TXH800×1000-B40-V、TXH1100×1300-B40-V

# TXL Series

## Vacuum Gripper -Combined Type



UNIVERSAL



### Features

- ◇ The product is of modular structure
- ◇ The housing is made of high quality aluminum alloy
- ◇ Built -in large flow vacuum generator and external blower are optional
- ◇ Suction cup type and sponge type are optional for adsorption surface
- ◇ Built-in non-return valve can be selected

### Advantages

- ◇ Different sizes can be combined freely
- ◇ High strength and light weight
- ◇ Fast reaction time
- ◇ Suitable for the handling of various industries
- ◇ It can meet the handling of different dimension workpieces

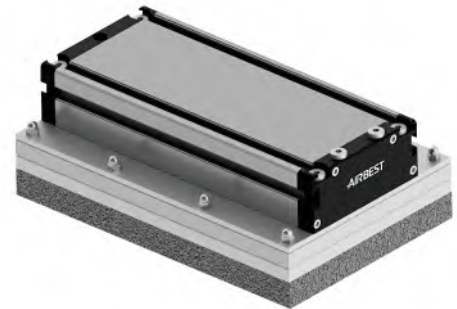

### Applications

- ◇ Mainly used in the packaging industry, such as intelligent warehousing, intelligent logistics, stacking and unstacking, unmanned sorting, etc.
- ◇ With built-in non-return valve, it can be used to adsorb the workpieces with certain leakage, different sizes and different shapes
- ◇ Because of its light weight, it is very suitable for robots

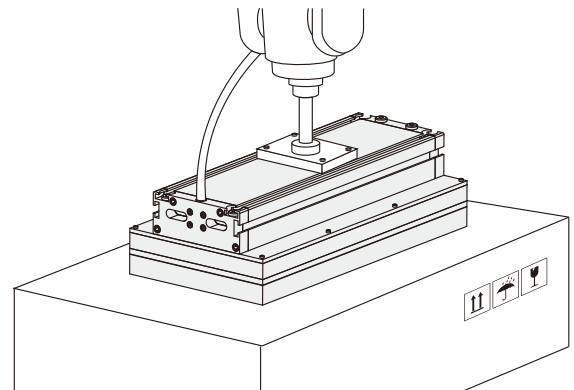

Vacuum gripper

- TXN
- TXD
- TXC
- TXM
- TXP
- TXH
- TXL**

### Structure

- ◇ The main body is made of aluminum alloy, with T-shaped slots on the front and side respectively, which can be used for installation or mounting of the inductive switch
- ◇ It is equipped with Square-nut (M8 × 18 × 14 × 5.5)
- ◇ The gripper has one air supply port (G1/4F) and six vacuum ports (6-G1/8F),direct exhaust from the side of the air supply end cover
- ◇ Built-in vacuum generator type and external blower type can be selected
- ◇ Non-return valve is optional

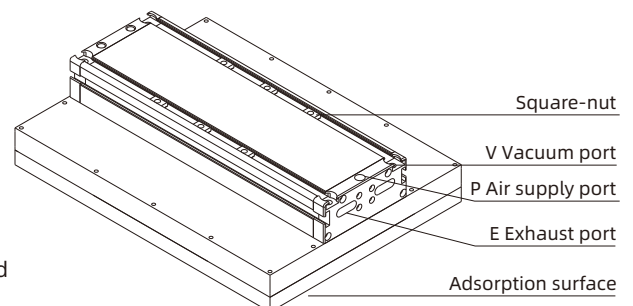

### How to order

TXL 200×300 - A - C - V  
①   
②   
③   
④   
⑤

① Series	② Dimension	③ Adsorption surface type	④ Vacuum source type	⑤ Non-return valve
TXL	200×300	A - sponge type	Nil-Blower type	Nil - Default, Without non-return valve
	200×400	B40 - suction cup type	C-Built-in vacuum generator	(Throttling hole structure)
	300×300			V - With non-return valve
	300×400			(Ball valve structure)

### Selection-Vacuum generator type

Model/Adsorption surface type	A - Sponge type	B - Suction cup type
TXL200×300-□-C	TXL200×300-A-C	TXL200×300-B40-C
TXL200×300-□-C-V	TXL200×300-A-C-V	TXL200×300-B40-C-V
TXL200×400-□-C	TXL200×400-A-C	TXL200×400-B40-C
TXL200×400-□-C-V	TXL200×400-A-C-V	TXL200×400-B40-C-V
TXL300×300-□-C	TXL300×300-A-C	TXL300×300-B40-C
TXL300×300-□-C-V	TXL300×300-A-C-V	TXL300×300-B40-C-V
TXL300×400-□-C	TXL300×400-A-C	TXL300×400-B40-C
TXL300×400-□-C-V	TXL300×400-A-C-V	TXL300×400-B40-C-V

### Selection-Blower type

Model/Adsorption surface type	A - Sponge type	B - Suction cup type
TXL200×300-□	TXL200×300-A	TXL200×300-B40
TXL200×300-□-V	TXL200×300-A-V	TXL200×300-B40-V
TXL200×400-□	TXL200×400-A	TXL200×400-B40
TXL200×400-□-V	TXL200×400-A-V	TXL200×400-B40-V
TXL300×300-□	TXL300×300-A	TXL300×300-B40
TXL300×300-□-V	TXL300×300-A-V	TXL300×300-B40-V
TXL300×400-□	TXL300×400-A	TXL300×400-B40
TXL300×400-□-V	TXL300×400-A-V	TXL300×400-B40-V

### Technical parameters-Vacuum generator type

Model	Rated air supply pressure bar	Max. vacuum flow NL/min	Air consumption NL/min	Max. theoretical suction force N (-60kPa)	Weight (kg) V-with non-return valve	Recommended hose dia. mm	QTY of suction hole PCS
TXL200×300-A-C	6.0	1,050	345	415	4.1	1×φ10	126
TXL200×400-A-C	6.0	1,410	460	563	5.2	1×φ10	171
TXL300×300-A-C	6.0	1,410	460	646	5.8	1×φ10	196
TXL300×400-A-C	6.0	1,410	460	874	8.4	1×φ10	266
TXL200×300-B40-C	6.0	1,050	345	1,055	4.6	1×φ10	28
TXL200×400-B40-C	6.0	1,050	345	1,432	6.1	1×φ10	38
TXL300×300-B40-C	6.0	1,050	345	1,469	6.8	1×φ10	39
TXL300×400-B40-C	6.0	1,050	345	1,997	9.4	1×φ10	53

# TXL Series



## Vacuum Gripper - Combined Type

### Technical parameters-Blower type

Model	Max.theoretical suction force N (-30kPa)	Max.theoretical suction force N (-40kPa)	Max.theoretical suction force N (-50kPa)	Max.theoretical suction force N (-60kPa)	Weight (kg) V-with non-return valve	Blower connection port dia. mm	QTY of suction hole PCS
TXL200×300-A-□	208	277	346	415	3.8	φ60	126
TXL200×400-A-□	282	375	469	563	4.9	φ60	171
TXL300×300-A-□	323	431	538	646	5.5	φ60	196
TXL300×400-A-□	437	583	728	874	8.1	φ60	266
TXL200×300-B40-□	526	701	879	1,055	4.3	φ60	28
TXL200×400-B40-□	714	950	1,193	1,432	5.8	φ60	38
TXL300×300-B40-□	733	975	1,224	1,469	6.5	φ60	39
TXL300×400-B40-□	996	1,325	1,664	1,997	9.1	φ60	53

◇ Note: The suction force in the above table is the theoretical suction force obtained under the condition that the vacuum gripper is fully covered by a rigid airtight workpiece, and without considering safety factor.

### Dimensions(mm)

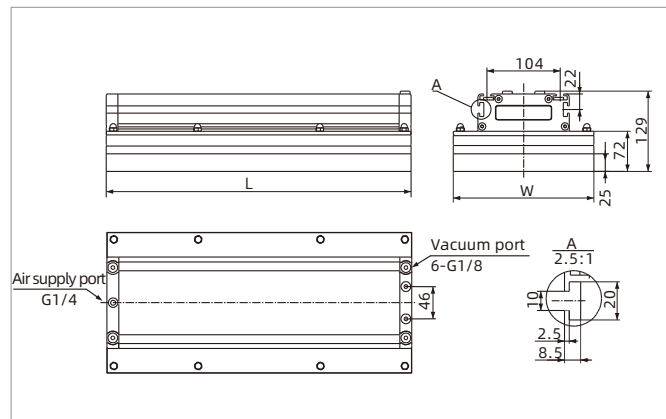

TXL Sponge type

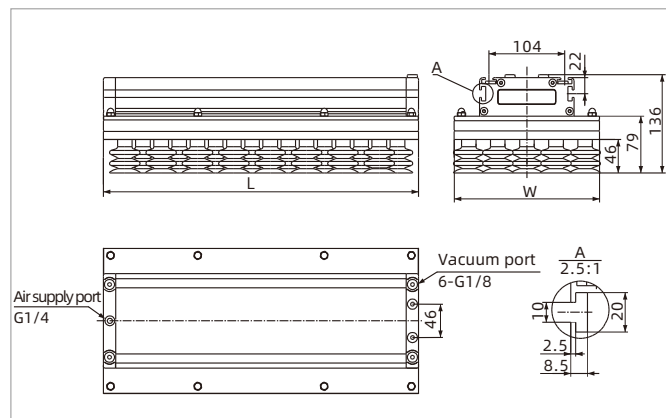

TXL Suction cup type

Model/Size	L	W
TXL200×300-A-□	300	200
TXL200×400-A-□	400	200
TXL300×300-A-□	300	300
TXL300×400-A-□	400	300

Model/Size	L	W
TXL200×300-B40-□	300	200
TXL200×400-B40-□	400	200
TXL300×300-B40-□	300	300
TXL300×400-B40-□	400	300

Vacuum gripper

- TXN
- TXD
- TXC
- TXM
- TXP
- TXH
- TXL

# TXL Series

## Vacuum Gripper -Combined Type

### Spare parts selection(mm)

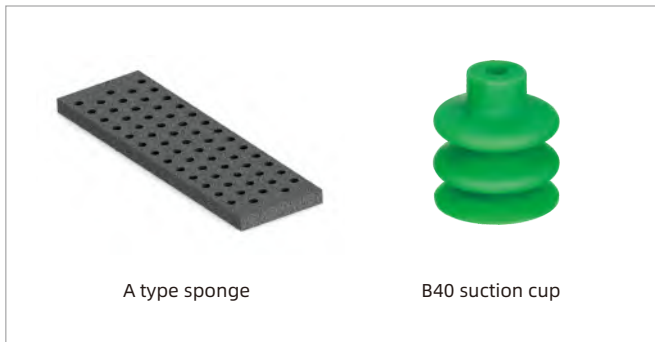

### Spare parts selection

Item	Model	Dimension mm
Sponge	TXL200×300-A5	200×300×25
	TXL200×400-A5	200×400×25
	TXL300×300-A5	300×300×25
	TXL300×400-A5	300×400×25
Suction cup	SPC40S	φ40

### Example of modular

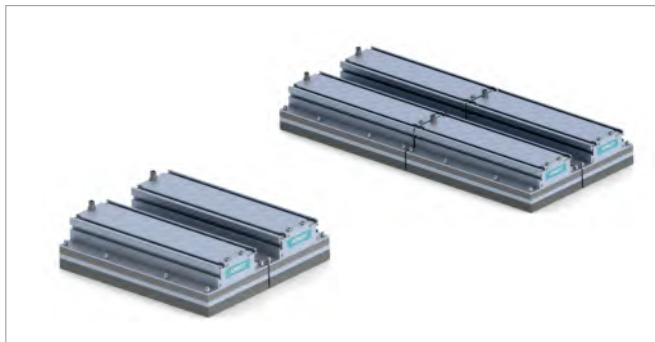

### Selection remark:

1. In the selection of gripper series products, it is necessary to carefully check the operating conditions, and select a suitable gripper model according to the different features of the grabbing workpiece.
2. In the selection manual, the gripper which is driven by vacuum generator, is required to use clean and dry compressed air.
3. In the selection manual, for the gripper products driven by the blowers, select a suitable model of the blowers according to the recommendation. All products in the selection manual do not include the blower, the blower has to be purchased by the customer separately.
4. The air supply pressure in the selection manual refers to the air supply pressure of the product under the operating condition. It is recommended that the fluctuation range of the operating pressure value is within  $\pm 10\%$  of the air supply pressure standard value.
5. The theoretical maximum suction value in the selection manual is the recommended value calculated according to the theory of grabbing specific workpieces under the specific vacuum level. It is only the reference for the gripper selection, and not the only basis for grabbing any workpieces by the gripper.
6. All models of the products in the manual can only work under normal temperature and pressure. If there is a need for use in special environment (high temperature, high humidity, high oil pollution, high dust, corrosiveness, radioactivity, etc.), please contact the company's customer service for consultation.
7. All products in the selection manual have rated life. The rated life of each product is determined by the surface roughness, material, hardness, working condition environment, use frequency and other factors. Customers can contact the company's customer service according to the specific application conditions.
8. In order to prolong the operation life of the adsorption surface (sponge / rubber suction cup) of the gripper, it is suggested that the normal use method: when grabbing the workpiece, first contact closely the workpiece, and then open the vacuum; When placing the workpiece, first stabilize the workpiece, and then turn off the vacuum.
9. In order to improve product quality and customer experience, we will continuously improve the product, and inform customers of the update information in time.

## **F** Mounting parts

# Mounting Parts

## Products overview

### Mounting Parts

#### 407 PSPE Series

##### Small and Light Level Compensator

- ◇ Connection thread: M5 M8
- ◇ Buffer stroke: 6~50mm



ELECTRONICS



#### 423 PSPD Series

##### Double Springs Heavy-duty Compensator

- ◇ Connection thread: G1/4  
G3/8 G1/2
- ◇ Buffer stroke: 25~90mm



UNIVERSAL HEAVY LOAD



#### 411 PSPL Series

##### Retractive Level Compensator

- ◇ Connection thread: M5
- ◇ Buffer stroke: 3~20mm



ELECTRONICS



#### 426 PSPF Series

##### Compact Level Compensator

- ◇ Connection thread: M5 M8 G1/8
- ◇ Buffer stroke: 10~50mm



ELECTRONICS



#### 413 PPS Series

##### Retractive Level Compensator

- ◇ Connection thread: M10
- ◇ Buffer stroke: 10~20mm



UNIVERSAL



#### 429 PJS Series

##### Fitting For Suction Cup

- ◇ Connection thread: M5 G1/8  
G1/4 G3/8
- ◇ Special specification: EW EH



UNIVERSAL



#### 416 PSPT Series

##### Universal Level Compensator

- ◇ Connection thread: G1/8  
G1/4 G3/8
- ◇ Buffer stroke: 10~110mm



UNIVERSAL



#### 433 PJT Series

##### Universal Mounting Parts-Adapter

- ◇ Connection thread: M5 M8  
G1/8 G1/4 G3/8 G1/2



UNIVERSAL



#### 420 PSPH Series

##### Heavy-duty Level Compensator

- ◇ Connection thread: G1/4  
G3/8 G1/2
- ◇ Buffer stroke: 25~90mm



UNIVERSAL HEAVY LOAD



#### 435 PJF Series

##### Universal Mounting Parts-Locking Fitting

- ◇ Connection thread: M5 M8 G1/8



UNIVERSAL



# Mounting Parts

## Products overview

### Mounting Parts

#### 437 PJB Series

##### Universal Mounting Parts-Ball Joint

- ◇ Connection thread: M10 G1/8  
G1/2 G1/4



UNIVERSAL



RoHS

#### 439 PJH Series

##### Universal Mounting Parts-Flexible Joint

- ◇ Connection thread: G1/4 G3/8
- ◇ Max.deflection angle: 15°



UNIVERSAL



RoHS

#### 438 PJE Series

##### Universal Mounting Parts-Flexible Joint

- ◇ Vacuum connection thread:  
G1/4 G1/2
- ◇ Max.deflection angle: 12°



UNIVERSAL



RoHS

# PSPE Series

## Small and Light Level Compensator

AIRBEST



ELECTRONICS

RoHS

### Features

- ◇ Level compensator with built-in spring, small elasticity
- ◇ Small size and light weight
- ◇ The guide rod is made of stainless steel
- ◇ Oilless wear-resistant bushing is built in the guide sleeve

### Advantages

- ◇ Avoid pollution and external mechanical force, flexible contact
- ◇ Suitable for fast handling in small space
- ◇ Resistant to environment, corrosion and abrasion
- ◇ Improve the life time of the products and reduce the noise of the products
- ◇ Ensure the accurate positioning of the workpieces



### Applications

- ◇ Suitable for electronic industry
- ◇ Suitable for handling light and small workpieces with flexible contact
- ◇ Suitable for handling workpieces with height difference
- ◇ The non-rotating level compensator is suitable for the working condition requiring accurate positioning

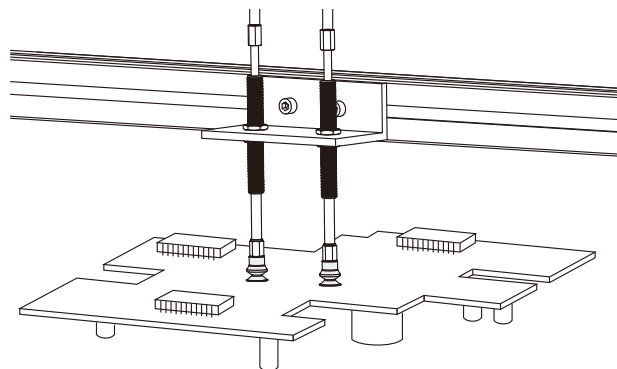

### Structure

- ◇ (1) Vacuum generator connection
- ◇ (2) Guide sleeve
- ◇ (3) Mounting nut
- ◇ (4) Guide rod
- ◇ (5) Suction cup connection

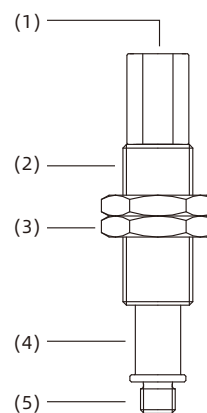

# PSPE Series

## Small and Light Level Compensator

### How to order

PSPE - I 10 L A4 M5M - M10

① Series	② Buffer style	③ Buffer stroke	④ Rotary type	⑤ Vacuum port connection	⑥ Suction cup connection	⑦ Mounting thread
PSPE	I - Built-in spring	6 25	Nil - Vertical rotating	Nil - Default	M5F - M5×0.8 female thread	M8 - M8×1
		10 30	R - Vertical non-rotating	A4 - One-touch fitting, φ4 hose	M5M - M5×0.8 male thread	M10 - M10×1
		15 40	L - Lateral rotating	A6 - One-touch fitting, φ6 hose	M8F - M8×1.25 female thread	M14 - M14×1
		20 50	B - Lateral non-rotating		M8M - M8×1.25 male thread	

### Selection-Vertical direction

Model/Connection thread M5M	RM5M	M5F	M8M	M8F
PSPE-I10M5M-M10	PSPE-I10RM5M-M10	PSPE-I10M5F-M10	PSPE-I10M8M-M14	PSPE-I10M8F-M14
PSPE-I20M5M-M10	PSPE-I20RM5M-M10	PSPE-I20M5F-M10	PSPE-I20M8M-M14	PSPE-I20M8F-M14
PSPE-I30M5M-M10	PSPE-I30RM5M-M10	PSPE-I30M5F-M10	PSPE-I30M8M-M14	PSPE-I30M8F-M14
PSPE-I40M5M-M10	PSPE-I40RM5M-M10	PSPE-I40M5F-M10	-	-
PSPE-I50M5M-M10	PSPE-I50RM5M-M10	PSPE-I50M5F-M10	PSPE-I50M8M-M14	PSPE-I50M8F-M14

### Selection-Lateral direction

Model/Connection thread LA4M5M	LA6M5M	BA4M5M	BA6M5M
PSPE-I6LA4M5M-M8	PSPE-I6LA6M5M-M8	PSPE-I6BA4M5M-M8	PSPE-I6BA6M5M-M8
PSPE-I10LA4M5M-M8	PSPE-I10LA6M5M-M8	PSPE-I10BA4M5M-M8	PSPE-I10BA6M5M-M8
PSPE-I15LA4M5M-M8	PSPE-I15LA6M5M-M8	PSPE-I15BA4M5M-M8	PSPE-I15BA6M5M-M8
PSPE-I25LA4M5M-M8	PSPE-I25LA6M5M-M8	PSPE-I25BA4M5M-M8	PSPE-I25BA6M5M-M8
PSPE-I10LA4M5M-M10	PSPE-I10LA6M5M-M10	PSPE-I10BA4M5M-M10	PSPE-I10BA6M5M-M10
PSPE-I20LA4M5M-M10	PSPE-I20LA6M5M-M10	PSPE-I20BA4M5M-M10	PSPE-I20BA6M5M-M10
PSPE-I30LA4M5M-M10	PSPE-I30LA6M5M-M10	PSPE-I30BA4M5M-M10	PSPE-I30BA6M5M-M10
PSPE-I40LA4M5M-M10	PSPE-I40LA6M5M-M10	PSPE-I40BA4M5M-M10	PSPE-I40BA6M5M-M10
PSPE-I50LA4M5M-M10	PSPE-I50LA6M5M-M10	PSPE-I50BA4M5M-M10	PSPE-I50BA6M5M-M10

◇ Note: It is suggested that the actual working compressed stroke of level compensator should not exceed 50% of its max. compressed stroke

[PSPE](#)
[PSPJ](#)
[PSPS](#)
[PSPH](#)
[PSPD](#)
[PSPF](#)
[PJS](#)
[PJT](#)
[PJF](#)
[PJB](#)
[PJE](#)
[PJH](#)

# PSPE Series

## Small and Light Level Compensator

### Dimensions(mm)

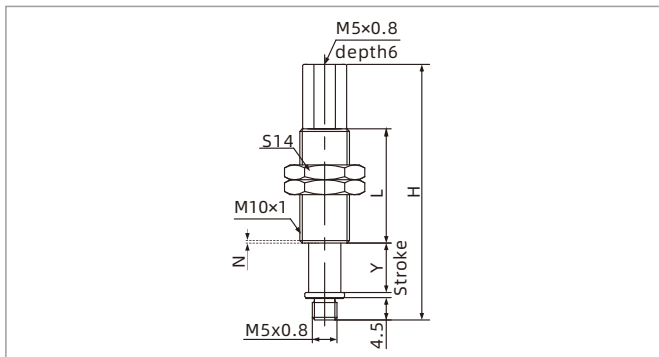

M5M-Vertical male thread connection

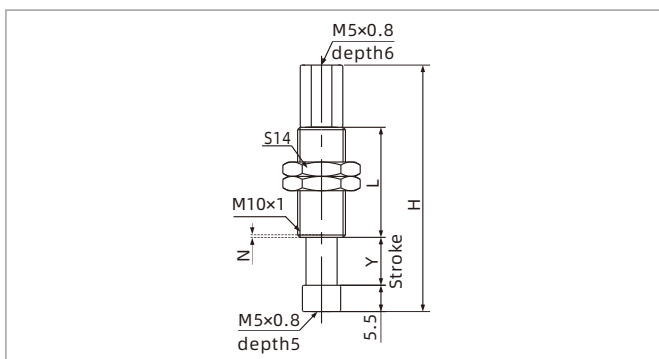

M5F-Vertical female thread connection

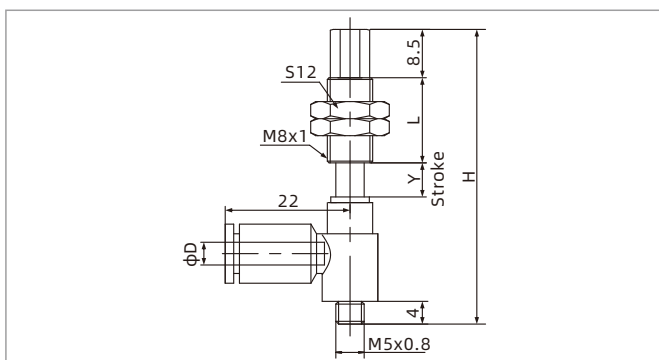

M5M-Lateral male thread connection

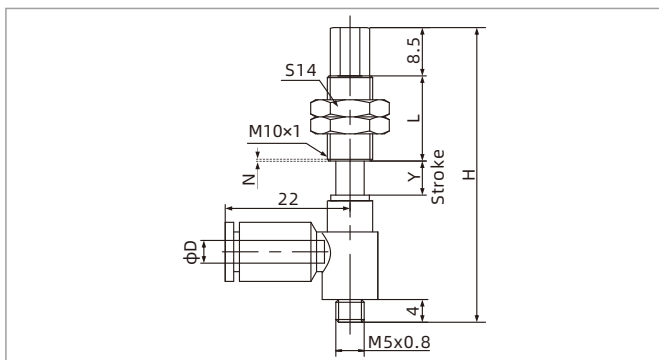

M5M-Lateral male thread connection

◇ Note: No thread at N, non-rotating N=4, rotating N=3

Model/Size	H	L	Y	Weight g	F1 N	F2 N
PSPE-I10(R)M5M-M10	51.5	23	10	22	1.0	3.0
PSPE-I20(R)M5M-M10	89.5	51	20	34	1.0	3.0
PSPE-I30(R)M5M-M10	99.5	51	30	36	1.0	3.0
PSPE-I40(R)M5M-M10	135.5	77	40	47	1.0	3.0
PSPE-I50(R)M5M-M10	145.5	77	50	50	1.0	3.0

Model/Size	H	L	Y	Weight g	F1 N	F2 N
PSPE-I10M5F-M10	51.5	23	10	23	1.0	3.0
PSPE-I20M5F-M10	89.5	51	20	36	1.0	3.0
PSPE-I30M5F-M10	99.5	51	30	38	1.0	3.0
PSPE-I40M5F-M10	135.5	77	40	49	1.0	3.0
PSPE-I50M5F-M10	145.5	77	50	51	1.0	3.0

Model/Size	H	L	Y	D	Weight g	F1 N	F2 N
PSPE-I6L(B)A4M5M-M8	52	15	6	4	19	0.8	1.2
PSPE-I6L(B)A6M5M-M8	52	15	6	6	20	0.8	1.2
PSPE-I10L(B)A4M5M-M8	84	43	10	4	26	0.8	1.2
PSPE-I10L(B)A6M5M-M8	84	43	10	6	28	0.8	1.2
PSPE-I15L(B)A4M5M-M8	89	43	15	4	27	0.8	1.2
PSPE-I15L(B)A6M5M-M8	89	43	15	6	29	0.8	1.2
PSPE-I25L(B)A4M5M-M8	99	43	25	4	29	0.8	1.2
PSPE-I25L(B)A6M5M-M8	99	43	25	6	30	0.8	1.2

Model/Size	H	L	Y	D	Weight g	F1 N	F2 N
PSPE-I10L(B)A4M5M-M10	64	23	10	4	26	1.0	3.0
PSPE-I10L(B)A6M5M-M10	64	23	10	6	28	1.0	3.0
PSPE-I20L(B)A4M5M-M10	102	51	20	4	44	1.0	3.0
PSPE-I20L(B)A6M5M-M10	102	51	20	6	46	1.0	3.0
PSPE-I30L(B)A4M5M-M10	112	51	30	4	46	1.0	3.0
PSPE-I30L(B)A6M5M-M10	112	51	30	6	48	1.0	3.0
PSPE-I40L(B)A4M5M-M10	148	77	40	4	59	1.0	3.0
PSPE-I40L(B)A6M5M-M10	148	77	40	6	62	1.0	3.0
PSPE-I50L(B)A4M5M-M10	158	77	50	4	62	1.0	3.0
PSPE-I50L(B)A6M5M-M10	158	77	50	6	65	1.0	3.0

# PSPE Series

## Small and Light Level Compensator

### Dimensions(mm)

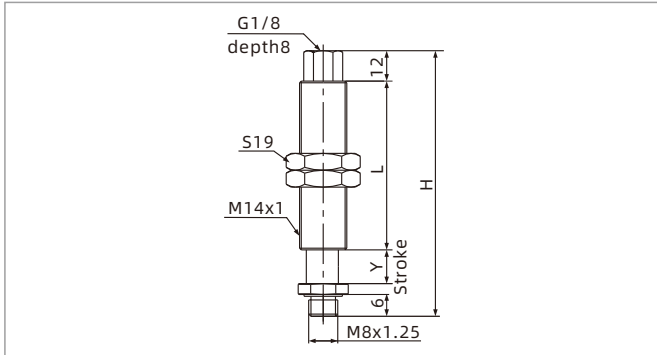

M8M-Vertical male thread connection

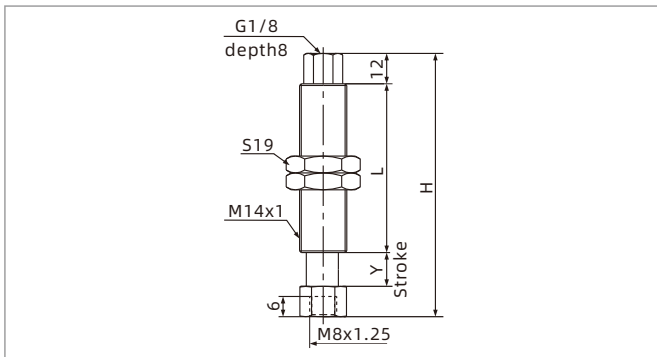

M8F-Vertical female thread connection

Model/Size	H	L	Y	Weight g	F1 N	F2 N
PSPE-I10M8M-M14	84.5	50	10	68	2.0	5.5
PSPE-I20M8M-M14	90	50	20	71	2.0	5.5
PSPE-I30M8M-M14	100	50	30	76	2.0	5.5
PSPE-I50M8M-M14	145	50	50	102	2.0	5.5

Model/Size	H	L	Y	Weight g	F1 N	F2 N
PSPE-I10M8F-M14	75	44	10	70	2.0	5.5
PSPE-I20M8F-M14	85	44	20	73	2.0	5.5
PSPE-I30M8F-M14	95	44	30	80	2.0	5.5
PSPE-I50M8F-M14	146	75	50	106	2.0	5.5

◇ Note: "F1" means spring force at 0 stroke  
 "F2" means spring force at max. stroke

PSPE

PSPL

PSPS

PSPT

PSPH

PSPD

PSPF

PJS

PJT

PJF

PJB

PJE

PJH

# PSPL Series

## Retractive Level Compensator

**AIRBEST**



ELECTRONICS



### Features

- ◇ Level compensator with built-in spring, small elasticity
- ◇ Small size and light weight
- ◇ special surface treatment for guide rod
- ◇ Guide sleeve with built-in resin bushing
- ◇ Retractive structure design

### Advantages

- ◇ Avoid pollution and external mechanical force, flexible contact
- ◇ Suitable for fast handling in small space
- ◇ Resistant to environment, corrosion and abrasion
- ◇ Reduce metal dust, special for dust-free working condition
- ◇ During the operation, the hose is static and without transverse load



### Applications

- ◇ Suitable for electronic industry
- ◇ Suitable for handling light and small workpieces with flexible contact
- ◇ Suitable for handling workpieces with height difference
- ◇ Suitable for dust-free working condition

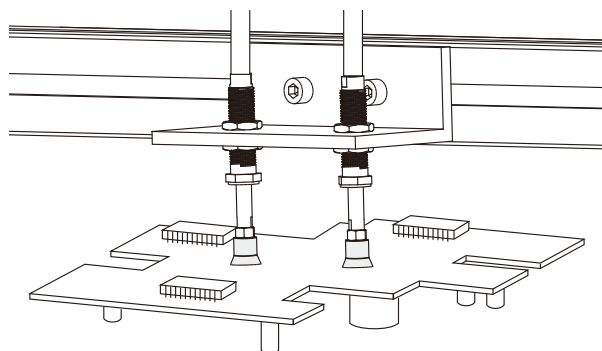

### Structure

- ◇ (1) Vacuum generator connection
- ◇ (2) Guide sleeve
- ◇ (3) Mounting nut
- ◇ (4) Guide rod
- ◇ (5) Suction cup connection

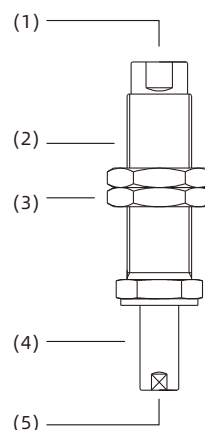

# PSPL Series

## Retractive Level Compensator

### How to order

## PSPL - I 10 R M5F - M10

①      ②      ③      ④      ⑤      ⑥

① Series	② Buffer style	③ Buffer stroke	④ Rotary type	⑤ Vacuum port connection	⑥ Mounting thread
PSPL	I - Built-in spring	3 10 15 20	Nil - Vertical rotating R - Vertical non-rotating	M5F - M5x0.8 female thread	M10 - M10x1

### Selection

Model/Buffer stroke	3	10	15	20
PSPL-I□M5F-M10	PSPL-I3M5F-M10	PSPL-I10M5F-M10	PSPL-I15M5F-M10	PSPL-I20M5F-M10
PSPL-I□RM5F-M10	-	PSPL-I10RM5F-M10	PSPL-I15RM5F-M10	PSPL-I20RM5F-M10

### Dimensions(mm)

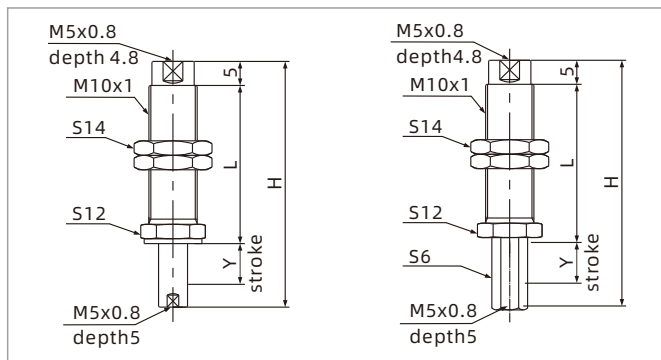

PSPL-I□M5F-M10

PSPL-I□RM5F-M10

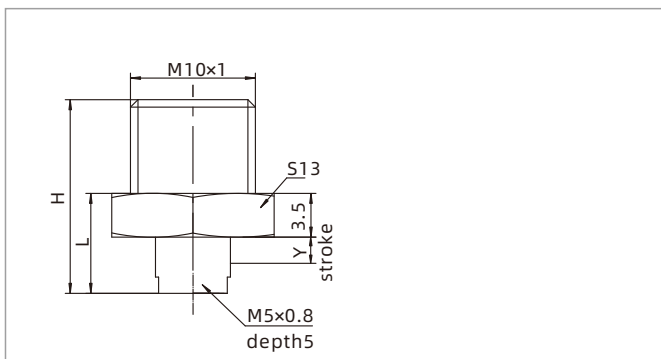

PSPL-I3M5F-M10

Model/Size	H	L	Y	F1 N	F2 N
PSPL-I10(R)M5F-M10	51	31.8	10	1.0	1.4
PSPL-I15(R)M5F-M10	61	36.8	15	1.0	1.4
PSPL-I20(R)M5F-M10	71	41.8	20	1.0	1.4

- ◇ Note: 1. "F1" means spring force at 0 stroke, "F2" means spring force at max. stroke
- 2. The locking torque of M10 nut is 2.5 ~ 3.5N.M, please work within the specified torque range

Model/Size	H	L	Y	F1 N	F2 N
PSPL-I3M5F-M10	16.5	9	3	0.7	1.0

- ◇ Note: 1. "F1" means spring force at 0 stroke, "F2" means spring force at max. stroke

# PSPS Series

## Retractive Level Compensator



ELECTRONICS



### Features

- ◇ Level compensator with built-in spring, small elasticity
- ◇ Small size and light weight
- ◇ Made of stainless steel
- ◇ Guide sleeve with built-in resin bushing
- ◇ Retractive structure design

### Advantages

- ◇ Avoid pollution and external mechanical force, flexible contact
- ◇ Suitable for fast handling in small space
- ◇ Resistant to environment, corrosion and abrasion
- ◇ Reduce metal dust, special for dust-free working condition
- ◇ During the operation, the hose is static and without transverse load



### Applications

- ◇ Suitable for electronic industry
- ◇ Suitable for handling light and small workpieces with flexible contact
- ◇ Suitable for handling workpieces with height difference
- ◇ Suitable for dust-free working condition

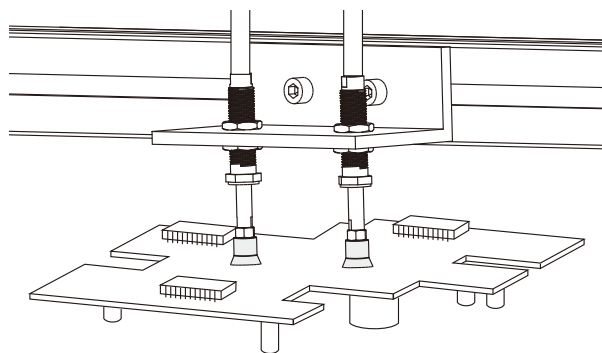

### Structure-fixed type

- ◇ (1) Vacuum generator connection
  - ◇ (2) Guide sleeve
  - ◇ (3) Mounting nut
  - ◇ (4) Guide rod
  - ◇ (5) Suction cup connection
- 

### Structure-plug in type

- ◇ (1) Nut
- ◇ (2) Combination Gasket
- ◇ (3) Clamp Plate
- ◇ (4) Nylon Gasket
- ◇ (5) Guide sleeve
- ◇ (6) Guide rod
- ◇ (7) Suction cup connection

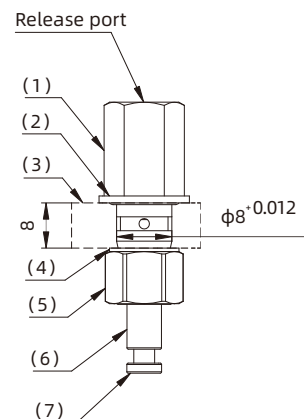

# PSPS Series

## Retractive Level Compensator

### How to order

## PSPS - I 10 M5F - M10

① ② ③ ④ ⑤

① Series	② Buffer style	③ Buffer stroke	④ Vacuum port connection	⑤ Mounting thread
PSPS	I - Built-in spring	3 6 10 15 20	M5F - M5×0.8 female thread M5M - M5×0.8 male thread D5 - φ5 suction cup fitting	M8 - M8×1 M10 - M10×1 I8 - M8×0.75 plug in connecting

### Selection

Model/Buffer stroke	3	6	10	15	20
PSPS-I□M5M-M8	-	-	PSPS-I10M5M-M8	-	-
PSPS-I□M5F-M10	-	-	PSPS-I10M5F-M10	PSPS-I15M5F-M10	PSPS-I20M5F-M10
PSPS-I□RM5F-M10	-	PSPS-I6RM5F-M10	PSPS-I10RM5F-M10	-	-
PSPS-I□D5-M8	PSPS-I3D5-M8	-	PSPS-I10D5-M8	-	-
PSPS-I□D5-I8	-	PSPS-I6D5-I8	-	-	-

◇ Note: It is suggested that the actual working compressed stroke of level compensator should not exceed 50% of its max. compressed stroke

### Dimensions(mm)

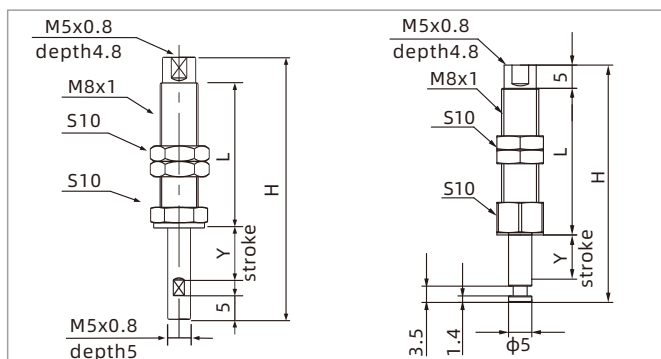

PSPS-I□M5M-M8

PSPS-I□D5-M8

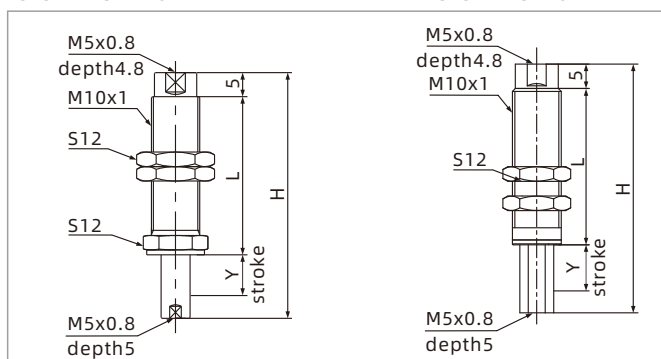

PSPS-I□M5F-M10

PSPS-I□RM5F-M10

Model/Size	H	L	Y	F1 N	F2 N
PSPS-I3D5-M8	32.5	21.5	3	0.7	0.9
PSPS-I10D5-M8	51	31.5	10	0.5	0.8
PSPS-I10M5M-M8	50	27	10	0.5	0.8

◇ Note: 1. "F1" means spring force at 0 stroke, "F2" means spring force at max. stroke  
2. The locking torque of M8 nut is 2.5 ~ 3.5N.M, please work within the specified torque range

Model/Size	H	L	Y	F1 N	F2 N
PSPS-I10M5F-M10	51	31.8	10	1.0	1.4
PSPS-I15M5F-M10	61	36.8	15	1.0	1.4
PSPS-I20M5F-M10	71	41.8	20	1.0	1.4
PSPS-I6RM5F-M10	43	28	6	0.9	1.2
PSPS-I10RM5F-M10	51	32	10	0.9	1.2

◇ Note: 1. "F1" means spring force at 0 stroke, "F2" means spring force at max. stroke  
2. The locking torque of M10 nut is 2.5 ~ 3.5N.M, please work within the specified torque range

PSPE

PSPL

PSPS

PSPT

PSPH

PSPD

PSPF

PJS

PJT

PJF

PJB

PJE

PJH

# PSPS Series

## Retractive Level Compensator

### Dimensions(mm)

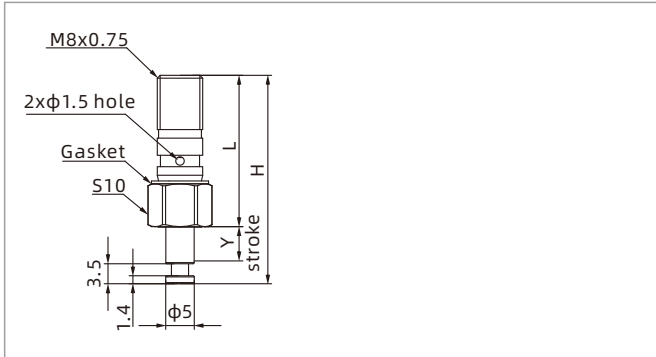

PSPS-I6D5-I8

Model/Size	H	L	Y	F1 N	F2 N
PSPS-I6D5-I8	36.5	26.5	6	0.7	0.9

- ◇ Note: 1. "F1" means spring force at 0 stroke, "F2" means spring force at max. stroke
2. The locking torque of M8 nut is 1.5 ~ 2N.m, please work within the specified torque range
3. The plug in type level compensator may experience a pressure drop ranging from 0 to 1 kPa due to varying operating conditions and usage environments
4. The nut may loosen under different usage conditions and environments, please check and maintain it regularly
5. When using the plug in type level compensator, do not block the hole at the top of the nut

# PSPT Series

## Universal Level Compensator



UNIVERSAL



### Features

- ◇ Oilless, wear-resistant bushing is built in the guide sleeve
- ◇ Built-in buffer spring and external buffer spring
- ◇ Various buffer stroke specifications are available
- ◇ Light duty and heavy duty can be selected

### Advantages

- ◇ Improve the lifetime of the products and reduce the noise of the products
- ◇ Flexible contact with fragile workpieces, compensate the height difference of workpieces
- ◇ Suitable for various working conditions



### Applications

- ◇ Suitable for handling workpieces with height difference
- ◇ Handle parts sensitive to pressure with flexible contact
- ◇ All kinds of connection specifications, universal type, suitable for various industries

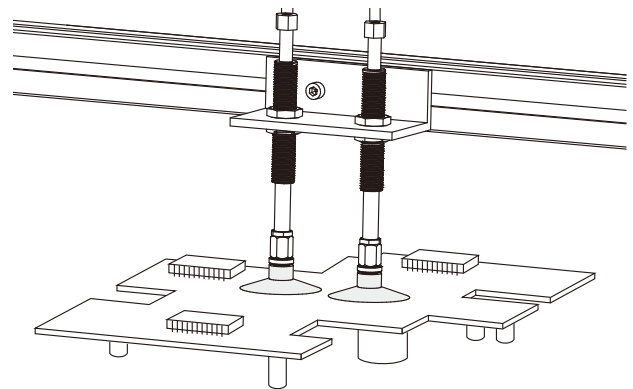

### Structure

- ◇ (1) Vacuum generator connection
- ◇ (2) Guide sleeve
- ◇ (3) Mounting nut
- ◇ (4) Spring
- ◇ (5) Suction cup connection

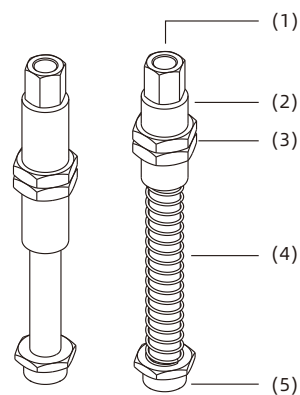

Mounting Parts

PSPE

PSPL

PSPS

**PSPT**

PSPH

PSPD

PSPF

PJS

PJT

PJF

PJB

PJE

PJH

# PSPT Series

## Universal Level Compensator

### How to order

PSPT - ① I ② 10 ③ LM5 ④ G1M - M16 - H ⑦

① Series	② Buffer type	③ Buffer stroke	④ Rotary type	⑤ Suction cup connection	⑥ Mounting thread	⑦ Heavy load
PSPT	I - Built-in spring	10 60	Nil - Vertical rotating	G1F - G1/8 female thread	M16 - M16×1	Nil - Standard
	E - External spring	20 75	R - Vertical non-rotating	G2F - G1/4 female thread	M18 - M18×1	H - Heavy load
		30 90	LM5 - Lateral rotating	G1M - G1/8 male thread		
		50 110		G2M - G1/4 male thread		
			G3M - G3/8 male thread			

### Selection

Model/Connection thread G1M	LM5G1M	G1F	G2F	
PSPT-I10G1M-M16	PSPT-I10LM5G1M-M16	PSPT-I10G1F-M16	PSPT-I10G2F-M18	PSPT-I10G2F-M18-H
PSPT-I20G1M-M16	PSPT-I20LM5G1M-M16	PSPT-I20G1F-M16	PSPT-I20G2F-M18	PSPT-I20G2F-M18-H
PSPT-I30G1M-M16	PSPT-I30LM5G1M-M16	PSPT-I30G1F-M16	PSPT-I30G2F-M18	PSPT-I30G2F-M18-H
PSPT-I50G1M-M16	PSPT-I50LM5G1M-M16	PSPT-I50G1F-M16	PSPT-I50G2F-M18	PSPT-I50G2F-M18-H

Model/Connection thread G2M			RG2M	RG3M
PSPT-I10G2M-M18	PSPT-E60G2M-M18	PSPT-I10G2M-M18-H	PSPT-I10RG2M-M18	PSPT-I10RG3M-M18
PSPT-I20G2M-M18	PSPT-E75G2M-M18	PSPT-I20G2M-M18-H	PSPT-I20RG2M-M18	PSPT-I20RG3M-M18
PSPT-I30G2M-M18	PSPT-E90G2M-M18	PSPT-I30G2M-M18-H	PSPT-I30RG2M-M18	PSPT-I30RG3M-M18
PSPT-I50G2M-M18	PSPT-E110G2M-M18	PSPT-I50G2M-M18-H	PSPT-I50RG2M-M18	PSPT-I50RG3M-M18

Model/Connection thread G3M		
PSPT-I10G3M-M18	PSPT-E60G3M-M18	PSPT-I10G3M-M18-H
PSPT-I20G3M-M18	PSPT-E75G3M-M18	PSPT-I20G3M-M18-H
PSPT-I30G3M-M18	PSPT-E90G3M-M18	PSPT-I30G3M-M18-H
PSPT-I50G3M-M18	PSPT-E110G3M-M18	PSPT-I50G3M-M18-H

◇ Note: It is suggested that the actual working compressed stroke of level compensator should not exceed 50% of its max. compressed stroke

# PSPT Series

## Universal Level Compensator

### Dimensions(mm)

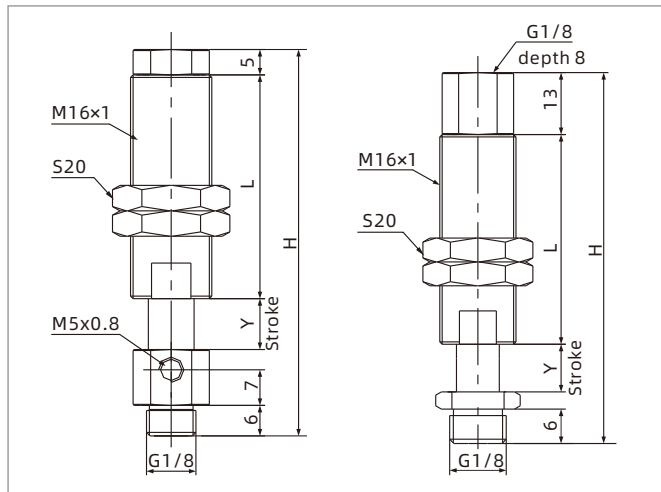

PSPT-I□LM5G1M-M16

PSPT-I□G1M-M16

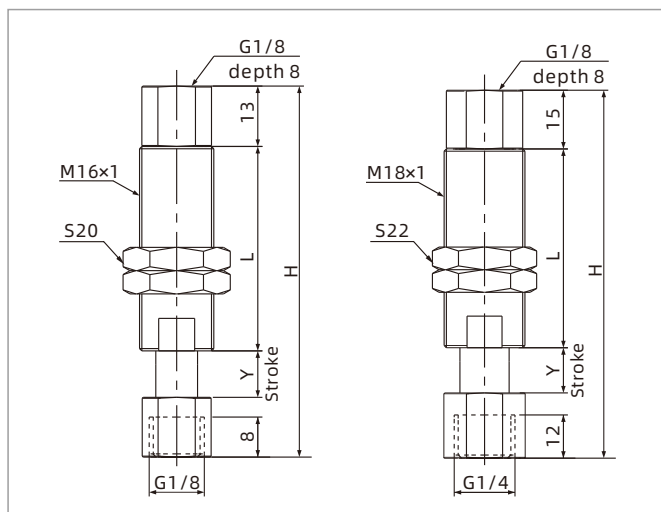

PSPT-I□G1F-M16

PSPT-I□G2F-M18

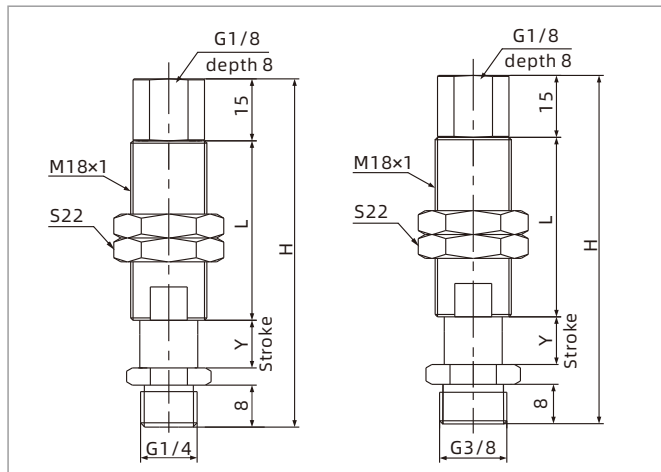

PSPT-I□G2M-M18

PSPT-I□G3M-M18

Model/Size	H	L	Y	Weight g	F1 N	F2 N
PSPT-I10LM5G1M-M16	76	44	10	71	2.0	5.5
PSPT-I20LM5G1M-M16	86	44	20	89	2.0	5.5
PSPT-I30LM5G1M-M16	96	44	30	102	2.0	5.5
PSPT-I50LM5G1M-M16	147	75	50	135	2.0	5.5
PSPT-I10G1M-M16	76	44	10	80	2.0	5.5
PSPT-I20G1M-M16	86	44	20	85	2.0	5.5
PSPT-I30G1M-M16	96	44	30	107	2.0	5.5
PSPT-I50G1M-M16	147	75	50	132	2.0	5.5

◇ Note: "F1" means spring force at 0 stroke  
"F2" means spring force at max. stroke

Model/Size	H	L	Y	Weight g	F1 N	F2 N
PSPT-I10G1F-M16	80	44	10	85	2.0	5.5
PSPT-I20G1F-M16	90	44	20	90	2.0	5.5
PSPT-I30G1F-M16	100	44	30	108	2.0	5.5
PSPT-I50G1F-M16	151	75	50	135	2.0	5.5
PSPT-I10G2F-M18	70.5	28	10	93	4.0	7.0
PSPT-I20G2F-M18	90.5	38	20	108	4.0	7.0
PSPT-I30G2F-M18	110.5	48	30	121	4.0	7.0
PSPT-I50G2F-M18	150.5	68	50	151	4.0	7.0
PSPT-I10G2F-M18-H	70.5	28	10	93	9.0	27.0
PSPT-I20G2F-M18-H	90.5	38	20	108	9.0	27.0
PSPT-I30G2F-M18-H	110.5	48	30	121	9.0	27.0
PSPT-I50G2F-M18-H	150.5	68	50	151	9.0	27.0

Model/Size	H	L	Y	Weight g	F1 N	F2 N
PSPT-I10G2M-M18	65	28	10	103	4.0	7.0
PSPT-I20G2M-M18	85	38	20	117	4.0	7.0
PSPT-I30G2M-M18	105	48	30	135	4.0	7.0
PSPT-I50G2M-M18	145	68	50	169	4.0	7.0
PSPT-I10G3M-M18	65	28	10	105	4.0	7.0
PSPT-I20G3M-M18	85	38	20	123	4.0	7.0
PSPT-I30G3M-M18	105	48	30	142	4.0	7.0
PSPT-I50G3M-M18	145	68	50	177	4.0	7.0

Mounting Parts

- PSPE
- PSPL
- PSPS
- PSPT**
- PSPH
- PSPD
- PSPF
- PJS
- PJT
- PJF
- PJB
- PJE
- PJH

# PSPT Series

## Universal Level Compensator

### Dimensions(mm)

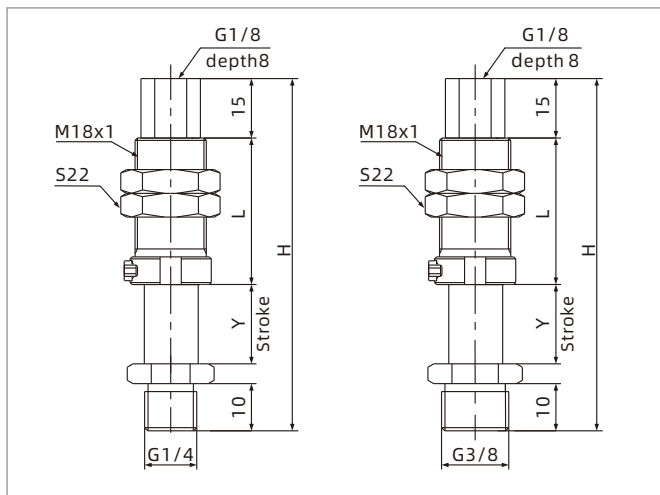

PSPT-I□RG2M-M18

PSPT-I□RG3M-M18

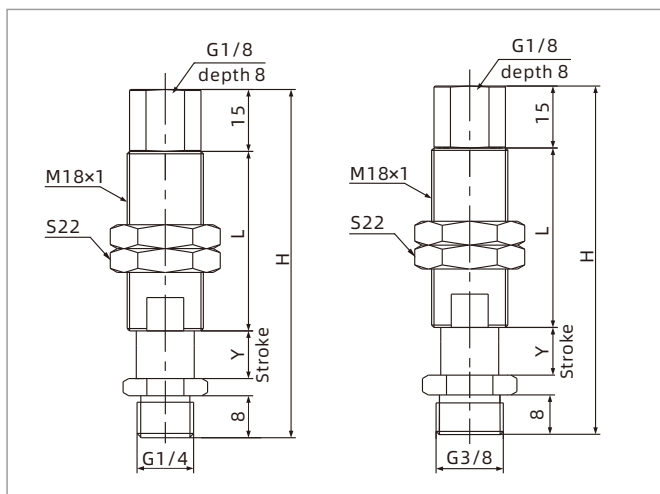

PSPT-I□G2M-M18-H

PSPT-I□G3M-M18-H

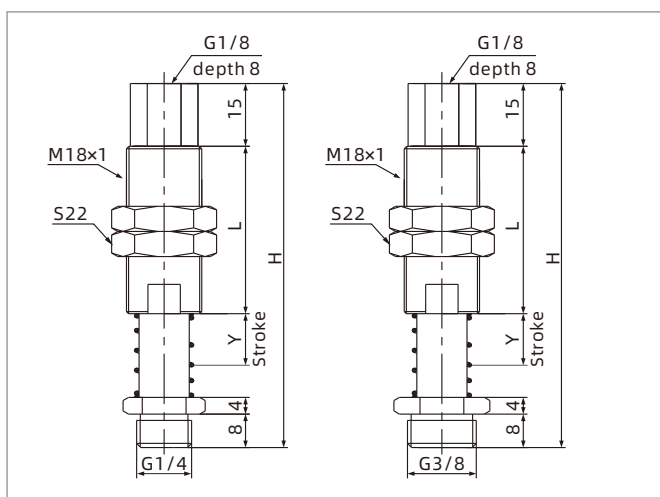

PSPT-E□G2M-M18

PSPT-E□G3M-M18

Model/Size	H	L	Y	Weight g	F1 N	F2 N
PSPT-I10RG2M-M18	70	30	10	103	4.0	7.0
PSPT-I20RG2M-M18	90	40	20	117	4.0	7.0
PSPT-I30RG2M-M18	110	50	30	135	4.0	7.0
PSPT-I50RG2M-M18	150	70	50	169	4.0	7.0
PSPT-I10RG3M-M18	70	30	10	105	4.0	7.0
PSPT-I20RG3M-M18	90	40	20	123	4.0	7.0
PSPT-I30RG3M-M18	110	50	30	142	4.0	7.0
PSPT-I50RG3M-M18	150	70	50	177	4.0	7.0

◇ Note: "F1" means spring force at 0 stroke  
"F2" means spring force at max. stroke

Model/Size	H	L	Y	Weight g	F1 N	F2 N
PSPT-I10G2M-M18-H	65	28	10	103	9.0	27.0
PSPT-I20G2M-M18-H	85	38	20	117	9.0	27.0
PSPT-I30G2M-M18-H	105	48	30	135	9.0	27.0
PSPT-I50G2M-M18-H	145	68	50	169	9.0	27.0
PSPT-I10G3M-M18-H	65	28	10	105	9.0	27.0
PSPT-I20G3M-M18-H	85	38	20	123	9.0	27.0
PSPT-I30G3M-M18-H	105	48	30	142	9.0	27.0
PSPT-I50G3M-M18-H	145	68	50	177	9.0	27.0

Model/Size	H	L	Y	Weight g	F1 N	F2 N
PSPT-E60G2M-M18	150	40	60	171	4.5	17.0
PSPT-E75G2M-M18	170	40	75	185	4.5	17.0
PSPT-E90G2M-M18	185	40	90	196	4.5	17.0
PSPT-E110G2M-M18	205	40	110	216	4.5	17.0
PSPT-E60G3M-M18	150	40	60	176	4.5	17.0
PSPT-E75G3M-M18	170	40	75	192	4.5	17.0
PSPT-E90G3M-M18	185	40	90	205	4.5	17.0
PSPT-E110G3M-M18	205	40	110	221	4.5	17.0

◇ Note: "F1" means spring force at 0 stroke,  
"F2" means spring force at max. stroke

# PSPH Series

## Heavy-duty Level Compensator



UNIVERSAL



HEAVY LOAD



### Features

- ◇ Oilless, wear-resistant bushing is built in the guide sleeve
- ◇ Heavy duty external buffer spring
- ◇ Non-rotating type can be selected
- ◇ Various buffer stroke specifications are available
- ◇ Suitable for heavy duty working condition

### Advantages

- ◇ Reduce product wear, improve the lifetime of the products and reduce the noise
- ◇ Suitable for the workpieces with uneven surface and working conditions which need height compensation
- ◇ Suitable for precise positioning of oval suction cup
- ◇ Suitable for various working conditions



### Applications

- ◇ Suitable for handling workpieces with height difference
- ◇ Suitable for working condition which needs shock absorption when handling objects
- ◇ Suitable for working condition that is with short working period and fast handling
- ◇ Non-rotating level compensator is suitable for oval suction cup
- ◇ Especially suitable for handling in automotive industry

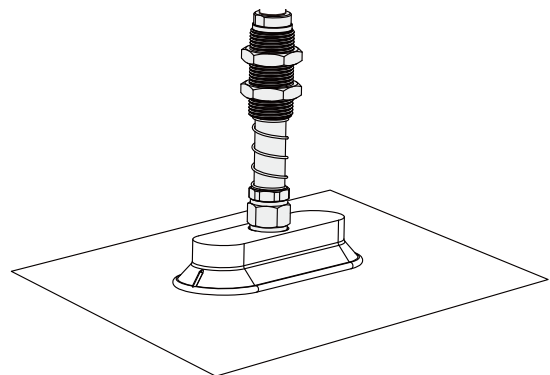

### Structure

- ◇ (1) Vacuum generator connection
- ◇ (2) Guide sleeve
- ◇ (3) Mounting nut
- ◇ (4) Guide rod
- ◇ (5) Suction cup connection

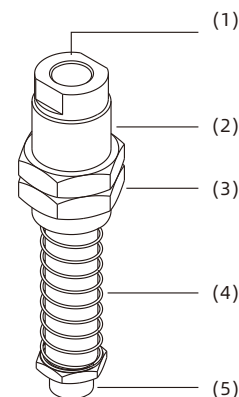

Mounting Parts

PSPE

PSPL

PSPS

PSPT

**PSPH**

PSPD

PSPF

PJS

PJT

PJF

PJB

PJE

PJH

# PSPH Series

## Heavy-duty Level Compensator

### How to order

PSPH - E 25 R G3M - M30  
 ①            ②    ③    ④    ⑤            ⑥

① Series	② Buffer type	③ Buffer stroke	④ Rotary type	⑤ Suction cup connection	⑥ Mounting thread
PSPH	E - External spring	25	Nil - Vertical rotating	G2M - G1/4 male thread	M20 - M20×1.5
		50	R - Vertical non-rotating	G3M - G3/8 male thread	M30 - M30×1.5
		75		G4M - G1/2 male thread	
		90			

### Selection

Model/Connection thread G2M	RG2M	G3M	RG3M	G4M	RG4M
PSPH-E25G2M-M20	PSPH-E25RG2M-M20	PSPH-E25G3M-M30	PSPH-E25RG3M-M30	PSPH-E25G4M-M30	PSPH-E25RG4M-M30
PSPH-E50G2M-M20	PSPH-E50RG2M-M20	PSPH-E50G3M-M30	PSPH-E50RG3M-M30	PSPH-E50G4M-M30	PSPH-E50RG4M-M30
PSPH-E75G2M-M20	PSPH-E75RG2M-M20	PSPH-E75G3M-M30	PSPH-E75RG3M-M30	PSPH-E75G4M-M30	PSPH-E75RG4M-M30
PSPH-E90G2M-M20	PSPH-E90RG2M-M20	PSPH-E90G3M-M30	PSPH-E90RG3M-M30	PSPH-E90G4M-M30	PSPH-E90RG4M-M30

### Technical parameters

Model	Pretightening force(1) N	Elastic force(2) N	Vertical load(3) N	Working temperature °C	Weight g
PSPH-E25(R)G2M-M20	7.5	15.8	2,400	0~80	148
PSPH-E50(R)G2M-M20	14.4	20	2,400	0~80	174
PSPH-E75(R)G2M-M20	6	16	2,400	0~80	198
PSPH-E90(R)G2M-M20	6	15.7	1,500	0~80	210
PSPH-E25(R)G3M-M30	19.4	73	4,800	0~80	408
PSPH-E50(R)G3M-M30	24.7	78.5	4,800	0~80	483
PSPH-E75(R)G3M-M30	39	79.6	4,800	0~80	561
PSPH-E90(R)G3M-M30	26.4	74.5	4,800	0~80	580
PSPH-E25(R)G4M-M30	19.4	73	4,800	0~80	408
PSPH-E50(R)G4M-M30	24.7	78.5	4,800	0~80	483
PSPH-E75(R)G4M-M30	39	79.6	4,800	0~80	561
PSPH-E90(R)G4M-M30	26.4	74.5	4,800	0~80	580

- ◇ Note: 1. Pretightening force is spring elastic force when spring is compressed in nature state  
 2. Elastic force is spring elastic force when level compensator is compressed in 50% stroke, it is suggested that the actual working compressed stroke of level compensator should not exceed 50% of its max. compressed stroke  
 3. Vertical load refers to the max. vertical tension that the level compensator can bear in static state  
 4. When the level compensator is installed horizontally, the workpiece will produce gravity perpendicular to the direction of the level compensator, If the gravity is larger than the horizontal load range, the spring may get stuck

# PSPH Series

## Heavy-duty Level Compensator

### Dimensions(mm)

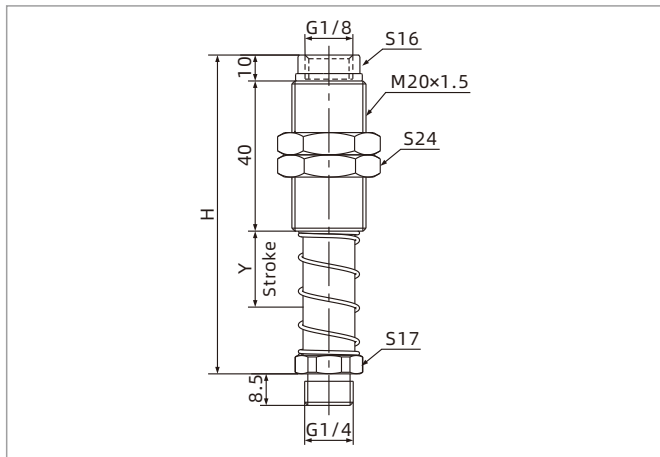

PSPH-E□(R)G2M-M20

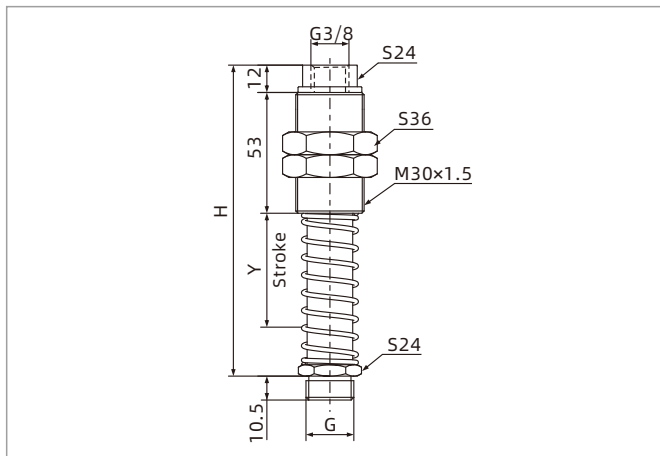

PSPH-E□(R)G3M-M30      PSPH-E□(R)G4M-M30

Model/Size	H	Y
PSPH-E25(R)G2M-M20	86	25
PSPH-E50(R)G2M-M20	114.5	50
PSPH-E75(R)G2M-M20	145	75
PSPH-E90(R)G2M-M20	160	90

Model/Size	H	G	Y
PSPH-E25(R)G3M-M30	105.5	G3/8	25
PSPH-E50(R)G3M-M30	135.5	G3/8	50
PSPH-E75(R)G3M-M30	176.5	G3/8	75
PSPH-E90(R)G3M-M30	188.5	G3/8	90
PSPH-E25(R)G4M-M30	105.5	G1/2	25
PSPH-E50(R)G4M-M30	135.5	G1/2	50
PSPH-E75(R)G4M-M30	176.5	G1/2	75
PSPH-E90(R)G4M-M30	188.5	G1/2	90

Mounting Parts

PSPE
PSPL
PSPS
PSPT
<b>PSPH</b>
PSPD
PSPF
PJS
PJT
PJF
PJB
PJE
PJH

# PSPD Series

## Double Springs Heavy-duty Level Compensator



UNIVERSAL



HEAVY LOAD



### Features

- ◇ Oilless, wear-resistant bushing is built in the guide sleeve
- ◇ With double buffer springs
- ◇ Non-rotating type can be selected
- ◇ Various buffer stroke specifications are available

### Advantages

- ◇ Reduce product wear, improve the lifetime of the products and reduce the noise
- ◇ Flexible contact with fragile workpieces, compensate the height difference of workpieces
- ◇ Suitable for precise positioning of oval suction cup
- ◇ Suitable for various working conditions

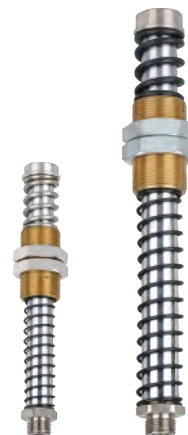

### Applications

- ◇ Suitable for handling heavy workpieces, such as steel plate
- ◇ Suitable for the working conditions that need flexible contact and shock absorption when carrying objects, such as glass
- ◇ Suitable for use in harsh environment
- ◇ Non-rotating level compensator is suitable for oval suction cup
- ◇ Double spring buffer structure can prevent the impact on the support rod end when handling the workpiece and turning it over

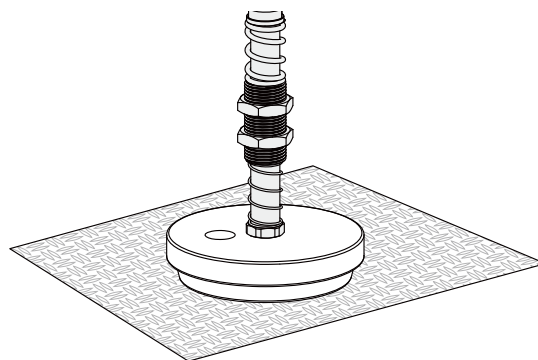

### Structure

- ◇ (1) Vacuum generator connection
- ◇ (2) Spring
- ◇ (3) Mounting nut
- ◇ (4) Guide sleeve
- ◇ (5) Spring
- ◇ (6) Suction cup connection

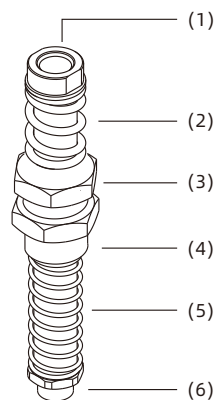

# PSPD Series

## Double Springs Heavy-duty Level Compensator

### How to order

**PSPD - E 25 R G3M - M30**  
 ①                      ②    ③    ④    ⑤                      ⑥

① Series	② Buffer type	③ Buffer stroke	④ Rotary type	⑤ Suction cup connection	⑥ Mounting thread
PSPD	E - External spring	25	Nil - Vertical rotating	G2M - G1/4 male thread	M20 - M20×1.5
		50	R - Vertical non-rotating	G3M - G3/8 male thread	M30 - M30×1.5
		90		G4M - G1/2 male thread	

### Selection

Model/Connection thread G2M	RG2M	G3M	RG3M	G4M	RG4M
PSPD-E25G2M-M20	PSPH-E25RG2M-M20	PSPD-E25G3M-M30	PSPD-E25RG3M-M30	PSPD-E25G4M-M30	PSPD-E25RG4M-M30
PSPD-E50G2M-M20	PSPH-E50RG2M-M20	PSPD-E50G3M-M30	PSPD-E50RG3M-M30	PSPD-E50G4M-M30	PSPD-E50RG4M-M30
-	-	PSPD-E90G3M-M30	PSPD-E90RG3M-M30	PSPD-E90G4M-M30	PSPD-E90RG4M-M30

### Technical parameters

Model	Pretightening force(1) N	Elastic force(2) N	Vertical load(3) N	Working temperature °C	Weight g
PSPD-E25(R)G2M-M20	8.6	16.8	2,400	0~80	181
PSPD-E50(R)G2M-M20	14.4	21	2,400	0~80	207
PSPD-E25(R)G3M-M30	24	74.5	4,800	0~80	507
PSPD-E50(R)G3M-M30	7.5	61	4,800	0~80	600
PSPD-E90(R)G3M-M30	25.2	73.7	4,800	0~80	754
PSPD-E25(R)G4M-M30	24	74.5	4,800	0~80	515
PSPD-E50(R)G4M-M30	7.5	61	4,800	0~80	608
PSPD-E90(R)G4M-M30	25.2	73.7	4,800	0~80	762

- ◇ Note: 1. Pretightening force is spring elastic force when spring is compressed in nature state
2. Elastic force is spring elastic force when level compensator is compressed in 50% stroke, it is suggested that the actual working compressed stroke of level compensator does not exceed 50% of its max. compressed stroke
3. Vertical load refers to the max. vertical tension that the level compensator can bear in static state
4. When the level compensator is installed horizontally, the workpiece will produce gravity perpendicular to the direction of the level compensator, If the gravity is bigger than the horizontal load range, the spring may get stuck

Mounting Parts

- PSPH
- PSPS
- PSPL
- PSPS
- PSPT
- PSPH
- PSPD
- PSPF
- PJS
- PJT
- PJF
- PJB
- PJE
- PJH

# PSPD Series



## Double Springs Heavy-duty Level Compensator

### Dimensions(mm)

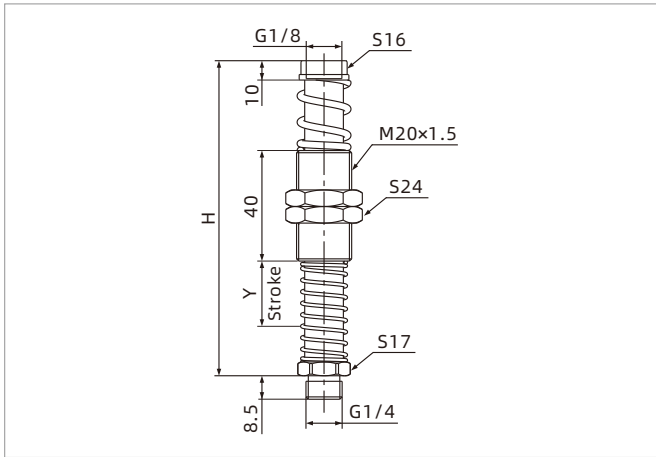

PSPD-E□(R)G2M-M20

Model/Size	H	Y
PSPD-E25(R)G2M-M20	114.5	25
PSPD-E50(R)G2M-M20	144	50

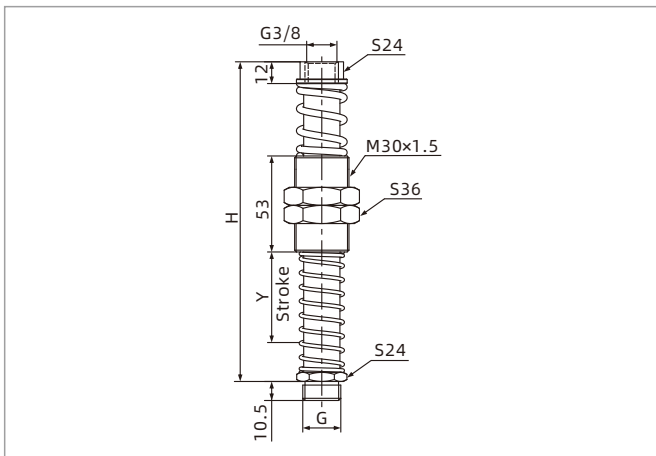

PSPD-E□(R)G3M-M30    PSPD-E□(R)G4M-M30

Model/Size	H	G	Y
PSPD-E25(R)G3M-M30	146.5	G3/8	25
PSPD-E50(R)G3M-M30	176.5	G3/8	50
PSPD-E90(R)G3M-M30	229.5	G3/8	90
PSPD-E25(R)G4M-M30	146.5	G1/2	25
PSPD-E50(R)G4M-M30	176.5	G1/2	50
PSPD-E90(R)G4M-M30	229.5	G1/2	90

# PSPF Series

## Compact Level Compensator



### Features

- ◇ Small size and light weight
- ◇ External buffer spring
- ◇ Different buffer stroke can be selected

### Advantages

- ◇ Especially suitable for electronic industry
- ◇ Flexible contact with fragile workpieces, compensate the height difference of workpieces
- ◇ Suitable for various working conditions



### Applications

- ◇ Suitable for handling workpieces with height difference
- ◇ Handle parts sensitive to poressure with flexible contact
- ◇ Suitable for electronic industry

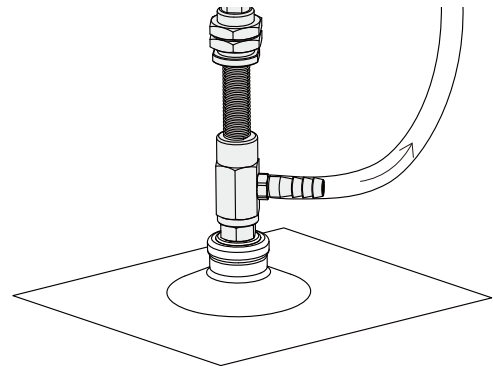

### Structure

- ◇ (1) Vacuum generator connection
- ◇ (2) Guide sleeve
- ◇ (3) Mounting nut
- ◇ (4) Spring
- ◇ (5) Suction cup connection
- ◇ (6) Vacuum generator connection

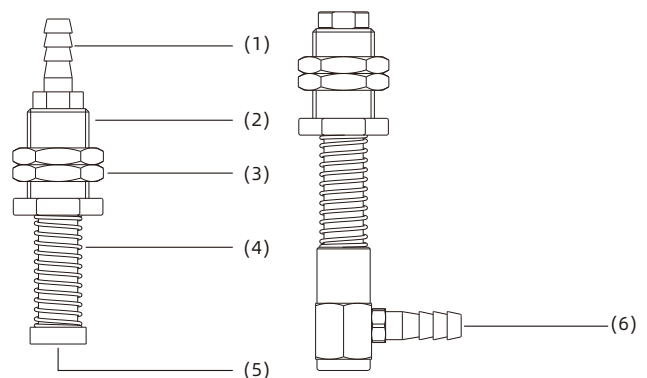

Mounting Parts

- PSPE
- PSPL
- PSPS
- PSPT
- PSPH
- PSPD
- PSPF**
- PJS
- PJT
- PJF
- PJB
- PJE
- PJH

# PSPF Series

## Compact Level Compensator

### How to order

**PSPF - E 6 LB6 M5F - M14**  
 ①            ②   ③   ④            ⑤            ⑥

① Series	② Buffer style	③ Buffer stroke	④ Rotary type
PSPF	E - External spring	4    15	B6 - Vertical rotating, pagoda fitting $\phi 6$ hose
		6    30	LB6 - Lateral rotating, pagoda fitting $\phi 6$ hose
		10	LR1 - Lateral rotating, Rc1/8 inside tapered thread

⑤ Connection thread	⑥ Mounting thread
M5F - M5×0.8 female thread	M11 - M11×1
M8F - M8×1.25 female thread	M14 - M14×1
M10M - M10×1.25 male thread	M16 - M16×1.5

### Selection

Model/Connection thread				
B6M5F	LB6M5F	B6M8F	LB6M8F	LR1M10M
PSPF-E4B6M5F-M11	PSPF-E4LB6M5F-M11	-	-	-
PSPF-E10B6M5F-M11	PSPF-E10LB6M5F-M11	-	-	-
PSPF-E6B6M5F-M14	PSPF-E6LB6M5F-M14	PSPF-E6B6M8F-M14	PSPF-E6LB6M8F-M14	-
PSPF-E15B6M5F-M14	PSPF-E15LB6M5F-M14	PSPF-E6B6M8F-M14	PSPF-E15LB6M8F-M14	-
-	-	-	-	PSPF-E10LR1M10M-M16
-	-	-	-	PSPF-E30LR1M10M-M16

◇ Note: It is suggested that the actual working compressed stroke of level compensator should not exceed 50% of its max. compressed stroke

### Dimensions(mm)

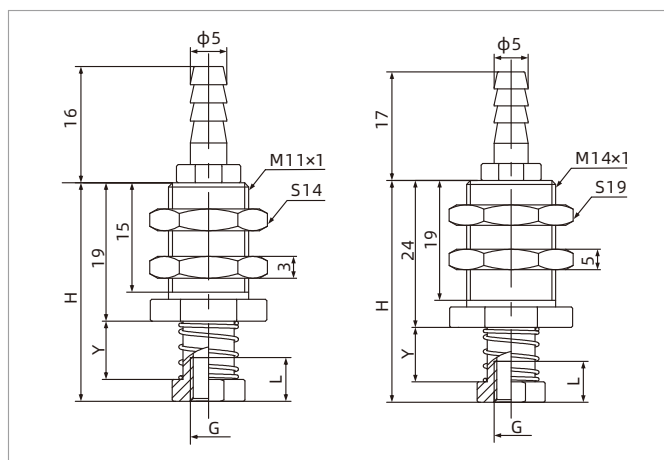

PSPF-E□B6M5F-M11

PSPF-E□B6M5F(M8F)-M14

Model/Size	H	G	L	Y	Stroke	Weight g
PSPF-E4B6M5F-M11	30	M5×0.8	6	8	4	26
PSPF-E10B6M5F-M11	42	M5×0.8	6	20	10	29.5
PSPF-E6B6M5F-M14	40	M5×0.8	6	13	6	53
PSPF-E15B6M5F-M14	57	M5×0.8	6	30	15	64.5
PSPF-E6B6M8F-M14	40	M8×1.25	8	13	6	55
PSPF-E15B6M8F-M14	57	M8×1.25	8	30	15	65



# PJS Series

## Fitting for Suction Cup

**AIRBEST**



UNIVERSAL



### Features

- ◇ Standard fitting for suction cup, easy to selection
- ◇ Split stucture design, reusable and cost saving



### How to order

**PJS - G1F - SF1 - EW**  
 ①                      ②                      ③                      ④

① Series	② Connection thread	③ Suction cup connection	Special specification
PJS	M3M - M3×0.5 male thread	M5F - M5×0.8 female thread	Nil - Default,without
	M5M - M5×0.8 male thread	G1F - G1/8 female thread	special specification
	M8M - M8×1.25 male thread	G2F - G1/4 female thread	EW - Built-in mesh filter
	G1M - G1/8 male thread	G3F - G3/8 female thread	EH - Built-in mesh filter+
	G2M - G1/4 male thread		throttle valve
	G3M - G3/8 male thread		

### Selection - SF

Model/Special specification Basic type		EW - Built-in mesh filter		EH - Built-in mesh filter + throttle valve	
PJS-G1M-SF1	PJS-G1F-SF1	PJS-G1M-SF1-EW	PJS-G1F-SF1-EW	PJS-G1M-SF1-EH	PJS-G1F-SF1-EH
PJS-G1M-SF2	PJS-G1F-SF2	PJS-G1M-SF2-EW	PJS-G1F-SF2-EW	PJS-G1M-SF2-EH	PJS-G1F-SF2-EH
PJS-G2M-SF3	PJS-G2F-SF3	PJS-G2M-SF3-EW	PJS-G2F-SF3-EW	PJS-G2M-SF3-EH	PJS-G2F-SF3-EH
PJS-G3M-SF3	PJS-G3F-SF3	PJS-G3M-SF3-EW	PJS-G3F-SF3-EW	PJS-G3M-SF3-EH	PJS-G3F-SF3-EH

### Selection - SC

Model/Connection thread M - male thread	F - female thread
PJS-M5M-SC2	PJS-M5F-SC1
PJS-M5M-SC3	PJS-M5F-SC4
-	PJS-M5F-SC5
-	PJS-M8F-SC6

### Selection - ST

Model/Connection thread M - male thread	M - male thread
PJS-M3M-ST1	PJS-M8M-ST5
PJS-M5M-ST2	PJS-M8M-ST6
PJS-M5M-ST3	PJS-M6M-ST7
PJS-M5M-ST4	PJS-G1M-ST8

# PJS Series

## Fitting for Suction Cup

### Dimensions(mm) - SF

Applicable suction cup:  
 SU20, 25, 30  
 SF20, 25, 30  
 SB17, 20  
 SBL20  
 SBP20  
 SXP20, 25, 30  
 SFP20, 30  
 SGP25, 35

PJS-G1F-SF1

Applicable suction cup:  
 SU20, 25, 30  
 SF20, 25, 30  
 SB17, 20  
 SBL20  
 SBP20  
 SXP20, 25, 30  
 SFP20, 30  
 SGP25, 35

PJS-G1M-SF1

Applicable suction cup:  
 SU40  
 SF40  
 SB30, 40  
 SBL30, 40  
 SBP30, 40  
 SXP35, 40  
 SFP40  
 SGP45

PJS-G1F-SF2

Applicable suction cup:  
 SU40  
 SF40  
 SB30, 40  
 SBL30, 40  
 SBP30, 40  
 SXP35, 40  
 SFP40  
 SGP45

PJS-G1M-SF2

Applicable suction cup:  
 SU50  
 SF50  
 SB50  
 SBL50  
 SBP50  
 SXP50  
 SGP55

PJS-G2F-SF3

Applicable suction cup:  
 SU50  
 SF50  
 SB50  
 SBL50  
 SBP50  
 SXP50  
 SGP55

PJS-G2M-SF3

Applicable suction cup:  
 SU50  
 SF50  
 SB50  
 SBL50  
 SBP50  
 SXP50  
 SGP55

PJS-G3F-SF3

Applicable suction cup:  
 SU50  
 SF50  
 SB50  
 SBL50  
 SBP50  
 SXP50  
 SGP55

PJS-G3M-SF3

Mounting Parts

PSPF

PSPH

PSPS

PSPM

PSPH

PSPD

PSPF

**PJS**

PJT

PJF

PJB

PJE

PJH

### Dimensions(mm)-ST

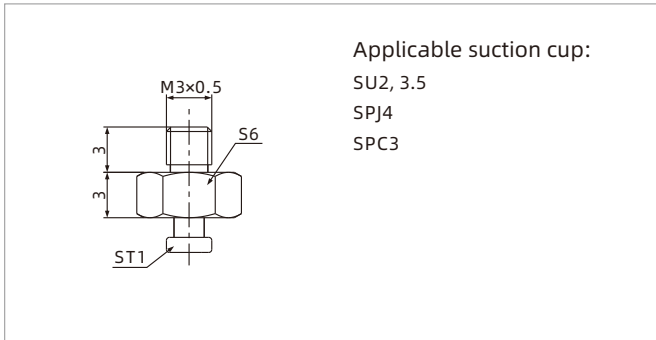

Applicable suction cup:  
 SU2, 3,5  
 SPJ4  
 SPC3

PJS-M3M-ST1

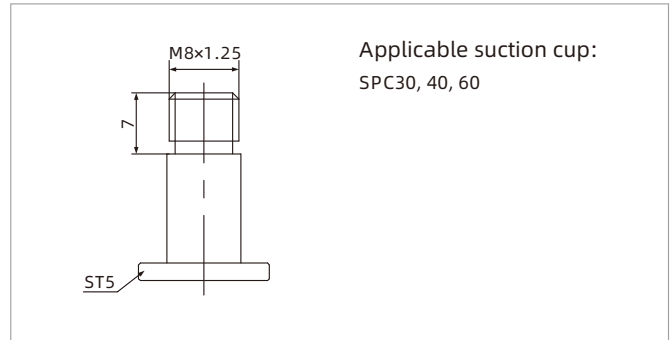

Applicable suction cup:  
 SPC30, 40, 60

PJS-M8M-ST5

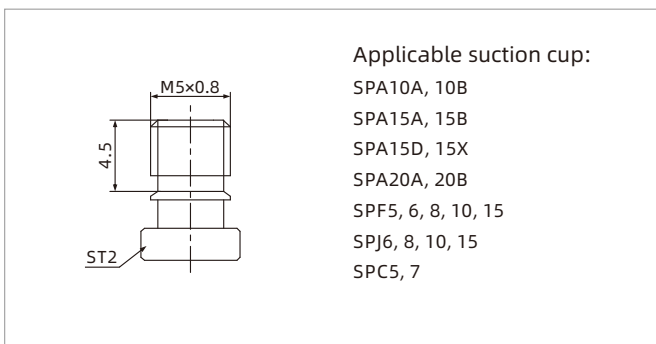

Applicable suction cup:  
 SPA10A, 10B  
 SPA15A, 15B  
 SPA15D, 15X  
 SPA20A, 20B  
 SPF5, 6, 8, 10, 15  
 SPJ6, 8, 10, 15  
 SPC5, 7

PJS-M5M-ST2

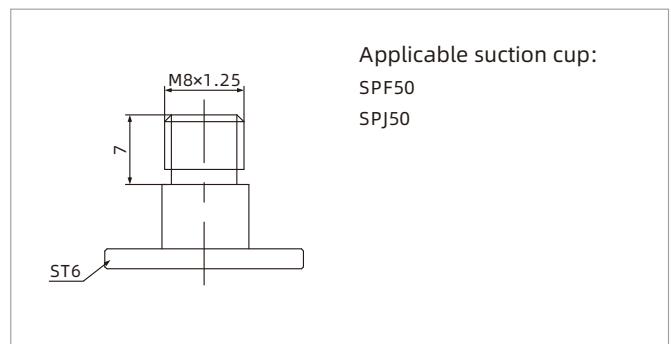

Applicable suction cup:  
 SPF50  
 SPJ50

PJS-M8M-ST6

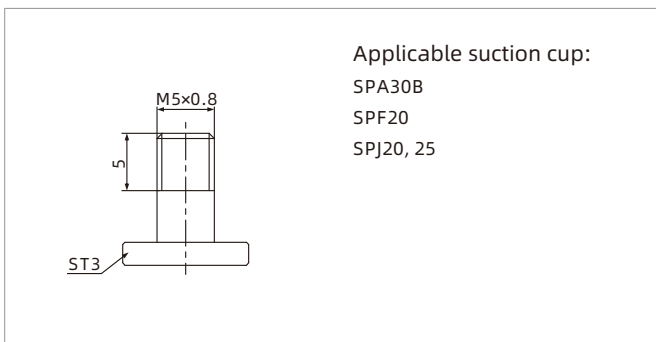

Applicable suction cup:  
 SPA30B  
 SPF20  
 SPJ20, 25

PJS-M5M-ST3

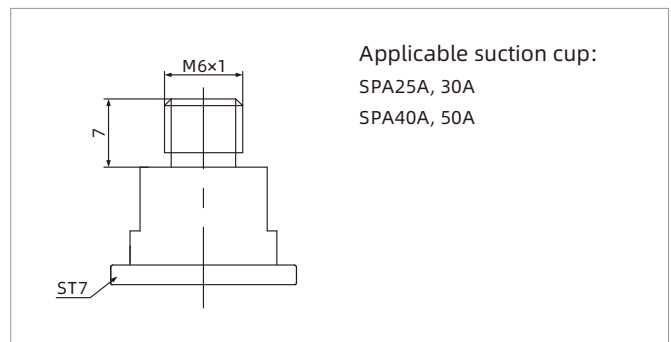

Applicable suction cup:  
 SPA25A, 30A  
 SPA40A, 50A

PJS-M6M-ST7

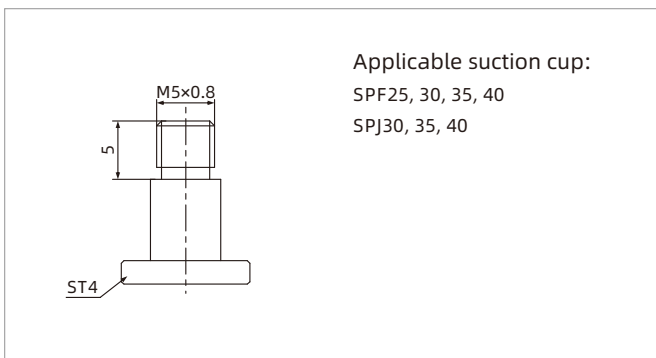

Applicable suction cup:  
 SPF25, 30, 35, 40  
 SPJ30, 35, 40

PJS-M5M-ST4

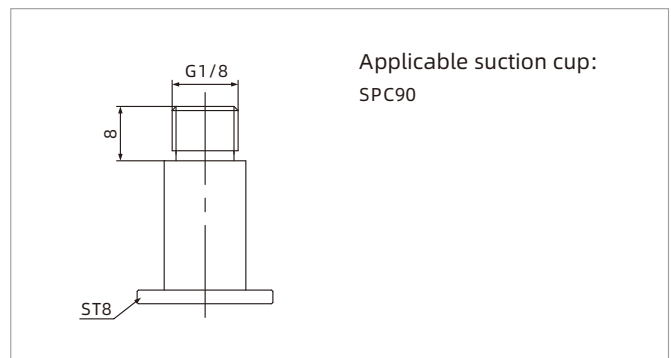

Applicable suction cup:  
 SPC90

PJS-G1M-ST8

# PJS Series

## Fitting for Suction Cup

### Dimensions(mm) - SC

Applicable suction cup:  
 SZU2, 4, 6, 8  
 SZB6, 8  
 SB6

PJS-M5F-SC1

Applicable suction cup:  
 SZU10, 13, 16  
 SZC10, 13, 16  
 SZB10, 13, 16  
 SZD10, 16

PJS-M5F-SC4

Applicable suction cup:  
 SU6, 8  
 SB5, 8

PJS-M5M-SC2

Applicable suction cup:  
 SZU20, 25, 32  
 SZC20, 25, 32  
 SZB20, 25, 32  
 SZD25

PJS-M5F-SC5

Applicable suction cup:  
 SU10, 15  
 SF15  
 SB10, 12, 15  
 SBL15  
 SBA11, 14, 16  
 SBA20, 22, 25  
 SBP10, 15  
 SPC12, 25

PJS-M5M-SC3

Applicable suction cup:  
 SZU40, 50  
 SZC40, 50  
 SZB40, 50  
 SZD40

PJS-M8F-SC6

**Mounting Parts**

PSPE
PSPL
PSPS
PSPT
PSPH
PSPD
PSPF
<b>PJS</b>
PJT
PJF
PJB
PJE
PJH

# PJT Series

## Universal Mounting Parts-Adapter

**AIRBEST**



UNIVERSAL



### Features

- ◇ Various specifications to achieve conversion between different threads
- ◇ Made of copper alloy and plated with electroless nickel



### How to order

PJT - M5M - M8F  
 ①                      ②                      ③

① Series	② Connection thread(1)	③ Connection thread(2)
PJT	M5M - M5×0.8 male thread M8M - M8×1.25 male thread G1M - G1/8 male thread G2M - G1/4 male thread G3M - G3/8 male thread M5F - M5×0.8 female thread M8F - M8×1.25 female thread G1F - G1/8 female thread G2F - G1/4 female thread G3F - G3/8 female thread	Nil - Same as connection thread(1) M5M - M5×0.8 male thread M8M - M8×1.25 male thread G1M - G1/8 male thread G2M - G1/4 male thread G3M - G3/8 male thread G4M - G1/2 male thread M5F - M5×0.8 female thread M8F - M8×1.25 female thread G1F - G1/8 female thread G2F - G1/4 female thread G3F - G3/8 female thread G4F - G1/2 female thread

### Selection - SF

Model/Type Equal diameter female-female thread	Equal diameter male-male thread	Different diameter male-male thread	Different diameter female-male thread
PJT-M5F	PJT-M5M	PJT-M5M-M8M	PJT-M5M-M8F
PJT-M8F	PJT-M8M	PJT-M8M-G1M	PJT-M8M-G1F
PJT-G1F	PJT-G1M	PJT-G1M-G2M	PJT-G1M-G2F
PJT-G2F	PJT-G2M	PJT-G2M-G3M	PJT-G2M-G3F
PJT-G3F	PJT-G3M	PJT-G3M-G4M	PJT-G3M-G4F

# PJT Series

## Universal Mounting Parts-Adapter

### Dimensions(mm)

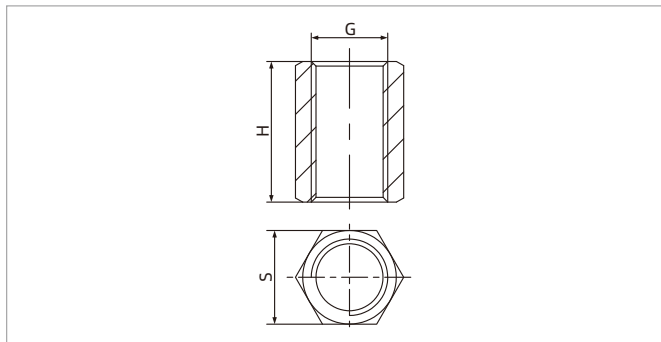

Equal diameter female-female thread

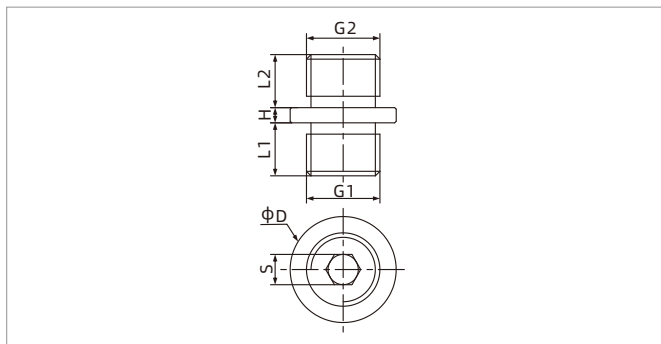

Equal diameter male-male thread

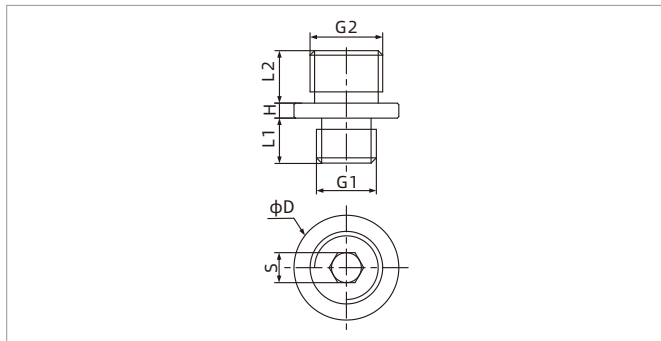

Different diameter male-male thread

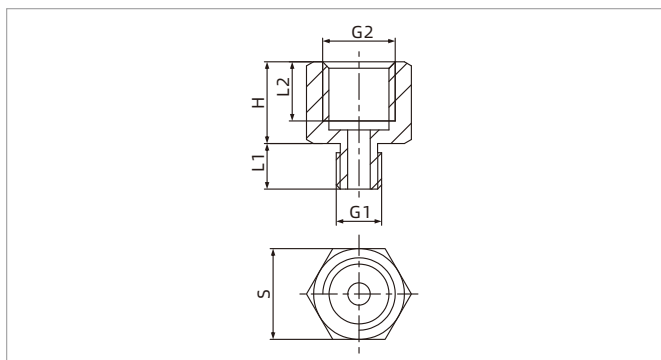

Different diameter female-male thread

Model/Size	G	H	S	Weight g
PJT-M5F	M5×0.8	11	8	4
PJT-M8F	M8×1.25	15	10	6.6
PJT-G1F	G1/8	18	12	10
PJT-G2F	G1/4	22	16	22
PJT-G3F	G3/8	24	19	27

Model/Size	G1	L1	G2	L2	H	D	S	Weight g
PJT-M5M	M5×0.8	5	M5×0.8	5	1.5	8	2.5	3
PJT-M8M	M8×1.25	7	M8×1.25	7	1.5	12	3	7
PJT-G1M	G1/8	7	G1/8	7	1.5	14	4	11.5
PJT-G2M	G1/4	9	G1/4	9	2	17	5	23
PJT-G3M	G3/8	10	G3/8	10	2	21	5	33

Model/Size	G1	L1	G2	L2	H	D	S	Weight g
PJT-M5M-M8M	M5×0.8	5	M8×1.25	6.5	1.5	12	2.5	6
PJT-M8M-G1M	M8×1.25	6.5	G1/8	7	1.5	14	3	11.5
PJT-G1M-G2M	G1/8	7	G1/4	9	1.5	17	5	15
PJT-G2M-G3M	G1/4	9	G3/8	10	2	21	5	30
PJT-G3M-G4M	G3/8	10	G1/2	12	2	24	6	37

Model/Size	G1	L1	G2	L2	H	S	Weight g
PJT-M5M-M8F	M5×0.8	5	M8×1.25	7	9	10	5
PJT-M8M-G1F	M8×1.25	7	G1/8	8	10	12	8
PJT-G1M-G2F	G1/8	7	G1/4	10	13	16	16.2
PJT-G2M-G3F	G1/4	9	G3/8	10	13	19	25
PJT-G3M-G4F	G3/8	10	G1/2	12	15	24	48

Mounting Parts

PSPE

PSPL

PSPS

PSPT

PSPH

PSPD

PSPF

PJS

**PJT**

PJF

PJB

PJE

PJH

# PJF Series

## Universal Mounting Parts-Locking Fitting

**AIRBEST**



UNIVERSAL



### Features

- ◇ Match the connection thread of suction cup, variety of connection and mounting thread are available
- ◇ Small size and simple structure, especially suitable for electronic industry



### How to order

PJF - LB6 - M4F - M5F

①                      ②                      ③                      ④

① Series	② Vacuum port connection	③ Mounting thread	④ Suction cup connection
PJF	A4 - Vertical, one-touch fittingφ4 A6 - Vertical, one-touch fittingφ6 A8 - Vertical, one-touch fittingφ8 R1 - Vertical, Rc1/8 inside tapered thread LB6 - Lateral, pagoda fittingφ6 LR1 - Lateral, Rc1/8 inside tapered threa B6 - Vertical, pagoda fittingφ6	M4F - M4×0.7 female thread M5F - M5×0.8 female thread M6F - M6×1 female thread M8F - M8×1.25 female thread M10F - M10×1.5 female thread	M8M - M8×1 male thread M10M - M10×1 male thread M12M - M12×1 male thread M14M - M14×1 male thread M16M - M16×1.5 male thread M5F - M5×0.8 female thread M8F - M8×1.25 female thread G1F - G1/8 female thread G2F - G1/4 female thread G3F - G3/8 female thread

### Selection

Model/Vacuum port connection	Lateral pagoda fitting	Vertical one-touch fitting	Vertical pagoda fitting	Vertical female thread	Lateral female thread
PJF-LB6-M4F-M5F	PJF-A4-M12M-M5F	PJF-B6-M8M-M5F	PJF-B6-M10M-M5F	PJF-R1-M16M-G2F	PJF-LR1-M10F-G2F
PJF-LB6-M6F-M5F	PJF-A6-M14M-M5F	PJF-B6-M10M-M5F	PJF-B6-M10M-M8F	PJF-R1-M16M-G3F	PJF-LR1-M10F-G3F
PJF-LB6-M6F-M8F	PJF-A6-M14M-M8F	PJF-B6-M10M-M8F	-	-	-
PJF-LB6-M8F-G1F	PJF-A6-M14M-G1F	PJF-B6-M14M-G1F	-	-	-
-	PJF-A8-M16M-G2F	-	-	-	-

### Dimensions(mm)

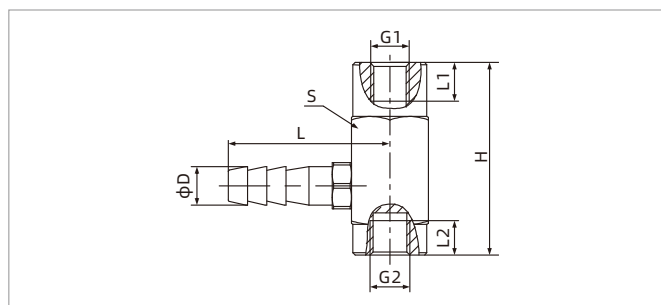

Lateral pagoda fitting

Model/size	H	G1	L1	G2	L2	S	D	L	Weight g
PJF-LB6-M4F-M5F	22	M4	6	M5	6	10	5	21	15.5
PJF-LB6-M6F-M5F	32	M6	8	M5	6	14	5	23	40
PJF-LB6-M6F-M8F	32	M6	8	M8	8	14	5	23	39
PJF-LB6-M8F-G1F	32	M8	6.5	G1/8	6	14	5	23	39

# PJF Series

## Universal Mounting Parts-Locking Fitting

### Dimensions(mm)

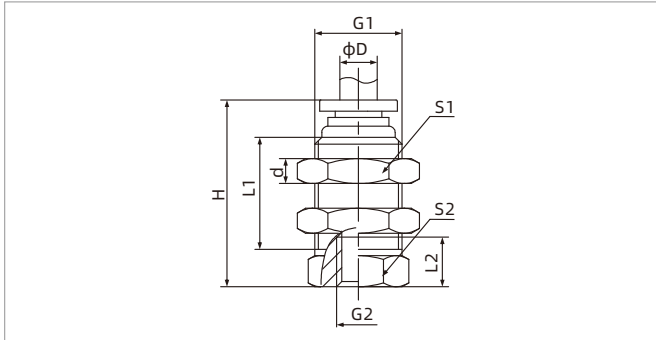

Vertical one-touch fitting

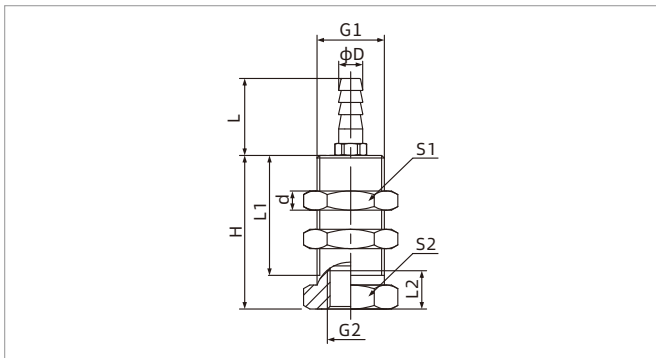

Vertical pagoda fitting

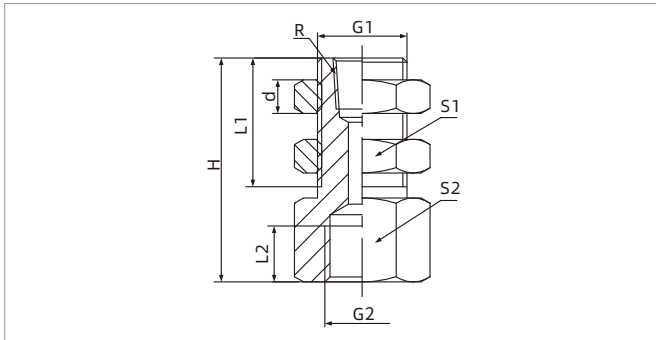

Vertical female thread

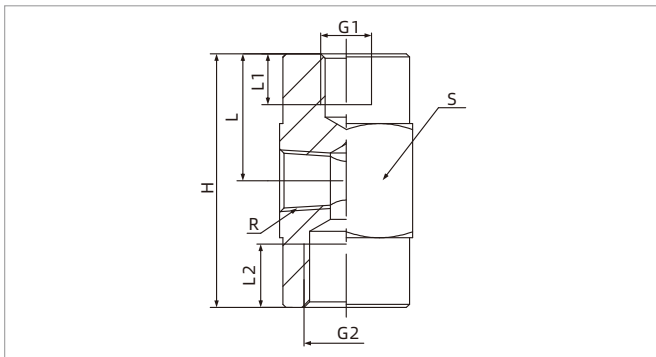

Lateral female thread

Model/Size	H	G1	L1	G2	L2	S1	S2	d	D	Weight g
PJF-A4-M12M-M5F	27.5	M12x1	17.5	M5	6	14	12	4	4	20.1
PJF-A6-M14M-M5F	29	M14x1	20	M5	6	19	14	5	6	35.3
PJF-A6-M14M-M8F	30	M14x1	18	M8	8	19	14	5	6	34.3
PJF-A6-M14M-G1F	30	M14x1	18	G1/8	8	19	14	5	6	32.3
PJF-A8-M16M-G2F	43	M16x1.5	23	G1/4	10	22	21	6	8	82.2

Model/Size	H	G1	L1	G2	L2	S1	S2	L	d	D	Weight g
PJF-B6-M8M-M5F	22	M8x1	17	M5	5	12	12	16	3	5	27
PJF-B6-M10M-M5F	32	M10x1	22	M5	6	14	14	16	3	5	30
PJF-B6-M10M-M8F	32	M10x1	22	M8	8	14	14	16	3	5	28
PJF-B6-M14M-G1F	32	M14x1	22	G1/8	8	19	17	16	5	5	33

Model/Size	H	G1	L1	G2	L2	S1	S2	d	R	Weight g
PJF-R1-M16M-G2F	40	M16x1.5	23	G1/4	10	22	21	6	Rc1/8	86.5
PJF-R1-M16M-G3F	40	M16x1.5	23	G3/8	11	22	21	6	Rc1/8	78

Model/Size	H	G1	L1	G2	L2	S	L	R	Weight g
PJF-LR1-M10F-G2F	40	M10	8	G1/4	10	21	20	Rc1/8	88.5
PJF-LR1-M10F-G3F	40	M10	8	G3/8	11	21	20	Rc1/8	79

PSPE

PSPL

PSPS

PSPT

PSPH

PSPD

PSPF

PJS

PJT

**PJF**

PJB

PJE

PJH

# PJB Series

## Universal Mounting Parts-Ball Joint



UNIVERSAL



### Features

- ◇ Flexible connection for deflection in any direction with a maximum deflection angle of 12°
- ◇ The ball and socket are equipped with sealing rings to prevent vacuum leakage during rotation
- ◇ It is made of high strength steel and has good stability
- ◇ Suitable for large suction cup to handle workpiece with inclined surface



### How to order

PJB - G4M - S  
 ①                      ②                      ③

① Series	② Suction cup connection		③ External sealing device
PJB	G1M - G1/8 male thread	G2M - G1/4 male thread	Nil - Standard type
	M10M - M10×1.25 male thread	G4M - G1/2 male thread	S - With external sealing suction cup

### Selection

Model/Suction cup connection G1M		M10M	G2M	G4M	
PJB-G1M	PJB-G1M-S	PJB-M10M	PJB-G2M	PJB-G4M	PJB-G4M-S

### Dimensions(mm)

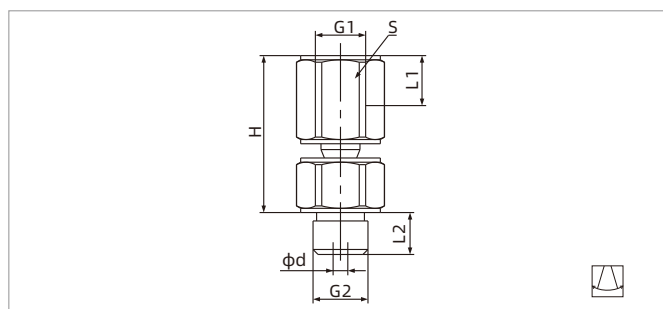

PJB-□

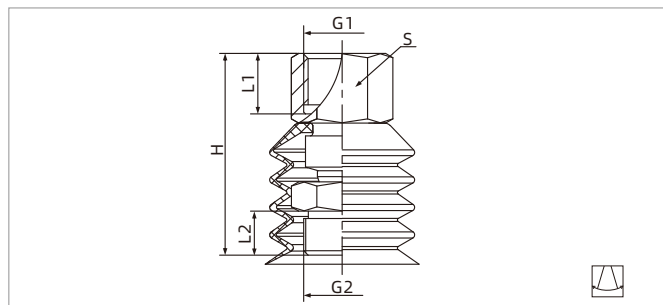

PJB-□-S

Model/Size	H	G1	L1	G2	L2	S	d	Deflection angle	Weight g
PJB-G1M	26.5	G1/8	8	G1/8	7	12	2	12°	20
PJB-M10M	37.5	G1/4	12	M10×1.25	10	19	3.5	12°	82
PJB-G2M	37.5	G1/4	12	G1/4	10	19	3.5	12°	75
PJB-G4M	40	G1/2	15	G1/2	12	24	4	12°	113

Model/Size	H	G1	L1	G2	L2	S	Deflection angle	Weight g
PJB-G1M-S	33	G1/8	8	G1/8	7	12	12°	21
PJB-G4M-S	52	G1/2	15	G1/2	12	24	12°	133

# PJE Series

## Universal mounting parts-flexible joint



UNIVERSAL



### Features

- ◇ Flexible connection for deflection in any direction with a maximum deflection angle 12°
- ◇ The rotating joints are vulcanized by high-strength metal and high-performance rubber, which guarantees strength, elasticity and sealability, and can be automatically reset
- ◇ Suitable for large suction cup to handle workpiece with inclined surface



### How to order

## PJE - G2F - G2M

①                      ②                      ③

① series	② Vacuum port connection	③ Suction cup connection
PJE	G2M - G1/4 male thread G4M - G1/2 male thread G2F - G1/4 female thread G4F - G1/2 female thread	M10M - M10×1.25 male thread G2M - G1/4 male thread G4M - G1/2 male thread

### Selection

Model/Vacuum port connection G2M	G2F	G4M	G4F
PJE-G2M-G2M	PJE-G2F-M10M   PJE-G2F-G2M	PJE-G4M-G4M	PJE-G4F-G4M

### Dimensions(mm)

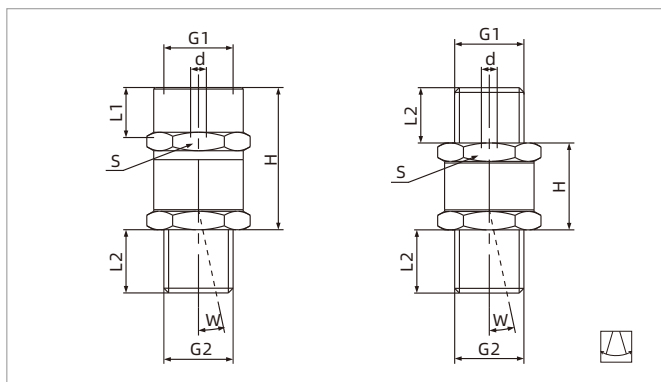

PJE-F-M

PJE-M-M

Model/Size	H	G1	L1	G2	L2	d	S	W	Weight g
PJE-G2F-M10M	27	G1/4	12	M10×1.25	8	3	17	12°	33.5
PJE-G2F-G2M	27	G1/4	12	G1/4	12	3	17	12°	39
PJE-G2M-G2M	16.5	G1/4	10.5	G1/4	12	3	17	12°	32.5
PJE-G4F-G4M	33.5	G1/2	14	G1/2	14	6	27	12°	105.5
PJE-G4M-G4M	21	G1/2	14	G1/2	14	6	27	12°	94.5

# PJH Series

## Universal Mounting Parts-Flexible Joint

**AIRBEST**



UNIVERSAL



### Features

- ◇ Ball clamp structure , which can adjust height and angle.  
It is suitable for workpiece with irregular surface
- ◇ Made of high-strength aluminum alloy and light weight



### How to order

PJH - 1 A 80  
① ② ③ ④

① Series	② Mounting Specification	③ Connection thread	④ Length of connecting rod
PJH	1 - 1×M5 Fixed screw	A - G1/4	80 - 80mm    140 - 140mm
	2 - 2×M6 Fixed screw	B - G3/8	100 - 100mm    200 - 200mm

### Selection

Model/Mounting specification 1A	1B	2A	2B
PJH-1A80	PJH-1B80	PJH-2A80	PJH-2B80
PJH-1A100	PJH-1B100	PJH-2A100	PJH-2B100
PJH-1A140	PJH-1B140	PJH-2A140	PJH-2B140
PJH-1A200	PJH-1B200	PJH-2A200	PJH-2B200

### Dimensions(mm)

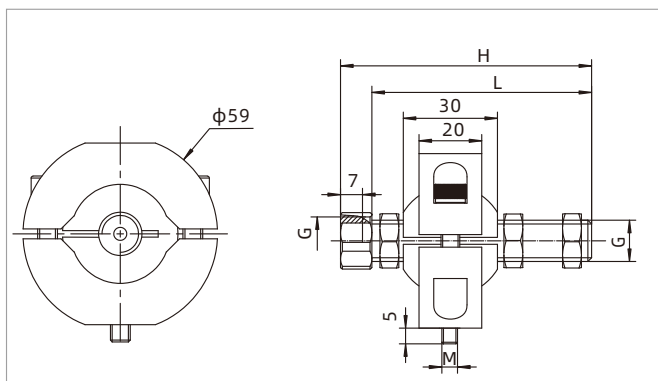

PJH-1□□

Model/Size	G	M	H	L	Setting angle	Weight g
PJH-1A80	G1/4	M5×0.8	80	70	15°	293
PJH-1A100	G1/4	M5×0.8	100	90	15°	299.5
PJH-1A140	G1/4	M5×0.8	140	130	15°	314
PJH-1A200	G1/4	M5×0.8	200	190	15°	335
PJH-1B80	G3/8	M5×0.8	80	70	15°	325
PJH-1B100	G3/8	M5×0.8	100	90	15°	331
PJH-1B140	G3/8	M5×0.8	140	130	15°	352
PJH-1B200	G3/8	M5×0.8	200	190	15°	385

# PJH Series

## Universal Mounting Parts-Flexible Joint

### Dimensions(mm)

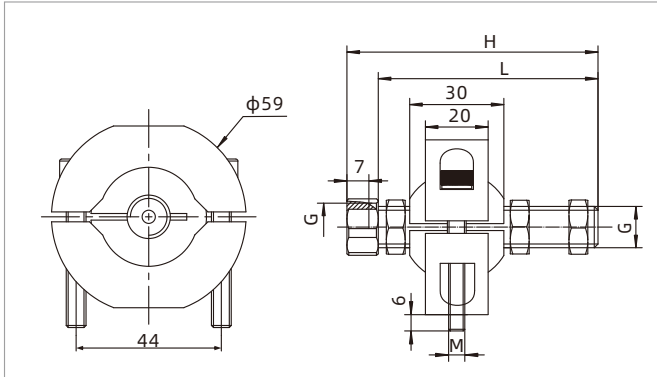

PJH-2□□

Model/Size	G	M	H	L	Setting angle	Weight g
PJH-2A80	G1/4	2-M6×1	80	70	15°	216
PJH-2A100	G1/4	2-M6×1	100	90	15°	222.5
PJH-2A140	G1/4	2-M6×1	140	130	15°	237
PJH-2A200	G1/4	2-M6×1	200	190	15°	257.5
PJH-2B80	G3/8	2-M6×1	80	70	15°	192.5
PJH-2B100	G3/8	2-M6×1	100	90	15°	203.5
PJH-2B140	G3/8	2-M6×1	140	130	15°	239.5
PJH-2B200	G3/8	2-M6×1	200	190	15°	286.5

PSPE

PSPL

PSPS

PSPT

PSPH

PSPD

PSPF

PJS

PJT

PJF

PJB

PJE

**PJH**

## **G** Vacuum Accessories

# Vacuum Accessories

## Products overview

### Vacuum Accessories

#### 441 ZFS Series

##### Universal Vacuum Filter

- ◇ Max. pressure resistance: 0.9Mpa
- ◇ Max. vacuum flow: 25NL/min



UNIVERSAL



#### 450 ZFP Series

##### Large-Flow Vacuum Filter

- ◇ Nominal flow: 32-300m<sup>3</sup>/h
- ◇ Removal efficiency: 10µm



UNIVERSAL



#### 443 ZFA Series

##### Universal Vacuum Filter

- ◇ Nominal flow: 40-370NL/min
- ◇ Removal efficiency: 5µm



UNIVERSAL



#### 452 ZVAB Series

##### Pneumatic Control Valve

- ◇ Pressure range: 1.5-8.0bar
- ◇ Control mode: Pneumatic control - NO NC



UNIVERSAL



#### 446 ZFD Series

##### Mini Type Vacuum Filter

- ◇ Nominal flow: 27-49NL/min
- ◇ Removal efficiency: 10µm



UNIVERSAL



#### 453 ZVAC Series

##### Pneumatic Control Valve

- ◇ Pressure range: 1.0-8.0bar
- ◇ Control mode: Pneumatic control - NO NC



UNIVERSAL



#### 447 ZFB Series

##### Universal Vacuum Filter

- ◇ Nominal flow: 150-510NL/min
- ◇ Removal efficiency: 10µm



UNIVERSAL



#### 454 ZVEA Series

##### Electric Control Valve

- ◇ Pressure range: 3.5-7.0bar
- ◇ Control mode: Electric Control - NC



UNIVERSAL



#### 449 ZFL Series

##### Inline Vacuum Filter

- ◇ Nominal flow: 25-220NL/min
- ◇ Removal efficiency: 20-25µm



UNIVERSAL



#### 455 ZVR Series

##### Check Valve

- ◇ Max. blow-off flow: 80-790NL/min
- ◇ Connection thread: M5-G1/2



UNIVERSAL



# Vacuum Accessories

## Products overview



### Vacuum Accessories

#### 457 ZVRM Series

##### Check Valve

- ◇ Min. action flow: 2-16NL/min
- ◇ Connection thread: M5 G1/8



UNIVERSAL



RoHS

#### 463 ZPDT Series

##### High-precision Digital Pressure Switch

- ◇ Pressure range: -100.0~100.0kPa
- ◇ Output type: 1NPN+1Analog voltage output  
1PNP+1Analog voltage output



UNIVERSAL



RoHS

#### 459 ZVCM Series

##### Non-return Valve

- ◇ Pressure range: -100~0kPa
- ◇ Connection thread: M5 G1/8



UNIVERSAL



RoHS

#### 467 ZPDE Series

##### High-precision Digital Pressure Switch

- ◇ Pressure range: -100.0~100.0kPa
- ◇ Output type: 1NPN output



UNIVERSAL



RoHS

#### 460 ZVD Series

##### Contact Inductive Valve

- ◇ Connection thread: G1/2 G1/4



UNIVERSAL



RoHS

#### 471 ZPMR Series

##### Mechanical Pressure Gauge

- ◇ Pressure range: P type 0-1MPa
- ◇ Pressure range: V type -100-0kPa



UNIVERSAL



RoHS

#### 461 ZVS Series

##### Fast Blow-off Valve

- ◇ Max. blow-off flow: 160NL/min
- ◇ Connection thread: G1/8 G1/4



UNIVERSAL



RoHS

#### 472 ZSA Series

##### Silencer

- ◇ Connection thread: G1/8 G1/4 G3/8  
G1/2 G3/4 G1"



UNIVERSAL



RoHS

# ZFS Series

## Air Filter

AIRBEST



UNIVERSAL



### Features

- ◇ Straight through structure, both ends are connected with thread, easy installation
- ◇ Small size and light weight
- ◇ Using anticorrosive material, can resist weak acid and alkali corrosion
- ◇ Can withstand up to 200°C high temperature
- ◇ Transparent housing, can directly observe the pollution degree of filter element
- ◇ Stainless steel filter element, easy to clean
- ◇ Can be used in positive or negative pressure systems



### Applications

- ◇ Suitable for positive pressure and vacuum systems with light or medium pollution levels
- ◇ Suitable for the working environment with certain corrosion resistance requirements
- ◇ Suitable for high temperature working environment

### How to Order

## ZFS 10 - G1F

① ② ③

① Series	② Filter specification	③ Connection thread
ZFS	10	G1F - G1/8 Female thread G1M - G1/8 Male thread

### Selection

Model/ Connection thread	G1F	G1M
ZFS10	ZFS10-G1F	ZFS10-G1M

### Technical parameters

Model	Rated operating pressure range Mpa	Max. pressure resistance Mpa	Max. positive pressure flow L/min	Max. vacuum flow L/min	Fluid	Hose diameter mm	Operating temperature °C	Weight g
ZFS10-G1F	-0.1~0.6	0.9	250	25	Air, inert gas, slightly corrosive gas	8	0~200	29
ZFS10-G1M	-0.1~0.6	0.9	250	25	Air, inert gas, slightly corrosive gas	8	0~200	39

Vacuum Accessories

ZFS

ZFA

ZFD

ZFB

ZFL

ZFP

ZVAB

ZVAC

ZVEA

ZVR

ZVRM

ZVCM

ZVD

ZVS

ZPDT

ZPDE

ZPMR

ZSA

# ZFS Series

## Air Filter

### Technical parameters

Spare parts	Material
End cover, filter element	316 Stainless steel
Housing	Teflon
Seal ring	Fluororubber

### Dimensions (mm)

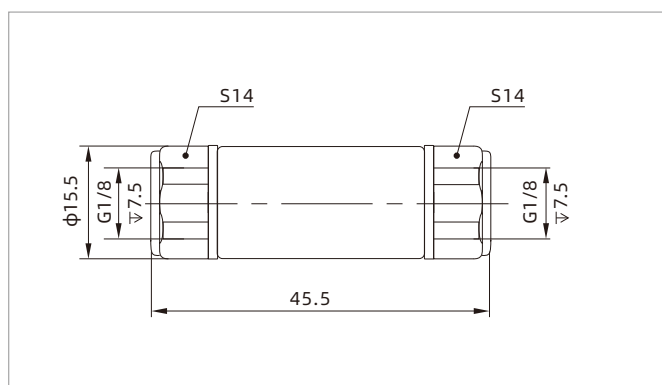

ZFS10-G1F

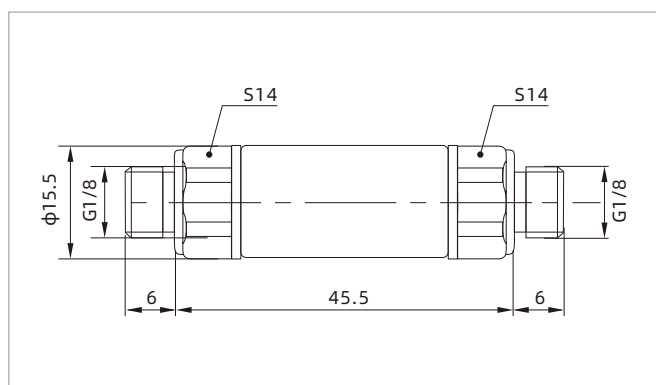

ZFS10-G1M

### Structural diagram

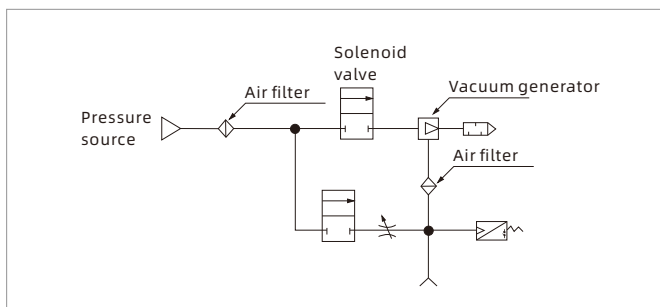

#### Cautions:

1. Please connect and use the air filter according to the diagram
  2. Please use the filter as far as possible under the rated operating pressure
  3. The filter itself and piping shall not withstand torsion, pulling, load, vibration, impact and other external forces, it may causes danger if withstanding extra external force under high positive pressure.
  4. When disassembling and cleaning the filter, please pay attention to ensure that the sealing ring is not damaged, and the tightening torque is  $3 \pm 0.3 \text{ N} \cdot \text{m}$  of the front and back covers when reassembling
- ★ When using the filter in positive pressure environment, do not connect the filter behind the solenoid valve, which will cause the filter to withstand frequent shocks if solenoid valve is long-term frequent on-off

# ZFA Series

## Universal Vacuum Filter

**AIRBEST**



UNIVERSAL

RoHS

### Features

- ◇ Straight through design, one-touch fitting, with bracket, easy to mount
- ◇ Small size and light weight
- ◇ Filter elements could be replaced
- ◇ Suitable for vacuum and positive pressure systems with light or medium pollution level



Vacuum Accessories

ZFS

ZFA

ZFD

ZFB

ZFL

ZFP

ZVAB

ZVAC

ZVEA

ZVR

ZVRM

ZVCM

ZVD

ZVS

ZPDT

ZPDE

ZPMR

ZSA

### How to order

**ZFA 5 4 B**  
 ① ② ③ ④

① Series	② Filter area	③ Hose diameter	④ Bracket
ZFA	5 - Filter area 790mm <sup>2</sup> 7 - Filter area 1,280mm <sup>2</sup>	4 - φ4 hose 6 - φ6 hose 8 - φ8 hose 10 - φ10 hose 12 - φ12 hose	B - Default, with bracket

### Selection

Model/Hose diameter 4 - φ4hose	6 - φ6hose	8 - φ8hose	10 - φ10hose	12 - φ12hose
ZFA54B	ZFA56B	-	-	-
-	ZFA76B	ZFA78B	ZFA710B	ZFA712B

### Technical parameters

Model	Hose diameter mm	Fluid	Rated operating pressure range MPa	Max. pressure resistance MPa	Positive pressure flow NL/min	Vacuum flow NL/min	Removal efficiency μm	Operating temperature °C	Weight g
ZFA54B	φ4	Air,Nitrogen	-0.1~0.8	1.0	40	10	5	0~60	14
ZFA56B	φ6	Air,Nitrogen	-0.1~0.8	1.0	130	75	5	0~60	13
ZFA76B	φ6	Air,Nitrogen	-0.1~0.8	1.0	140	80	5	0~60	24
ZFA78B	φ8	Air,Nitrogen	-0.1~0.8	1.0	280	110	5	0~60	24
ZFA710B	φ10	Air,Nitrogen	-0.1~0.8	1.0	320	120	5	0~60	30
ZFA712B	φ12	Air,Nitrogen	-0.1~0.8	1.0	370	140	5	0~60	31

◇ Note: Positive pressure flow is tested at air supply pressure 0.1Mpa

# ZFA Series

## Universal Vacuum Filter

### Max. operating pressure and temperature

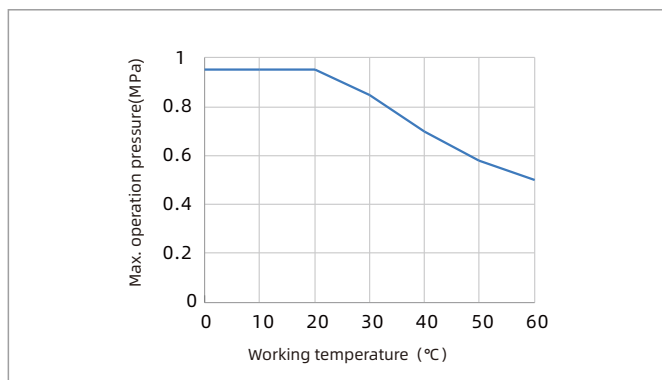

### Application diagram

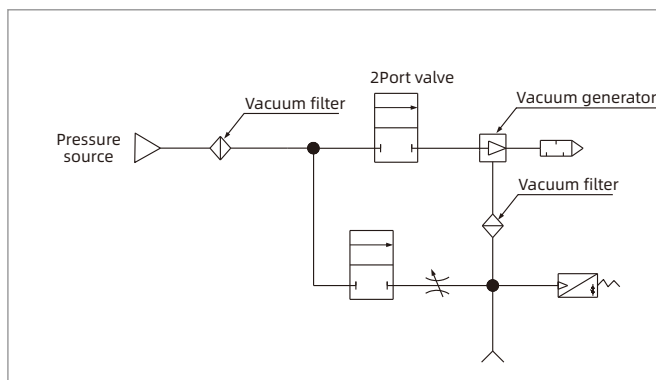

### Dimensions (mm)

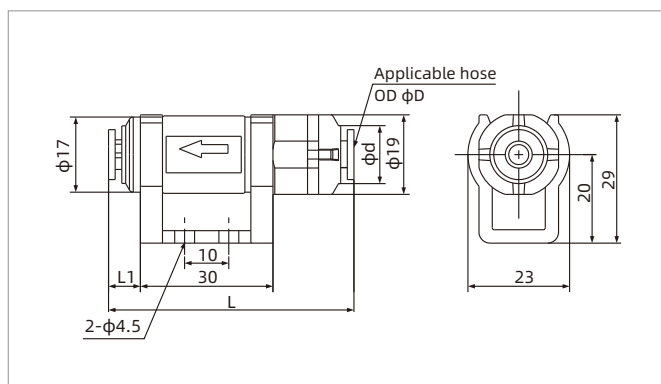

ZFA5□B

Model/Size	L	L1	D	d
ZFA54B	55.5	8	4	13
ZFA56B	55.5	8	6	13

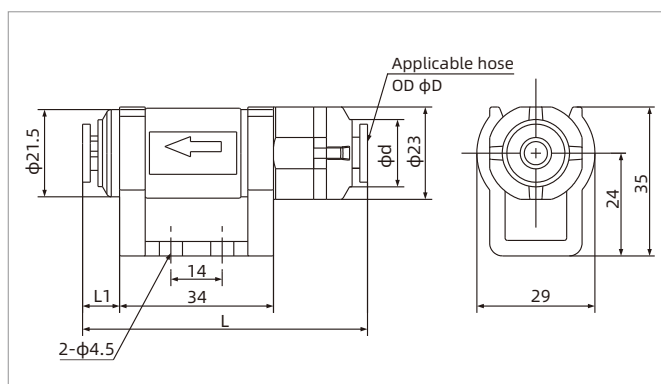

ZFA7□B

Model/Size	L	L1	D	d
ZFA76B	67	10.5	6	15.5
ZFA78B	69.5	12	8	16
ZFA710B	78.5	17	10	19.5
ZFA712B	78.5	17	12	21

# ZFA Series

## Universal Vacuum Filter



### Structural diagram

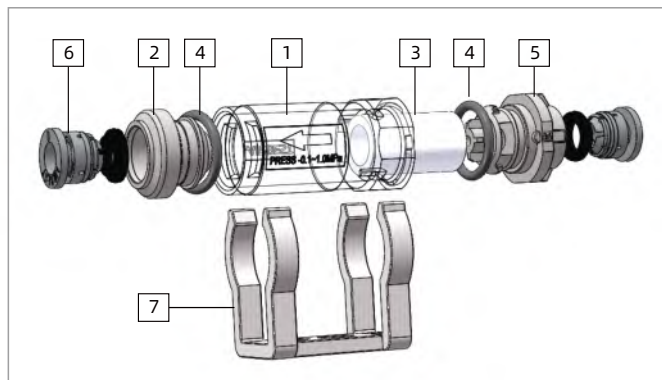

NO.	Item	Material	Q'ty
1	Housing	PC	1
2	Rear cap	PBT	1
3	Filter element	PE	1
4	O-ring	NBR	2
5	Front cap	PBT	1
6	One-touch fitting	-	2
7	Bracket	PBT	1

### Repair kits

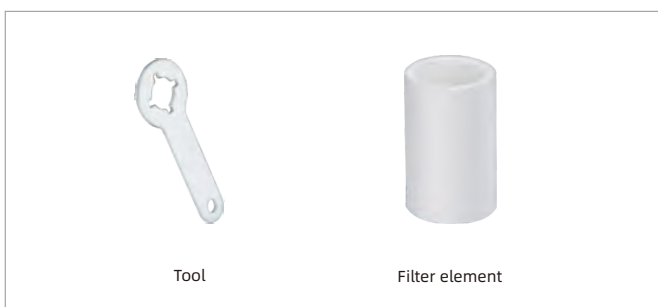

Item	Model	Dimension	Applicable vacuum filter
Tool	ZFA5-SP	-	ZFA54, 56
	ZFA7-SP	-	ZFA76, 78, 710, 712
Filter element	ZFA5-FE	8×12×L20	ZFA54, 56
	ZFA7-FE	12×16×L25	ZFA76, 78, 710, 712

◇ Note: The minimum packing quantity of filter element is 10pcs/bag.

### Filter element replacement

1. Stop supplying air and reduce the pressure in the vacuum filter to atmospheric pressure
2. Put tool on the front cap and turn it 90° anti-clockwise
3. Pull out the front cap, remove the filter element, and if there is dust inside the housing, clean it with an air gun (make sure that it does not damage the O-ring)
4. Install new filter element on the front cap and insert it into the housing.
5. Align the side without number of front cap at the limit mark, and push it until touching the housing
6. Rotate clockwise with the tool until it stops (align the number at the limit mark)

★ When using the filter in positive pressure environment, do not connect the filter behind the solenoid valve, which will cause the filter to withstand frequent shocks if solenoid valve is long-term frequent on-off

### Cautions:

1. When connecting the hose, check the arrow indicating the flow direction. If reverse connecting, airtightness of the filter element cannot be ensured
2. In one air line, positive and negative pressure should not be used at the same time
3. Please make sure not to damage the O-ring during assembling and disassembling. And please confirm that there is no air leakage after the filter element is replaced
4. The vacuum filter and hose shall not withstand external force such as torsion, pull, load, vibration, impact, etc., and external force may cause danger at high positive pressure
5. There is anti-rotating structure at the limit mark. After replacing the filter element, please confirm the position of the limit mark
6. Please use vacuum filter at rated working pressure
7. Compressed air operation may cause danger. Therefore, filter replacement and other maintenance should be operated by a person who has sufficient knowledge and experience in air mechanics while complying with product specifications

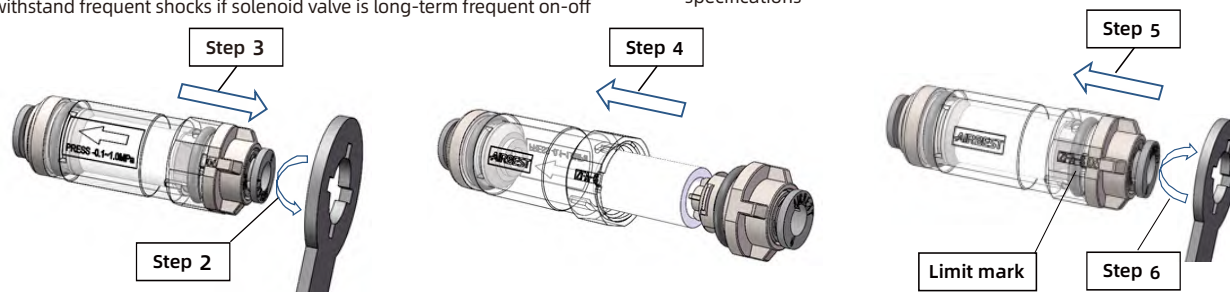

# ZFD Series

## Mini Type Vacuum Filter



UNIVERSAL



### Features

- ◇ Filter dust and other particles from the vacuum port
- ◇ Transparent housing, easy to check the degree of contamination
- ◇ Directly connect to vacuum port of vacuum generator, eg. AZR series
- ◇ Pipe type design, connect to hose directly
- ◇ Compact structure and small size, light weight, economy and environmental protection



### How to order

## ZFD 06

① ②

① Series	② Connection specification
ZFD	04 - $\phi$ 4hose 06 - $\phi$ 6hose

### Technical parameters

Model	Rated operating pressure range kPa	Material	Nominal flow NL/min	Removal efficiency $\mu$ m	Working temperature $^{\circ}$ C	Weight g
ZFD04	-100~0	PP、PE	27	10	0~60	1.5
ZFD06	-100~0	PP、PE	49	10	0~60	2.5

### Dimensions (mm)

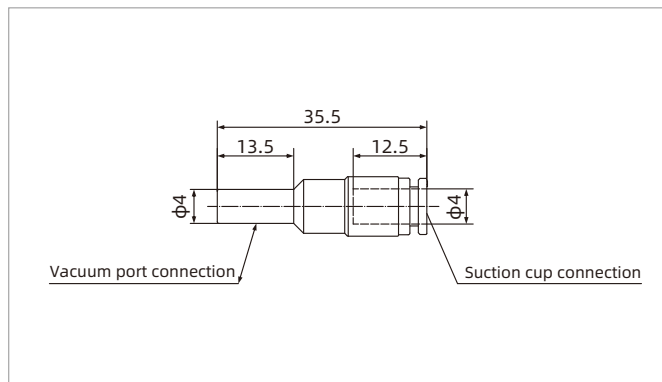

ZFD04

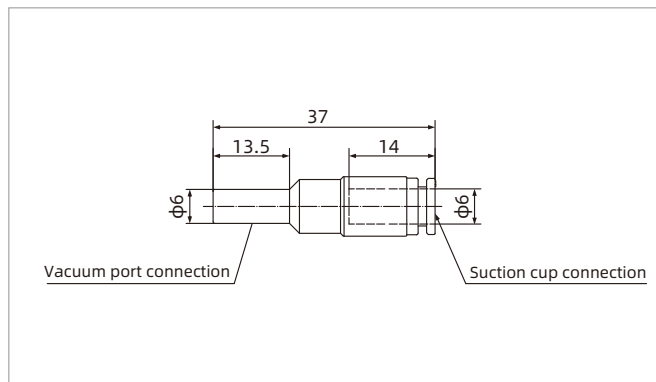

ZFD06

# ZFB Series

## Universal Vacuum Filter

**AIRBEST**



UNIVERSAL



### Features

- ◇ Filter dust and other particles from the vacuum port
- ◇ Transparent housing, easy to check the degree of contamination
- ◇ Filter elements could be replaced
- ◇ Different nominal flow for option
- ◇ Suitable for vacuum system with light and medium pollution level
- ◇ Could be used for as prefilter, it can effectively filter dust with different degrees



### How to order

**ZFB 15 B**  
①      ②      ③

① Series	② Connection thread	③ Bracket
ZFB	10 - G3/8 female thread 15 - G1/2 female thread 20 - G3/4 female thread 25 - G1" female thread 40 - G1"1/2 female thread	B - Default, with bracket

### Selection

Model/Connection thread		20 - G3/4	25 - G1"	40 - G1"1/2
10 - G3/8	15 - G1/2			
ZFB10B	ZFB15B	ZFB20B	ZFB25B	ZFB40B

### Technical parameters

Model	Rated operating pressure range kPa	Material	Nominal flow NL/min	Internal volume cm <sup>3</sup>	Filter area m <sup>2</sup>	Removal efficiency μm	Working temperature °C	Weight g
ZFB10B	-100~0	PA, PC, PE	150	45	0.003	10	-20~80	70
ZFB15B	-100~0	PA, PC, PE	900	195	0.010	10	-20~80	168
ZFB20B	-100~0	PA, PC, PE	900	205	0.010	10	-20~80	170
ZFB25B	-100~0	PA, PC, PE	2,520	495	0.019	10	-20~80	424
ZFB40B	-100~0	PA, PC, PE	5,100	675	0.023	10	-20~80	550

Vacuum Accessories

- ZFS
- ZFA
- ZFD
- ZFB
- ZFL
- ZFP
- ZVAB
- ZVAC
- ZVEA
- ZVR
- ZVRM
- ZVCM
- ZVD
- ZVS
- ZPDT
- ZPDE
- ZPMR
- ZSA

# ZFB Series

## Universal Vacuum Filter



### Dimensions (mm)

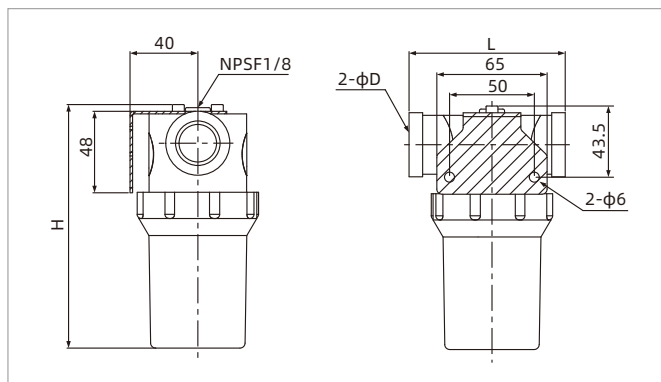

ZFB10(15-20)B

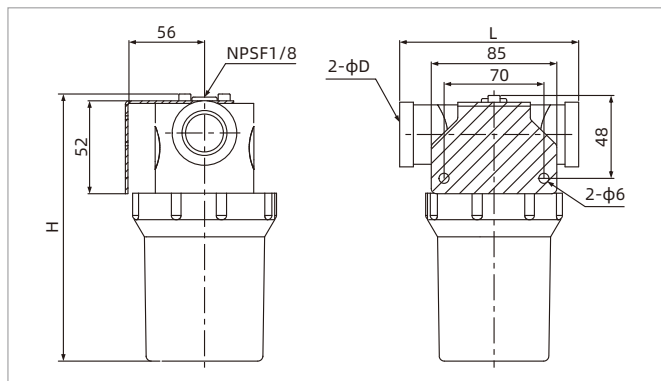

ZFB25B ZFB40B

Model/Size	H	L	D
ZFB10B	74.5	76.5	2-G3/8
ZFB15B	134.5	91.5	2-G1/2
ZFB20B	143.5	92	2-G3/4

Model/Size	H	L	D
ZFB25B	169.5	127	2-G1"
ZFB40B	212.5	127	2-G1"1/2

### Repair kits



Item	Model	Size	Applicable vacuum filter
Filter element	ZFB10-FE	15×26×L35	ZFB10
	ZFB20-FE	27.5×39×L90	ZFB15、20
	ZFB25-FE	45×57×L104	ZFB25
	ZFB40-FE	45×57×L136	ZFB40

◇ Note: The minimum packing quantity of filter element is 10pcs/bag

# ZFL Series

## Inline Vacuum Filter



UNIVERSAL



### Features

- ◇ Filter dust and other small particles from the vacuum port
- ◇ Transparent housing, easy to indicate degree of contamination
- ◇ It can be connected directly to the vacuum port of the vacuum generator, such as ABM and ABX, etc.
- ◇ Compact structure and small size, light weight, economic and environmental protective



### How to order

**ZFL 06**

① ②

① Series	② Port size
ZFL	06 - $\phi 6$ hose(Direct-insert type) 10 - G3/8 male thread

### Technical parameters

Model	Rated operating pressure range kPa	Material	Nominal flow NL/min	Internal volume $\text{cm}^3$	Removal efficiency $\mu\text{m}$	Working temperature $^{\circ}\text{C}$	Weight g
ZFL06	-100~0	PP、PE	25	4	20~25	0~80	3.5
ZFL10	-100~0	PP、PE	220	20	20~25	0~80	13

### Dimensions (mm)

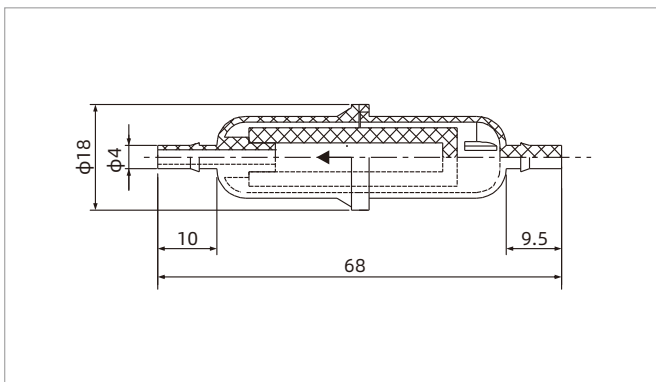

ZFL06

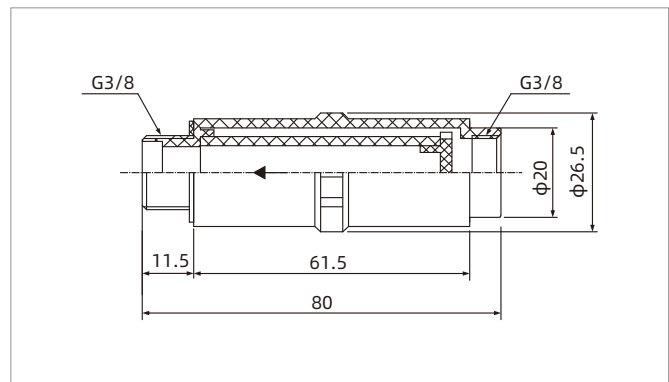

ZFL10

Vacuum Accessories

ZFS

ZFA

ZFD

ZFB

**ZFL**

ZFP

ZVAB

ZVAC

ZVEA

ZVR

ZVRM

ZVCM

ZVD

ZVS

ZPDT

ZPDE

ZPMR

ZSA

# ZFP Series

## Large-flow Vacuum Filter



UNIVERSAL

### Features

- ◇ It can effectively prevent solid particles or dust from being sucked into the vacuum generator or system, reduce wear, improve operation reliability, extend the lifetime of the vacuum generator, and also effectively protect components of vacuum system (such as vacuum valve, vacuum gauge, etc.)
- ◇ All-steel structure, sturdy and durable, suitable for heavy load requirements of industrial use, adopts seamless tensile metal housing with copper welding joint, which has the advantages of high air tightness, large space for dirt, easy cleaning, easy replacement of filter element, and quick inlet and outlet with threaded connection
- ◇ Various nominal flow rates for option



### How to order

## ZFP 30

① ②

① Series	② Nominal flow
ZFP	30 - 32m <sup>3</sup> /h
	40 - 42m <sup>3</sup> /h
	100 - 100m <sup>3</sup> /h
	120 - 120m <sup>3</sup> /h
	300 - 300m <sup>3</sup> /h

### Selection

Model/Nominal flow 30 - 32m <sup>3</sup> /h	40 - 42m <sup>3</sup> /h	100 - 100m <sup>3</sup> /h	120 - 120m <sup>3</sup> /h	300 - 300m <sup>3</sup> /h
ZFP30	ZFP40	ZFP100	ZFP120	ZFP300

### Technical parameters

Model	Rated operating pressure range kPa	Body material	Nominal flow m <sup>3</sup> /h	Internal volume cm <sup>3</sup>	Filter area cm <sup>2</sup>	Removal efficiency μm	Working temperature °C	Weight kg
ZFP30	-100~0	Steel	32	45	30	10	-15~90	1
ZFP40	-100~0	Steel	42	195	100	10	-15~90	1
ZFP100	-100~0	Steel	100	205	100	10	-15~90	1.4
ZFP120	-100~0	Steel	120	495	190	10	-15~90	2.3
ZFP300	-100~0	Steel	300	675	230	10	-15~90	6.9

# ZFP Series

## Large-flow Vacuum Filter

### Dimensions (mm)

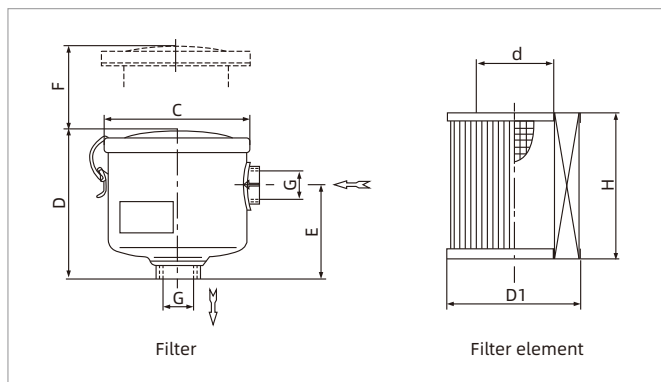

Model/Size	G	C	D	E	F	D1	d	H
ZFP30	G1/2	101	90	53	70	65	38	69
ZFP40	G3/4	101	90	53	70	65	38	69
ZFP100	G1"1/4	146	110	70	75	98	60	70
ZFP120	G1"1/4	185	170	115	130	128	64	125
ZFP300	G2"	222	258	125	140	150	88	222

ZFP

### Repair kits



Item	Model	Applicable vacuum filter
Filter element	ZFP30-FE	ZFP30, 40
	ZFP100-FE	ZFP100
	ZFP120-FE	ZFP120
	ZFP300-FE	ZFP300

Vacuum Accessories

ZFS

ZFA

ZFD

ZFB

ZFL

**ZFP**

ZVAB

ZVAC

ZVEA

ZVR

ZVRM

ZVCM

ZVD

ZVS

ZPDT

ZPDE

ZPMR

ZSA

# ZVAB Series

## Pneumatic Control Valve



UNIVERSAL

### Features

- ◇ Converts vacuum signal into pneumatic signal
- ◇ Different vacuum ranges are set by adjusting the screws on the valve
- ◇ There are two different valves for option: normally open valve and normally closed valve



### How to order

## ZVAB - NC

①                      ②

① Series	② Function	Connection thread
ZVAB	NC - Normally closed NO - Normally open	Default, G1/8 male thread

### Technical parameters

Model	Output function	Air supply pressure bar	Signal range -kPa	Hysteresis -kPa	Working temperature °C	Weight g
ZVAB-NC	NC	1.5~8	15~95	12	-10~60	44
ZVAB-NO	NO	1.5~8	10~95	3	-10~60	44

### Symbol

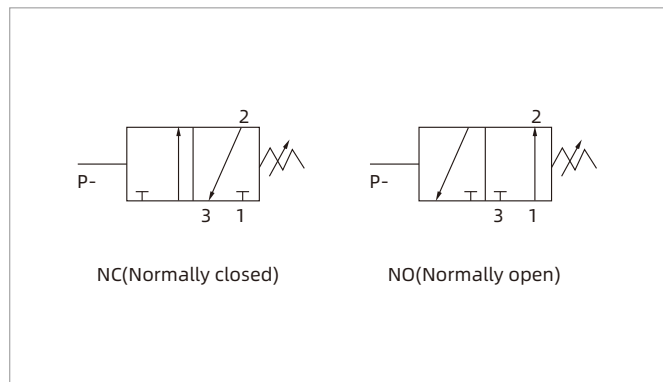

ZVAB-NC

ZVAB-NO

### Dimensions (mm)

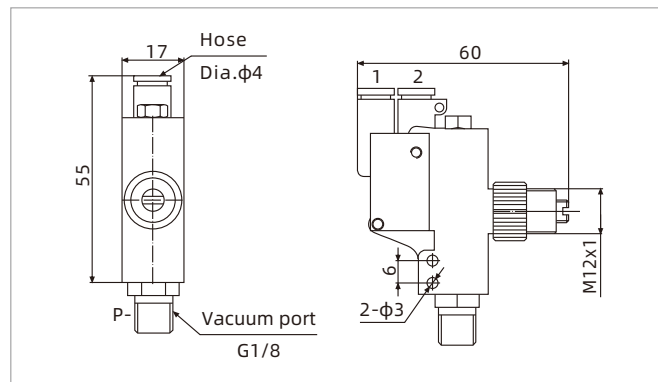

ZVAB

# ZVAC Series

## Pneumatic Control Valve



UNIVERSAL

### Features

- ◇ Be used with ZVAB-NC
- ◇ ZVAB-NC provides the air control signal to realize the opening and closing of the control valve and save energy



### How to order

ZVAC - NO  
①                      ②

① Series	② Function	Connection thread
ZVAC	NO - Normally open	Default, G1/8 male thread

### Technical parameters

Model	Air supply pressure bar	Control mode	Action mode	Working temperature °C	Weight g
ZVAC-NO	1.0~8.0	Pneumatic control	NO	0~60	55

### Dimensions (mm)

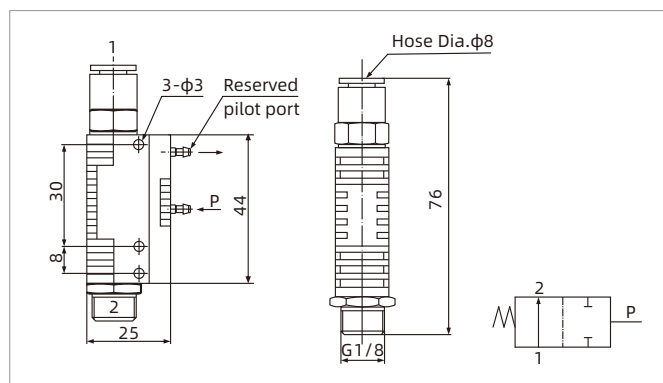

ZVAC-NO

### Energy-saving system

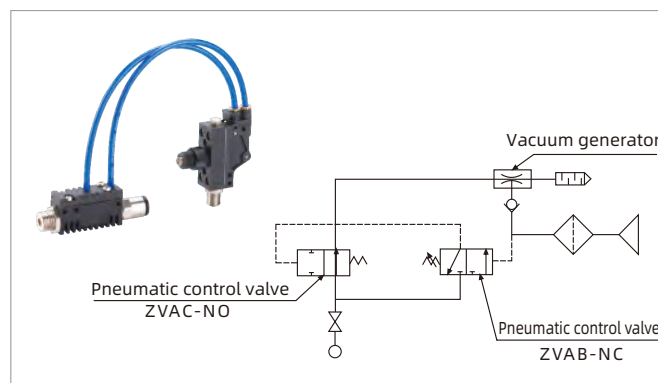

ZVU-ES

# ZVEA Series

## Electric Control Valve



UNIVERSAL



### Features

- ◇ The small valve (normally closed) can realize remote control of high flow compressed air and can supply compressed air when the current is switched



### How to order

## ZVEA - G1F

①                      ②

#### ① Series

ZVEA

#### ② Connection thread

G1F - G1/8 female thread  
G2F - G1/4 female thread

### Technical parameters

Model	Air supply pressure bar	Valve body material	Output function	Operating voltage V	Consumed power W	Working temperature °C	Weight g
ZVEA-G1F	3.5~7.0	Aluminum alloy	NC	DC24	0.85	0~60	84
ZVEA-G2F	3.5~7.0	Aluminum alloy	NC	DC24	0.85	0~60	165

### Dimensions (mm)

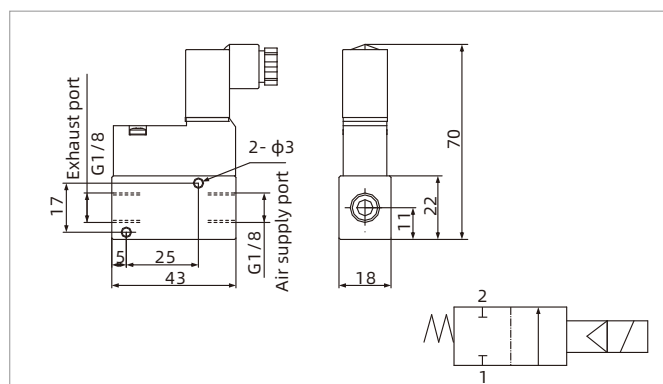

ZVEA-G1F

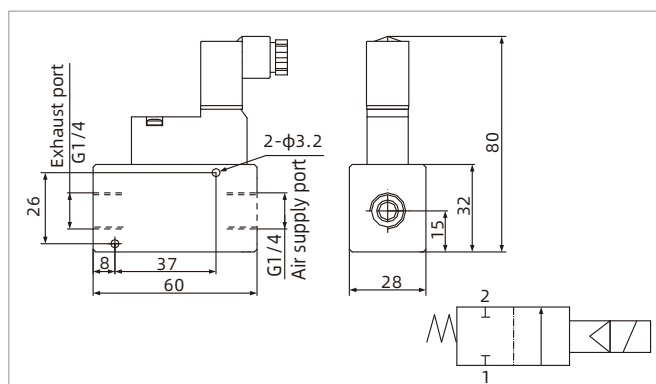

ZVEA-G2F

# ZVR Series

## Check Valve



UNIVERSAL



### Features

- ◇ In the process of grabbing the workpiece, it will not affect the whole vacuum system once suction cups failed to adsorb the workpiece or the workpiece falls off suddenly after adsorption
- ◇ In the above case, the suction cups are isolated from vacuum system to make sure that the vacuum level and vacuum flow in the whole vacuum system are maintained. It is specific for repeatedly gripping workpieces with various sizes and shapes in a vacuum system



Vacuum Accessories

### How to order

## ZVR 05 - G1M

①      ②      ③

① Series	② Overflow port diameter	③ Suction cup connection thread
ZVR	04 - $\phi$ 0.4mm	M5M - M5 $\times$ 0.8 male thread    M5F - M5 $\times$ 0.8 female thread
	05 - $\phi$ 0.5mm	G1M - G1/8 male thread        G1F - G1/8 female thread
	06 - $\phi$ 0.6mm	G2M - G1/4 male thread        G2F - G1/4 female thread
	10 - $\phi$ 1.0mm	G3M - G3/8 male thread        G3F - G3/8 female thread
	12 - $\phi$ 1.2mm	G4M - G1/2 male thread        G4F - G1/2 female thread

ZFS

ZFA

ZFD

ZFB

ZFL

ZFP

ZVAB

ZVAC

ZVEA

ZVR

ZVRM

ZVCM

ZVD

ZVS

ZPDT

ZPDE

ZPMR

ZSA

### Selection

Model/ Connection thread M - Male thread	F - Female thread
ZVR04-M5M	ZVR04-M5F
ZVR05-G1M	ZVR05-G1F
ZVR06-G2M	ZVR06-G2F
ZVR10-G3M	ZVR10-G3F
ZVR12-G4M	ZVR12-G4F

### Air circuit schematic diagram

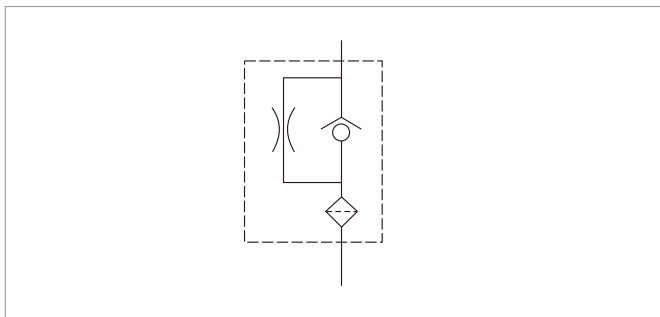

# ZVR Series

## Check Valve



UNIVERSAL

### Technical parameters

Model	Minimum close flow NL/min(-30kPa)	Minimum close flow NL/min(-60kPa)	Max. blow flow NL/min	Weight g
ZVR04-M5□	1.2	1.3	80	2
ZVR05-G1□	2.3	2.5	310	8.3
ZVR06-G2□	2.9	3.4	340	15.6
ZVR10-G3□	7.3	8	590	28.6
ZVR12-G4□	8.1	9	790	46

### Dimensions (mm)

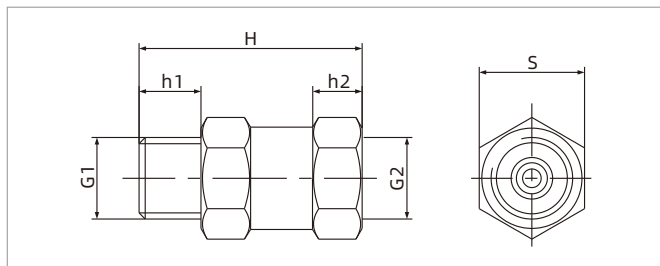

ZVR

Model/Size	H	G1	h1	G2	h2	S
ZVR04-M5□	20	M5×0.8	4.5	M5×0.8	5	8
ZVR05-G1□	28	G1/8	8	G1/8	6	14
ZVR06-G2□	36	G1/4	10	G1/4	8	17
ZVR10-G3□	39	G3/8	10	G3/8	8	22
ZVR12-G4□	41	G1/2	12	G1/2	9	27

# ZVRM Series

## Check Valve



UNIVERSAL



### Features

- ◇ Effectively avoid the influence to the whole vacuum system when the suction cup failed to adsorb the workpiece
- ◇ In the same vacuum system, workpieces of different sizes can be repeatedly grasped
- ◇ Spring type check valve helps to prevent workpiece from dropping in turnover movement



### How to order

## ZVRM 07 - M5M

①      ②      ③

① Series	② Overflow port diameter	③ Suction cup connection thread
ZVRM	03 - $\phi$ 0.3mm 05 - $\phi$ 0.5mm 07 - $\phi$ 0.7mm 10 - $\phi$ 1.0mm	M5M - M5x0.8 male thread G1M - G1/8 male thread

### Selection

Model/Thread M5M	G1M
ZVRM03-M5M	-
ZVRM05-M5M	ZVRM05-G1M
ZVRM07-M5M	ZVRM07-G1M
-	ZVRM10-G1M

### Technical parameters

Model	Overflow port diameter mm	Valve core works Effective cross-sectional area mm <sup>2</sup>	Valve core doesn't work Effective cross-sectional area mm <sup>2</sup>	Fluid	Max. pressure range kPa	Removal efficiency $\mu$ m	Minimum close flow NL/min	Weight g
ZVRM03-M5M	0.3	0.07	1.64	Air	-100~0	40	2	6
ZVRM05-M5M	0.5	0.19	1.76	Air	-100~0	40	4	6
ZVRM07-M5M	0.7	0.38	1.95	Air	-100~0	40	5.5	6
ZVRM05-G1M	0.5	0.19	1.76	Air	-100~0	40	5	22
ZVRM07-G1M	0.7	0.38	2.64	Air	-100~0	40	8	22
ZVRM10-G1M	1.0	0.78	3.04	Air	-100~0	40	16	22

Vacuum Accessories

ZFS

ZFA

ZFD

ZFB

ZFL

ZFP

ZVAB

ZVAC

ZVEA

ZVR

ZVRM

ZVCM

ZVD

ZVS

ZPDT

ZPDE

ZPMR

ZSA

# ZVRM Series

## Check Valve

### Dimensions (mm)

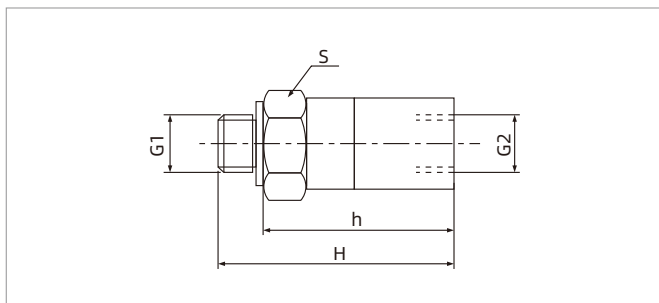

ZVRM

Model/Size	H	h	G1	G2	S
ZVRM03-M5M	20	16	M5×0.8depth3.5	M5×0.8depth6	8
ZVRM05-M5M	20	16	M5×0.8depth3.5	M5×0.8depth6	8
ZVRM07-M5M	20	16	M5×0.8depth3.5	M5×0.8depth6	8
ZVRM05-G1M	28.5	23	G1/8depth5	G1/8depth8.5	13
ZVRM07-G1M	28.5	23	G1/8depth5	G1/8depth8.5	13
ZVRM10-G1M	28.5	23	G1/8depth5	G1/8depth8.5	13

### Air circuit schematic diagram

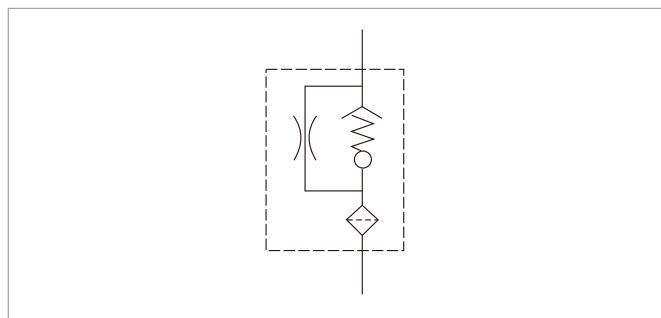

# ZVCM Series

## Non-Return Valve

**AIRBEST**



UNIVERSAL



### Features

- ◇ It can keep vacuum level of the system in case of power failure when vacuum line is closed
- ◇ Small size, can be used in narrow space



### Selection

## ZVCM - M5F

①

②

① Series

② Vacuum generator connection thread

ZVCM

M5F- M5×0.8 female thread

G1F - G1/8 female thread

### Technical parameters

Model	Valve core works Effective cross-sectional area mm <sup>2</sup>	Fluid	Max. pressure range kPa	Removal efficiency μm	Weight g
ZVCM-M5F	2.0	Air	-100~0	40	6
ZVCM-G1F	5.0	Air	-100~0	40	22

### Air circuit schematic diagram

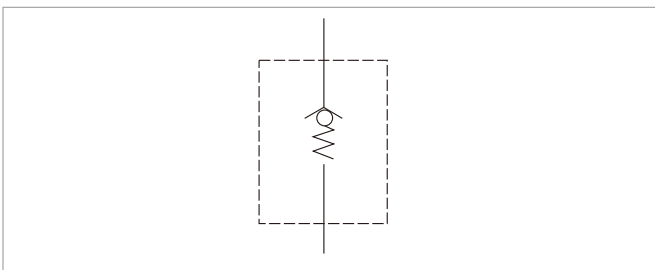

### Dimensions(mm)

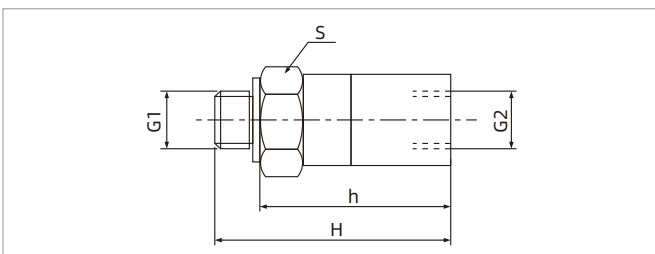

Model/Size	H	h	G1	G2	S
ZVCM-M5F	20	16	M5×0.8	M5×0.8	8
ZVCM-G1F	28.5	23	G1/8	G1/8	13

ZVCM

Vacuum Accessories

ZFS

ZFA

ZFD

ZFB

ZFL

ZFP

ZVAB

ZVAC

ZVEA

ZVR

ZVRM

ZVCM

ZVD

ZVS

ZPDT

ZPDE

ZPMR

ZSA

# ZVD Series

## Touch Valve

**AIRBEST**



UNIVERSAL



### Features

- ◇ It is used to induct whether the suction cup touches the workpiece, the vacuum system cannot be established without touch



### How to order

## ZVD - G2M

①                      ②

#### ① Series

ZVD

#### ② Specification

G2M - Mounting thread G1/4  
G4M - Mounting thread G1/2

### Selection

Model	Mounting thread	Starting elastic force	Weight g
ZVD-G2M	G1/4	5	41.5
ZVD-G4M	G1/2	6.6	96.5

### Dimensions(mm)

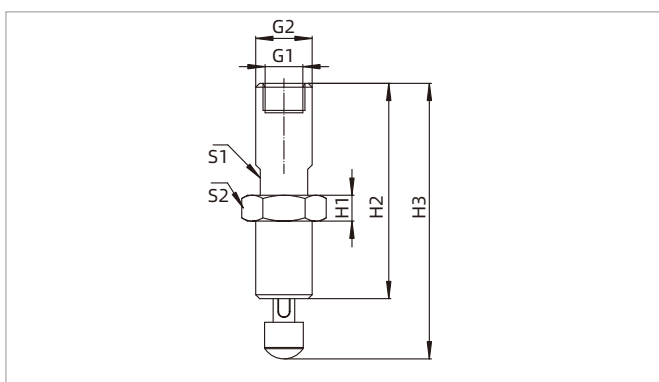

Model/Size	G1	G2	S1	S2	H1	H2	H3
ZVD-G2M	G1/8	G1/4	11	17	6	50	64
ZVD-G4M	G3/8	G1/2	18	27	8	54.5	68.5

# ZVS Series

## Fast Blow-off Valve



UNIVERSAL



### Features

- ◇ It is connected with the suction cup, can effectively seal the vacuum and break the vacuum under the condition of positive pressure input

### Advantages

- ◇ Low startig pressure with stable and fast blow-off even if there are multiple suction cups working at the same time
- ◇ Fast vacuum break as it is mounted directly on the suction cup



### Application

- ◇ Fast blow-off to break vacuum
- ◇ The blow-off air flow can clean the suction cup as it is mounted directly on the suction cup

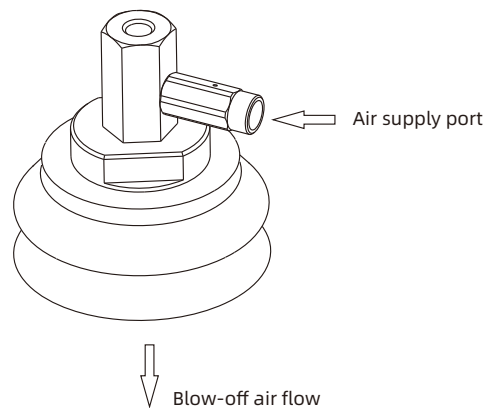

### Structure

- ◇ (1) Air supply port
- ◇ (2) Main body
- ◇ (3) Exhaust port

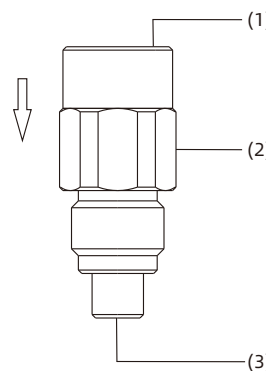

# ZVS Series

## Fast Blow-off Valve

### How to order

## ZVS - G1F

①                      ②

① Series	② Air supply port connection thread	Exhaust port connection thread
ZVS	G1F - G1/8 female thread G2F - G1/4 female thread	G1/8 male thread G1/4 male thread

### Technical parameters

Model	Air supply pressure range bar	Max. blow flow NL/min	Working temperature °C	Weight g	Recommended hose dia. mm
ZVS-G1F	3.0~7.0	90~160	-10~80	12.9	φ8
ZVS-G2F	3.0~7.0	90~160	-10~80	15.1	φ8

### Pneumatic schematic diagram

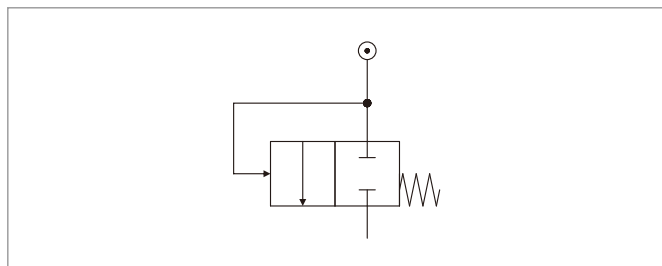

### Dimensions (mm)

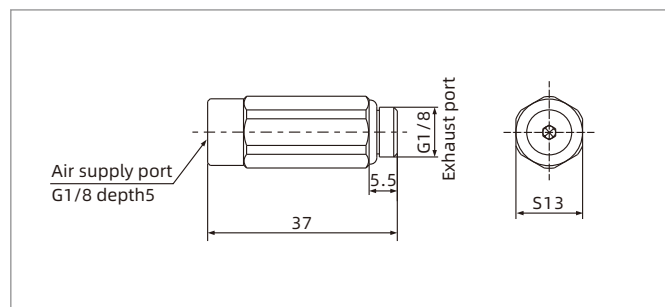

ZVS-G1F

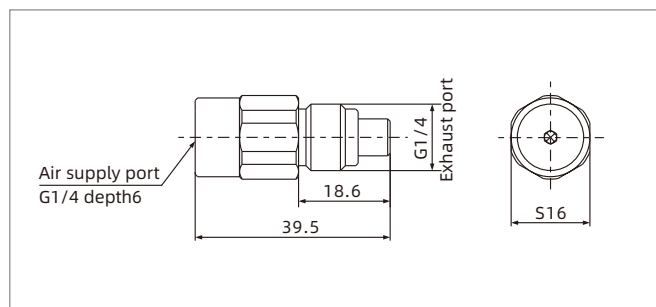

ZVS-G2F

# ZPDT Series

## High-precision Digital Pressure Switch



UNIVERSAL



### Features

- ◇ Digital display electronic pressure switch, optional two-color display
- ◇ 4-digit seven-segment LED display
- ◇ Pressure units can be converted and displayed on the screen
- ◇ Parameter values can be displayed directly on the screen

### Advantages

- ◇ Monitor the system action clearly and visually, could change the setting content and backlight display mode
- ◇ The pressure is displayed on the screen, easy to read
- ◇ Main and sub display can set parameter directly, setting steps could be reduced by 3/4
- ◇ Easy to operate with the clear display



### Application

- ◇ Monitor the vacuum system, optimize the working cycle
- ◇ Adjust the system circuit, improve economic benefit of vacuum system
- ◇ Square shape is more suitable for installing panel
- ◇ Suitable for all automation handling industries

### Structure

- ◇ Electronic vacuum switch, solid polycarbonate case
- ◇ Vacuum connection is Rc1/8 Male thread
- ◇ 2m connecting cable
- ◇ Optional mounting bracket and panel type mounting frame

### How to order

**ZPDT - C NV - R1M**  
 ①            ②    ③            ④

Series	Pressure range	Output specification	Connection thread
ZPDT	C - Compound P - Positive	NV - 1NPN+1 Analog(Voltage) output (1-5V) PV - 1PNP+1 Analog(Voltage) output(1-5V)	R1M - Rc1/8 male thread

### Selection

Model Nil			
ZPDT-CNV-R1M	ZPDT-CPV-R1M	ZPDT-PNV-R1M	ZPDT-PPV-R1M

Vacuum Accessories

- ZFS
- ZFA
- ZFD
- ZFB
- ZFL
- ZFP
- ZVAB
- ZVAC
- ZVEA
- ZVR
- ZVRM
- ZVCM
- ZVD
- ZVS
- ZPDT
- ZPDE
- ZPMR
- ZSA

# ZPDT Series



## High-precision Digital Pressure Switch

### Technical parameters

Model	ZPDT-C (Compound)	ZPDT-P (Positive)
Rated pressure range	-100.0~100.0kPa	-0.100~1.000MPa
Setting pressure range	-103.0~103.0kPa	-0.103~1.030MPa
Withstand pressure	500kPa	1.5MPa
Fluid	Air, Non-corrosive gas/Non-flammable gas	Air, Non-corrosive gas/Non-flammable gas
Pressure unit	kPa	-
Set pressure resolution	MPa	0.001
	kgf/cm <sup>2</sup>	0.01
	bar	0.01
	psi	0.1
	inHg	-
	mmHg	-
Power supply voltage	12 to 24V DC±10%, ripple(P-P)10% or less	
Current consumption	≤40mA (Without load)	
Switch output	Output type	Open collector (NPN or PNP)
	load current	Max.125mA
	Residual voltage	≤1.0V
	Response time	≤2.5ms (Chattering-proof function: 25ms,100ms,250ms, 500ms, 1000ms, 1500ms selectable)
Analog output	Output Voltage	1-5V ±2.5%F.S (within rated pressure range)   0.6-5V ±2.5%F.S (within rated pressure range)
	Output impedance	1kΩ
	Linearity	±1% F.S.
Display	Display	Three colors (Red/ Green/ Orange)display(sampling rate:5 times/sec,2 times/sec,1 time/sec for choice.)
	Indicator accuracy	±1%F.S.±1 digit (ambient temperature: 25±3°C)
	Repeatability	±0.3%F.S.±1 digit
	Switch ON indicator	Orange (1 indicator)OUT1
Environment	Enclosure	IP40
	Ambient temp.range	0~50°C
	Temperature characteristic	±3% F.S.of rated ambient temperature 25°C (at temp. range of 0~50°C)
	Storage temperature	Storage: -10-60°C (No condensation or freezing)
	Ambient humidity	Operation/ storage:35-85%HR (No condensation)
	Withstand voltage	1000VAC in 1-min (between case and lead wire)
	Insulation resistance	50MΩ min (500V DC) (between case and lead wire)
	Vibration	Total amplitude 1.5mm Or 10G, 10Hz~150Hz~10Hz for 1 minute, two hours each direction of X, Y and Z
	Shock	100m/s <sup>2</sup> (10G) 3 times each in direction of X, Y and Z
Port size	Rc1/8, M5	
Lead wire	Oil-resistance cable (0.15mm <sup>2</sup> )	
Weight	67g (with 2-meter lead wire)	

# ZPDT Series

## High-precision Digital Pressure Switch



### Output circuit wiring diagrams

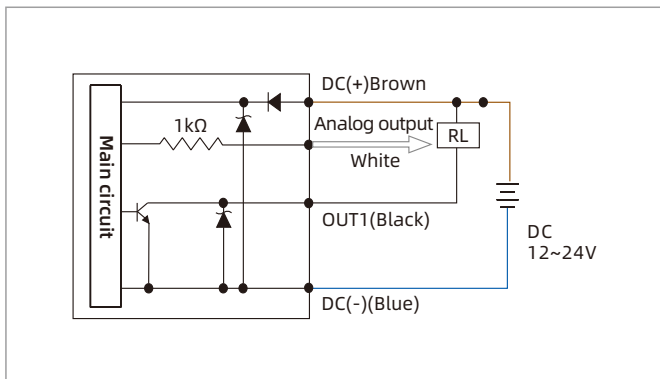

ZPDT-□NV-R1M 1NPN+Analog voltage output (1-5V)

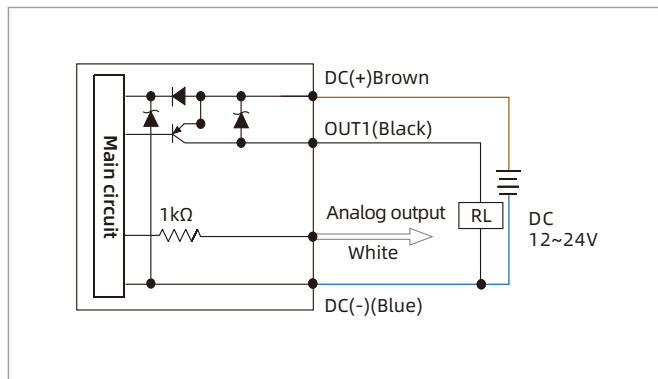

ZPDT-□PV-R1M 1PNP+Analog voltage output (1-5V)

### Panel instructions

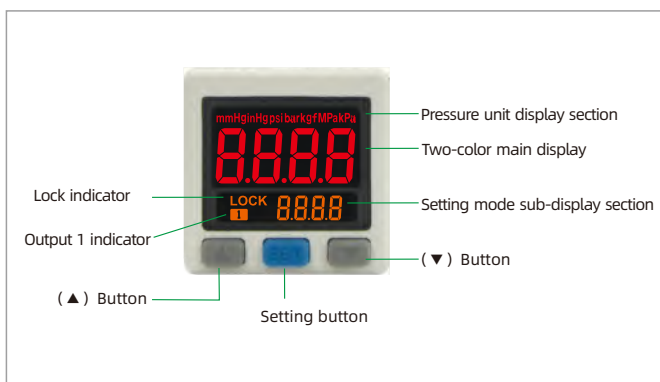

### Dimensions(mm)

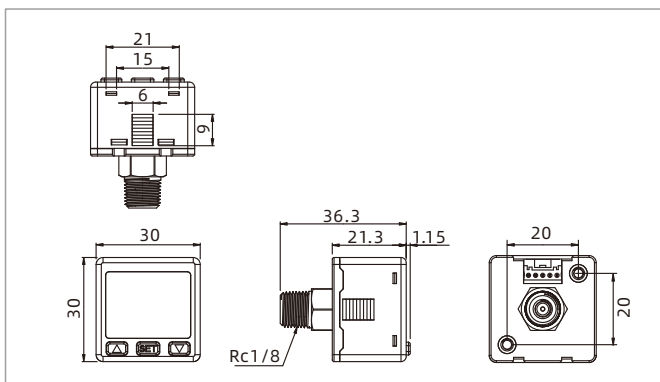

ZPDT-□□-R1M

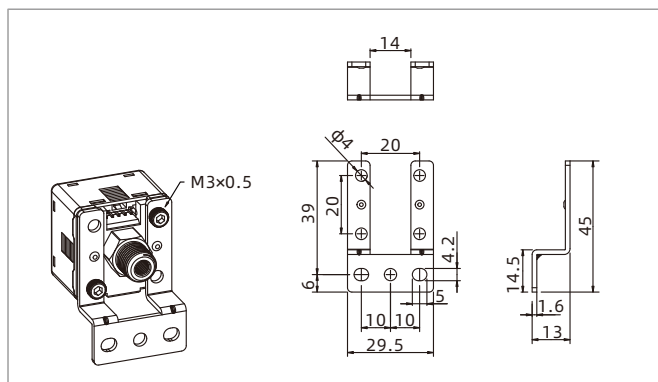

ZPDT-A-MB Mounting bracket A type

- Vacuum Accessories
- ZFS
- ZFA
- ZFD
- ZFB
- ZFL
- ZFP
- ZVAB
- ZVAC
- ZVEA
- ZVR
- ZVRM
- ZVCM
- ZVD
- ZVS
- ZPDT
- ZPDE
- ZPMR
- ZSA

# ZPDT Series

## High-precision Digital Pressure Switch

### Dimensions (mm)

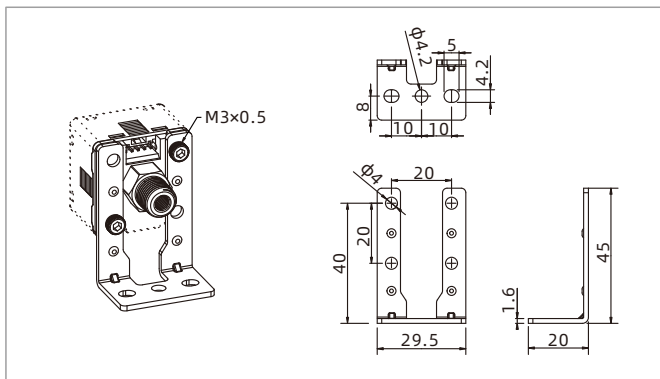

ZPDT-B-MB Mounting bracket B type

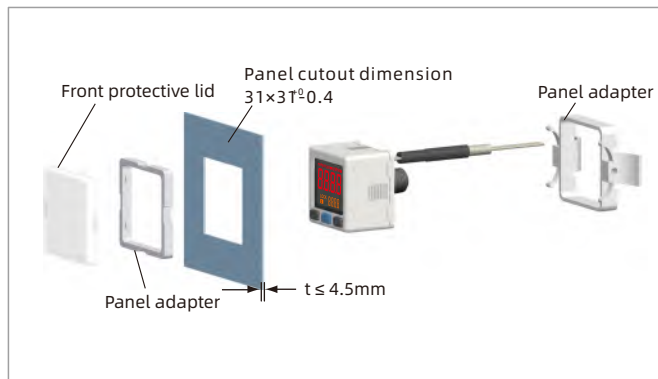

Panel type

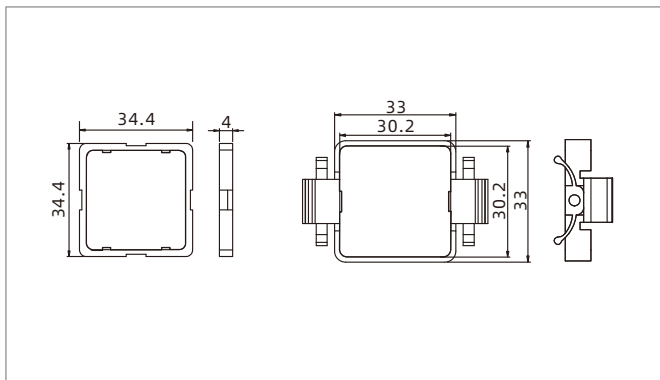

ZPDT-PS Panel adapter

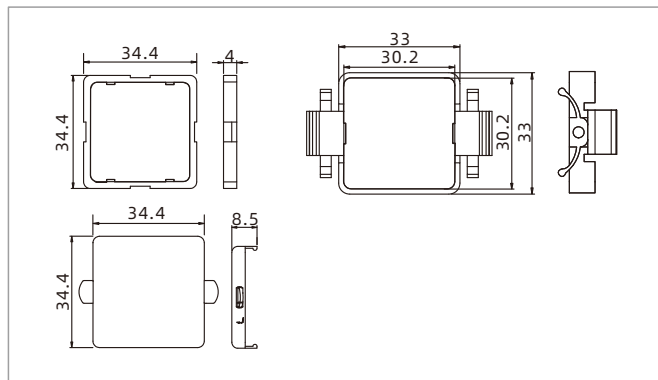

ZPDT-PC Front protective lid + panel adapter

### Accessories

Item	Model
Mounting bracket A type	ZPDT-A-MB
Mounting bracket B type	ZPDT-B-MB
Panel adapter	ZPDT-PS
Front protective lid + panel adapter	ZPDT-PC

# ZPDE Series

## High-precision Digital Pressure Switch

**AIRBEST**



UNIVERSAL



### Features

- ◇ Digital display electronic pressure switch, optional two-color display
- ◇ 4-digit seven-segment LED display
- ◇ Pressure units can be converted and displayed on the screen
- ◇ Parameter values can be displayed directly on the screen

### Advantages

- ◇ Monitor the system action clearly and visually, could change the setting content and backlight display mode
- ◇ The pressure is displayed on the screen, easy to read
- ◇ Easy to operate with the clear display



### Application

- ◇ Monitor the vacuum system, optimize the working cycle
- ◇ Adjust the system circuit, improve economic benefit of vacuum system
- ◇ Square shape is more suitable for installing panel
- ◇ Suitable for all automation handling industries

### Structure

- ◇ Electronic vacuum switch, solid polycarbonate case
- ◇ 2m connecting cable
- ◇ Optional mounting bracket and panel type mounting frame

### How to order

ZPDE - C N - R1M  
 ①            ②    ③            ④

① Series	② Pressure range	③ Output specification	④ Connection thread
ZPDE	C - Compound P - Positive	N - 1NPN output P - 1PNP output	R1M - Rc1/8 male thread

### Selection

Model	
ZPDE-CN-R1M	ZPDE-PN-R1M
ZPDE-CP-R1M	ZPDE-PP-R1M

Vacuum Accessories

- ZFS
- ZFA
- ZFD
- ZFB
- ZFL
- ZFP
- ZVAB
- ZVAC
- ZVEA
- ZVR
- ZVRM
- ZVCM
- ZVD
- ZVS
- ZPDT
- ZPDE
- ZPMR
- ZSA

# ZPDE Series

## High-precision Digital Pressure Switch



### Technical parameters

Model		ZPDE-C (Compound)	ZPDE-P (Positive)
Rated pressure range		-100.0~100.0kPa	-0.100~1.000MPa
Setting pressure range		-103.0~103.0kPa	-0.103~1.030MPa
Withstand pressure		500kPa	1.5MPa
Fluid		Air, Non-corrosive gas/Non-flammable gas	Air, Non-corrosive gas/Non-flammable gas
Pressure unit	kPa	0.1	1
Set pressure resolution	MPa	-	-
	kgf/cm <sup>2</sup>	0.001	0.01
	bar	0.001	0.01
	psi	0.01	0.1
	inHg	0.1	-
	mmHg	1	-
Power supply voltage		12to24V DC±10%,ripple(P-P)10% or less	
Current consumption		≤30mA (Without load)	
Switch output	Output type	Open collector (NPN) / Close collector (PNP)	
	Load current	Max.125mA	
	Residual voltage	≤1.0V	
	Response time	≤2.5ms(Chattering-proof function:25ms,100ms,250ms,500ms,1000ms,1500ms selectable)	
Display	Display	White (Sampling rate:0.2 time/sec,0.5 time/sec,1 time/sec for choice)	
	Indicator accuracy	±1%F.S.±1 digit (ambient temperature:25±3°C)	
	Repeatability	±0.3%F.S.±1 digit	
	Switch ON Indicator	White (1 indicator) OUT1	
Environment	Enclosure	IP40	
	Ambient temp. range	0~50°C	
	Temperature characteristic	±2% F.S.of rated ambient temperature 25°C (at temp. range of 0~50°C)	
	Storage temperature	Storage:-10-60°C (No condensation or freezing)	
	Ambient humidity	Operation/ storage:35-85%RH (No condensation)	
	Withstand voltage	1000V AC in 1-min (between case and lead wire)	
	Insulation resistance	50MΩ above (500V DC) (between case and lead wire)	
	Vibration	Total amplitude 1.5mm Or 10G,10Hz~150Hz~10Hz for 1 minute,two hours each direction of X,Y and Z	
	Shock	100m/s <sup>2</sup> (10G)3 times each in direction of X,Y and Z	
Port size		Rc1/8, M5	
Lead wire		φ4 oil-resistance PVC cable- 3 core	
Weight		67g(with 2-meter lead wire)	

# ZPDE Series

## High-precision Digital Pressure Switch

### Output circuit wiring diagrams

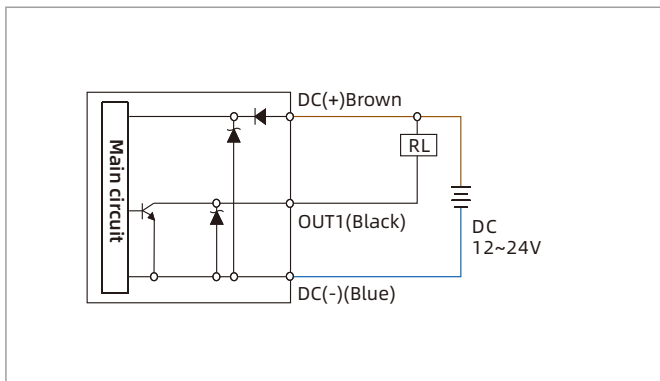

ZPDE-□N-R1M 1NPN output

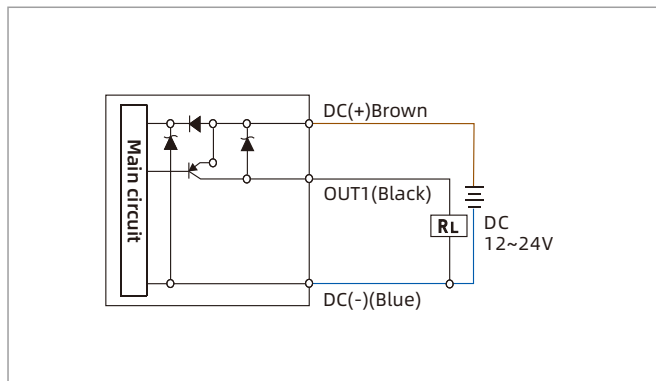

ZPDE-□P-R1M 1PNP output

### Panel instructions

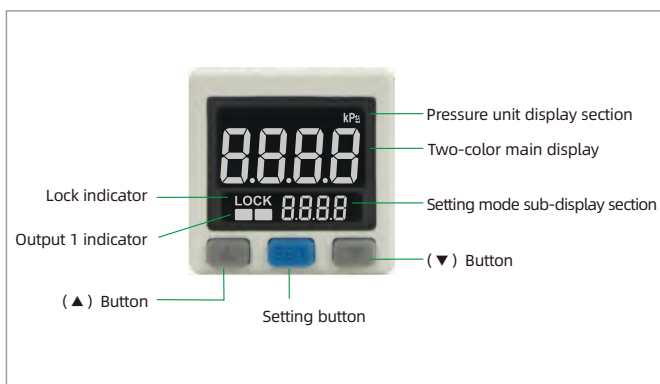

### Dimensions (mm)

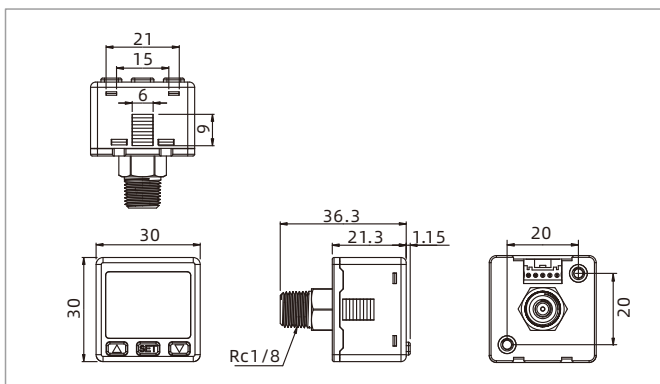

ZPDE-□N-R1M

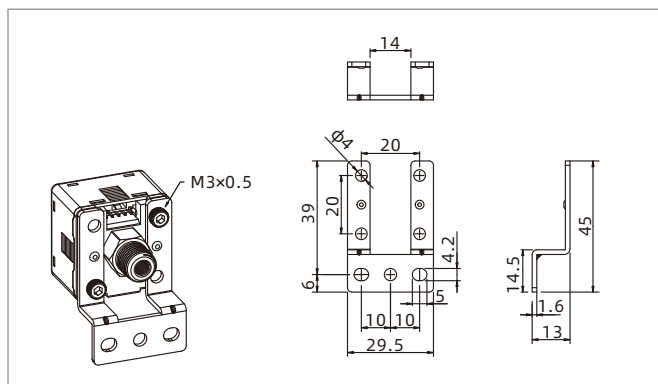

ZPDT-A-MB Mounting bracket A type

# ZPDE Series

## High-precision Digital Pressure Switch

### Dimensions (mm)

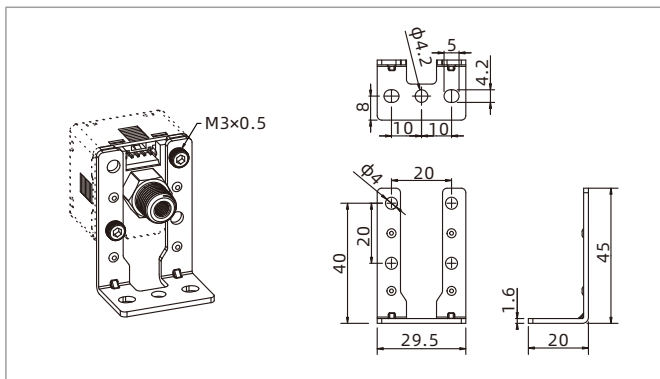

ZPDT-B-MB Mounting bracket B type

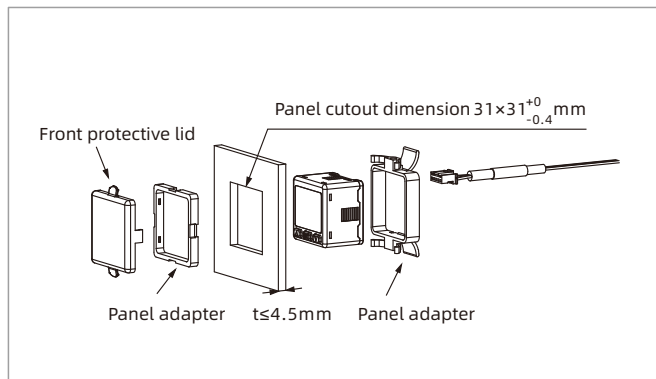

Panel type

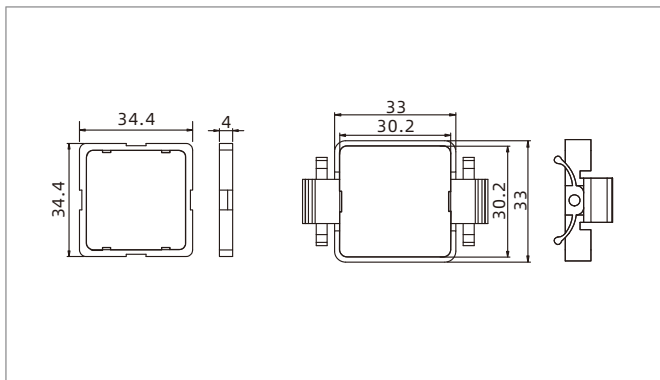

ZPDT-PS Panel adapter

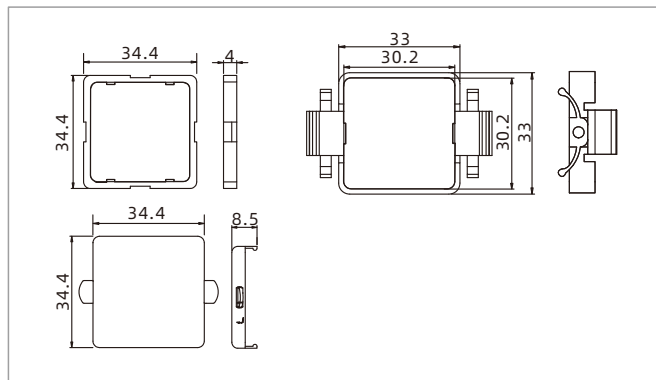

ZPDT-PC Front protective lid + panel adapter

### Accessories

Item	Model
Mounting bracket A type	ZPDT-A-MB
Mounting bracket B type	ZPDT-B-MB
Panel adapter	ZPDT-PS
Front protective lid + panel adapter	ZPDT-PC

# ZPMR Series

## Mechanical Pressure Gauge



UNIVERSAL



### Features

- ◇ Mechanical pressure gauge, panel is made of acrylic, and ABS black plastic for housing
- ◇ Back entry type mounting, universal specifications, easy to use



### How to order

## ZPMR - P <sup>①</sup> <sup>②</sup>

① Series	② Pressure type	Connection thread
ZPMR	P - Positive V - Negative	NPT1/8 male thread G1/8 male thread

### Technical parameters

Model	Pressure range	Dial size	Material of connector	Connection thread	Weight g
ZPMR-P	0~1MPa	1.5 inch	Copper alloy	NPT1/8	63.5
ZPMR-V	-100~0kPa	1.5 inch	Copper alloy	G1/8	57

### Dimensions (mm)

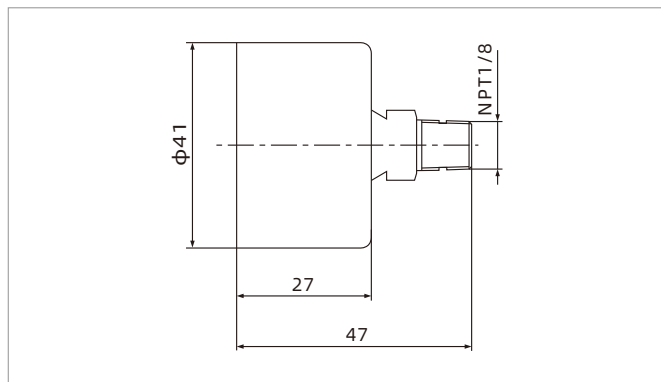

ZPMR-P

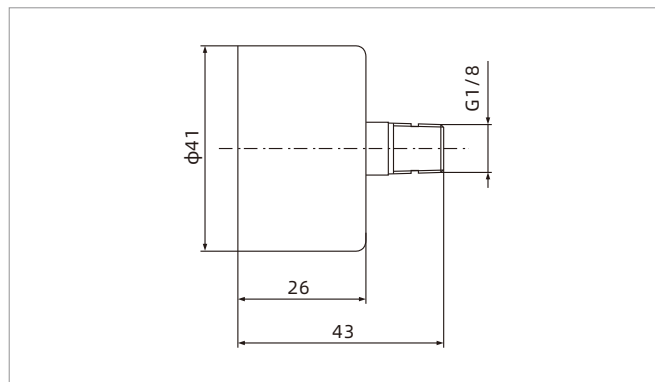

ZPMR-V

# ZSA Series

## Silencer



UNIVERSAL



### Features

- ◇ The silencers which are fitted to various standard vacuum generators can be ordered separately as replacements. They significantly reduce noise level on all exhaust applications



### How to order

## ZSA - G1M

①                      ②

① Series	② Connection thread
ZSA	G1M - G1/8 male thread G2M - G1/4 male thread G3M - G3/8 male thread G4M - G1/2 male thread G6M - G3/4 male thread G8M - G1" male thread

### Dimensions (mm)

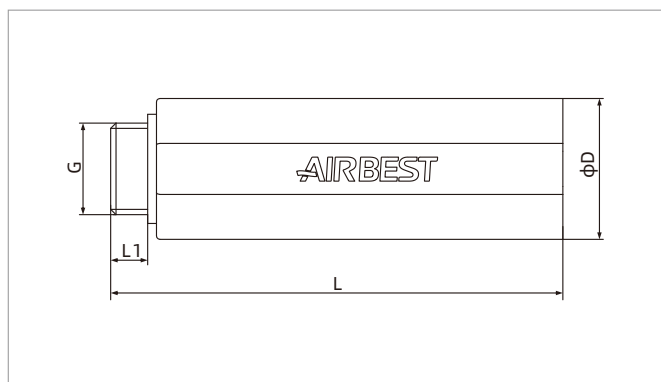

ZSA

Model/Size	L	D	G	L1	Weight g	Denoise dB(A)
ZSA-G1M	46	14	G1/8	5	3	10
ZSA-G2M	73	20	G1/4	8	20	10
ZSA-G3M	72	24	G3/8	8	25	10
ZSA-G4M	128	30	G1/2	7	35	10
ZSA-G6M	126	40	G3/4	7	55	10
ZSA-G8M	127.5	53	G1"	10	82	10



# AIRBEST

Make Smart



Go Together

# AIRBEST

**AIRBEST (CHANGXING) TECHNOLOGY CO.,LTD.**

Add: No.1098, Changxing Avenue, Changxing  
Economic Development Zone, Huzhou, Zhejiang,  
China 313100

Tel: 86-572-6388266  
Fax: 86-572-6532123  
E-mail: [info@airbest.com](mailto:info@airbest.com)  
[www.airbest.com](http://www.airbest.com)



AIRBEST Website



AIRBEST WeChat ID